

# Water Supply Engineering

Subject Code: 26455

5<sup>th</sup> Semester Civil Technology , 2022 Probidhan



Lutfor Rahman  
Jr Instructor (Tech/Environmental)  
Sherpur Polytechnic Institute, Sherpur  
01767213328

## Chapter No-01

# Understand the different sources of Water

1. Identify different sources of water
2. Explain the Hydrological cycle.
3. State the advantages and disadvantages of ground water.
4. Mention the advantages and disadvantages of surface water.
5. Distinguish between the ground water supply and surface water supply in respect to quality of water.
6. Explain rain water harvesting.

# The Case of Unsustainaville

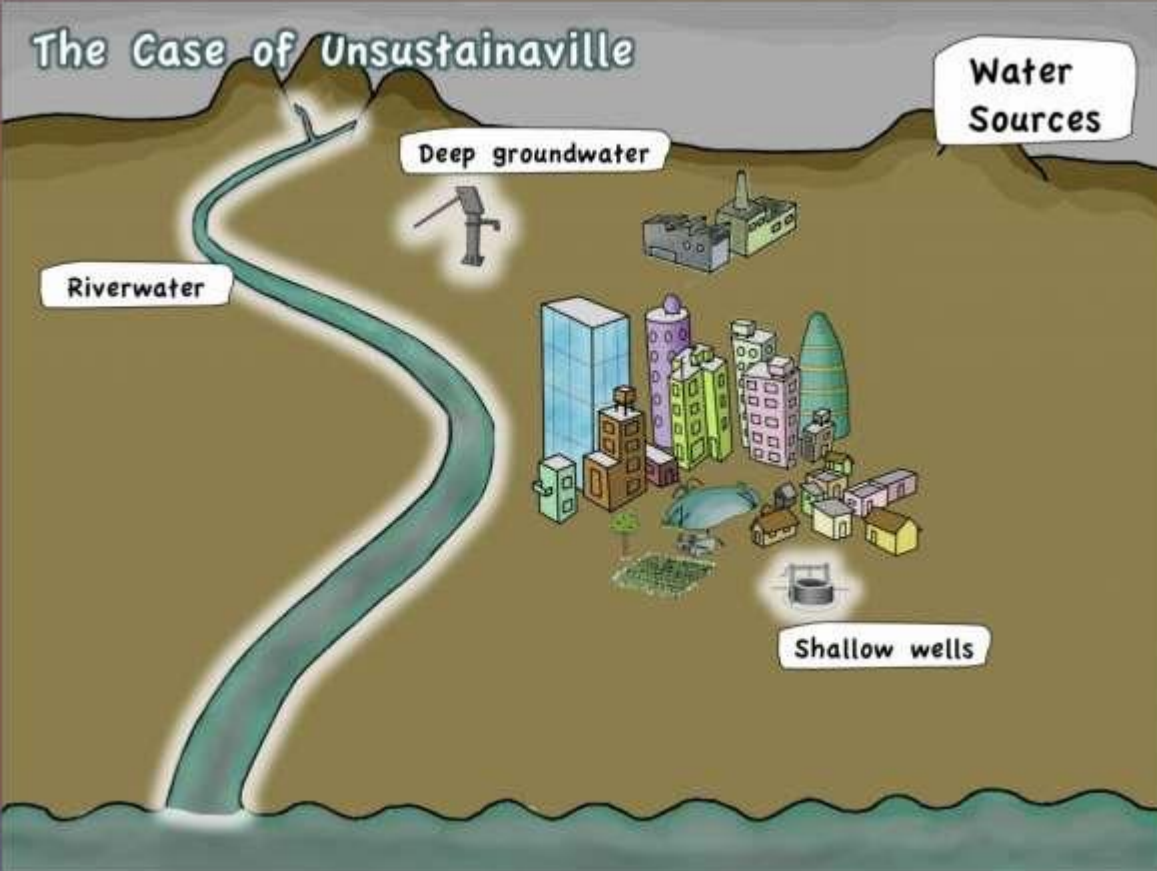

## MAIN SOURCES OF WATER

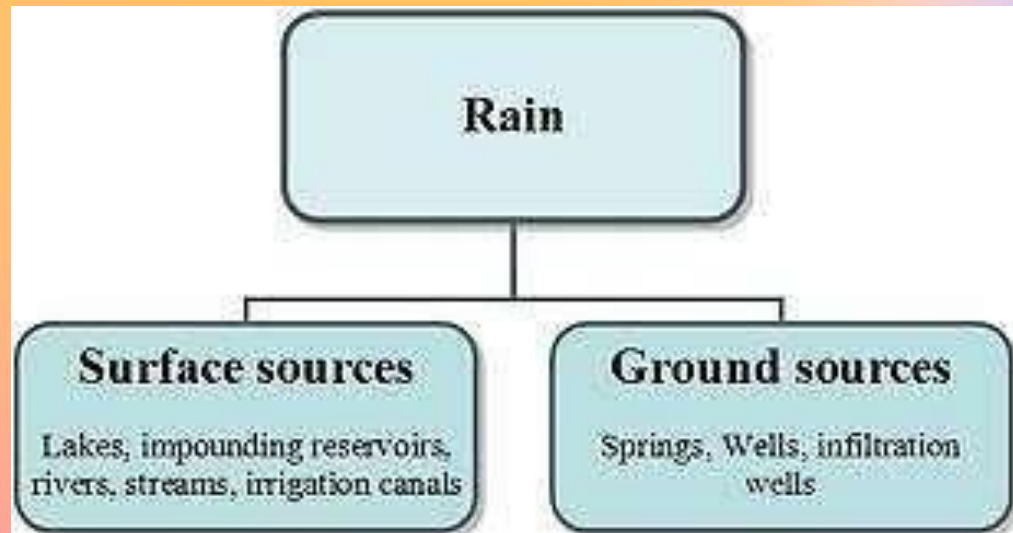

# NATURAL RESOURCES OF WATER



Naulas and Dharas

## PERCENTAGE OF WATER USED DAILY

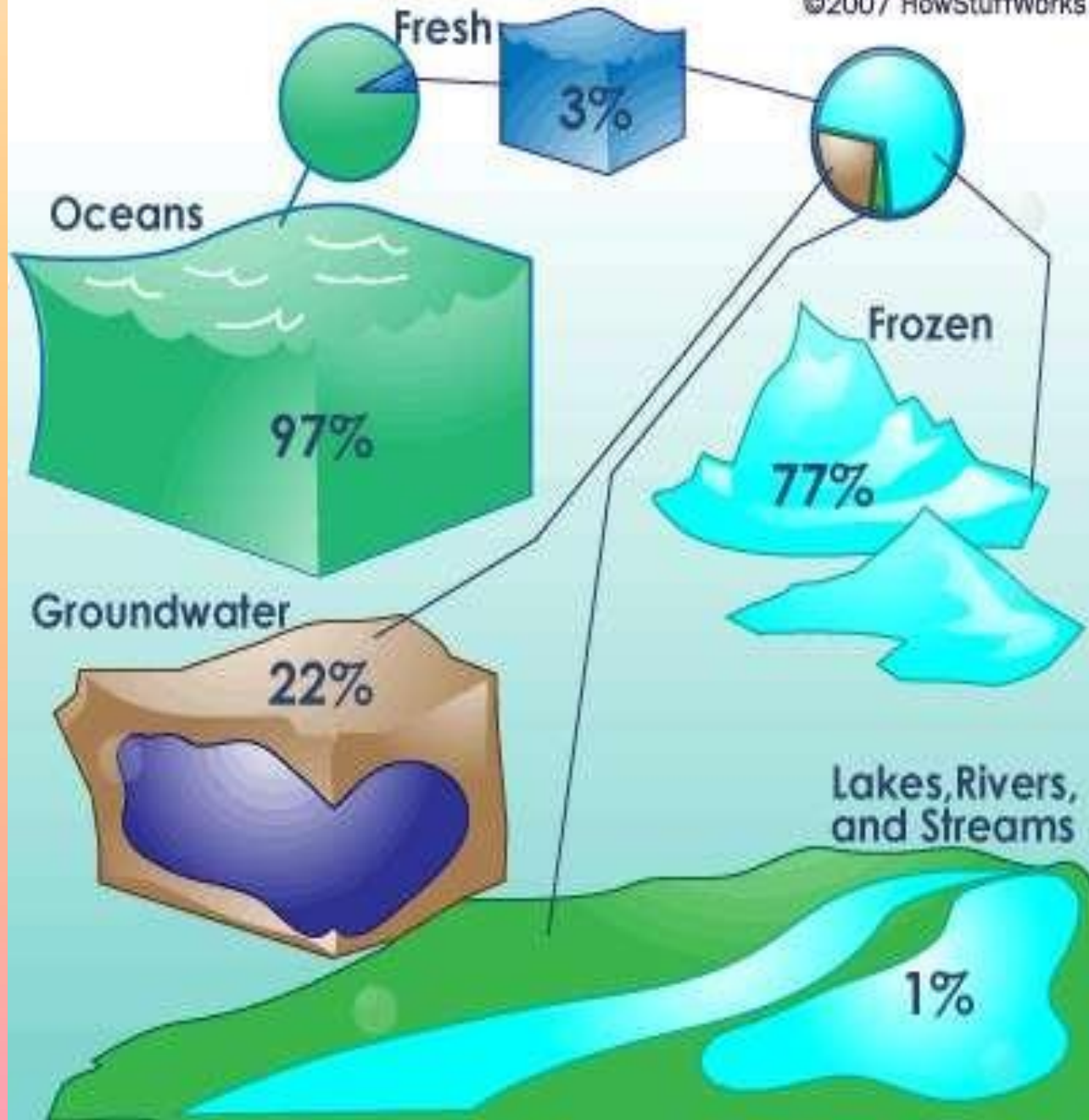

# Chapter No-02

Understand the various aspects of consumption of water

1.Explain the influence of the factor which affects per capita consumption of water:

a. Size of City

B . Characteristics of population

c. Industries and commercial organization

d. Climate Condition

e. Metering of water

# WATER DISTRIBUTION SYSTEM

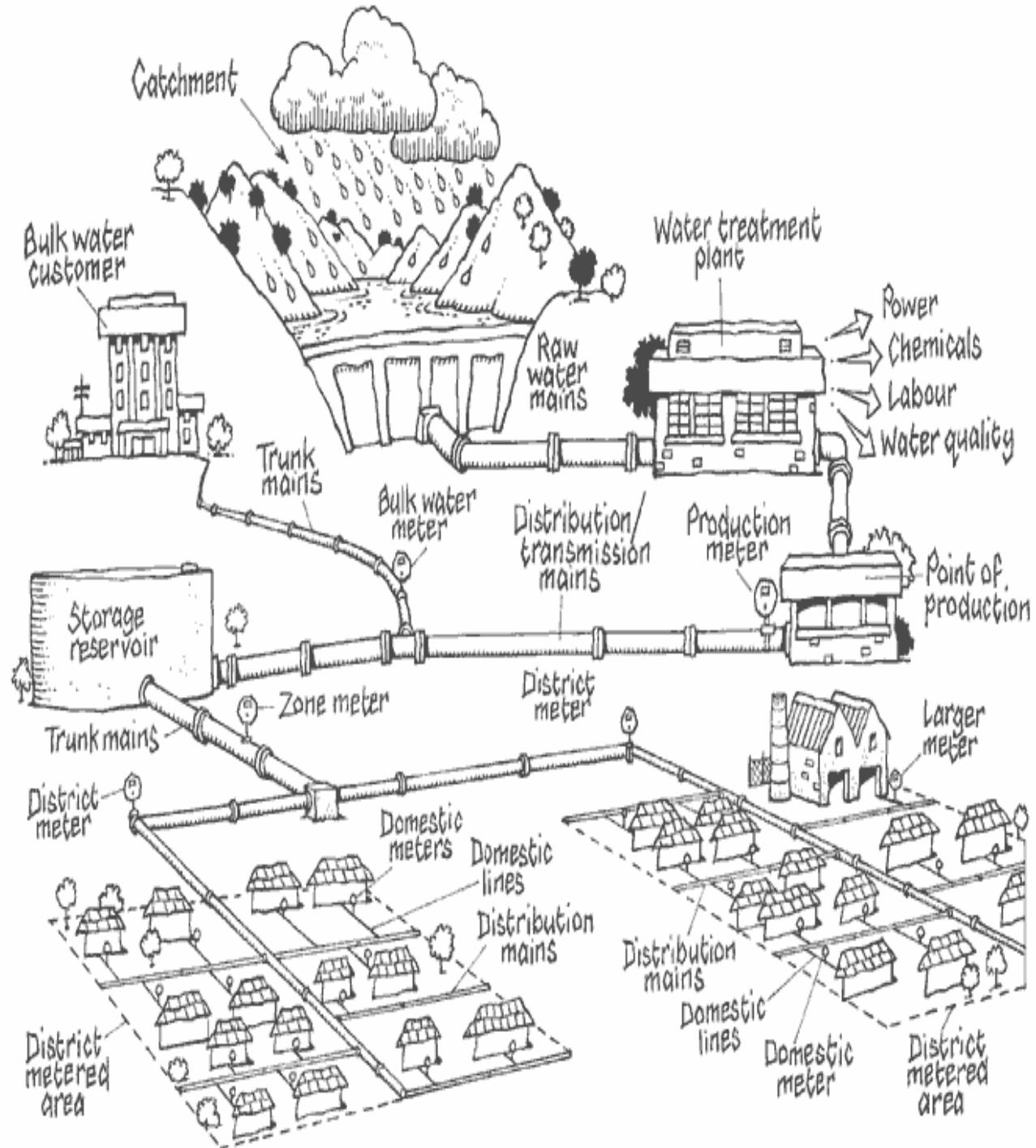

# Water distribution system

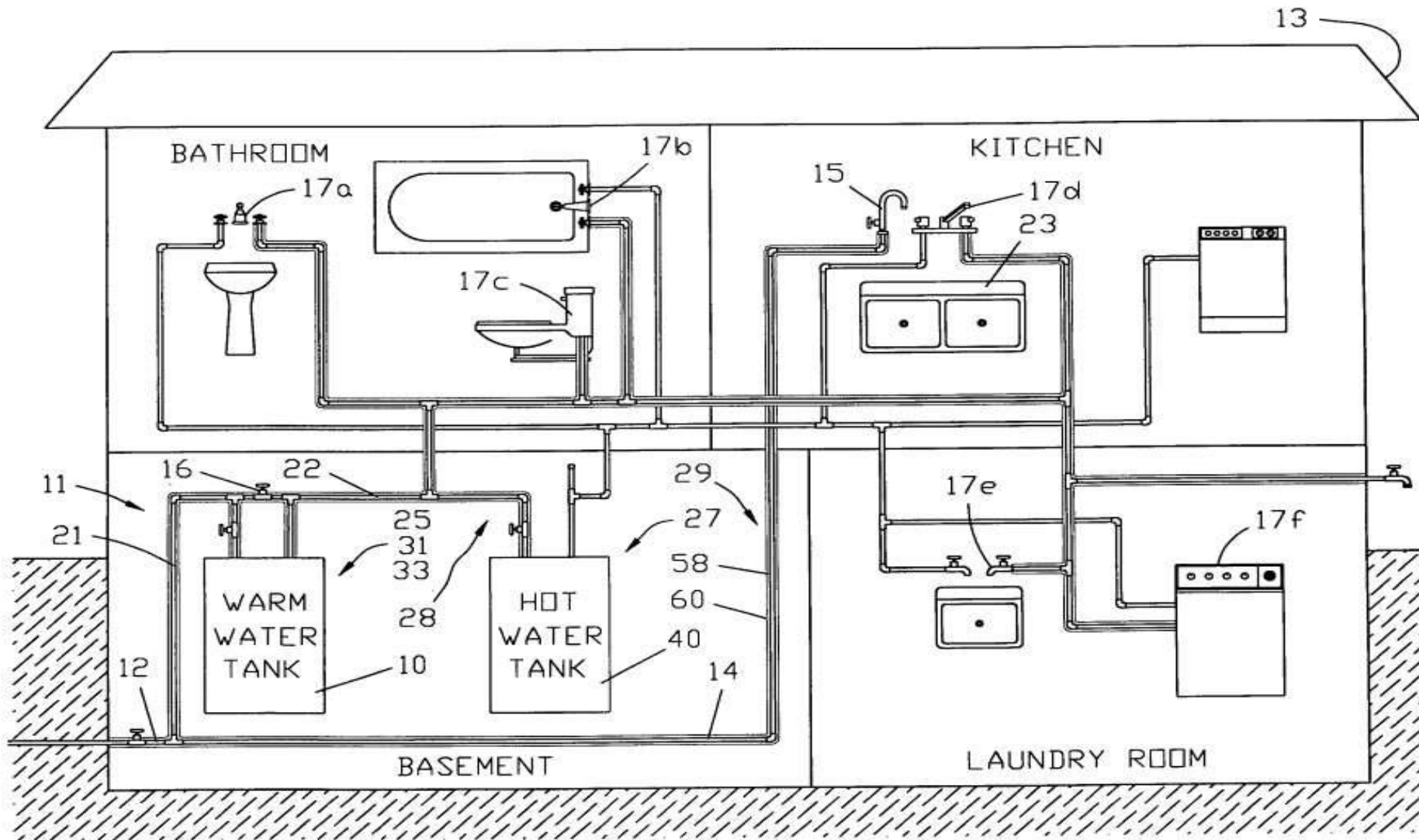

# WATER DISTRIBUTION SYSTEM

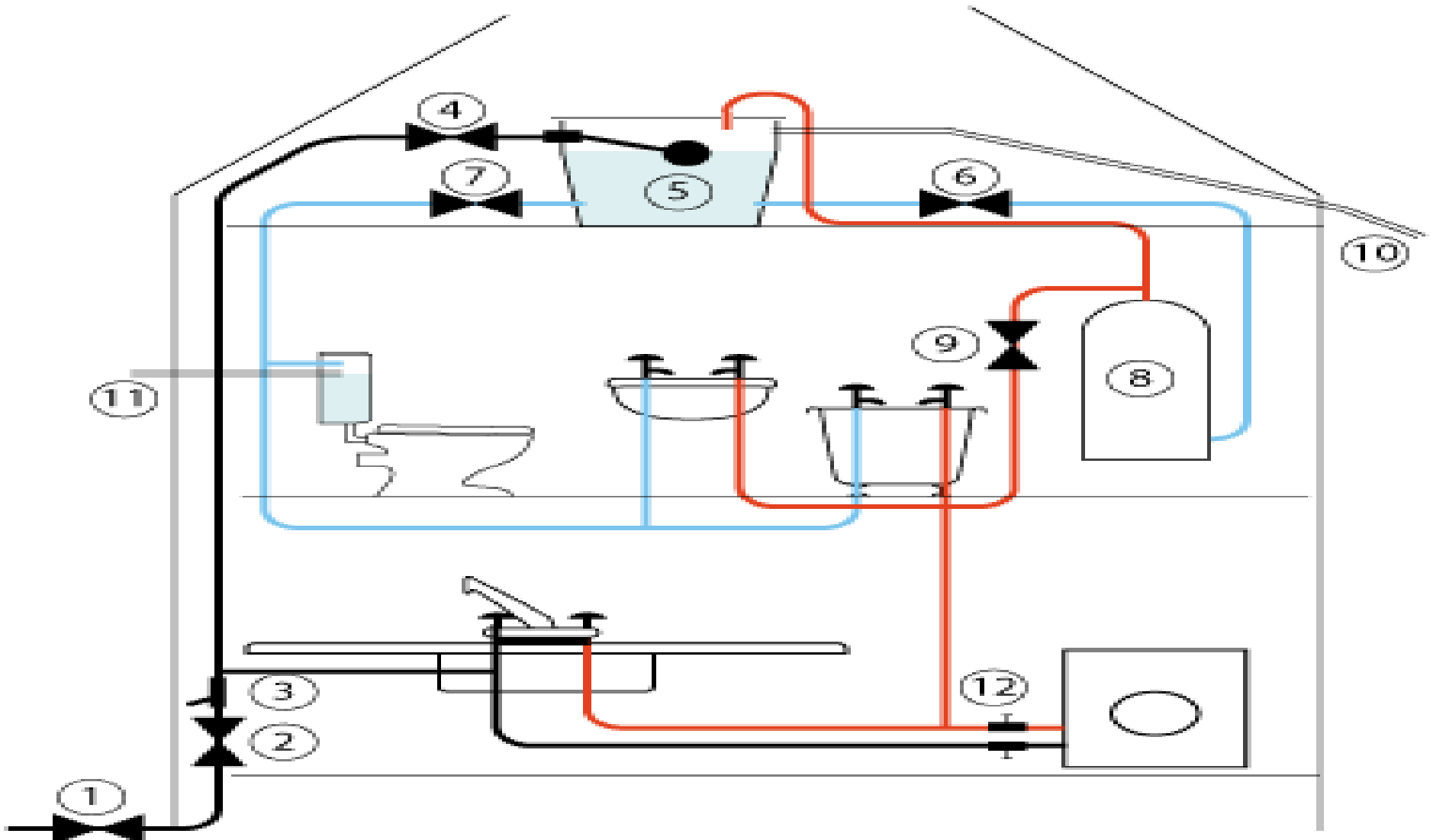

# INDIRECT WATER SUPPLY

Water going to overhead tank and then the water is supplied to different floors by gravity

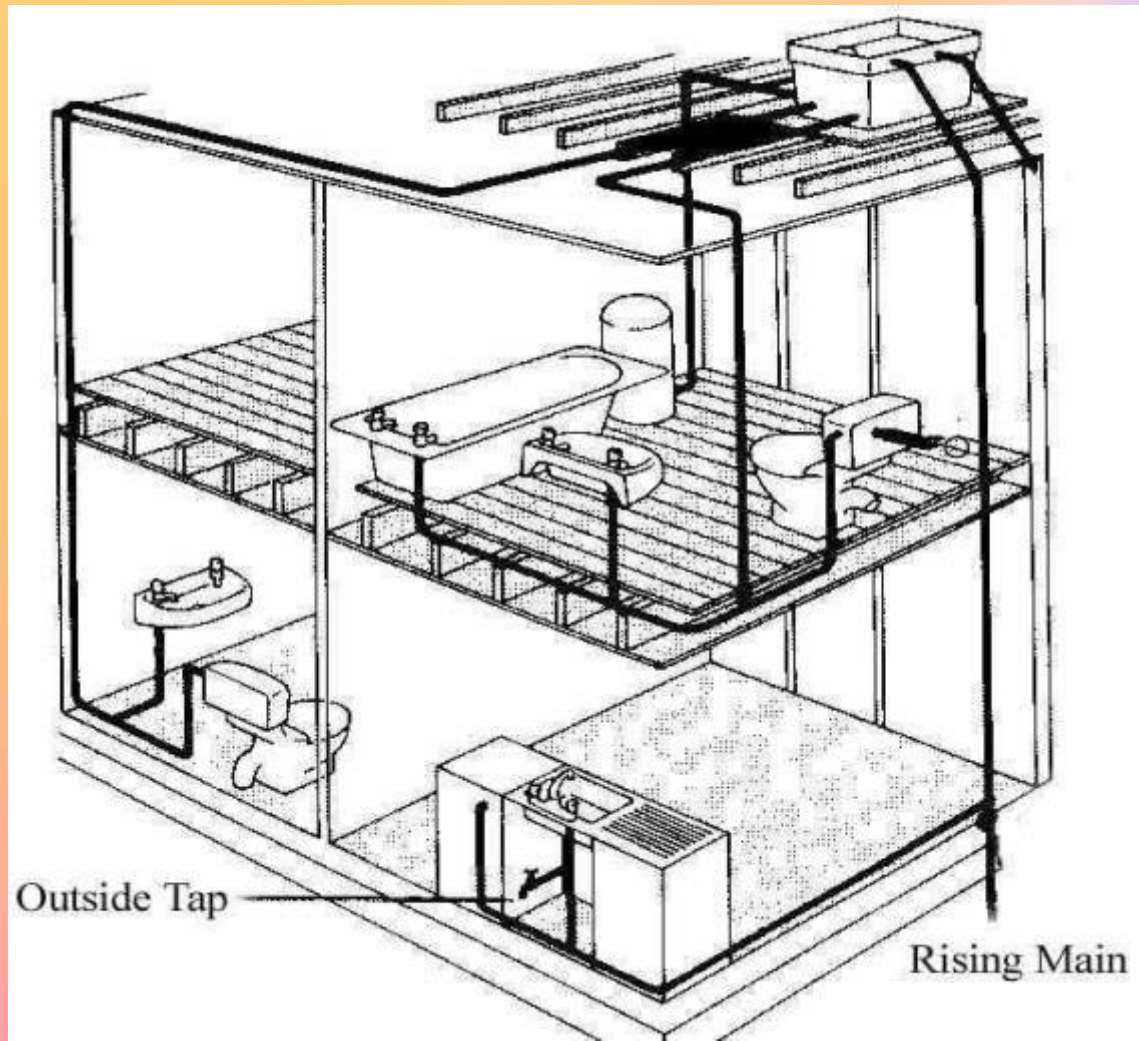

## Chapter no-03

Understand the different type of pipes & pipe joints used in water supply and the reasons for corrosion in metal pipes.

1. Classify the different type of pipes according to size ,materials ,quality and allowable stresses used in Bangladesh.
2. Explain the causes of corrosion of metal pipes.
3. Describe the methods of prevention and protection against corrosion.
4. Explain the causes of deterioration in non metal pipes.
5. Describe with sketches the different joints used in pipes.
6. Describe with sketches the fittings of pipes and valves used.

# HOLLOW PIPES



# GALVANISED IRON (G. I . PIPES)



# LEAD PIPES



# PVC PIPES



# JOINTS

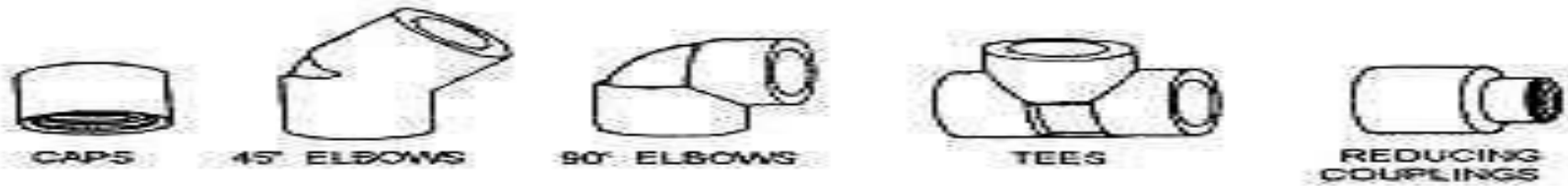

## PLASTIC PIPE FITTING

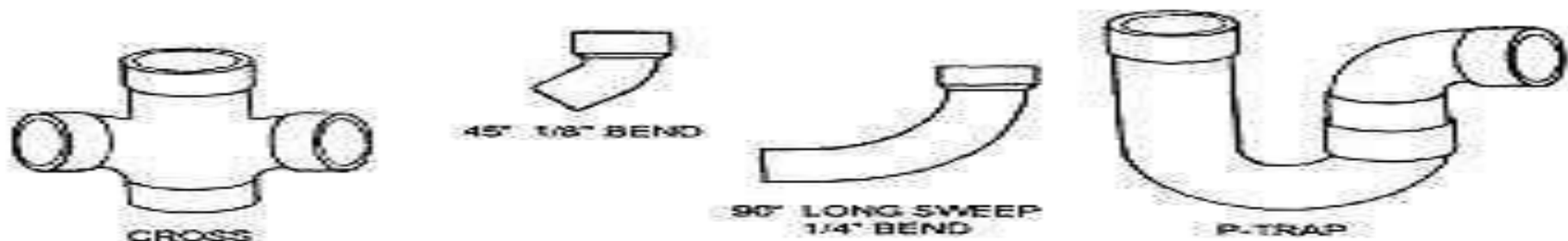
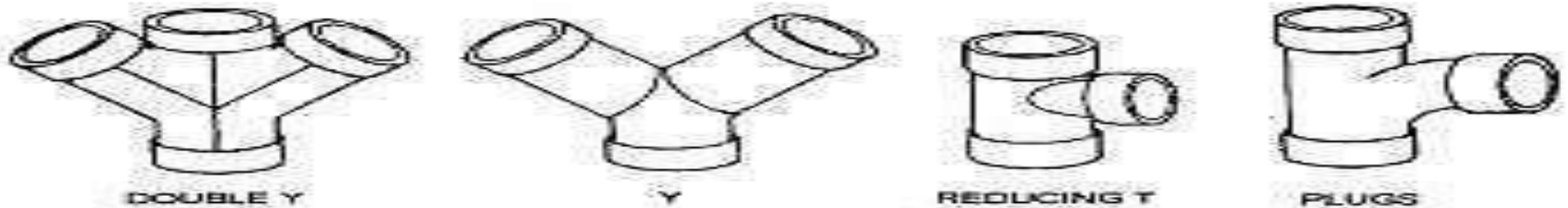

# JOINTS



Plain End Bend



Single Flange Bend



Double Flange Bend



Short Pipe



Plain End Tee



Off Take Tee



All Flange Tee



M. S Pipe



Plain End Taper



Single Flange Taper



Double Flange Taper



Welding Collar

# GATE VALVE

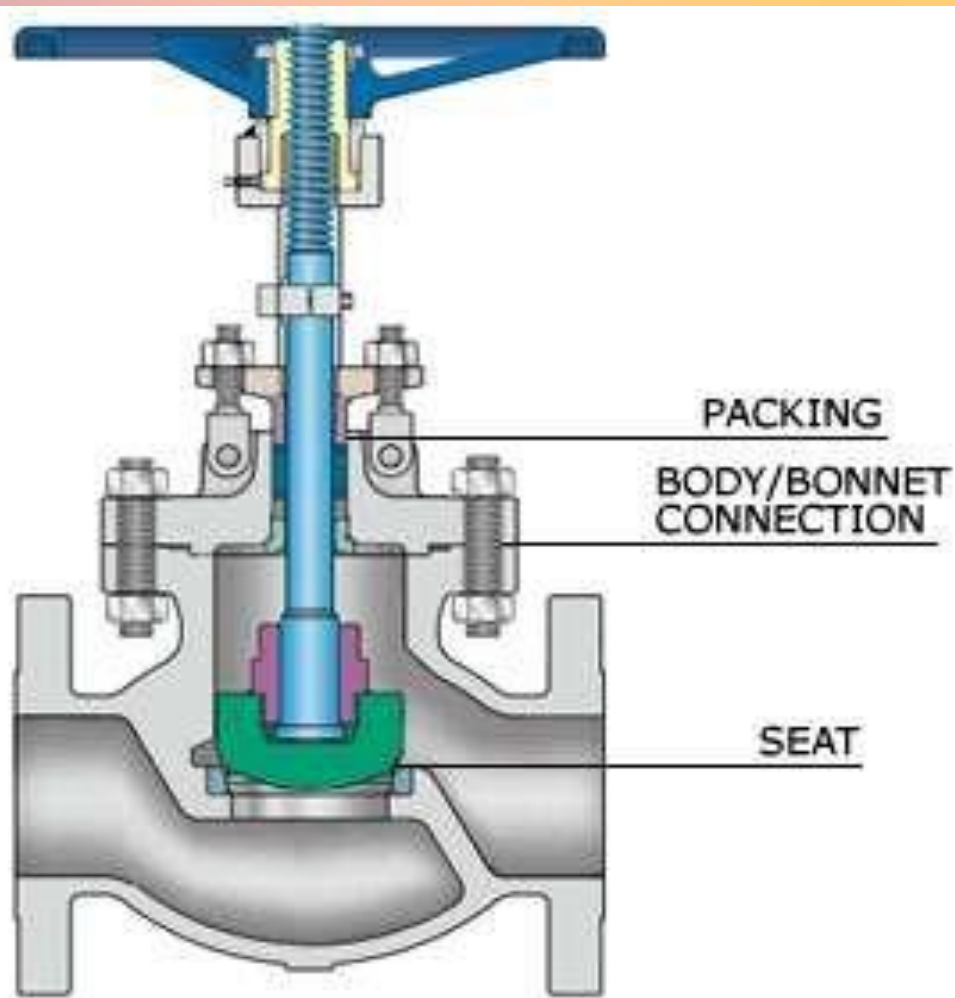

# GLOBE VALVE

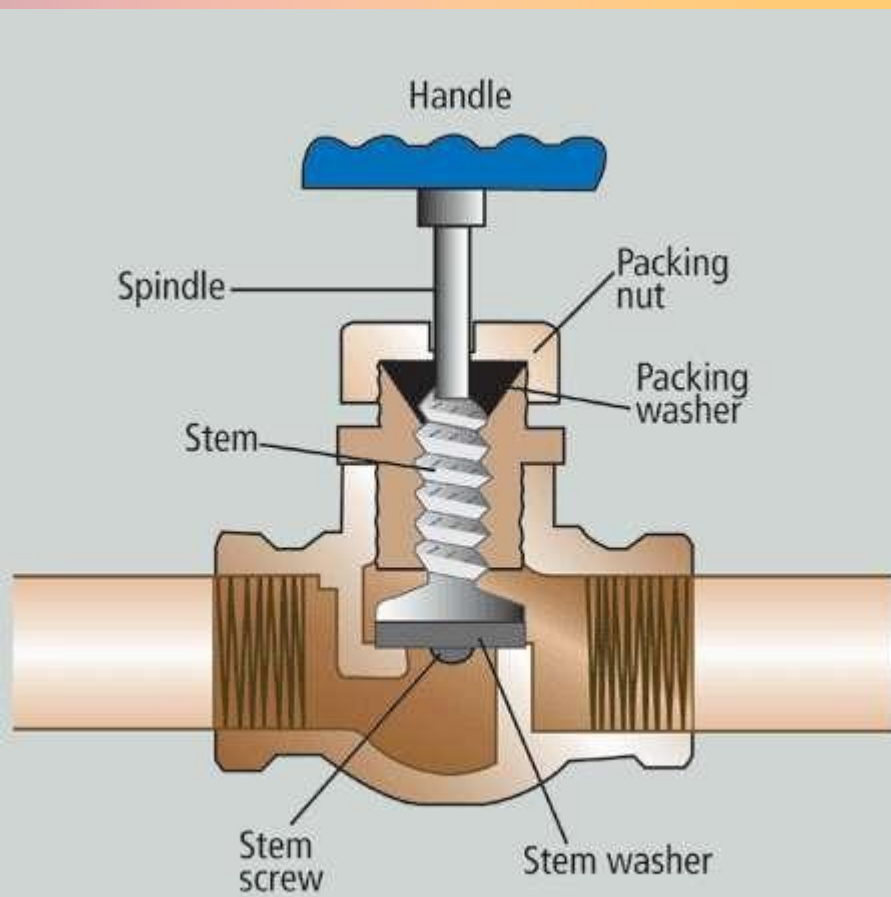

# RELIEF AND FLOAT VALVE

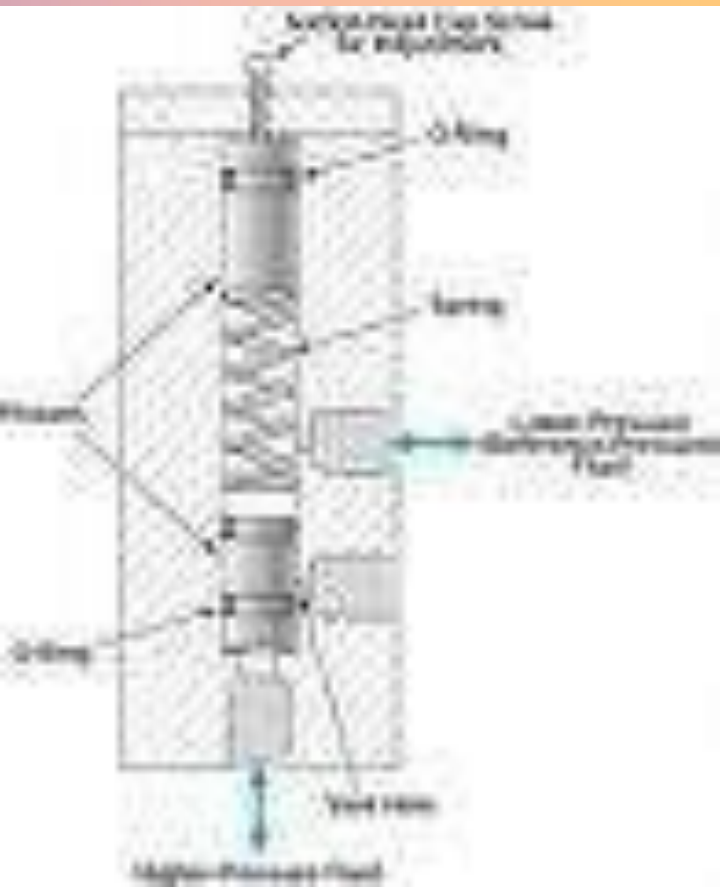

# TAP OR BIB COCK



# STOP COCK



# VARIOUS FITTINGS – GLOBE VALVE



# STOP TAP

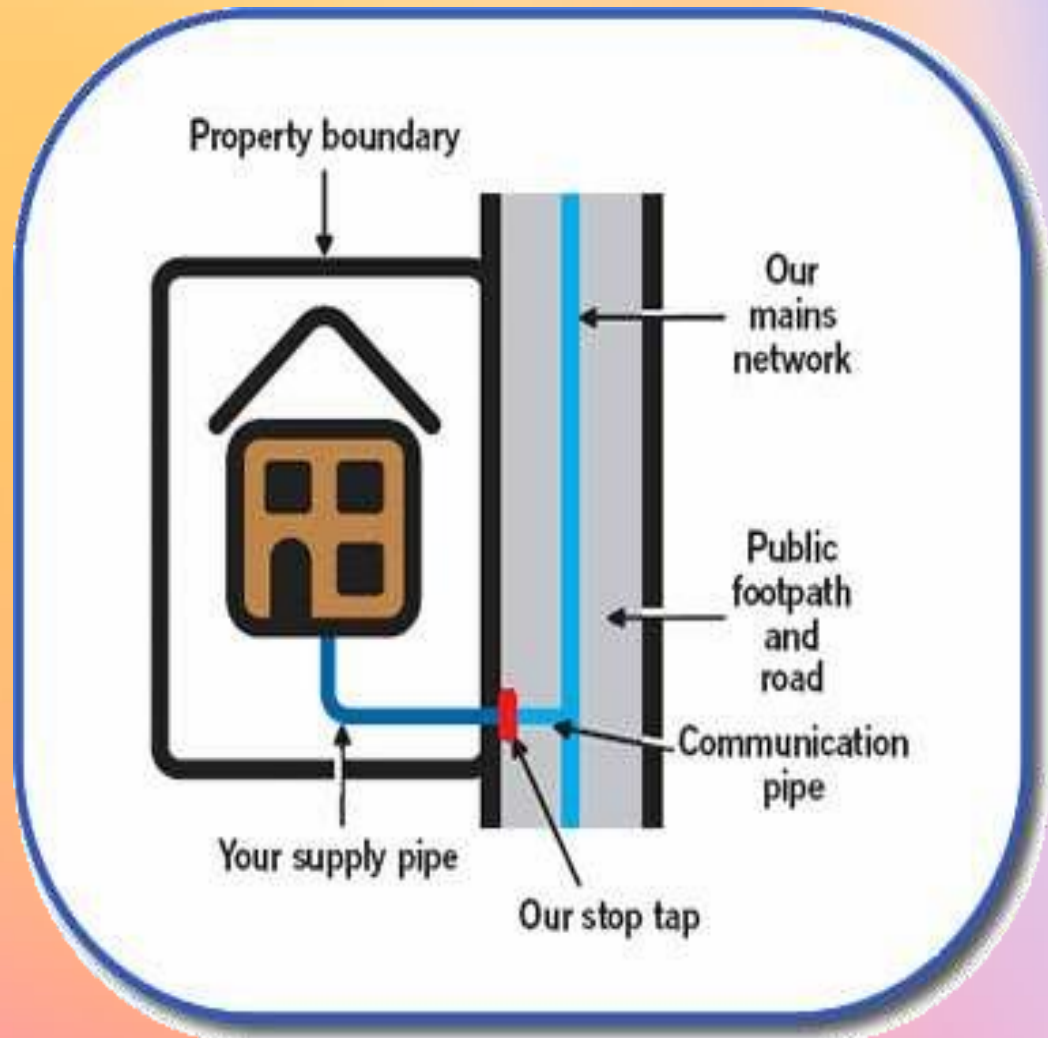

# VARIOUS VALVES , TUBES AND PIPES



Copper Pipe  
Clips 22mm



Copper Tube  
15mm x 20m



Micro bore  
Copper Tube  
10mm x 25m



Pegler Ball Valve  
Red 15mm



Pegler Double  
Check Valve  
15mm



Pegler Gate  
Valve 22mm



Pegler Washing  
Machine Tap  
15mm x  $\frac{3}{4}$ "



PTFETape 12m  
Pk of 10

## Chapter no-04

### Understand the importance of Plumbing System

1. Define Plumbing System
2. List the requirements of plumbing installation
3. Identify with sketches the various Plumbing Fittings and Fixtures.
4. Describe the uses of various plumbing fittings and fixtures.
5. List the tools required for plumbing works.
6. Mention the uses and maintenance of various plumbing tools

# SANITARY





# TYPES OF FITTINGS

# SANITARY SYSTEM



# INTRODUCTION

**It is the arrangement provided in a house or building for collecting or conveying waste water through drain pipes, by gravity, to join either a public sewer or a domestic septic tank is termed as house drainage or building drainage.**

# SANITARY SYSTEM

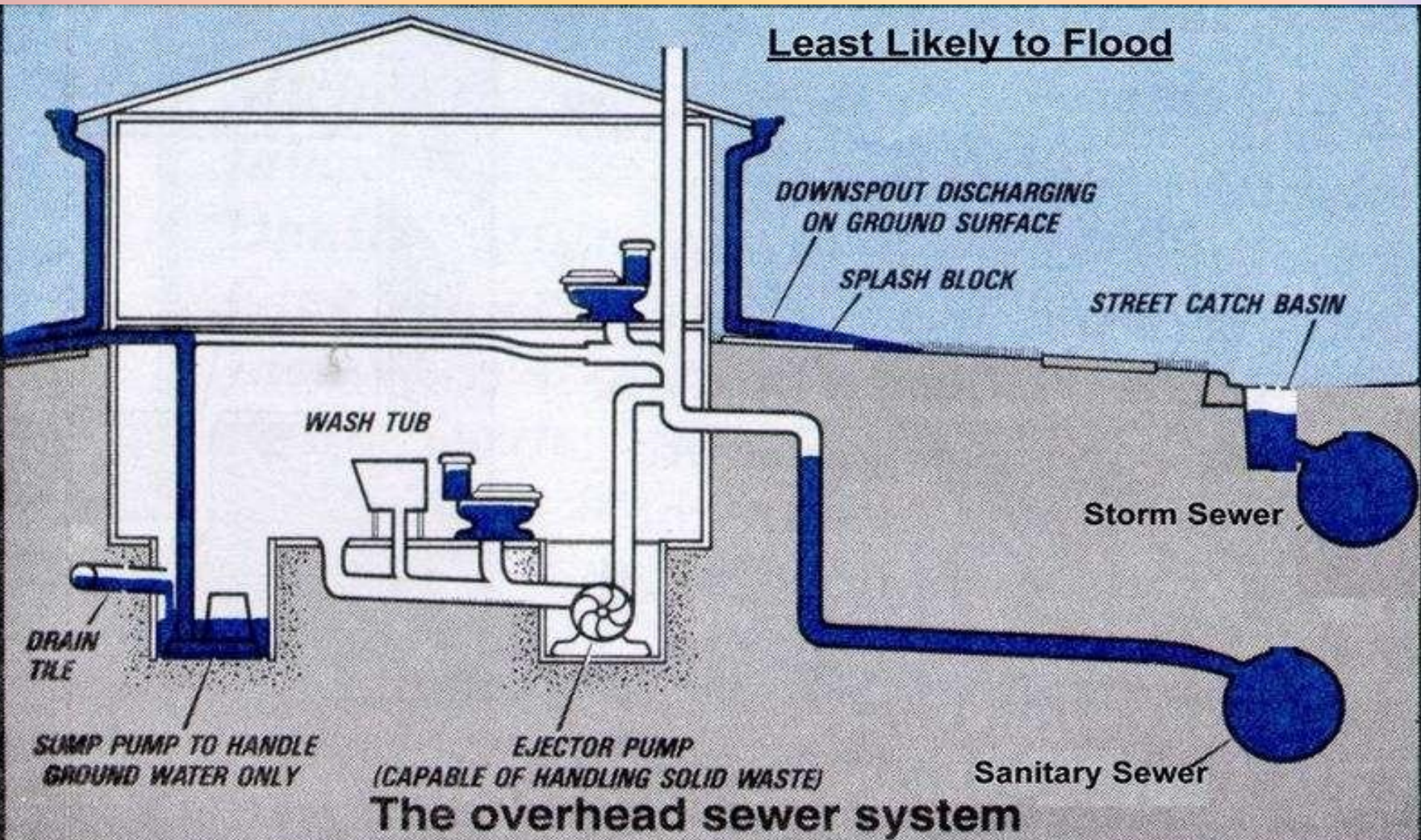

# AIMS OF HOUSE DRAINAGE

- To maintain healthy conditions in the building
- To dispose off waste water as early and quickly as possible
- To avoid the entry of foul gases from the sewer or the septic tank
- To facilitate quick removal of foul matter
- To collect and remove waste matters systematically

# SANITARY SYSTEM

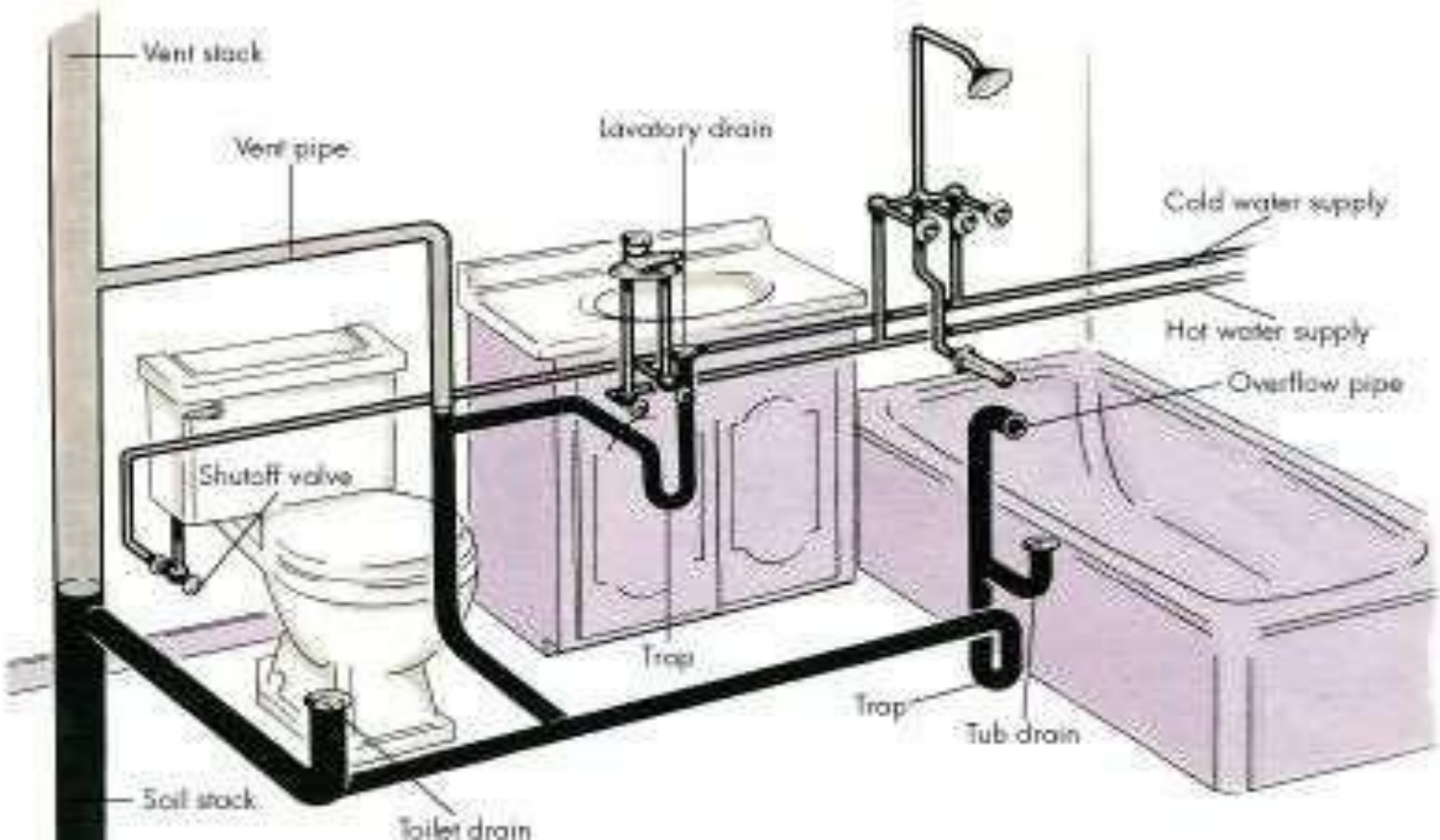



# PIPES

<b>Material</b>	<b>Application</b>	<b>Jointing</b>
Cast iron	50 mm and above vent and discharge stacks	Lead caulking with molten or fibrous lead; cold compound caulking
Galvanised steel	Waste pipe	Screwed
Copper	Waste pipes and traps	Compression, capillary, silver solder, bronze weld or push-fit rings seal
Lead	Waste pipes and discharge stacks	Soldered or lead welded
ABS (acrylonitrile butadiene styrene)	Up to 50 mm waste and vent pipes	Solvent cement and push-fit ring seal
High-density polyethylene	Up to 50 mm waste and ventilating pipes and traps	Push-fit ring seal and compression fittings
Polypropylene	Up to 50 mm waste and ventilating pipes and traps	Push-fit ring seal and compression couplings
Modified PVC	Up to 50 mm waste and vent pipes	Solvent cement and push-fit ring seal
Unplasticized PVC	Over 50 mm soil and vent stacks; vent pipes under 50 mm	Solvent cement and push-fit ring seal
Pitch fibre	Over 50 mm discharge and vent stacks	Driven taper or polypropylene fitting with a push-fit ring seal

# PIPES

**Soil pipe:** A soil pipe is a pipe Through which human excreta flows.

**Water Pipe:** it is a pipe which carries only the liquid waste. It does not carry human excreta.

**Vent pipe;** it is a pipe which is provided for the purpose of the ventilation of the system. A vent is open at top and bottom, to facilitate exit of foul gases. It is carried at least one meter higher than the roof level.

**Rain water pipe:** it is a pipe which carries only the rain water.

**Anti-siphonage pipe:** it is pipe which is installed in the house drainage to preserve the water seal of traps.



# SIZES OF PIPES

- Soil pipe:
- Waste pipe:
  - horizontal: 100mm
- Waste pipe: vertical : 30-50mm
- Rainwater pipe : 75mm
- Vent pipe: 75mm
- Anti siphonage pipe: 50mm
- Connecting soil pipe: 50m
- Connecting waste pipe: 40m



# TYPES OF TRAPS ACCORDING TO SHAPE:

- 'P' TRAP
- 'Q' TRAP
- 'S' TRAP ACCORDING TO USE:
  - FLOOR TRAP
  - GULLY TRAP
  - INTERCEPTING TRAPS
  - GREASE TRAPS

# TRAPS ACCORDING TO SHAPE

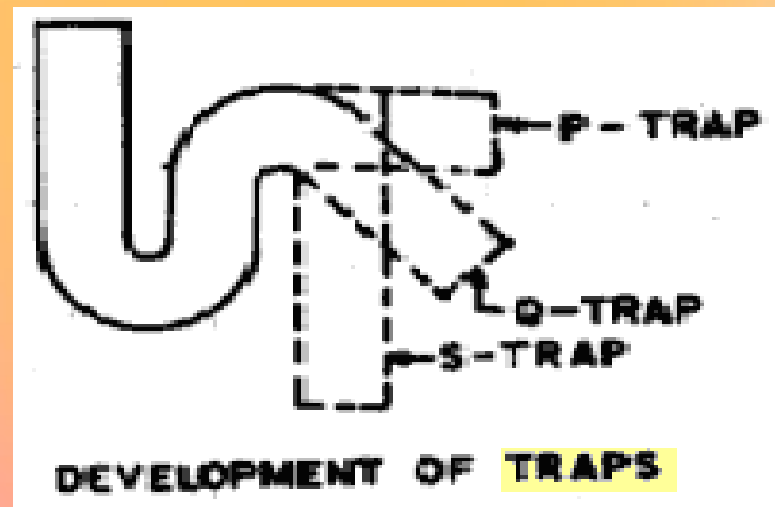
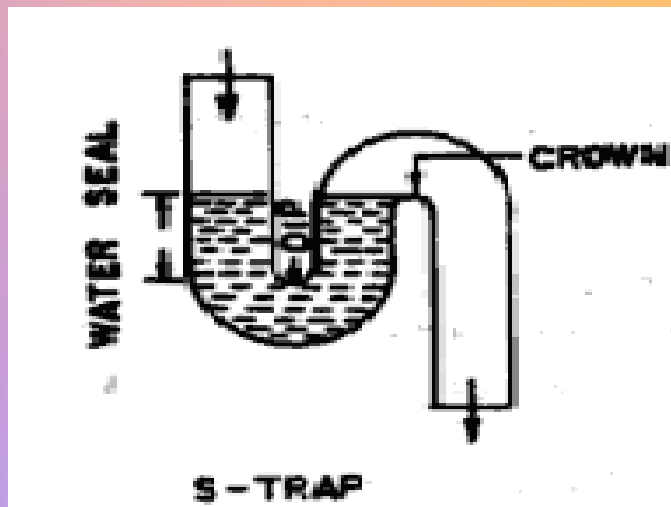
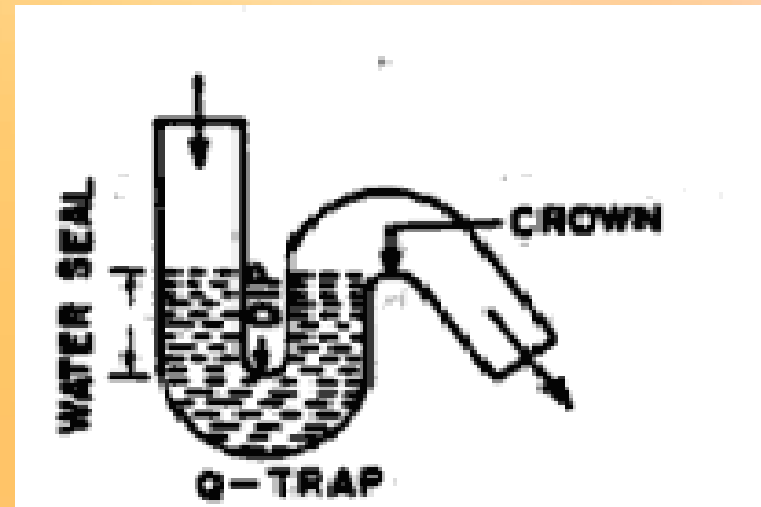
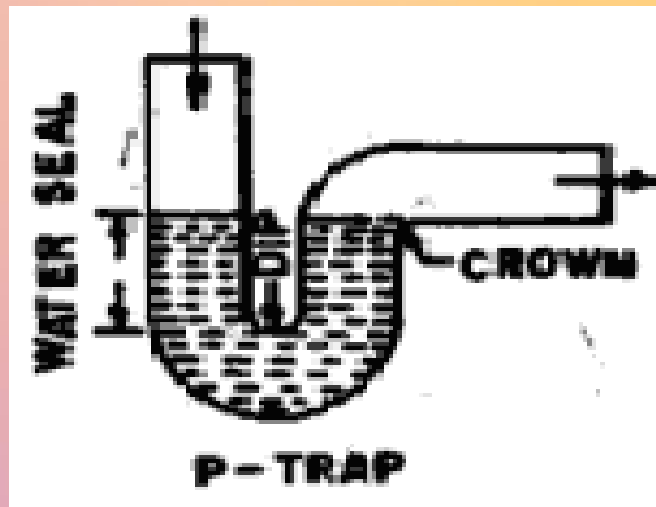

# TRAPS

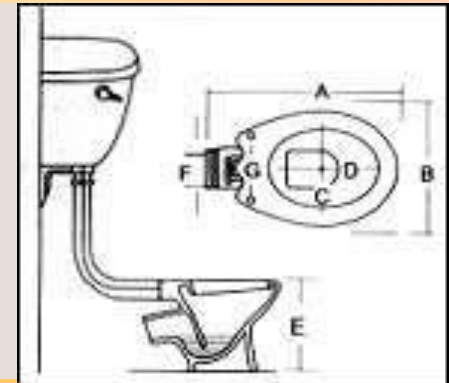
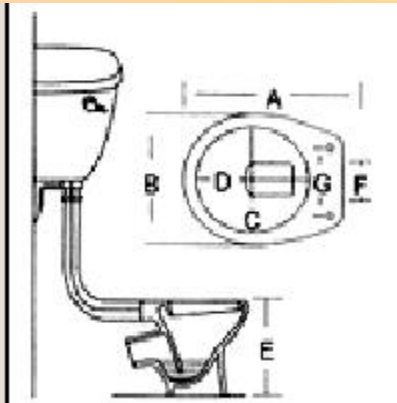

'P' TRAP

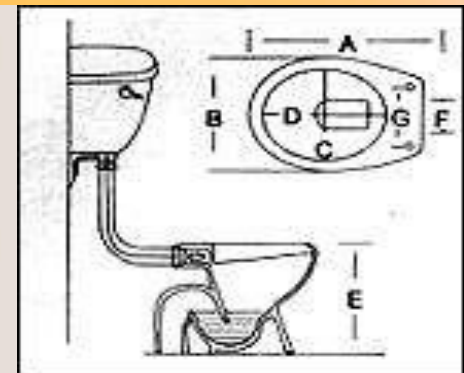
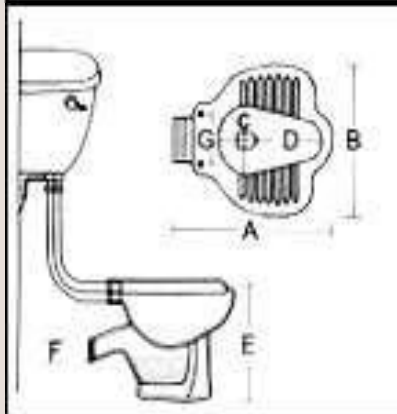

'S' TRAP

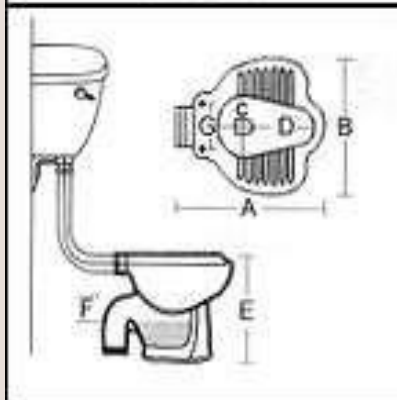

# SANITARY FITTINGS

- WASH BASINS
- SINKS
- BATH TUBS
- WATER CLOSETS
- URINALS
- FLUSHING CISTERNS

# BATH TUBS



# WASH BASINS



bestcraft.en.alibaba.com

MODEL:YG-227  
100x50x45cm



# WASH BASINS

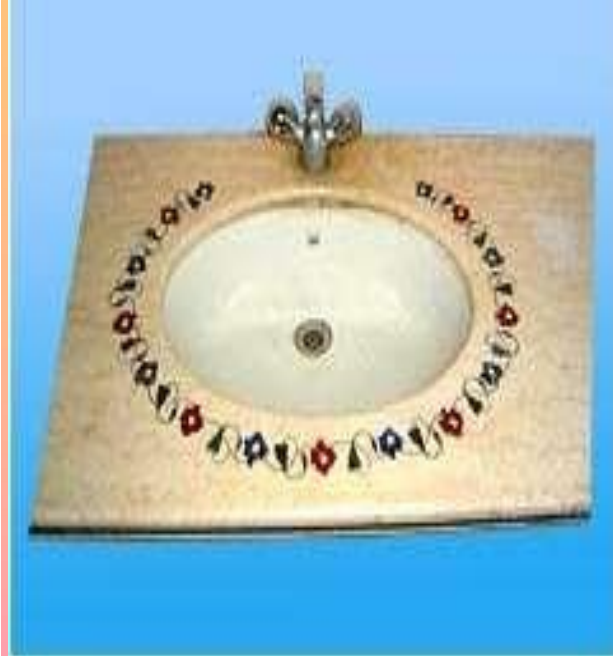

# SINK



# URINALS



GENTS TOILETS

STREET URINALS



LADIES TOILETS



PUBLIC TOILETS

# WATER CLOSETS & CISTERNS



EUROPEAN

# WATER CLOSETS



INDIAN



ANGLO-INDIAN

## Chapter No-05

Understand the water supply system with specific reference to Rural & City in Bangladesh

1. Give instruction to alternative technologies in problem areas of Bangladesh :

Shallow shrouded Tube well ,very Shallow shrouded Tube Well,Pond sand filter,Infiltration galleries,Iron Removal unit and deep set technologies.

PLUMBING SYSTEMS

SINGLE STACK SYSTEM

FULLY VENTILATED STACK SYSTEM

ONE PIPE SYSTEM

DUAL PIPE SYSTEM

MODIFIED SINGLE PIPE SYSTEM

## ONE PIPE SYSTEM

In the system all soil and waste water discharge into one common pipe and all branch ventilating pipes into one main ventilating pipe. This system largely replaces the two pipe system and lent itself very well to use in multi storey developments. It is far more economical than the two pipe system.

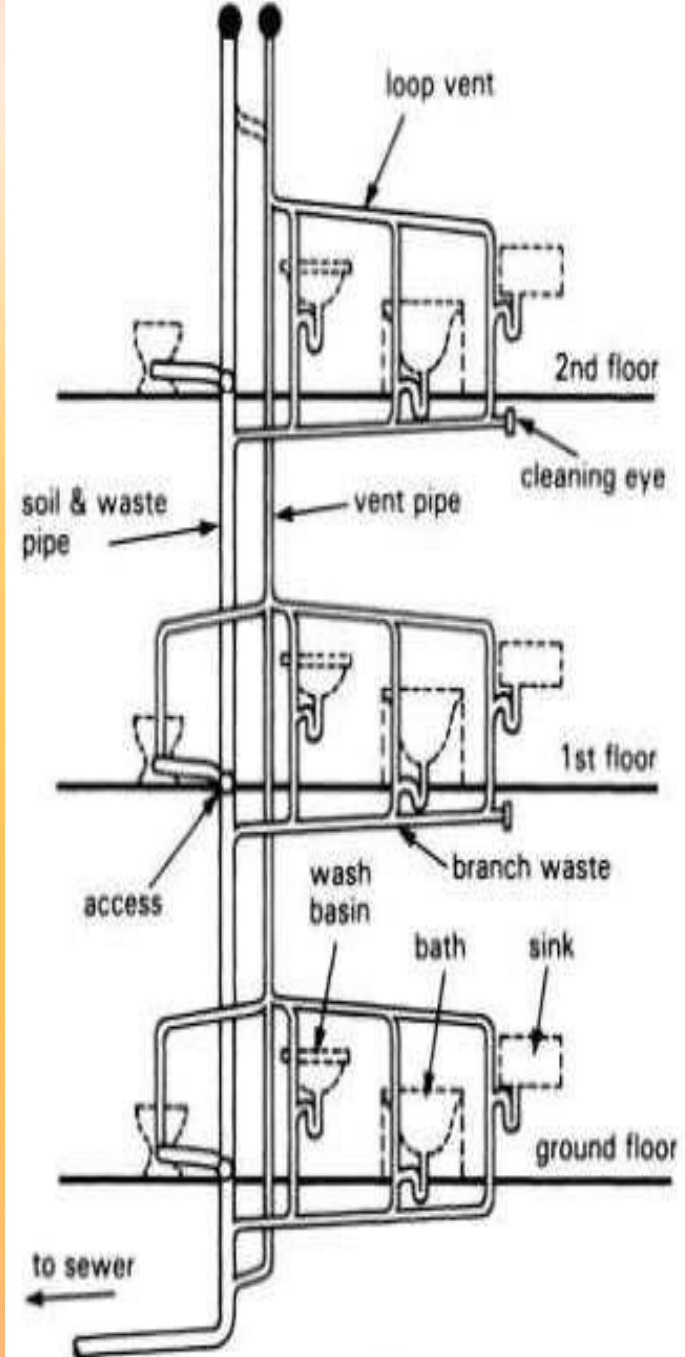

*The one-pipe system*

## TWO PIPE SYSTEM

The waste stack received the discharge ablutionary fittings and conveyed this to the ground level where it was delivered above the water seal in a trapped gully connected to the drainage system. the soil stack receives the discharge from soil appliances and delivered it direct to the underground drainage system. The waste and soil water did not combine until they reached the below ground drainage system.

the soil stack receives the discharge from soil appliances and delivered it direct to the underground drainage system. The waste and soil water did not combine until they reached the below ground drainage system.

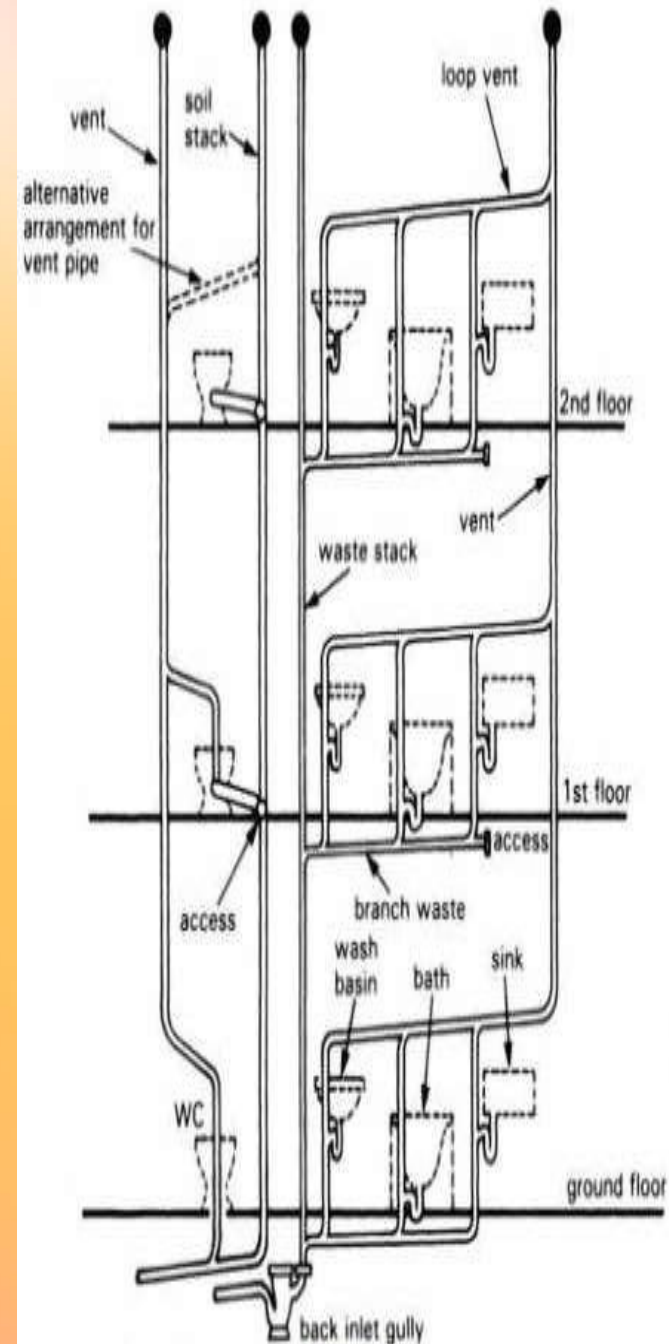

Two-pipe or dual-pipe system

## THE FULLY VENTILATED ONE-PIPE SYSTEM

A large number of sanitary appliances in ranges.

Each trap with an anti-siphon or vent pipe connected to the discharge pipe in direction of the flow of water at a point between 75 - 450 mm from trap crown.

Vent stack connected to the discharge stack near to the bend to remove compressed air at this point

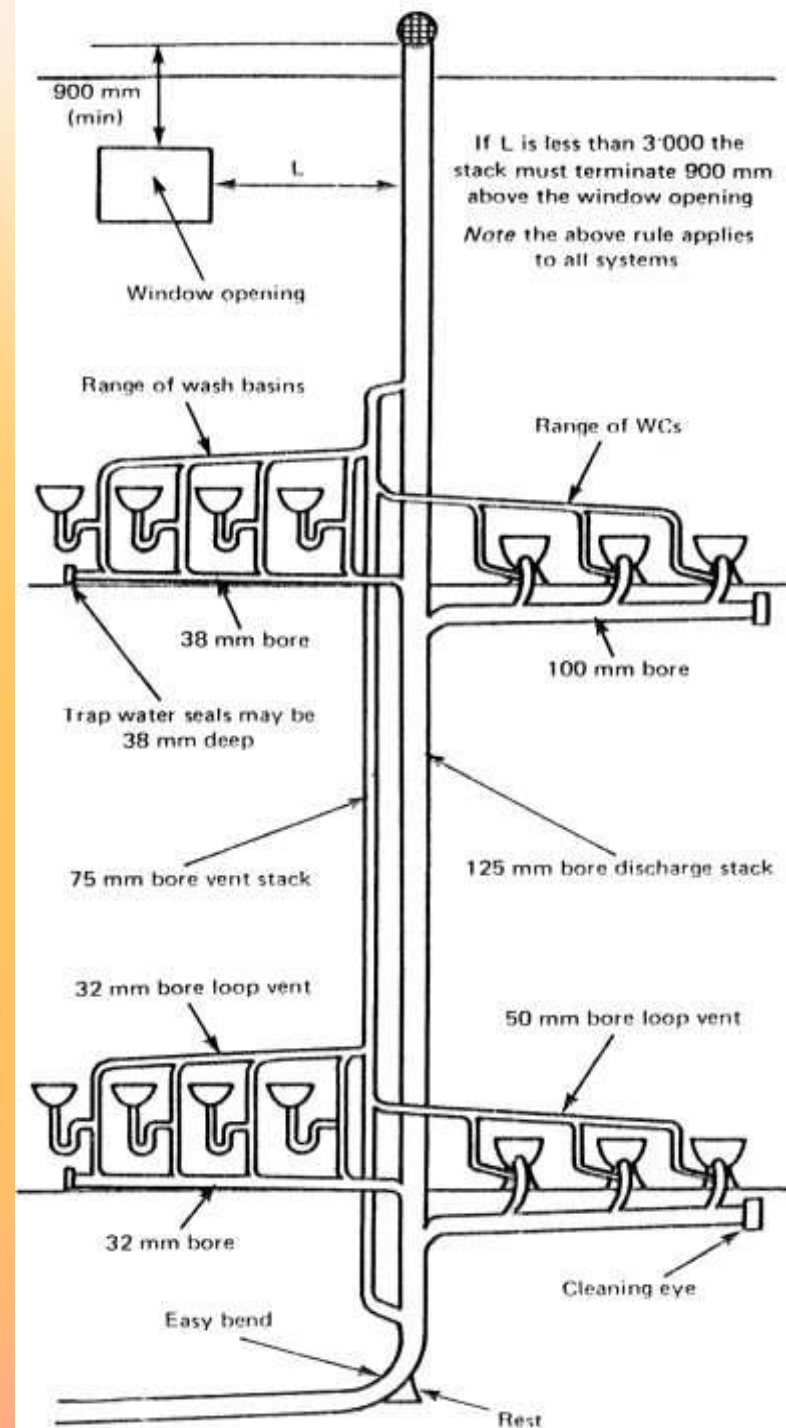

The single stack system Reduces the cost of soil and waste systems.

Branch vent pipes are not required

To prevent loss of trap water seals:-

The trap water seals on the waste traps must be 76 mm deep.

The slopes of the branch pipes are: sink and bath, 18 to 19 mm/m; basin 20-120 mm/m; WC 18 mm/m (min.).

Vertical stack at 200 mm below the centre of the WC branch connection.

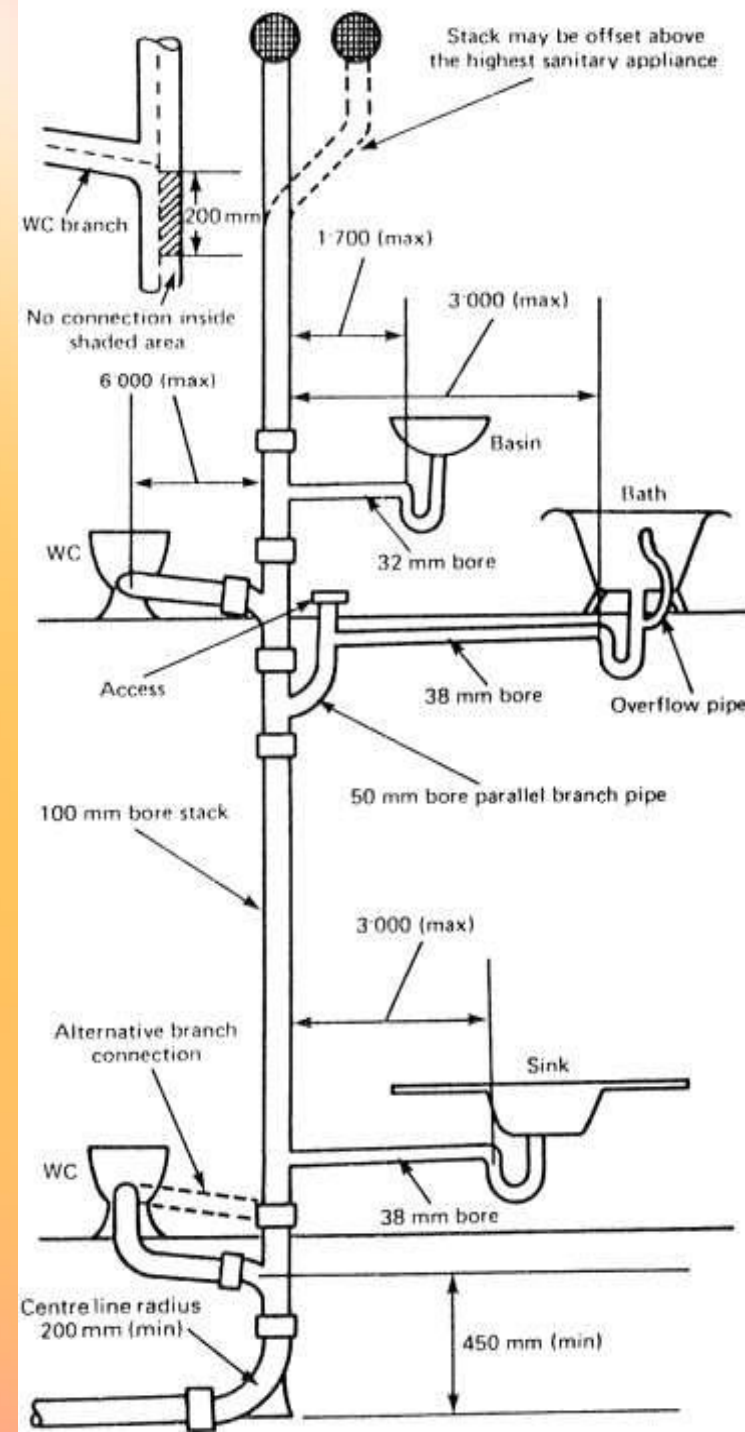

# Modified single stack system

Close grouping of the sanitary appliances  $\Rightarrow$  install the branch waste and soil pipes without the need for individual branch ventilating pipes.

To prevent the loss of trap water seals  $\Rightarrow$  WC branch pipe min. 100 mm bore and the angle  $\theta = 90.5^\circ$  to  $95^\circ$ .

To prevent the loss of trap water seals  $\Rightarrow$  basin main waste pipe min. 50 mm bore and the angle  $\theta = 91^\circ$  to  $92.5^\circ$ .

Five basins or more / length of the main waste pipe exceeds 4.5 m  $\Rightarrow$  a 25 mm bore vent pipe connected to main waste pipe at a point between

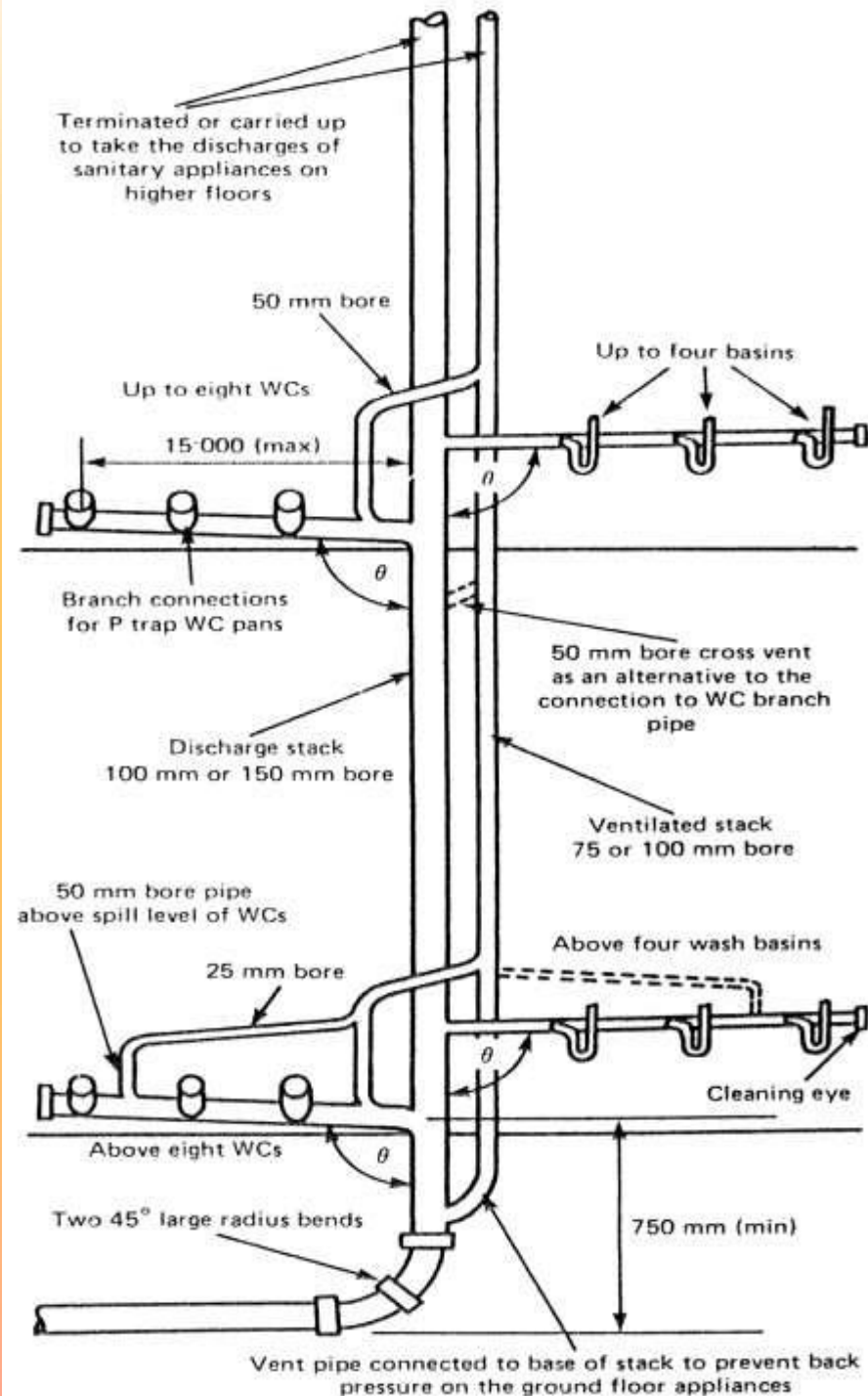

**THANK YOU VERY MUCH FOR  
YOUR ATTENTION, WITH BEST  
WISHES FOR YOUR SUPPORT.**