

DC Machines

Subject Code: 26742

$$T=3$$

$$P=3$$

$$C=4$$

Maxwell's Cork screw Rule :

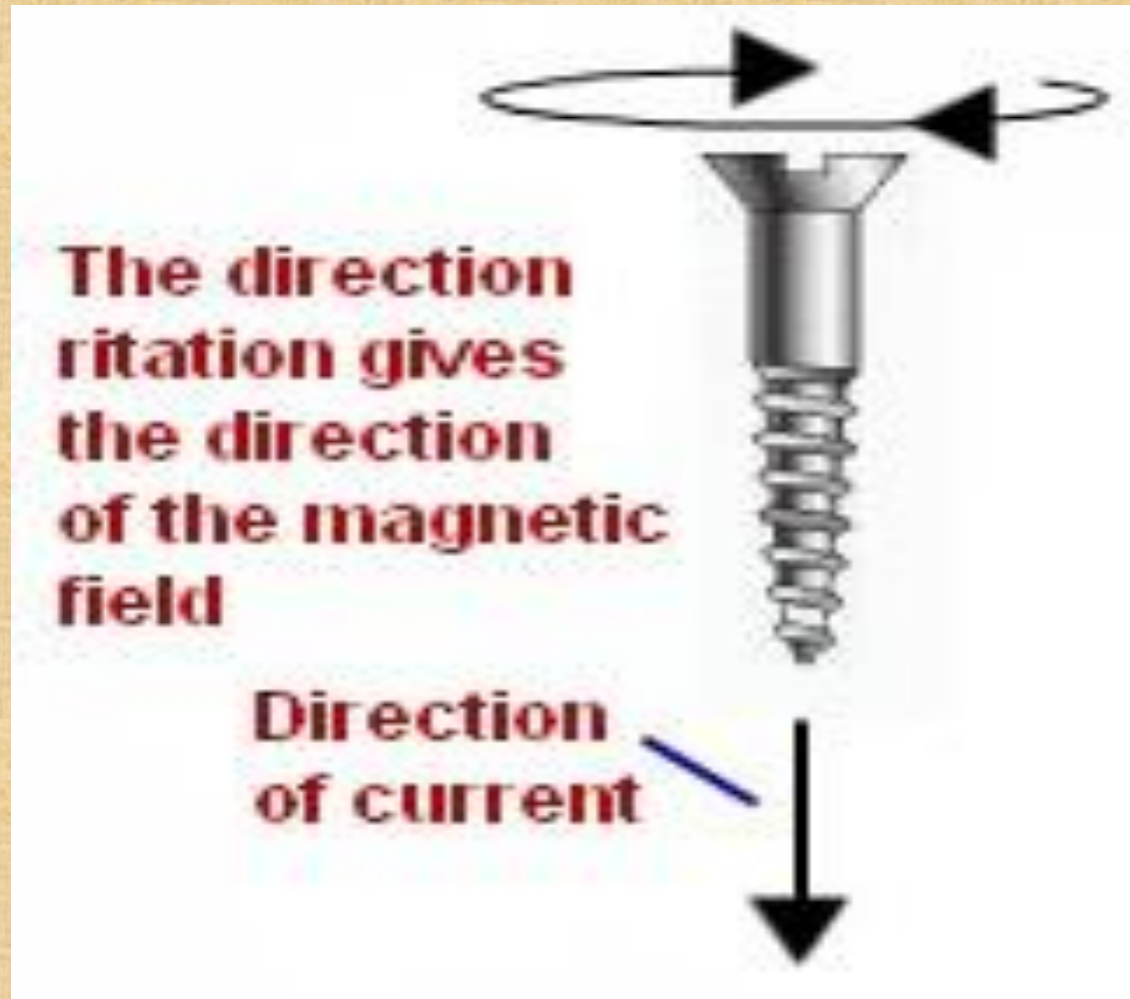

Maxwell's Cork screw Rule :

Hold the cork screw in yr right hand and rotate it in clockwise in such a way that it advances in the direction of current. Then the direction in which the hand rotates will be the direction of magnetic lines of force .

Fleming's left hand rule

Left Hand Rule

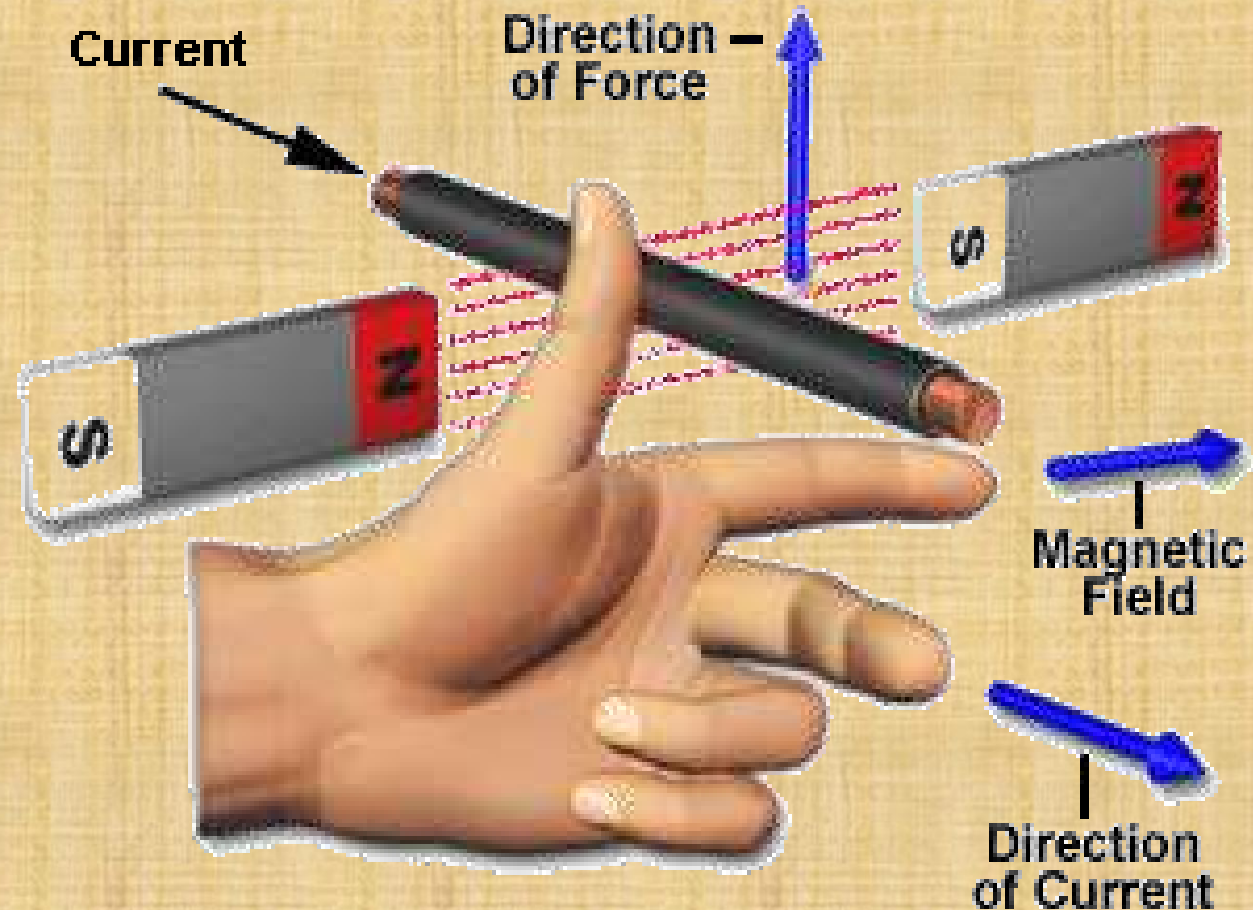

Fleming's left hand rule

- ▶ Used to determine the direction of force acting on a current carrying conductor placed in a magnetic field .
- ▶ The middle finger , the fore finger and thumb of the left hand are kept at right angles to one another .
 - ▶ The middle finger represent the direction of current
 - ▶ The fore finger represent the direction of magnetic field
 - ▶ The thumb will indicate the direction of force acting on the conductor .

This rule is used in motors.

Fleming's Right hand rule

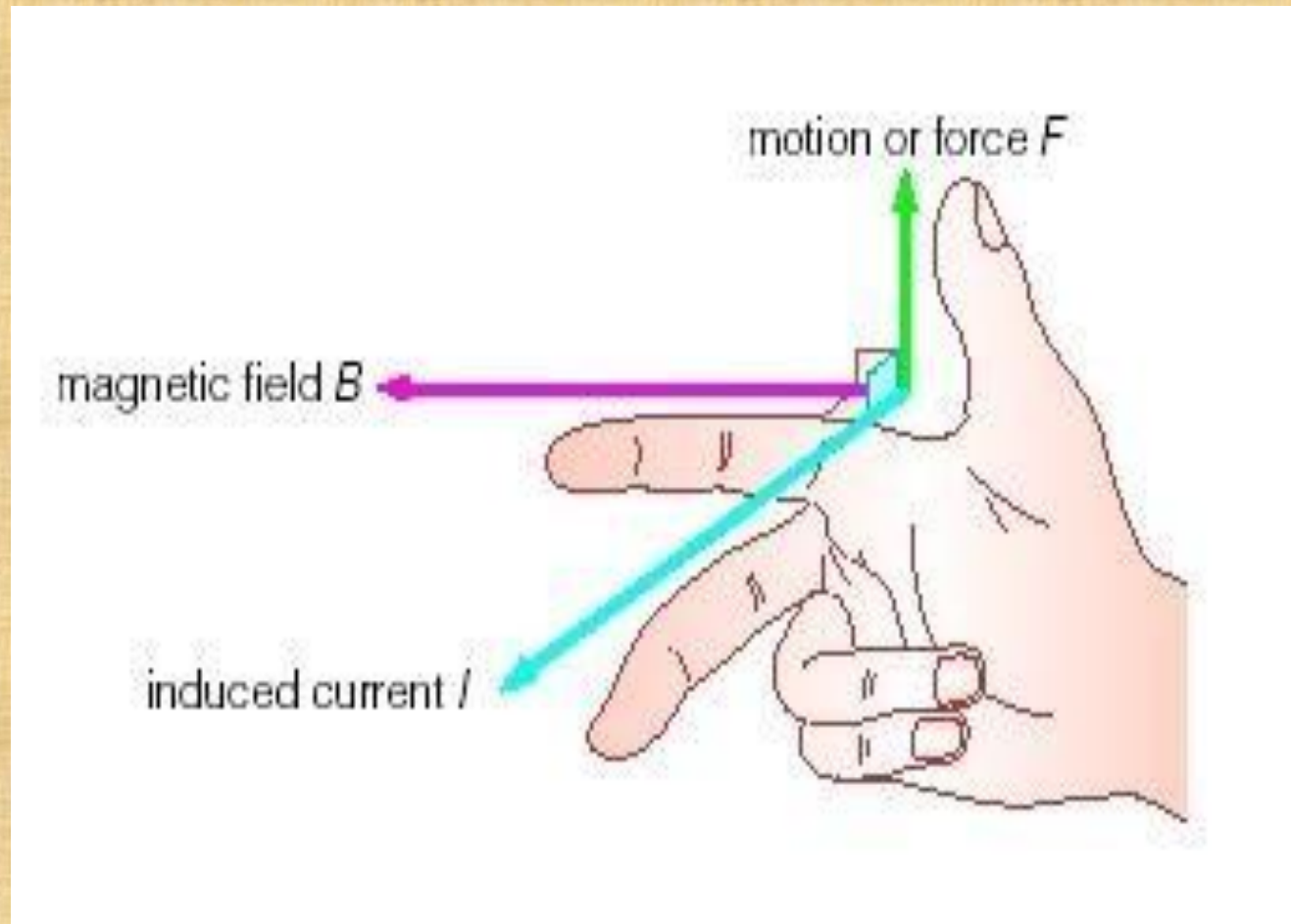

Fleming's Right hand rule

- ▶ Used to determine the direction of emf induced in a conductor
- ▶ The middle finger , the fore finger and thumb of the right hand are kept at right angles to one another.
 - ▶ The fore finger represent the direction of magnetic field
 - ▶ The thumb represent the direction of motion of the conductor
 - ▶ The middle finger will indicate the direction of the induced emf .

This rule is used in DC Generators

Len's Law

The direction of induced emf is given by Lenz's law .

According to this law, the induced emf will be acting in such a way so as to oppose the very cause of production of it .

- ▶ $e = -N (d\Phi/dt)$ volts

DC Generator

Mechanical energy is converted to electrical energy

Three requirements are essential

1. Conductors
2. Magnetic field
3. Mechanical energy

Working principle

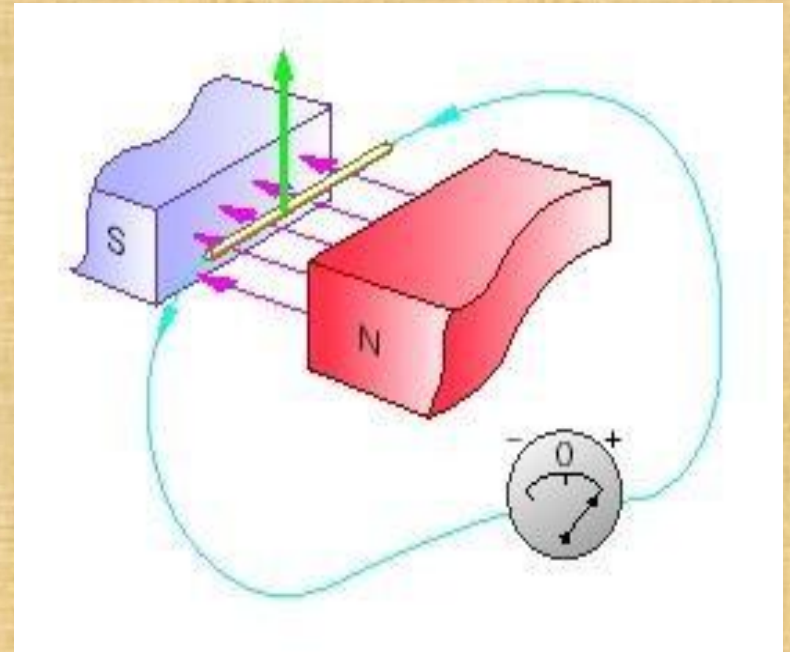

- ▶ A generator works on the principles of Faraday's law of electromagnetic induction
- ▶ Whenever a conductor is moved in the magnetic field, an emf is induced and the

magnitude of the induced emf is directly proportional to the rate of change of flux linkage.

▶ This emf causes a current flow if the conductor circuit is closed .

DC Machine

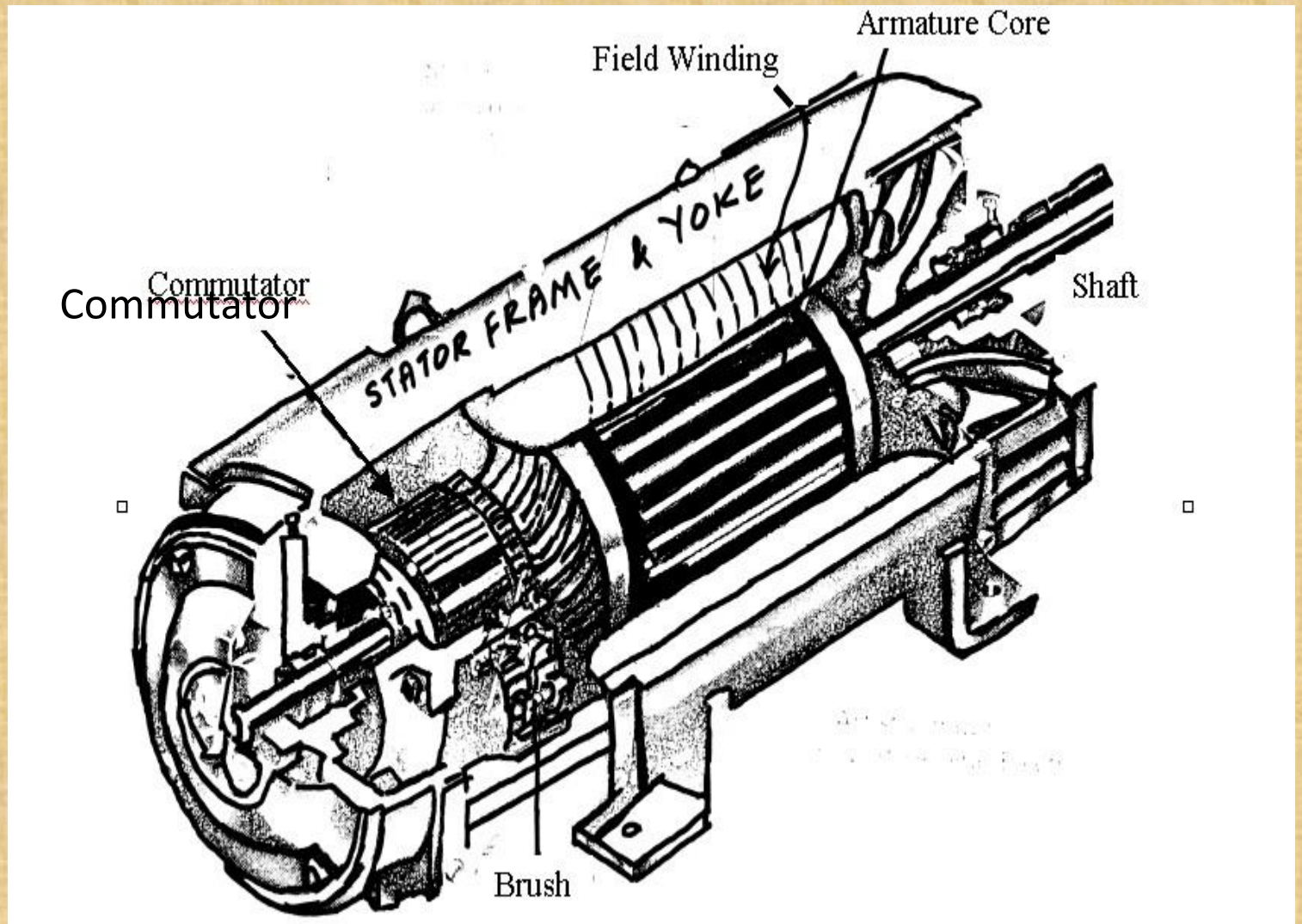

Sectional view of a DC machine

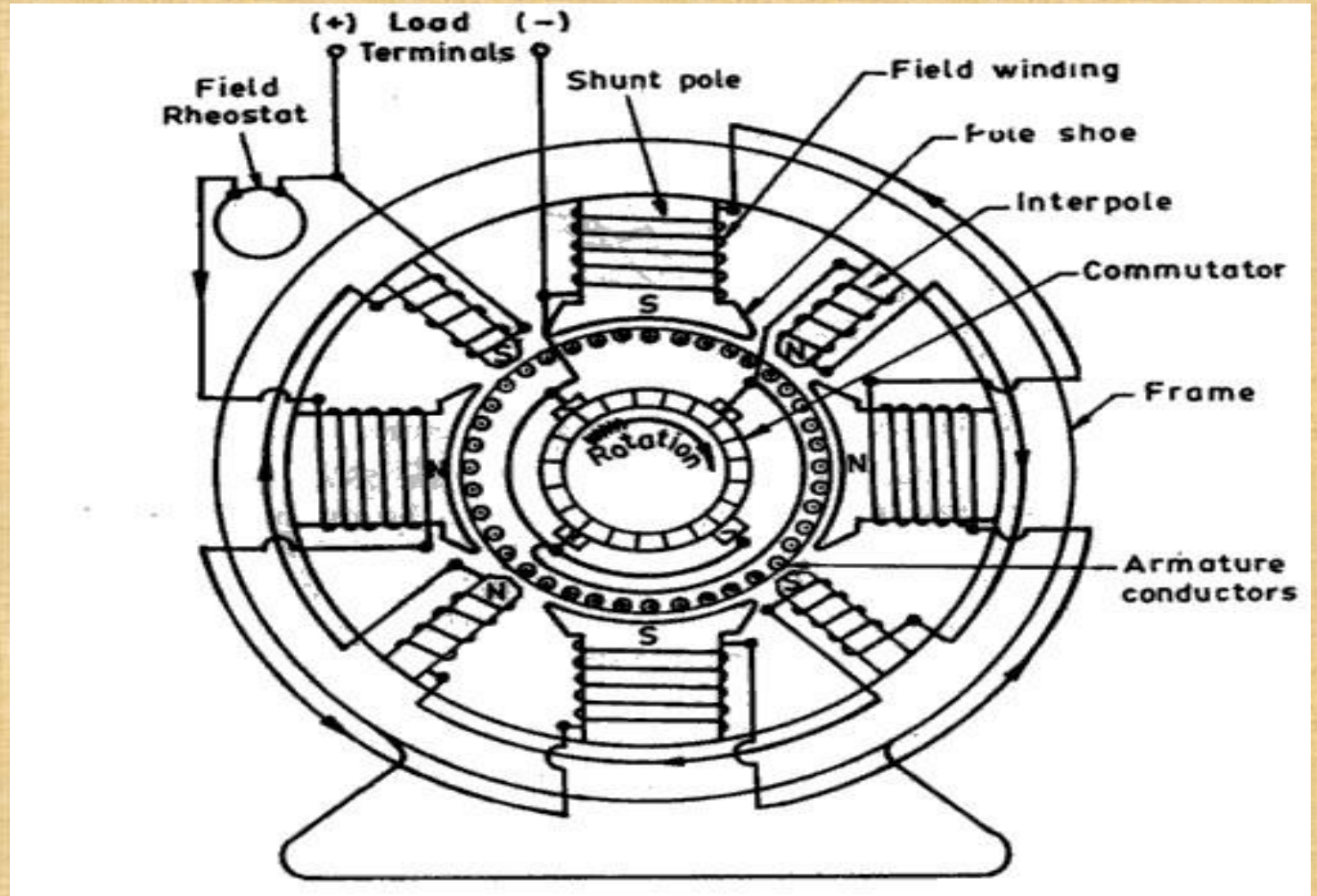

Construction of DC Generator

- Field system
- Armature core
- Armature winding

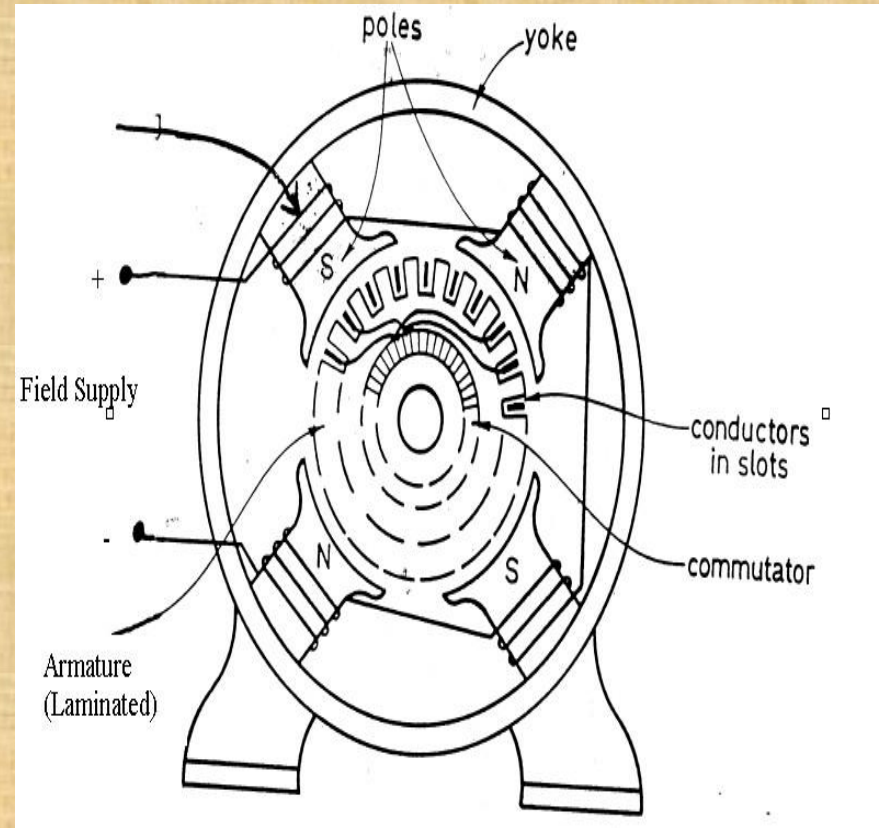

▸ Commutator

▸ Brushes

Field winding



Rotor and rotor winding

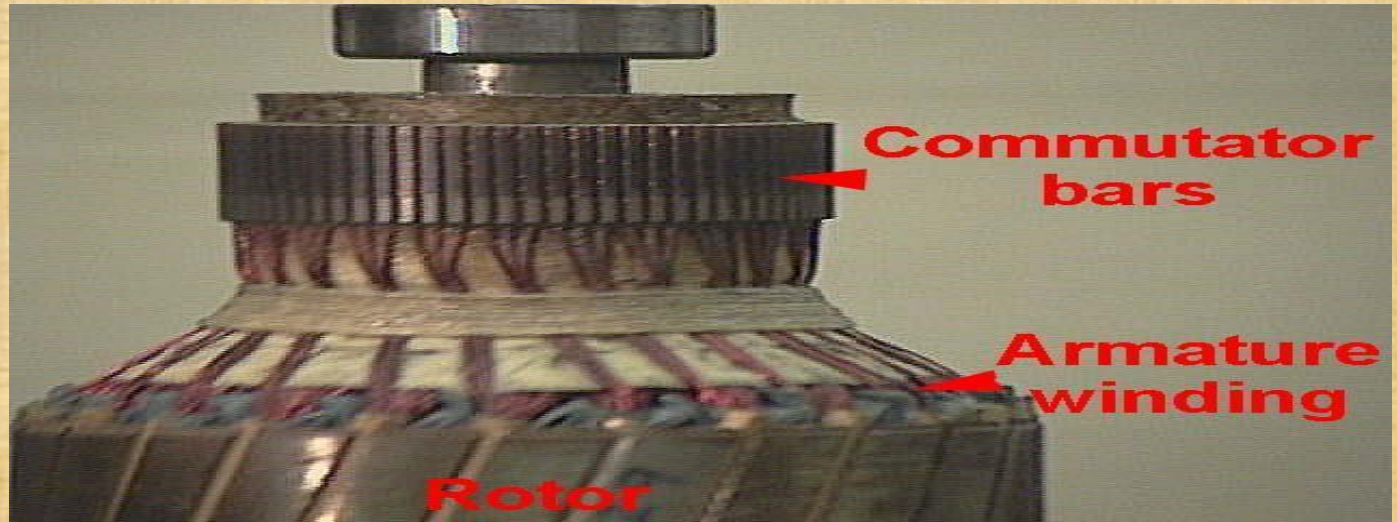

Working principle of DC motor

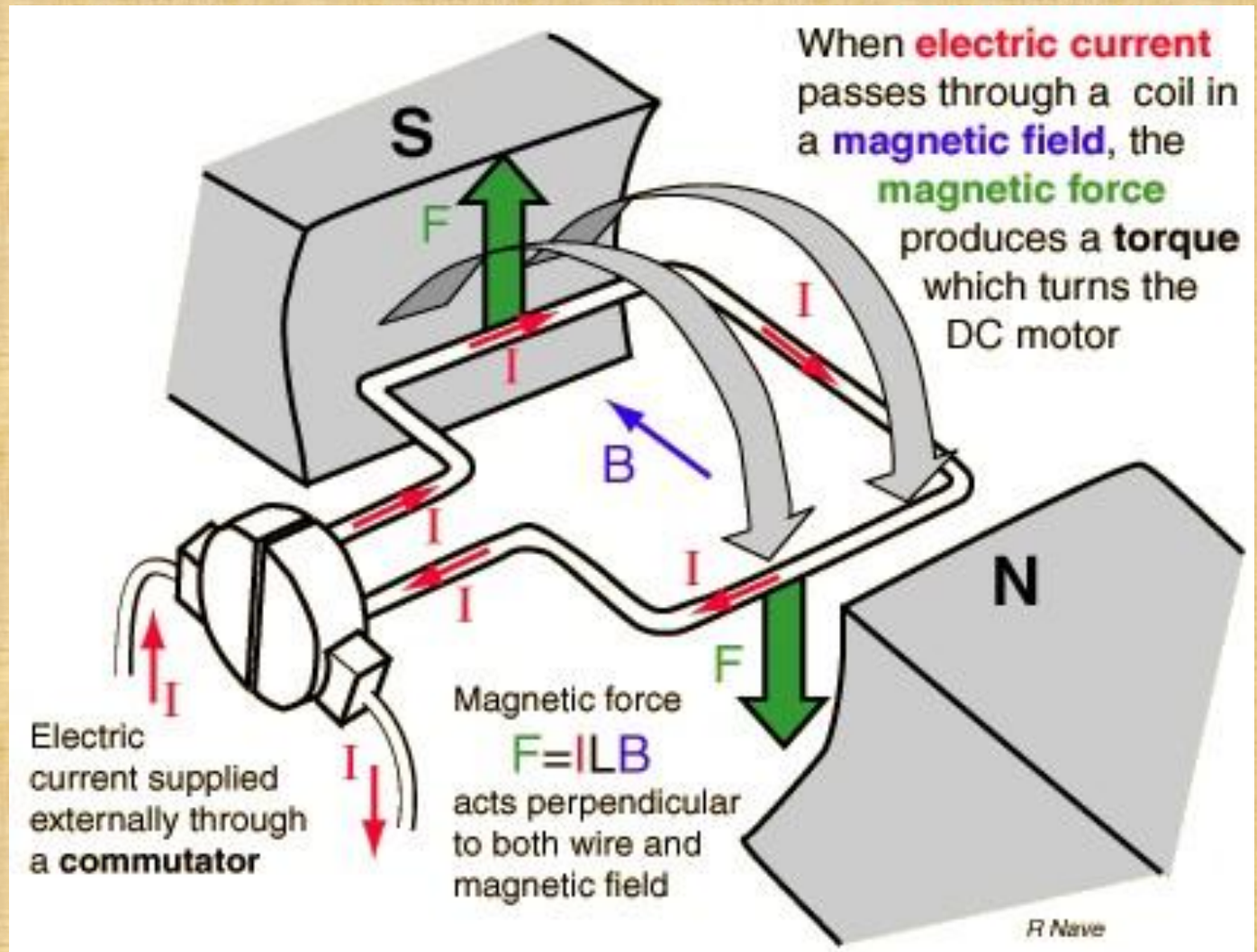

Working principle of DC motor

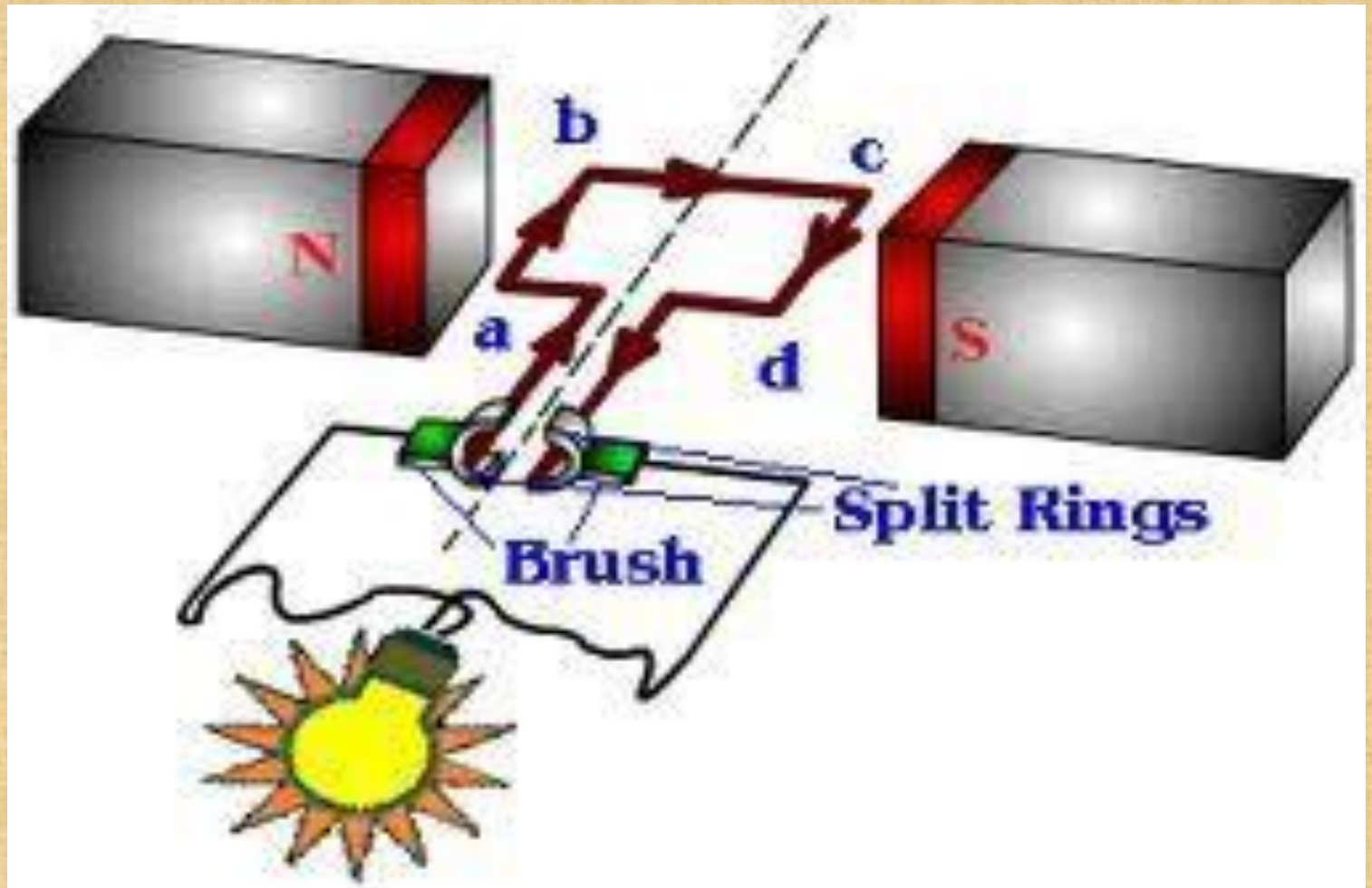

Force in DC motor

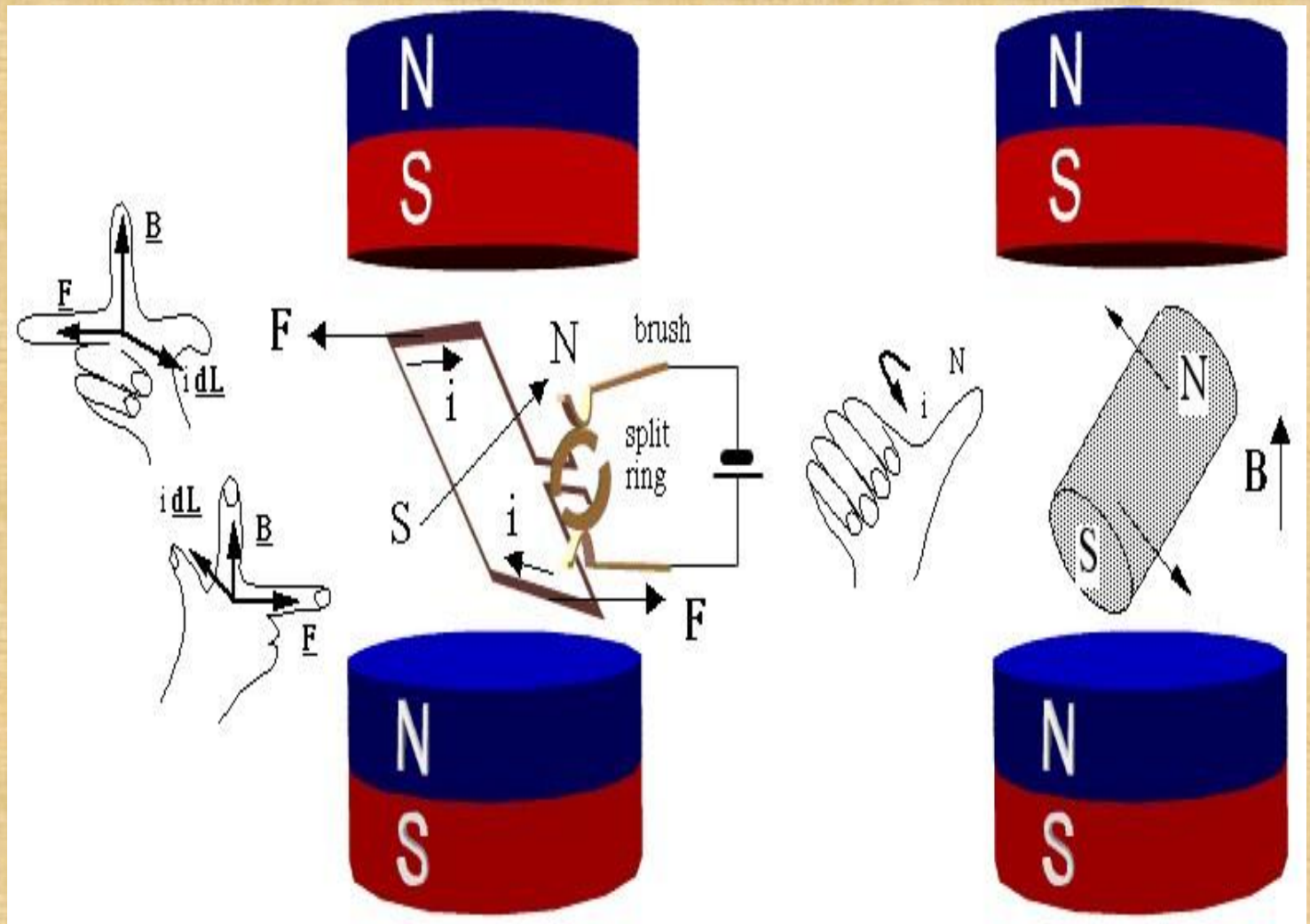

Armature winding

There are 2 types of winding

Lap and Wave winding

Lap
winding ►

$$A = P$$

divided into
no. of sections
equal to the no
of poles

Wave winding ► A

$$= 2$$

► The
armature
windings
are

- ▶ it is used in low current output and high voltage.
- ▶ 2 brushes

Field system

- ▶ It is for uniform magnetic field within which the armature rotates.
- ▶ Electromagnets are preferred in comparison with permanent magnets

- ▶ They are cheap , smaller in size , produce greater magnetic effect and
- ▶ Field strength can be varied

Field system consists of the following parts

- ▶ Yoke
- ▶ Pole cores

▶ Pole shoes ▶

Field coils

Armature core

- ▶ The armature core is cylindrical
- ▶ High permeability silicon steel stampings
- ▶ Impregnated

▶ Lamination is to reduce the eddy current loss

Commutator

- ★ Connect with external circuit
- ★ Converts ac into unidirectional current
- ★ Cylindrical in shape
- ★ Made of wedge shaped copper segments
- ★ Segments are insulated from each other

- ★ Each commutator segment is connected to armature conductors by means of a cu strip called riser.
- ★ No of segments equal to no of coils

Carbon brush

- ★ Carbon brushes are used in DC machines because they are soft materials
- ★ It does not generate spikes when they contact commutator
- ★ To deliver the current thro armature

- ★ Carbon is used for brushes because it has negative temperature coefficient of resistance
- ★ Self lubricating , takes its shape , improving area of contact

Brush rock and holder



EMF equation

Let,

- ▶ Φ = flux per pole in weber
- ▶ Z = Total number of conductor
- ▶ P = Number of poles
- ▶ A = Number of parallel paths
- ▶ N = armature speed in rpm

▶ E_g = emf generated in any one of the parallel paths

EMF equation

Flux cut by 1 conductor

in 1 revolution

$$= P * \phi$$

Flux cut by 1 conductor in

60 sec

$$= P \phi N / 60$$

Avg emf generated in 1

conductor

$$= P \phi N / 60$$

Number of conductors in
each parallel path $= Z / A$

$$E_g = P\phi NZ/60A$$

Types of DC Generator

DC generators are generally classified according to their method of excitation .

- ▶ Separately excited DC generator

- ▶ Self excited D C generator

Further classification of DC Generator

- ▶ Series wound generator
- ▶ Shunt wound generator
- ▶ Compound wound generator
 - Short shunt
 - Long shunt ●
 - compound

Losses in DC Generators

1. Copper losses or variable losses
2. Stray losses or constant losses

Stray losses : consist of (a) iron losses or core losses and (b) windage and friction losses .

Iron losses : occurs in the core of the machine due to change of magnetic flux in the core . Consist of hysteresis loss and eddy current loss. Hysteresis loss depends upon the frequency , Flux density , volume and type of the core .

Losses

Hysteresis loss depends upon the frequency , Flux density , volume and type of the core .

Eddy current losses : directly proportional to the flux density , frequency , thickness of the lamination .

Windage and friction losses are constant due to the opposition of wind and friction .

Applications

Shunt Generators:

- a. in electro plating
- b. for battery recharging
- c. as exciters for AC generators.

Series Generators :

- A. As boosters
- B. As lighting arc lamps

DC Motors

Converts Electrical energy into Mechanical energy

Construction : Same for Generator and motor

Working principle : Whenever a current carrying conductor is placed in the magnetic field , a force is set up on the conductor.

Back emf

The induced emf in the rotating armature conductors always acts in the opposite direction of the supply voltage .

According to the Lenz's law, the direction of the induced emf is always so as to oppose the cause producing it .

In a DC motor , the supply voltage is the cause and hence this induced emf opposes the supply voltage.

Classification of DC motors

DC motors are mainly classified into three types as listed below:

- Shunt motor
- Series motor
- Compound motor
 - Differential compound

■ Cumulative compound

Torque

The turning or twisting force about an axis is called torque .

▶ $P = T * 2 \pi N / 60$

▶ $E_b I_a = T_a * 2 \pi N / 60$

▶ $T \propto \phi I_a$

▶ $T_a \propto I_a^2$

Characteristic of DC motors

- T/ I_a characteristic
- N/ I_a characteristic
- N/T characteristic

Speed control of DC motors

According to the speed equation of a dc motor

$$N \propto E_b / \phi$$
$$\propto V - I_a R_a / \phi$$

Thus speed can be controlled by-

Flux control method: By Changing the flux by controlling the current through the field winding.

Armature control method: By Changing the armature resistance which in turn changes the voltage applied across the armature

Flux control

Advantages of flux control:

- It provides relatively smooth and easy control
- Speed control above rated speed is possible
- As the field winding resistance is high the field current is small. Power loss in the external resistance is small .

Hence this method is economical Disadvantages:

- Flux can be increased only upto its rated value
- High speed affects the commutation, motor operation becomes unstable

Armature voltage control method

- ▶ The speed is directly proportional to the voltage applied across the armature .
- ▶ Voltage across armature can be controlled by adding a variable resistance in series with the armature

Potential divider control :

If the speed control from zero to the rated speed is required , by rheostatic method then the voltage

across the armature can be varied by connecting rheostat in a potential divider arrangement .

Starters for DC motors

Needed to limit the starting current .

1. Two point starter
2. Three point starter
3. Four point starter

Testing of DC machines

To determine the efficiency of as DC motor , the output and input should be known.

There are two methods.

- ▶ The load test or The direct method
- ▶ The indirect method

Direct method: In this method , the efficiency is determined by knowing the input and output power of the motor.

Indirect method: Swinburne's test is an indirect method of testing DC shunt machines to predetermine the efficiency , as a motor and as a Generator. In this method, efficiency is calculated by determining the losses .

Applications:

Shunt Motor:



Blowers and fans



Centrifugal and reciprocating pumps



Lathe machines



Machine tools



Milling machines



Drilling machines

Applications:

Series Motor:

🍷 Cranes

🍷 Hoists , Elevators 🍷

Trolleys

🍷 Conveyors

🍷 Electric locomotives

Applications:

Cumulative compound Motor:

🍷 Rolling mills

 Punches 

Shears

 Heavy planers

 Elevators

-

-

Thanks





DC Machines

Subject Code: 26742

Working principle of DC motor

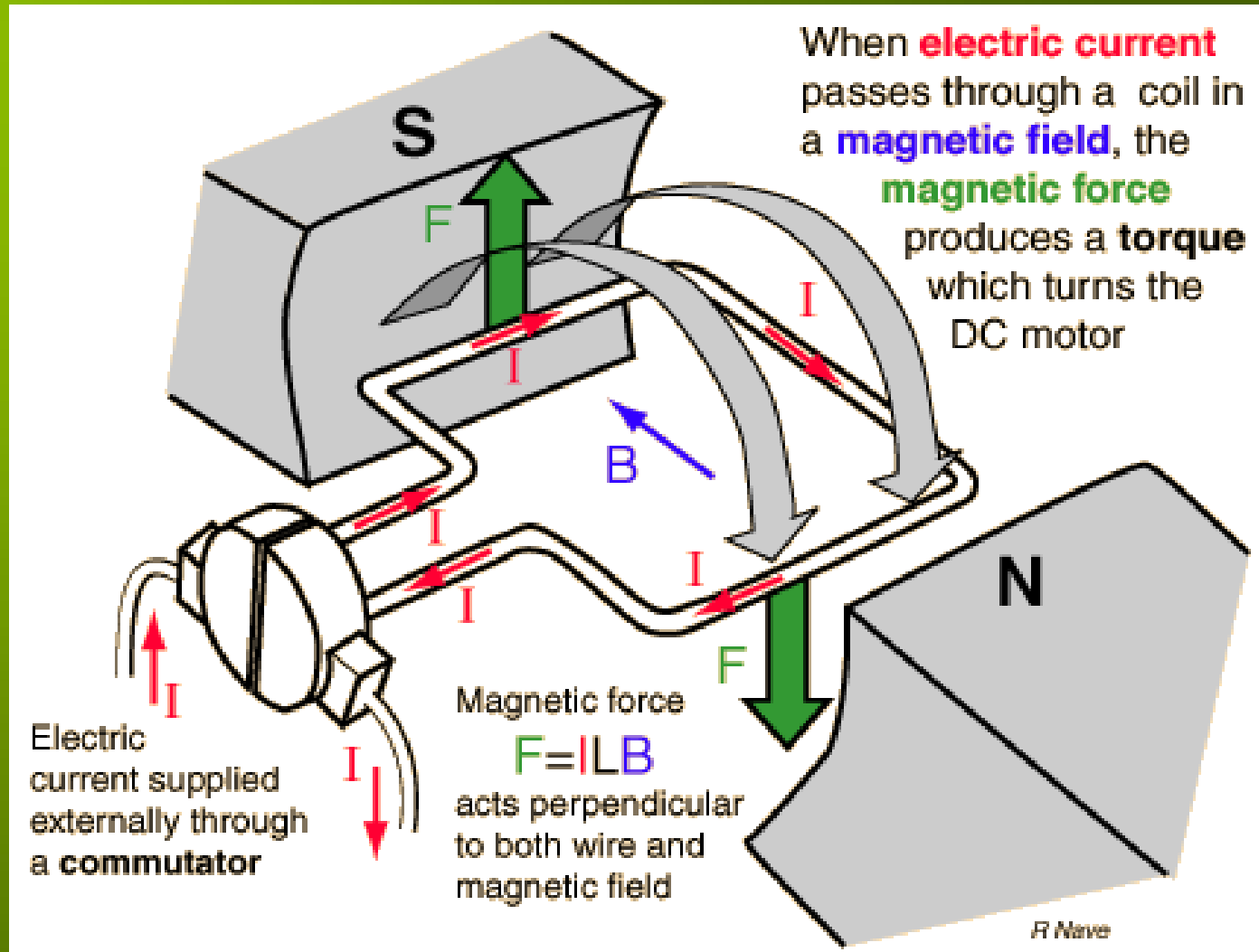

Working principle of DC motor

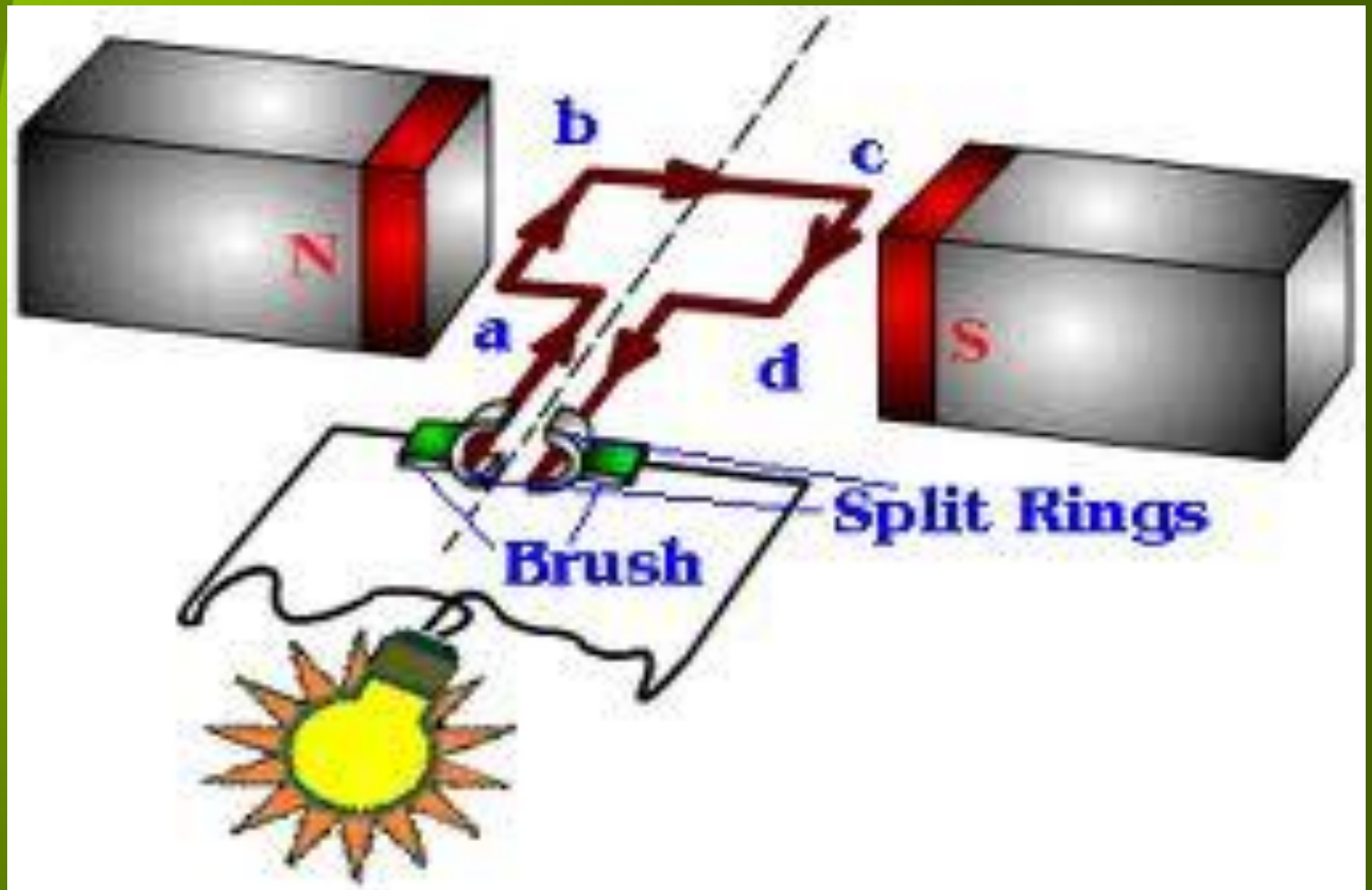

Force in DC motor

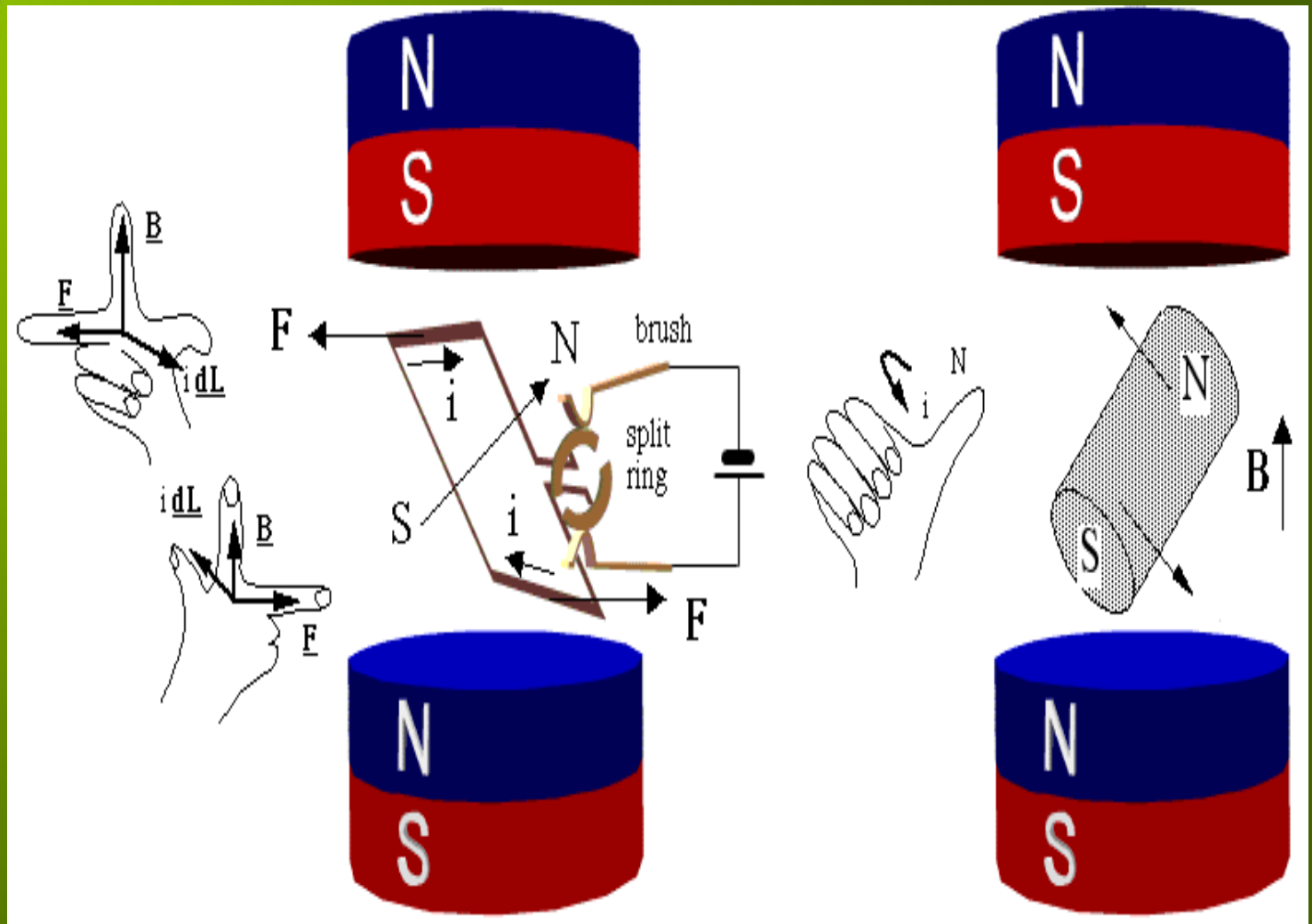

Armature winding

There are 2 types of winding

Lap and Wave winding

Lap winding

- ▶ $A = P$
- ▶ The armature windings are divided into no. of sections equal to the no of poles

Wave winding

- ▶ $A = 2$
- ▶ It is used in low current output and high voltage.
- ▶ 2 brushes

Field system

- ▶ It is for uniform magnetic field within which the armature rotates.
- ▶ Electromagnets are preferred in comparison with permanent magnets
- ▶ They are cheap , smaller in size , produce greater magnetic effect and
- ▶ Field strength can be varied



Field system consists of the following parts

- ▶ Yoke

- ▶ Pole cores

- ▶ Pole shoes

- ▶ Field coils

Armature core

- ▶ The armature core is cylindrical
- ▶ High permeability silicon steel stampings
- ▶ Impregnated
- ▶ Lamination is to reduce the eddy current loss

Commutator

- ★ Connect with external circuit
- ★ Converts ac into unidirectional current
- ★ Cylindrical in shape
- ★ Made of wedge shaped copper segments
- ★ Segments are insulated from each other
- ★ Each commutator segment is connected to armature conductors by means of a cu strip called riser.
- ★ No of segments equal to no of coils

Carbon brush

- ★ Carbon brushes are used in DC machines because they are soft materials
- ★ It does not generate spikes when they contact commutator
- ★ To deliver the current thro armature
- ★ Carbon is used for brushes because it has negative temperature coefficient of resistance
- ★ Self lubricating , takes its shape , improving area of contact

Brush rock and holder



Carbon brush

- ▶ Brush leads (pig tails)
- ▶ Brush rocker (brush gear)
- ▶ Front end cover
- ▶ Rear end cover
- ▶ Cooling fan
- ▶ Bearing
- ▶ Terminal box

EMF equation

Let,

- ▶ Φ = flux per pole in weber
- ▶ Z = Total number of conductor
- ▶ P = Number of poles
- ▶ A = Number of parallel paths
- ▶ N = armature speed in rpm
- ▶ E_g = emf generated in any one of the parallel path

EMF equation

Flux cut by 1 conductor
in 1 revolution $= P * \phi$

Flux cut by 1 conductor in
60 sec $= P \phi N / 60$

Avg emf generated in 1
conductor $= P\phi N / 60$

Number of conductors in
each parallel path $= Z / A$

$$E_g = P\phi NZ / 60A$$



Types of DC Generator

DC generators are generally classified according to their method of excitation .

- ▶ Separately excited DC generator
- ▶ Self excited DC generator



Further classification of DC Generator

- ▶ Series wound generator
- ▶ Shunt wound generator
- ▶ Compound wound generator
 - Short shunt & Long shunt
 - Cumulatively compound
&
Differentially compound



Characteristics

- ▶ No load saturation characteristic (E_o/I_f)
- ▶ Internal or Total characteristic (E/ I_a)
- ▶ External characteristic (V/I)



Critical field resistance

For appreciable generation of emf, the field resistance must be always less than a certain resistance, that resistance is called as the critical resistance of the machine .

General terms used in Armature reaction

Magnetic neutral axis :

It is perpendicular to the lines of force between the two opposite adjacent poles.

Leading pole Tip (LPT) :

It is the end of the pole which first comes in contact with the armature.

Trailing pole tip :

It is the end of the pole which comes in contact later with the armature.

Armature Reaction

Interaction of Main field flux with Armature field flux

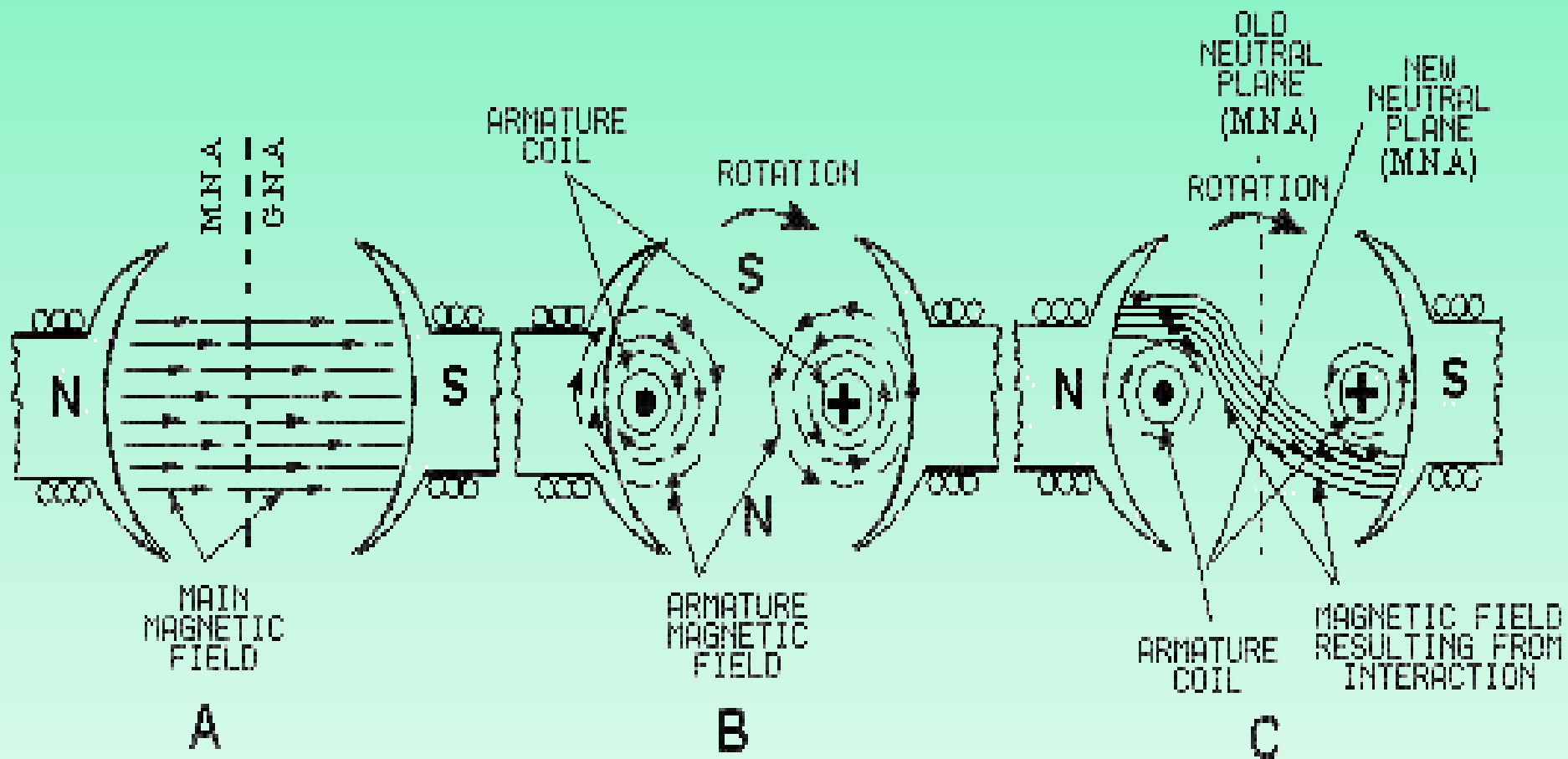



Effects of Armature Reaction

- It decreases the efficiency of the machine
- It produces sparking at the brushes
- It produces a demagnetising effect on the main poles
- It reduces the emf induced
- Self excited generators some times fail to build up emf

Armature reaction remedies

1. Brushes must be shifted to the new position of the MNA
2. Extra turns in the field winding
3. Slots are made on the tips to increase the reluctance
4. The laminated cores of the shoe are staggered
5. In big machines the compensating winding at pole shoes produces a flux which just opposes the armature mmf flux automatically.

Commutation

The background of the slide features a vibrant green hillside. In the distance, there are several trees, including a prominent one with bright purple blossoms. A soft, multi-colored rainbow arches across the sky above the trees.

The change in direction of current takes place when the conductors are along the brush axis .

During this reverse process brushes short circuit that coil and undergone commutation

Due to this sparking is produced and the brushes will be damaged and also causes voltage dropping.

Losses in DC Generators

1. Copper losses or variable losses
2. Stray losses or constant losses

Stray losses : consist of (a) iron losses or core losses and (b) windage and friction losses .

Iron losses : occurs in the core of the machine due to change of magnetic flux in the core .
Consist of hysteresis loss and eddy current loss.

Hysteresis loss depends upon the frequency ,
Flux density , volume and type of the core .



Losses

Hysteresis loss depends upon the frequency ,
Flux density , volume and type of the core .

Eddy current losses : directly proportional to
the flux density , frequency , thickness of the
lamination .

Windage and friction losses are constant due to
the opposition of wind and friction .

Applications



Shunt Generators:

- a. in electro plating
- b. for battery recharging
- c. as exciters for AC generators.

Series Generators :

- A. As boosters
- B. As lighting arc lamps

DC Motors

Converts Electrical energy into Mechanical energy

Construction : Same for Generator and motor

Working principle : Whenever a current carrying conductor is placed in the magnetic field , a force is set up on the conductor.



Back emf

The induced emf in the rotating armature conductors always acts in the opposite direction of the supply voltage .

According to the Lenz's law, the direction of the induced emf is always so as to oppose the cause producing it .

In a DC motor , the supply voltage is the cause and hence this induced emf opposes the supply voltage.

Classification of DC motors

DC motors are mainly classified into three types as listed below:

- Shunt motor
- Series motor
- Compound motor
 - Differential compound
 - Cumulative compound

Torque

The turning or twisting force about an axis is called torque .

▶ $P = T * 2 \pi N / 60$

▶ $E_b I_a = T_a * 2 \pi N / 60$

▶ $T \propto \phi I_a$

▶ $T_a \propto I_{2a}$

Characteristic of DC motors

- T/ I_a characteristic
- N/ I_a characteristic
- N/T characteristic

Speed control of DC motors

According to the speed equation of a dc motor

$$N \propto E_b / \phi$$
$$\propto V - I_a R_a / \phi$$

Thus speed can be controlled by-

Flux control method: By Changing the flux by controlling the current through the field winding.

Armature control method: By Changing the armature resistance which in turn changes the voltage applied across the armature

Flux control

Advantages of flux control:

- It provides relatively smooth and easy control
- Speed control above rated speed is possible
- As the field winding resistance is high the field current is small. Power loss in the external resistance is small. Hence this method is economical

Disadvantages:

- Flux can be increased only upto its rated value
- High speed affects the commutation, motor operation becomes unstable

Armature voltage control method

- ▶ The speed is directly proportional to the voltage applied across the armature .
- ▶ Voltage across armature can be controlled by adding a variable resistance in series with the armature

Potential divider control :

If the speed control from zero to the rated speed is required , by rheostatic method then the voltage across the armature can be varied by connecting rheostat in a potential divider arrangement .

Starters for DC motors

Needed to limit the starting current .

1. Two point starter
2. Three point starter
3. Four point starter

Testing of DC machines

To determine the efficiency of a DC motor, the output and input should be known.

There are two methods.

- ▶ The load test or The direct method
- ▶ The indirect method

Direct method: In this method, the efficiency is determined by knowing the input and output power of the motor.

Indirect method: Swinburne's test is an indirect method of testing DC shunt machines to predetermine the efficiency, as a motor and as a Generator. In this method, efficiency is calculated by determining the losses.

Applications:

Shunt Motor:

- 🌸 Blowers and fans
- 🌸 Centrifugal and reciprocating pumps
- 🌸 Lathe machines
- 🌸 Machine tools
- 🌸 Milling machines
- 🌸 Drilling machines

Applications:

Series Motor:

- 🍷 Cranes
- 🍷 Hoists , Elevators
- 🍷 Trolleys
- 🍷 Conveyors
- 🍷 Electric locomotives

Applications:

Cumulative compound Motor:

- Rolling mills
- Punches
- Shears
- Heavy planers
- Elevators