

Sylhet Engineering College, Sylhet
(Shahjalal University of Science & Technology, Sylhet)
Department of Civil Engineering

Final Examination, 2024
Course No: CE 785
Time: 02 (Two) hours

4th year 1st Semester
Course Title: Fundamentals of Earthquake Engineering
Full Marks: 40

N.B. : (i) Answer any two questions from each PART
(iii) Marks allotted are indicated in the margin

(ii) Use separate answer scripts for each PART
(iv) Special Instruction (if any) N/A

PART A

(Answer any two questions)

1. (a) What is box action in masonry buildings? How can old masonry buildings be strengthened? 04
- (b) Calculate the base shear produced due to earthquake for a residential building with a special moment resisting frame ($C_t=0.0466$ and $m=0.9$) in Mymensingh. Dead load on floor = 5 kips/ sft. The building is 30 ft X 50 ft in plan and 4-storied, each having a height of 10 ft. Soil class: SD. Use Figure 01 and assume the reasonable data if required. Also, determine the floor-wise lateral loads due to the earthquake. 06

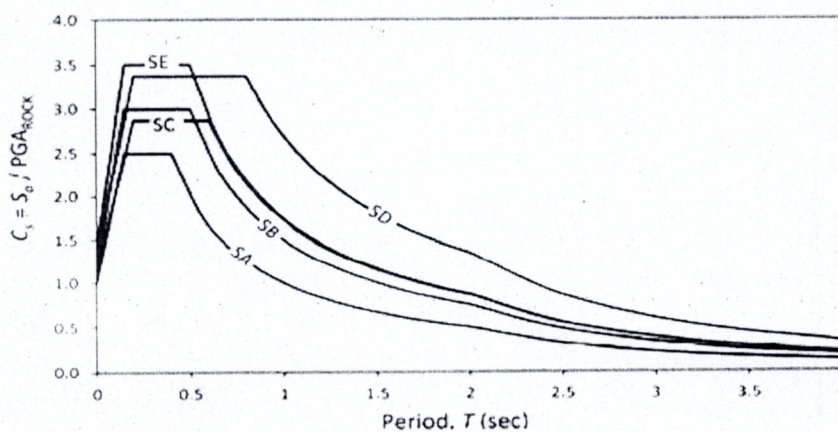

Figure 01: Normalized design acceleration response spectrum for different site classes.

2. (a) Why are masonry buildings more vulnerable to earthquakes? How do masonry buildings with large openings fail in an earthquake? How can it be avoided? 05
- (b) What is the peak ground acceleration (PGA)? Show the relation between PGA and MMI. 03
- (c) What is the 'strong column, weak beam' theory? 02
3. (a) Where do most of the earthquakes occur? In recent time, Sylhet city experienced a large number of earthquake. What is the main reason for this? Explain on your own judgment. 03
- (b) What is fault? Describe the different types of faults with neat sketches. Why is studying fault necessary for Earthquake or Geotechnical specialists? 03
- (c) Define the different types of seismic waves with appropriate figure. Among them which one is most devastating and faster –explain properly 04

PART B

(Answer any two questions)

4. (a) Define Magnitude. What are the differences between magnitude 7.8 and magnitude 5.6 in terms of amplitude and energy discharge? 06
What is Intensity? What happens if intensity is IX? How is intensity used in seismic design? What will be the maximum intensity if the magnitude is 7.8?
- (b) Write short notes on (i) Faults (ii) Liquefaction. 04
5. (a) Describe briefly the major building irregularities that can cause severe damage during an earthquake with sketches. 06
- (b) Sketch to explain the Response reduction factor. How is it related to structural types? 04
6. (a) Calculate the equivalent static lateral loads produce due to earthquake for a residential building in Sylhet city with special moment resisting frame. Dead load on floor= 6 kips/sft. The building is 40 ft x 60 ft in plan and 7 storied, each having a height of 10 ft. Assume the reasonable data if required 05
- (b) Describe different types of plan irregularity with appropriate figure and dimension. 02
- (c) Explain the characteristics of earthquake resistance building. 03

Sylhet Engineering College, Sylhet
(Shahjalal University of Science & Technology)
Department of Civil Engineering

Final Examination, 2024

4th Year 1st Semester

Course No.: CE 767

Course Title: Irrigation and Flood control

Time: 02 (Three) hours

Full Marks: 40

N.B. : (i) Answer any two questions from each PART

(ii) Use separate answer scripts for each PART

(iii) Marks allotted are indicated in the margin

(iv) Special Instruction (if any)-----N/A-----

PART- A

(Answer any two questions)

1. (a) Discuss sprinkler irrigation method. What are the advantages and disadvantages of sprinkler irrigation method? 4
- (b) What is SAR? What are effects of soluble salts and sodium ions in irrigation water? 2
- (c) What is the classification of irrigation water having the following characteristics: Concentration of Na, Ca, and Mg are 345, 60, and 18 ppm respectively, electrical conductivity is 850 mhos/cm at 25^o C? 4
 - i) What problem might arise in using this water in textured soil?
 - ii) What remedies do you suggest to overcome this trouble?
2. (a) Discuss Duty at various places of an irrigation system with suitable figure. 3
- (b) What is canal lining? Explain briefly the advantages of irrigation canal lining. 3
- (c) The depth of penetrations along the length of border strip irrigation at point 40 meter were probed. Their observed values are 2.3, 2, 1.8, 1.6, and 1.5 meters. Compute the water distribution efficiency. 4
3. (a) Write short notes on kor-watering, irrigation efficiency. 2
- (b) A stream of 130 litres per second was diverted from a canal and 100 litres per-second were delivered to the field. An area of 2 hectares was irrigated in 10 hours. The effective depth of root zone was 1.7 m. The runoff loss in the field was 420 cu.m. The depth of water penetration varied linearly from 1.7 m at the head end of the field to 1.1 m at the tail end. Available moisture holding capacity of the soil is 20 cm per metre depth of soil. It is required to determine the water conveyance efficiency, water application efficiency, water storage efficiency, and water distribution efficiency. Irrigation was started at a moisture extraction level to 40% of the available moisture. 6
- (c) Explain optimum utilization of water, cash crops and water distribution efficiency. 2

PART- B

(Answer any two questions)

- 4 (a) Differentiate between Alluvial & Non alluvial canals. 2
- (b) Design an irrigation canal to carry 70 cumecs of discharge. The chanal is to be laided on a slope so 1:4000. The critical velocity ratio as 1.1. Use kutter rugosity coefficient as 0.023 6
- (c) What are the effects of water logging? How could you control of water logging? 2
- 5 (a) What is flood? Why flood occurs so frequently in Bangladesh? Also mention the flood control measures. 3
- (b) Discuss water distribution system for canal irrigation with neat sketches? 2
- (c) 800 m³ of water is applied to a farmer's rice field of 0.6 hectares. When the moisture content in the soil falls to 60% of the available water between the field capacity (36%) of soil and permanent wilting point (17%) of the soil crop combination, determine the field application efficiency. The root zone depth of rice is 60 cm. Assume porosity = 0.4 5
- 6 (a) What are the advantages of Tile drains. Show that the spacing between tiles is $s = \frac{4k}{q}(b^2 - a^2)$ 5
- (b) In a tile drainage system, the drains are laid with their centres 1.5 m below the ground level. The impervious layer is 9.0 in below the ground level and the average annual rainfall in the area is 80 cm. If 1% of the annual rainfall is to be drained in 24 hours to keep the highest position of the water-table to 1 m below ground level, determine the spacing of the drain pipes. Coefficient of permeability may be taken as 0.001 cm/sec. 5

Sylhet Engineering College, Sylhet
(Shahjalal University of Science & Technology)
Department of Civil Engineering

Final Examination, 2024
 Course No.: CE 753
 Time: 03 (Three) hours

4th Year 1st Semester
 Course Title: Transportation Engineering II
 Full Marks: 60

N.B. : (i) Answer any three questions from each PART
 (iii) Marks allotted are indicated in the margin

(ii) Use separate answer scripts for each PART
 (iv) Special Instruction (if any)-----N/A-----

PART- A

(Answer any three questions)

1. (a) Calculate trip distribution matrix using gravity model. Necessary information is given below 08
 Travel time (min)

Zone	1	2	3
1	0	5	7
2	4	0	6
3	6	6	0

Attraction and Production of trips among the zones

Zone	1	2	3	total
Trip production	140	330	280	750
Trip attraction	300	270	180	750

- (b) Why is origin and destination (OD) survey carried out? 02
2. (a) An urban area is divided into 4 zones for transportation demand analysis. Zone pair trip distribution is given in the table 2 and the zone pair travel time is given in Figure-2 below. Calculate total no. of trip assigned in each link of road. Using all or nothing assignment model. 07

Table 2: Origin- Destination matrix

OD	1	2	3	4
1	0	100	200	300
2	200	0	200	400
3	100	300	0	100
4	200	400	200	0

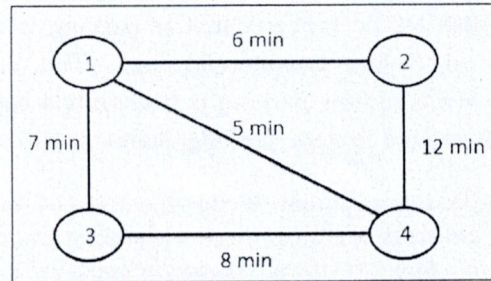

- (b) What are the elements of transportation planning in highway design? 03
3. (a) Explain the 4-stage transport planning model. 03

- (b) Utility function of road user travelling from sub urban to CBD (Central Business District) of Dhaka city using mode CNG and BUS are given below. 07

$$U_{\text{CNG}} = - 0.06 - 0.07(\text{CNG travel time in min.}) - 0.105(\text{parking cost in dollar}) + 0.0001(\text{HH income in dollar})$$

$$U_{\text{bus}} = - 0.07(\text{bus travel time in min.}) - 0.012(\text{bus waiting time in min.}) - 0.66(\text{bus fare in dollar})$$

The travel characteristics pattern between two zones are given below:

Variable	Unit	Auto	Bus
CNG travel time	Minute	40	-
Parking cost	Dollar	8	-
Bus fare	Dollar	-	2
Bus travel time	Minute	-	48
Bus headway	Minute	-	18
Annual house hold income=\$8000.			

- (i) Compute probability as individual will choose CNG for trip
- (ii) In order to increase ridership in public transport which option will consider transport authority?
- (1) Reducing base fare by 40 cents.
 - (2) Doubling parking price
 - (3) Doubling the number of bus
4. (a) Which types of data are required for transportation planning? Mention the main objectives of transportation planning. 03

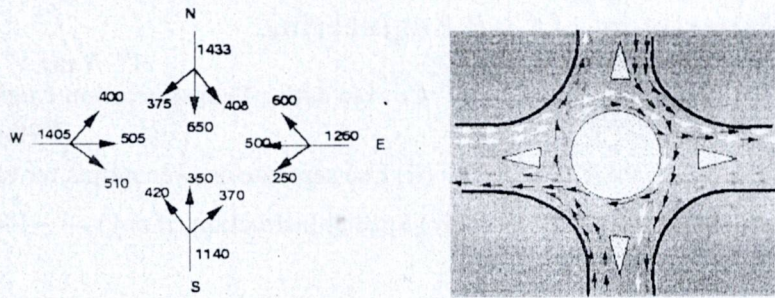

$$Q_p = \{280w(1+e/w)\} * (1-p/3) / (1+w/l)$$

Design a rotary intersection based on following data

Direction (Approach)	Left Turning	Straight	Right Turning
North	245PCU/h	248PCU/h	160PCU/h
South	152	290	199
East	221	163	239
West	163	200	164

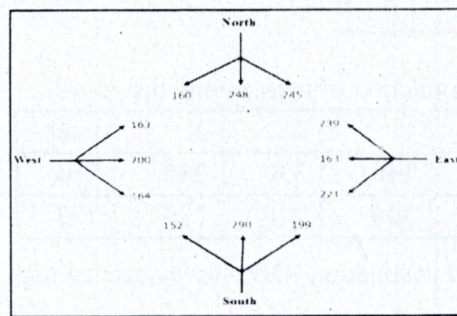
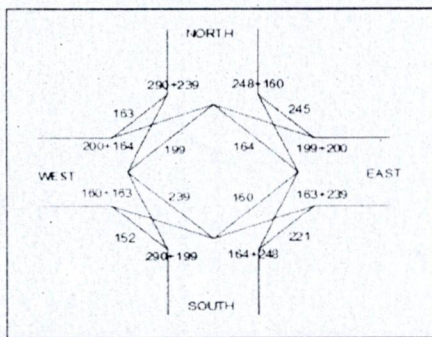

PART- B

(Answer any three questions)

5. The increasing rate of private car usage in Sylhet city as a result of poor government policy is key cause of smooth urban traffic movement. Car parking is one of the concern factors for transport and traffic management in Sylhet commercial area. The co-ordination between parking policy and traffic management revealed how parking is becoming a barrier to the through-traffic operation. To develop an integrated transported system, parking characteristics and parking facilities are essential. 10
 - (a) Define traffic management. Write objectives of traffic management system.
 - (b) Write the contents of transportation planning and parking policy.
 - (c) Mention six elements of transportation planning to ensure sustainability in traffic management.
 - (d) Explain the various factors governing the trip generation.

6. (a) Briefly discuss road safety strategy for sustainable transport system. 05
 - (b) Consider a road segment of 6 lanes with a capacity of 2400 Veh./hr./lane. It was calculated that the storage density is 75veh/m and the segment demand's found to be 2800 veh./hr./lane. If the duration of survey is 2hr, calculate the queue length that is formed due to congestion. 05

7. (a) What are the factors affecting pavement slab thickness in AASHTO method? 02
 - (b) What are the comparison of bitumen and tar used as binder materials? 03
 - (c) Using the following given data, calculate the stress at interior and corner region of a RCC pavement. Wheel load =5100 kg, modulus of elasticity of concrete, E = 3 X10⁵ kg/cm², pavement thickness h=16 cm, modulus of subgrade =8 kg/cm², radius of contact area, a=15 cm. 05

8. (a) The following data were collected for the road development program of a district Sunamganj 05
 - (i) Total area = 9000 km²
 - (ii) Agricultural load = 7000 km²
 - (iii) Length of existing rail track =100km

The pattern of land use and population distribution is given below: (number)

Population	500	1001 to 2000	2001 to 5000	>5000
Number of village and town	450	1175	400	20

Suggest the development program.

- (b) Write causes of road accident in Bangladesh? What are the steps to be taken to prevent road accident? 05

Sylhet Engineering College, Sylhet
(Shahjalal University of Science & Technology)
Department of Civil Engineering

Final Examination, 2024
Course No.: CE 733
Time: 02 (Two) hours

4th Year 1st Semester
Course Title: Environmental Engineering-II
Full Marks: 40

N.B. : (i) Answer any two question from each PART

(ii) Use separate answer scripts for each PART

(iii) Marks allotted are indicated in the margin

(iv) Special Instruction (if any)-----N/A-----

PART- A

(Answer any two questions)

1. (A) Discuss the various stages followed in the construction of sewers. 2
- (B) State the sources of sanitary sewage? What factors affect the quantity of sanitary sewage? 3
- (C) A city with population 50,000 residing in area of 50 Acres. A sewer line is to be designed as a combined sewer section if: 5

- 1) Rate of water supply = 200 lpcd
2) Time of concentration = 50 minutes
3) The surface Area has following run off coefficients:

% Surface Area	Surface	Runoff coefficient
55%	Hard parament	0.85
20%	Unpaired street	0.30
20%	Gardens	0.15
5%	Wooded Area	0.10

Assume the design flow equivalent to wet weather flow plus 1.8 Times the dry weather flow. Assume any other data.

2. (A) What are the sources of biodegradable and nonbiodegradable organics in water? Explain CBOD and NBOD with a neat sketch. Derive the mathematical formula $y_t = L_o (1 - e^{-kt})$. 6
- (B) Calculate the Theoretical Oxygen Demand (ThOD) for sugar $C_{12} H_{22} O_{11}$ dissolved in water to a concentration of 100 mg/L. Also, calculate "TOC". 4
3. (A) A wastewater treatment plant consists of primary treatment followed by an activated sludge secondary system. Sludges from the primary clarifier and waste-activated sludge from the underflow are mixed and thickened in a gravity thickener. The primary sludge contains 1,250 kg of dry solids per day with a solids content of 4 percent. content. The waste-activated sludge contains 525 kg of dry solids per day and has a solids content of 1.2 percent. After thickening, the mixture has a solids content of 3.0 percent. Calculate (a) the volume of sludge that must be processed after thickening and (b) the percent volume reduction in the thickener. 7
- (B) A wastewater plant in a coastal area faces high salinity in the sludge. Discuss how this affects digestion efficiency and land application potential. 3

PART- B

(Answer any two questions)

4. (A) State the important functions of a sanitation system, Compare the suitability of on-site and off-site sanitation systems. 4
- (B) Design a septic tank for a family of 10 persons with a desludging interval of 5 years. The average wastewater flow is 15 litres per capita per day. Also design the soak pit for the disposal of the septic tank effluent. The soil is silty loam with a long-term infiltration rate of 20 l/m²-day. 6
5. (A) A settling column analysis is run on a type-1 suspension. The settling column is 2 m deep, and the initial concentration of the well-mixed sample is 650 mg/L. Results of the analysis are shown below. 10
- | | | | | | | | |
|-----------------------|-----|-----|-----|-----|-----|-----|-----|
| Time, min | 0 | 58 | 77 | 91 | 114 | 154 | 250 |
| Conc. remaining, mg/L | 650 | 560 | 415 | 325 | 215 | 130 | 52 |
- What will be the theoretical removal efficiency in a settling basin with a loading rate of 25 m³/m²-d (25 m/d)?
6. (A) Develop a well-labeled schematic diagram illustrating the principal components of a septic tank system. Clearly indicate the positions of the inlet and outlet structures, and provide a detailed explanation of how their design and placement can affect the overall performance and operational efficiency of the septic tank. 5
- (B) A commercial area produces wastewater with variable flow throughout the day. Propose a method to measure and record flow fluctuations, and explain how this information can be used in sewer design and treatment plant sizing. 5

Sylhet Engineering College, Sylhet
(Shahjalal University of Science and Technology)
Department of Civil Engineering

Final Examination, 2025
Course No.: CE 717
Time: 02 (Two) hours

4th Year 1st Semester
Course Title: Steel Structure
Full Marks: 40

N.B: (i) Answer any two questions from each part, (ii) Use a separate answer script for each part, (iii) Marks allotted are indicated in the margin, (iv) Assume data if necessary.

Part- A

(Answer any two questions)

1. (a) State the differences between net section and gross section. 3
- (b) What is a shear lag? What are the procedures to reduce its effect? 3
- (c) Enumerate your ideas on whether a given section is compact or non-compact, providing suitable mathematical explanations and notations. 4

2. (a) Explain the local stability of a steel member. 2
- (b) For the Fig. 2.1, compute the design strength. Material type: A36 steel.
 Bolt diameter: $\frac{7}{8}$ inch (standard bolt) 8

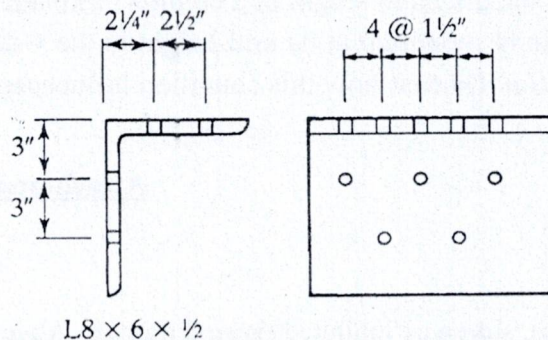

Fig. 2.1

3. (a) Illustrate different types of welds according to their position. 2
- (b) Find out the capacity of the connection as shown in the fig. 3.1, considering E70XX weld and A-36 base metal. 6

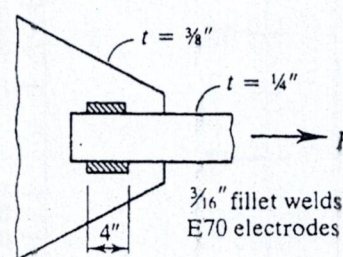

Fig. 3.1

- (c) What are the basic differences between a slot weld and a plug weld? 2

Part B

(Answer any two questions)

4. (a) What are the assumptions made for designing riveted joint? 2
- (b) How angle sections are eccentrically loaded through gusset plate? 2
- (c) What are the assumptions made for arrangement of live load in the analysis of frames? 2
- (d) Design a purlin for a roof truss having the following data: 4
 Span of the truss = 6.0 m, spacing of truss = 3m c/c, inclination of roof = 30° , spacing of purlin = 2m c/c, wind pressure = 1.5 kN/m². Roof coverage = A.C sheeting weighting 200 N/m². Provide a channel section purlin.

5. (a) Determine the plastic section modulus S and the plastic moment for the following Fig.5.1. For Grade 50 steel.

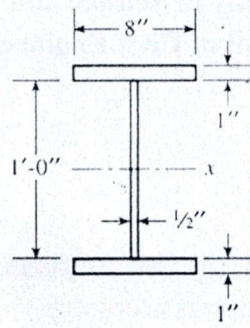

Fig. 5.1

- (b) Although Euler's formula provides the theoretical critical buckling load for columns, it is rarely used directly in modern design. Explain why this is the case, highlighting its practical limitations and modern alternatives. 2
6. (a) If a compression member is subjected to a service load of 165 kips dead load and 535 kips live load. For a member of 26 feet in length and pinned at both ends, choose a suitable section of A992 steel of W14 shape. 7
- (b) What is the effective length of a column? Explain how the effective length changes when a column is supported at its mid-height in the x-direction but remains unsupported in the y-direction. Discuss how this condition influences the design strength of the column. 3

Attachments

Alignment chart, sidesway inhibited (braced frame) Alignment chart, sidesway uninhibited (moment frame)

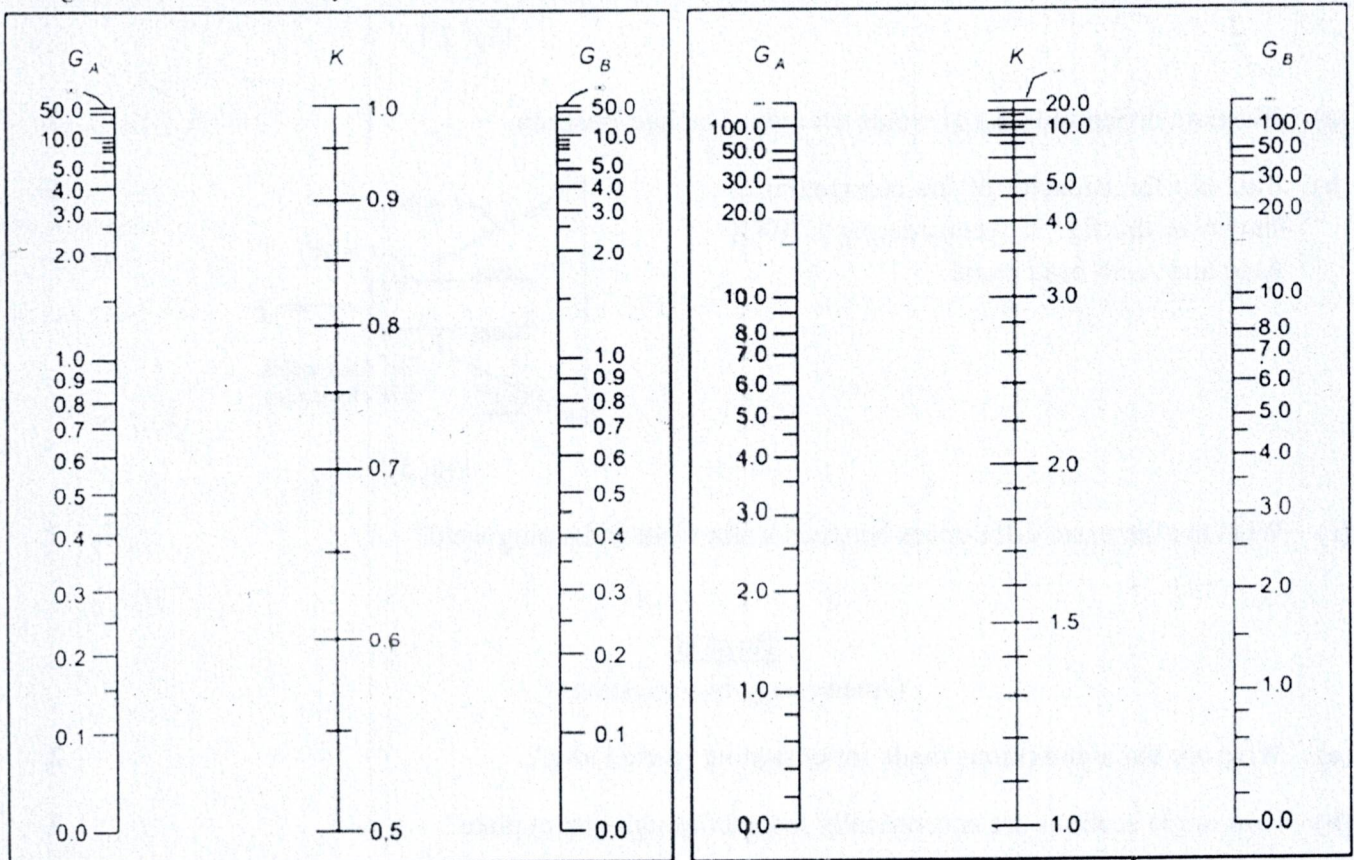



Fig. A.1

Shape	Area (in ²)	Depth (in)	Width (in)	Section Properties	
				I _x (in ⁴)	I _y (in ⁴)
W12x79 Dimensions	23.2	12.4	12.1	662	216
W12x87 Dimensions	25.6	12.5	12.1	740	241
W12x96 Dimensions	28.2	12.7	12.2	833	270
W12x106 Dimension	31.2	12.9	12.2	933	301
W12x120 Dimension	35.2	13.1	12.3	1070	345
W12x136 Dimension	39.9	13.4	12.4	1240	398
W21x275 Dimension	81.8	24.1	12.9	7690	787
W24x55 Dimensions	16.2	23.6	7.01	1350	29.1
W24x62 Dimensions	18.2	23.7	7.04	1550	34.5
W24x68 Dimensions	20.1	23.7	8.97	1830	70.4
W24x76 Dimensions	22.4	23.9	8.99	2100	82.5
W24x84 Dimensions	24.7	24.1	9.02	2370	94.4
W24x94 Dimensions	27.7	24.3	9.07	2700	109
W24x103 Dimension	30.3	24.5	9	3000	119
W24x104 Dimension	30.7	24.1	12.8	3100	259
W24x117 Dimension	34.4	24.3	12.8	3540	297
W24x131 Dimension	38.6	24.5	12.9	4020	340
W24x146 Dimension	43	24.7	12.9	4580	391
W24x162 Dimension	47.8	25	13	5170	443
W24x176 Dimension	51.7	25.2	12.9	5680	479
W24x192 Dimension	56.5	25.5	13	6260	530
W24x207 Dimension	60.7	25.7	13	6820	578
W24x229 Dimension	67.2	26	13.1	7650	651
W24x250 Dimension	73.5	26.3	13.2	8490	724
W24x279 Dimension	81.9	26.7	13.3	9600	823

Fig. A.2

Table 4-1 (continued)
Available Strength in Axial Compression, kips
W-Shapes

$F_y = 50 \text{ ksi}$



W14

Shape	lb/ft	W14											
		145		132		120		109		99		90	
		P_n/Ω_c	$\phi_c P_n$	P_n/Ω_c	$\phi_c P_n$	P_n/Ω_c	$\phi_c P_n$	P_n/Ω_c	$\phi_c P_n$	P_n/Ω_c	$\phi_c P_n$	P_n/Ω_c	$\phi_c P_n$
Length, K_L (ft), with respect to least radius of gyration, r_y	Design	ASD	LRFD	ASD	LRFD	ASD	LRFD	ASD	LRFD	ASD	LRFD	ASD	LRFD
	0	1280	1920	1160	1750	1060	1590	958	1440	871	1310	793	1190
	6	1250	1880	1130	1700	1030	1550	932	1400	848	1270	772	1160
	7	1240	1860	1120	1680	1020	1530	923	1390	839	1260	764	1150
	8	1230	1840	1110	1660	1010	1510	913	1370	830	1250	755	1140
	9	1210	1820	1090	1640	994	1490	901	1350	819	1230	745	1120
	10	1200	1800	1080	1620	980	1470	888	1340	807	1210	735	1100
	11	1180	1770	1060	1600	965	1450	874	1310	794	1190	723	1090
	12	1160	1750	1040	1570	948	1430	859	1290	780	1170	710	1070
	13	1140	1720	1020	1540	931	1400	843	1270	766	1150	697	1050
	14	1120	1690	1000	1510	912	1370	826	1240	750	1130	682	1030
	15	1100	1650	982	1480	892	1340	808	1210	733	1100	667	1000
	16	1080	1620	960	1440	872	1310	789	1190	716	1080	652	979
	17	1060	1590	937	1410	850	1280	770	1160	698	1050	635	955
	18	1030	1550	913	1370	828	1240	750	1130	680	1020	618	929
	19	1010	1510	888	1330	805	1210	729	1100	661	994	601	903
	20	980	1470	862	1300	782	1180	708	1060	642	964	583	877
	22	927	1390	810	1220	734	1100	664	998	602	904	547	822
	24	872	1310	756	1140	685	1030	620	931	561	843	509	766
	26	816	1230	702	1060	635	955	574	863	519	781	472	709
28	759	1140	648	974	586	880	529	796	478	719	434	653	
30	703	1060	594	893	537	807	485	729	438	658	397	597	

Fig. A.3

Minimum Size of Fillet Welds

Material Thickness of Thinner Part Joined, in. (mm)	Minimum Size of Fillet Weld, ^[a] in. (mm)
To 1/4 (6) inclusive	1/8 (3)
Over 1/4 (6) to 1/2 (13)	3/16 (5)
Over 1/2 (13) to 3/4 (19)	1/4 (6)
Over 3/4 (19)	5/16 (8)

^[a] Leg dimension of fillet welds. Single pass welds must be used.
Note: See Section J2.2b for maximum size of fillet welds.

Fig. A.4

Sylhet Engineering College, Sylhet
(Shahjalal University of Science and Technology)
Department of Civil Engineering

Final Examination, 2024
Course No.: CE 715
Time: 02 (Two) hours

4th Year 1st Semester
Course Title: Structural Analysis III
Full Marks: 40

N.B: (i) Answer any two questions from each part, (ii) Use a separate answer script for each part, (iii) Marks allotted are indicated in the margin, (iv) Assume data if necessary.

Part- A

(Answer any two questions)

1. (a) Discuss the differences between a conjugate beam and a real beam with suitable sketches. 3
- (b) Find the reactions of the following fig. 1.1, using the force method. Draw the SFD and BMD 7

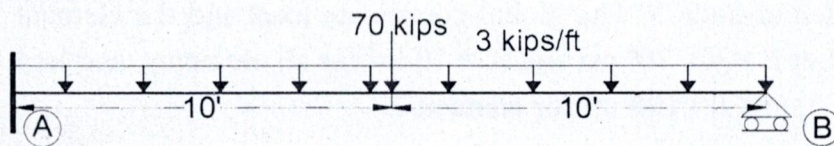

Fig. 1.1

2. (a) What is a shape function, and how does it explain the changes in variables such as displacement within an element? Discuss with mathematical explanations. 7
- (b) Discuss the general steps of the Finite Element method with proper mathematical expressions. 3

3. (a) Obtain the displacement at node 2 and F_{5x} for Fig. 3.1. At node 5, the known displacement (δ) is 20 mm, and the spring constant is = 200 KN/m 7

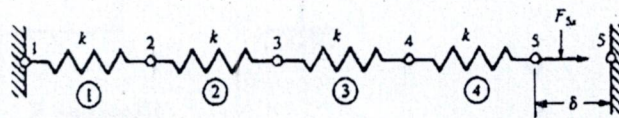

Fig. 3.1

- (b) For an element shown in Fig. 3.2, discuss where nodes should be placed with an appropriate explanation. 3

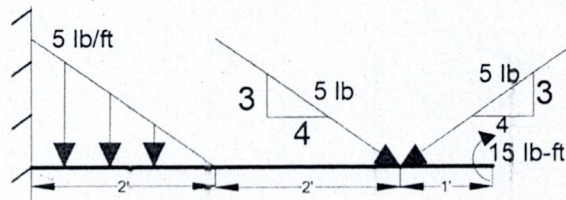

Fig. 3.2

Part B

(Answer any two questions)

4. (a) Using the potential energy approach, obtain the global matrix for Fig. 4.1. 8

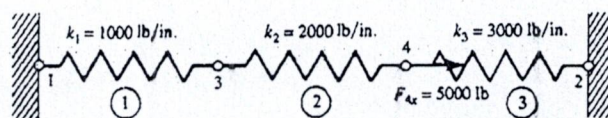

Fig. 4.1

- (b) To derive the finite element equation, the principle of "Minimum Potential Energy" is applied. Explain the reasons for using this principle, supporting your answer with suitable sketches. 2

5. Find the stresses for each of the elements in Fig. 5.1. The modulus of elasticity is 30×10^6 psi, and the area is 2 in^2 for all elements. 10

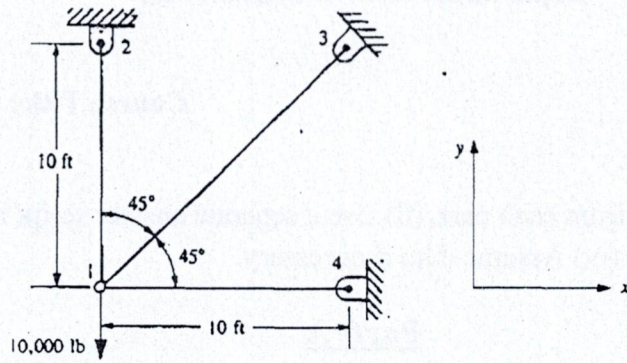

Fig. 5.1

6. Solve the rigid plane frame shown in Fig:-5. The frame is fixed at nodes 1 and 4 and subjected to a positive horizontal force of 10,000 lb applied at node 2 and to a positive moment of 5000 lb-in. applied at node 3. The global-coordinate axes and the element lengths are shown in Fig:-5. Let $E = 30 \times 10^6$ psi and $A = 10 \text{ in}^2$ for all elements, and let $I = 200 \text{ in}^4$ for elements 1 and 3, and $I = 100 \text{ in}^4$ for element 2. 10

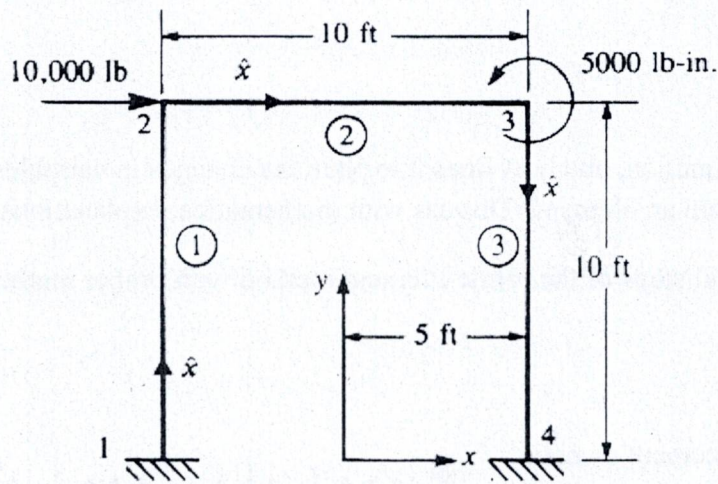

Figure: 5