

N.B. : (i) Answer any three questions from each PART

(ii) Use separate answer scripts for each PART

(iii) Marks allotted are indicated in the margin

(iv) Special Instruction (if any)-----N/A-----

**PART- A**

(Answer any three questions)

1. (a) Define stress and strain. Describe briefly the stress-strain diagram. 2.5  
 (b) A composite bar consists of four sections rigidly fastened as shown in Figure-1 Axial loads are applied at the positions indicated. Determine the stress in each section. 7.5

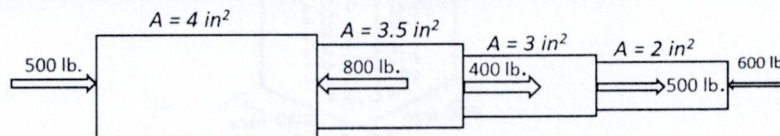

Figure-1

2. (a) Without writing shear and moment equations, draw the shear and moment diagrams for the beam specified shown in Figure-2. Give numerical values at all changes of loading positions and all points of zero shear. 05

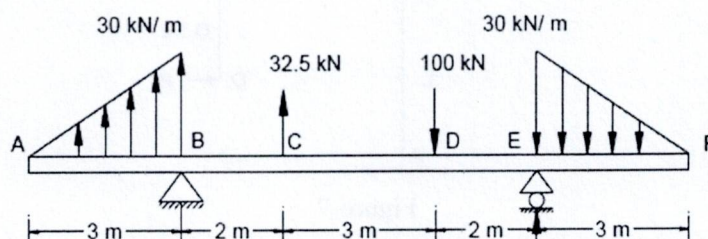

Figure-2

- (b) Draw the moment and load diagrams corresponding to the given shear diagram shown in Figure-3. Specify values at all changes of load positions and all points of zero shear. 05

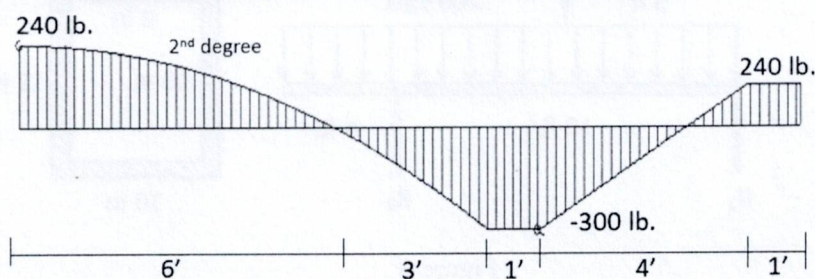
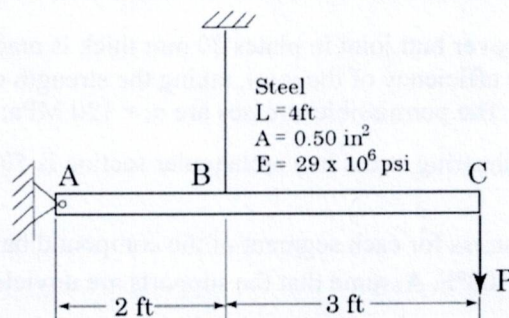

Figure-3

3. (a) The rigid bar ABC shown in fig is hinged at A and supported by a steel rod at B. determine the largest load P that can be applied at C if the stress in the steel rod is limited to 30 ksi and the vertical movement of C must not exceed 0.10 in. 06



- (b) Define Poisson's ratio. Show that theoretically the Poisson's ratio of any materials  $\nu \leq 0.50$  04

4. (a) A solid aluminum shaft of 80 mm diameter fits concentrically in a hollow steel tube. Compute the minimum internal diameter of the steel tube so that no contact pressure exists when the aluminum shaft carries an axial compressive toad of 400 kN. Assume  $\nu = 1/3$  and  $E_{al} = 70$  GPa. 04

- (b) Draw shear force and bending moment diagram for the beam shown in fig- 06

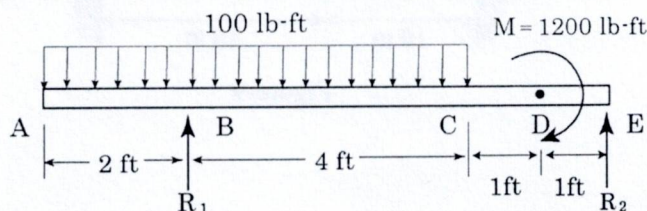

## PART- B

(Answer any three questions)

5. (a) The short concrete post in Figure-6 is reinforced with six symmetrically placed steel bars, each 500 mm<sup>2</sup> in area. If the load  $P$  is 1000 kN, compute the stress developed in each material. Moduli of elasticity for steel and concrete are 200 GPa and 14 GPa respectively. 5.5

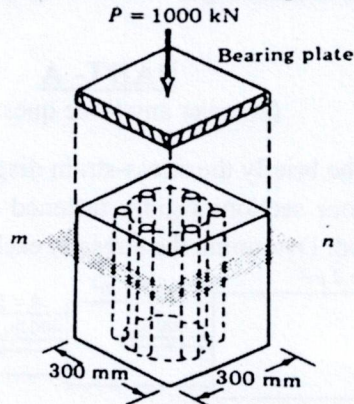

Figure-6

- (b) A frame with rigid corners at B and C, supports the concentrated load as shown in Figure-7. Draw the shear and moment diagrams for each of the three parts of the frame. 4.5

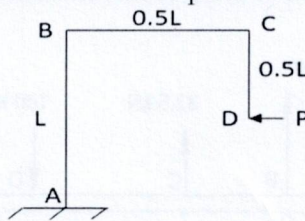

Figure-7

6. (a) A box beam carries a distributed load of 200 lb/ft and a concentrated load  $P$  as shown in Figure-8. Determine the maximum value of  $P$  if  $\sigma_f \leq 1200$  psi and  $\tau \leq 150$  psi. 10

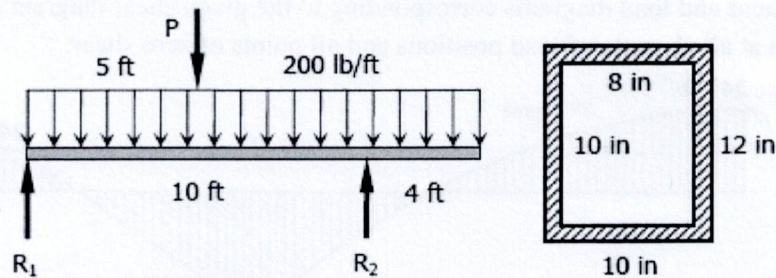

Figure-8

7. (a) A 200 X 100 X 20 mm angle is to be welded to a gusset plate with the 200 mm leg against the plate. If the angle carries a centroidal load of 400 kN, what lengths of 8-mm side fillet welds will be required along the toe and heel of the angle for a concentric connection? Assume the allowable shearing stress through the throats of the welds is 145 MPa. 06
- (b) A double riveted double cover butt joint in plates 20 mm thick is made with 25 mm diameter rivets at 100 mm pitch. Find the efficiency of the joint, taking the strength of the rivet in double shear as twice that of single shear. The permissible stresses are  $\sigma_t = 120$  MPa;  $\tau = 100$  MPa;  $\sigma_c = 150$  MPa. 04
8. (a) Show that the maximum shearing stress in a rectangular section is 50% greater than the average shearing stress. 03
- (b) Calculate the increase in stress for each segment of the compound bar shown in Figure-9 if the temperature increases by 100°F. Assume that the supports are unyielding and that the bar is suitably braced against buckling. 07

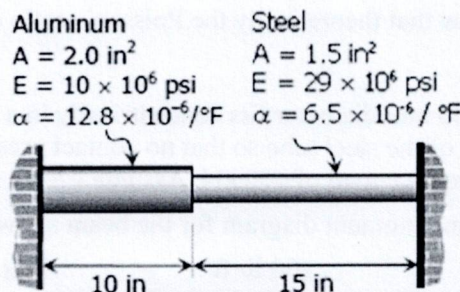

Figure-9

**Sylhet Engineering College, Sylhet**  
**(Shahjalal University of Science & Technology)**

**Department of Civil Engineering**

**Final Examination, 2023**

**Course No.: CE 307**

**Time: 03 (Three) hours**

**2<sup>nd</sup> Year 1<sup>st</sup> Semester**

**Course Title: Engineering Materials**

**Full Marks: 60**

N.B. : (i) Answer any three question from each PART

(ii) Use separate answer scripts for each PART

(iii) Marks allotted are indicated in the margin

(iv) Special Instruction (if any)-----N/A-----

**PART- A**

(Answer any three questions)

1. a. What is Engineering Material? Discuss the mechanical Properties of engineering materials. **03**  
b. What are the main ingredients of brick clay? Discuss their functions in bricks. **03**  
c. What are the characteristics of good bricks? How will you conduct the quality of a brick in the field? **04**
2. a. Write down the Mineral Constituents of Portland Cement with Percentage? **05**  
b. Discuss the slump test method for workability of concrete. **05**
3. a. Why gypsum is used in cement? What do you mean by normal consistency of cement? Discuss the setting time of cement. What are the impurities of brick clay? **04**  
b. Design a concrete mix for the following data: Fineness modulus of fine aggregate=2.88, Fineness modulus of coarse aggregate=6.28, The combined fineness modulus is 5.18, Shrinkage factor= 0.75, The volume of the compacted aggregate is 3.76 cft for one cft of cement. The bulking of fine aggregate for 5% moisture is 29.5% and that of the coarse aggregate for 3% moisture is 6%. Determine the mixing ratio of Cement: F.A: C.A. **06**
4. a. What is sand? Discuss the types of sand. What is the function of sand in concrete? **03**  
b. Discuss the properties of plastics. **03**  
c. Differentiate between fineness modulus (F.M.) and grading of an aggregate mix. Find the F.M. of a sand sample from the following sieve analysis results. **04**

Sieve size, mm	4.75	2.36	1.40	1.18	0.60	0.30	0.15	0.075	PAN
Amount Retained, grn	10.0	13.7	50.0	75.1	90.9	50.1	40.2	16.9	3.1

**PART- B**

(Answer any three questions)

5. a. What is ferrocement? Write down the advantage and disadvantage of ferrocement. **03**  
b. Discuss prestressed concrete, shrinkage of concrete, shuttering. **02**  
c. Two samples of sand one from Dhaka (F.M of 2.66) and others from Khulna (F.M of 2.25) were mixed together to get a Combined F.M of 2.45. Determine the ratio in which they were mixed. **05**
6. a. Write down the objectives of seasoning of timber. **04**  
b. Write down the conversion of felled timber trees. **04**  
c. Write different types of defects in timber. **02**
7. a. What is curing? Discuss various method of curing using in concrete. **03**  
b. What is rubber and discuss types of rubber. **03**  
c. Short note the following terms: **04**  
i) Color washing  
ii) Paint  
iii) Varnish.
8. a. Why bleeding and honeycomb arise during casting of concrete? How can you minimize such type of concrete. **03**  
b. What is meant by the term of creep of concrete? Explain briefly the factors influencing creep in concrete. **04**  
c. Define the admixture? What is the reason for the using of admixture in concrete? **03**

**Sylhet Engineering College, Sylhet**  
**(Shahjalal University of Science & Technology)**  
**Department of Civil Engineering**

**Final Examination, 2023**

**Course No.: CE 309**

**Time: 02 (Two) hours**

**2<sup>nd</sup> Year 1<sup>st</sup> Semester**

**Course Title: Numerical Analysis**

**Full Marks: 40**

- N.B. : (i) Answer any two question from each PART (ii) Use separate answer scripts for each PART  
 (iii) Marks allotted are indicated in the margin (iv) Special Instruction (if any)-----N/A-----

**PART- A**

(Answer any two questions)

1. (a) If you had to find the root of a nonlinear equation that models the load-displacement behavior of a structural element, which method would you prefer: the **Newton-Raphson** method or the **Bisection** method? Justify your choice. 3
- (b) A civil engineering team is working on a project to design three different types of concrete mixtures for constructing a building foundation. The total weight of the materials used in the three mixtures must meet specific requirements to ensure strength and stability. The first mixture uses a combination of cement, sand, and gravel, and the total weight of these materials is 7 tons. For the second mixture, the amount of cement remains the same, but double the amounts of sand and gravel are used, resulting in a total weight of 13 tons. For the third mixture, the amount of sand is tripled while keeping the amount of cement and gravel the same as in the first mixture, resulting in a total weight of 13 tons. Using the Gauss-Seidel method, determine how many tons of cement, sand, and gravel are used in the first mixture to meet the specified weights for each mixture. 7

2. (a) Fit a second-degree parabola to the following data using the method of **least squares** 5

X	0	1	2	3	4
Y	1	1.8	1.3	2.5	6.3

- (b) Solve the system of equations,  $8x - 3y + 2z = 20$ ,  $6x + 3y + 12z = 35$  and  $4x + 11y - z = 33$  by Jacobi iteration method. 5

3. (a) A four-story building is shown in the figure below, where the height of each story is 3 meters. The equivalent earthquake forces at three of the four stories are also provided in the figure. Using the Lagrange Interpolation Formula, calculate the equivalent earthquake force at the second story. 6

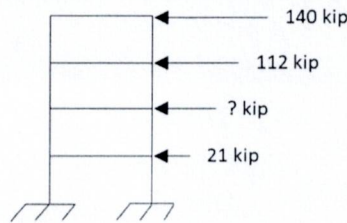

- (b) For the following data, which formula is suitable to find the derivative of  $f(x)$  at the point  $x = 1.5$ ? Find the first and second derivatives. 4

$x$	1.5	2.0	2.5	3.0	3.5	4.0
$f(x)$	3.375	7.000	13.625	24.000	38.875	59.000

**PART- B**

(Answer any two questions)

4. (a) Explain Euler's method. Why Euler's method is the numerical solution for differential equations? 2
- (b) Find a root of an equation  $f(x)=2x^3-2x-5$  correct to three decimals using the Bisection method 4
- (c) Solve  $x^3 + 2x^2 + 10x = 20$  by Newton-Raphson method. Correct to four decimal places. 4
5. (a) Evaluate  $\int_0^{10} \frac{dx}{4+x^2}$  by using 6  
 (i) **Trapezoidal** rule, (ii) **Simpson's 1/3** rule, and (iii) Compare the results with the actual value.
- (b) Using **Taylor's** series method solve  $y' = xy + y^2$ ,  $y(0) = 1$  at  $x = 0.1$  and  $0.2$ . 4
6. (a) Using the second-order **Runge-Kutta** method, find  $y$  at  $x = 0.1$  and  $0.2$  for  $2y' = (1+x)y^2$ ;  $y(0) = 1$ . 5
- (b) Solve  $\frac{dy}{dx} = y - \frac{2x}{y}$ ;  $y(0) = 1$  in the range  $0 \leq x \leq 0.2$  by using (i) Euler's method and (iii) modified Euler's method. Take  $h = 0.1$  5

**Sylhet Engineering College, Sylhet**  
**(Shahjalal University of Science & Technology)**  
**Department of Civil Engineering**

Final Examination, 2023

2<sup>nd</sup> Year 1<sup>st</sup> Semester

Course No.: CSE 311/CSE 411

Course Title: Introduction to Computer Language

Time: 02 (Two) hours

Full Marks: 40

N.B. : (i) Answer any two question from each PART

(ii) Use separate answer scripts for each PART

(iii) Marks allotted are indicated in the margin

(iv) Special Instruction (if any)-----N/A-----

**PART- A**

(Answer any two questions)

1. (a) Where was C originally developed and by whom? 1  
(b) Name some commonly used high-level languages. What are the advantages of using high-level languages? 3  
(c) Name and describe with example the four basic data types in C. 3  
(d) Write C assignment statements to evaluate the following equations. 3  
i)  $A = \pi r^2$       ii)  $x = \frac{-b \pm \sqrt{b^2 - 4ac}}{2a}$       iii)  $V = \frac{4}{3} \pi r^3$
2. (a) What are the keywords in C? Summarize the rules for naming identifiers in C. 4  
(b) Define the term “pseudocode”. Convert the pseudocode below to a flowchart. 3  
Begin  
Set i=0  
Set sum=0  
While i<10  
Get x  
Sum=sum+x  
Add 1 to i  
Avg= sum/10.0  
Print avg  
End  
(c) What will be the output of the following C code? 3  

```
int i,j,k;
for(i=0,j=0,k=0;i<2,k<6,j<8;i++)
{
    printf("%d %d %d\n", i, j, k);
    j+=2;
    k+=3;
}
```
3. (a) What is the syntax of ‘for’ loop in C? Give an example nested loop. 2  
(b) Distinguish between “++C” and “C++” in C. Write an example of an infinite loop using any loop in C. 3  
(c) You are given a non-negative floating-point number rounded to two decimal places celsius, that denotes the temperature in Celsius. 5  
You should write a program to convert Celsius into Kelvin and Fahrenheit and return it as an array ans = [kelvin, fahrenheit].  
Note that:  
  - Kelvin = Celsius + 273.15
  - Fahrenheit = Celsius \* 1.80 + 32.00  
Example 1:  
Input: celsius = 36.50  
Output: [309.65, 97.70]  
Explanation: Temperature at 36.50 Celsius converted in Kelvin is 309.65 and converted in Fahrenheit is 97.70.  
Example 2:  
Input: celsius = 122.11  
Output: [395.26, 251.79]  
Explanation: Temperature at 122.11 Celsius converted in Kelvin is 395.26 and converted in Fahrenheit is 251.79.  
  
Constraints:  
  - 0 <= celsius <= 1000

**PART- B**

(Answer any two questions)

4. (a) When do we use the following statement?  
for( ; ; ) 2

(b) Find errors, if any, in each of the following segments: 3

- i. if (x+y = z && y>0)  
printf(“ “);
- ii. if (code > 1);  
a=b+c  
else  
a=0
- iii. if (p<0) || (q<0)  
printf(“sign is negative”);

2+3

(c) What are storage classes? What is the difference between Local & Global Variable? Give Example.

5. (a) What is a pointer in C programming? List three advantages of assembly language over a high level language. 3

(b) What is a global variable? Differentiate between a variable and a constant. 3

(c) How to declare an array? Write the program's output that follows. 4

```
int i, x=10;
for(i=0; i<10; i++)
{
    if(i%2==1)
        x=x+i;
    else
        x--;
    printf("%d\n",x);
}
```

6. (a) Write some applications of C programming language in the field of Civil Engineering. 2

(b) Discuss the evolution of computer technology across the different generations. Provide examples to illustrate how computer technology has changed over the years. 4

(c) A *perfect number* is a positive integer that is equal to the sum of its positive divisors, excluding the number itself. A divisor of an integer x is an integer that can divide x evenly. Given an integer n, write a program to check whether the number is a perfect, return true if n is a perfect number, otherwise return false. 4

Example 1:

Input: num = 28

Output: true

Explanation: 28 = 1 + 2 + 4 + 7 + 14

1, 2, 4, 7, and 14 are all divisors of 28.

Example 2:

Input: num = 7

Output: false

Constraints:

- 1 <= num <= 10<sup>8</sup>

# Sylhet Engineering College

Department of Civil Engineering

BSc. Program (2/1) Session: 2021-22

Course Code: SS 301 Course Title: Accounting

Semester Final Examination 2023

Total Marks: 40

Time: 02 Hours

[Answer any four (04) questions from the followings including 02 from each part.  
Figures in the margin indicate full marks. All the parts of a question must be answered chronologically.]

## Part-“A”

01. (a) “Accounting is ingrained in our society and it is vital to our economic system.” Do you agree? Explain. 2
- (b) Give a brief description of the major functions of Accounting. 2
- (c) Can a business enter into a transaction in which only the left side of the basic accounting equation is affected? If so, give an example. 2
- (d) “A company’s net income appears directly on the income statement and the owner’s equity statement, and it is included indirectly in the company’s balance sheet.” Do you agree? Explain. 2
- (e) Distinguish between Financial Accounting & Management Accounting. 2
02. (a) Define the terms assets, liabilities, and owner’s equity. 2
- (d) Threet’s Repair Shop was started on May 1 by Erica Threet. A summary of May transactions is presented below. Prepare an Accounting Equation: 8
1. Invested \$10,000 cash to start the repair shop.
  2. Purchased equipment for \$5,000 cash.
  3. Paid \$400 cash for May office rent.
  4. Paid \$500 cash for supplies.
  5. Incurred \$250 of advertising costs in the *Beacon News* on account.
  6. Received \$6,100 in cash from customers for repair service.
  7. Withdrew \$1,000 cash for personal use.
  8. Paid part-time employee salaries \$2,000.
  9. Paid utility bills \$170.
  10. Provided repair service on account to customers \$750.
  11. Collected cash of \$120 for services billed in transaction (10).

ASSETS					=	Liabilities + Owner’s Equity	
T.	Cash	Accounts	Supplies	Equipment	=	Accounts	E.Threet.
N.		Receivable				Payable	Capital

03. (a) Identify the basic steps in the recording process. 2
- (b) Frontier Park was started on April 1 by H. Hillenmeyer. The following selected events and transactions occurred during April. 8
- Apr. 1 Hillenmeyer invested \$35,000 cash in the business.
  - 4 Purchased land costing \$27,000 for cash.
  - 8 Incurred advertising expense of \$1,800 on account.
  - 11 Paid salaries to employees \$1,500.
  - 12 Hired park manager at a salary of \$4,000 per month, effective May 1.
  - 13 Paid \$1,650 cash for a one-year insurance policy.
  - 17 Withdrew \$1,000 cash for personal use.
  - 20 Received \$6,800 in cash for admission fees.
  - 25 Sold 100 coupon books for \$25 each. Each book contains 10 coupons that entitle the holder to one admission to the park.
  - 30 Received \$8,900 in cash admission fees.
  - 30 Paid \$900 on balance owed for advertising incurred on April 8.

Hillenmeyer uses the following accounts: Cash, Prepaid Insurance, Land, Accounts Payable, Unearned Service Revenue, Owner’s Capital, Owner’s Drawings, Service Revenue, Advertising Expense, and Salaries and Wages Expense.

**Instruction:**

Journalize the April transactions.

## Part-“B”

- 04 (a) What is the difference between transaction and event? 2  
 (b) Mohit has the following transactions, prepare the accounting equation with description: 8
- a. Business started with cash tk 1,75,000
  - b. Purchased goods from Rohit tk 50,000
  - c. Sold goods on credit to Manish (Costing tk 17,500) tk 20,000
  - d. Purchased furniture for office use tk 10,000
  - e. Cash paid to Rohit in full settlement tk 48,500
  - f. Cash received from Manish tk 20,000
  - g. Rent Paid tk 1,000
  - h. Cash withdrew for personal use tk 3,000

05. (a) What are the steps in Accounting cycle as per modern school of thought? 2  
 (b) **Shany's Advertising Agency**  
**Trial Balance**  
**October 31, 2017** 8

Sl. #	Particulars	L. F.	Debit (\$)	Credit (\$)
01.	Cash		50,000/=	
02.	Advertising Supplies		2,500/=	
03.	Prepaid Insurance		500/=	
04.	Office Equipment		5,000/=	
05.	Notes Payable			5,000/=
06.	Accounts Payable			2,500/=
07.	Unearned Revenue			1,200/=
08.	C. R. Byrd, Capital			10,000/=
09.	C. R. Byrd, Drawings		1,000/=	
10.	Service Revenue			47,300/=
11.	Salaries expense		4,000/=	
12.	Rent Expense		3,000/=	
	<b>Total</b>		<b>\$ 66,000/=</b>	<b>\$ 66,000/=</b>

At 31<sup>st</sup> October, assume the following data:

- (i) Advertising supplies on hand at October 31<sup>st</sup>, total \$ 1,400/=.
- (ii) Expired insurance for the month is \$ 100/=.
- (iii) Depreciation for the month is \$ 50/=.
- (iv) Unearned revenue in October totals \$ 600/=.
- (v) Services provided but unbilled at October 31<sup>st</sup> are \$ 300/=.
- (vi) Interest accrued at October 31<sup>st</sup> is \$ 70/=.
- (vii) Accrued salaries at October 31<sup>st</sup> are \$ 1,500/=.

**Required:** Prepare a 10 (ten) column work sheet.

06. (a) **Write Short Notes:** 2x3= 6
- (i) Business Enterprises
  - (ii) Accounting Concepts and Conventions
  - (iii) Double-Entry System
- (b) How does managerial accounting differ from financial accounting? What is the importance of the Generally Accepted Accounting Principles (GAAP)? 4

**Sylhet Engineering College, Sylhet**  
**(Shahjalal University of Science & Technology)**  
**Department of Civil Engineering**

**Final Examination, 2023**  
**Course No.: MATH 303**

**2<sup>nd</sup> Year 1<sup>st</sup> Semester**  
**Course Title: Vector Analysis, Laplace Transform, Fourier**  
**Analysis & Harmonic Functions**

**Time: 03 (Three) hours**

**Full Marks: 60**

N.B. : (i) Answer any three questions from each PART

(ii) Use separate answer scripts for each PART

(iii) Marks allotted are indicated in the margin

(iv) Special Instruction (if any)-----N/A-----

**PART- A**

(Answer any three questions)

1. (a) Define with examples: i) Fourier series ii) Even and odd functions 03
- (b) Determine whether the vectors  $\vec{A}=\hat{i}-3\hat{j}+2\hat{k}$ ,  $\vec{B}=2\hat{i}-4\hat{j}-\hat{k}$ ,  $\vec{C}=3\hat{i}+2\hat{j}-\hat{k}$  are linearly independent or linearly dependent. 04
- (c) Find the volume and draw graph of the parallelepiped whose edges are represented by the vectors  $\vec{A}=2\hat{i}-3\hat{j}+4\hat{k}$ ,  $\vec{B}=\hat{i}+2\hat{j}-\hat{k}$  and  $\vec{C}=3\hat{i}-z\hat{j}+2\hat{k}$ . 03
2. (a) Determine the constant "a" so that the vector  $\vec{V}=(x+3y)\hat{i}+(y-2z)\hat{j}+(x+az)\hat{k}$  is solenoidal 02
- (b) Show that  $\vec{\nabla}r^n=nr^{n-2}\vec{r}$  04
- (c) Suppose  $\vec{A}=2yz\hat{i}-x^2y\hat{j}+xz^2\hat{k}$ ,  $\vec{B}=x^2\hat{i}+yz\hat{j}-xy\hat{k}$  and  $\phi=2x^2yz^3$ . Find (a)  $(\vec{A}\cdot\vec{\nabla})\phi$  (b)  $(\vec{A}\times\vec{\nabla})\phi$  04
3. (a) Suppose  $\phi=2xyz^2$ ,  $\vec{F}=xy\hat{i}-z\hat{j}+x^2\hat{k}$  and C is the curve  $x=t^2$ ,  $y=2t$ ,  $z=t^3$  from  $t=0$  to  $t=1$ . Evaluate the line integral (a)  $\int_C \phi dr$  (b)  $\int_C \vec{F} \times dr$  05
- (b) Evaluate  $\iint_S \vec{A}\cdot\hat{n} ds$ , where  $\vec{A}=18z\hat{i}-12\hat{j}+3y\hat{k}$  and S is that part of the plane  $2x+3y+6z=12$ , which is located in the first octant. 05
4. (a) State and prove Green's theorem. 05
- (b) Verify stoke's theorem for  $\vec{A}=(y-z+2)\hat{i}+(yz+4)\hat{j}-xz\hat{k}$ , Where S is the surface of the of the cube  $x=0$ ,  $y=0$ ,  $z=0$ ,  $x=2$ ,  $y=2$ ,  $z=2$  above the  $xy$ -plane with graph. 05

**PART- B**

(Answer any three questions)

5. (a) If  $L\{F(t)\}=f(s)$  then show that  $L\{e^{at}F(t)\}=f(s-a)$  02
- (b) Find:  $L\{t^2\sin t\}$ ,  $L\{4e^{5t}+6t^3-3\cos 4t+4\sin 5t\}$  3+2
- (c) If  $L\{F(t)\}=f(s)$ ,  $G(t)=\begin{cases} F(t-a), & t > a \\ 0, & t < a \end{cases}$ , then show that  $L\{G(t)\}=\{e^{-as}f(s)\}$  03
6. (a) Find:  $L^{-1}\left\{\frac{2s^2-6s+5}{s^3-6s^2+11s-6}\right\}$  04
- (b) Solve using Laplace Transformation:  $Y''(t)+9Y'(t)=\cos 2t$ , if  $Y(0)=1$ ,  $Y'(0)=a$  06
7. (a) Expand the function  $f(x)=x$ ,  $0 < x < 2$  in half range fourier sine series 04
- (b) Find the Fourier series of the following function 06  

$$f(x)=\begin{cases} 0, & -5 < x < 0 \\ 3, & 0 < x < 5 \end{cases}$$
8. (a) Define periodic function with example and graph 02
- (b) Write about Dirichlet's condition with graph. 03
- (c) Using sine integral formula to the function  $f(x)=\begin{cases} 1, & \text{when } 0 < x < a \\ \frac{1}{2}, & \text{when } x = a \\ 0, & x > a \end{cases}$  05  
 show that,  $f(x)=\frac{2}{\pi}\int_0^\infty \frac{(1-\cos au)\sin ux}{u} du$