

Sylhet Engineering College, Sylhet
(Shahjalal University of Science & Technology)
Department of Computer Science & Engineering

Final Examination, 2024
Course No: CSE 0613 1133
Time: 02 (Two) hours

1st Year 1st Semester
Course Title: Structured Programming Language
Full Marks: 60

N.B.: (i) Use separate answer scripts for each PART
(iii) Special Instruction (if any)-----N/A

(ii) Marks allotted are indicated in the margin

PART-A

- 1.(a) Why and when do we use **#include** and **#define** directive? 2+2
- (b) Distinguish between the following pairs: 2+2
- i. main() and void main(void)
 - ii. int main() and void main()
- (c) Find errors if any, in the following program: 2
- ```
Include(stdio.h)
void main{ }
(
 Float X;
 X=2.5;
 Y=exp(x);
 Print(x,y);
)
```
- (d) How do we implement multiple source program files? 2
- (e) Describe the structure of a C program. 3

**OR**

- 1.(a) Differentiate between local and global variable 3
- (b) Describe four basic data types. How could we extend the range of values they represent? 2+2
- (c) Which of the following are invalid variable names and why? 4
- i. Minimum
  - ii. doubles
  - iii. Sum Total
  - iv. n\$
  - v. Column-total
  - vi. &name
  - vii. n1+n2
  - viii. 3rd\_row
- (d) What would be the value of x after execution of the following statements? 2
- ```
int x,y=10;
char x= 'a';
x=y+z
```
- (e) Describe the characteristics and purpose of escape sequence characters. 2
- 2.(a) Which of the following arithmetic expressions are valid? If valid, give the value of the expression; otherwise give the reason. 2
- i. 21% (int)4.5
 - ii. 15.25+-5.0
 - iii. 14%3+7%2
 - iv. 7.5%3
- (b) Determine the value of each of the following logical expressions if a=5, b=10 and c=-6 2
- i. a>b && a<c
 - ii. a==c || b>a
 - iii. a<b && a>c
 - iv. b>15 && c<0 || a>0
- (c) Find errors, if any, in the following assignment statements and rectify them. 2
- i. x=y=z=5,4,-5;
 - ii. s=/5;
 - iii. m=++a*5;
 - iv. p*=x/y;

- (d) Find the output of the following program? 2
- ```
main()
{
 int x=50;
 printf("%d/n",5 + x++);
 printf("%d/n",5 + ++x);
}
```
- (e) What is the difference between the two statements  $a = -2$  and  $a = 2$ ? 3
- (f) Differentiate between logical operators (&&, ||, !) and bitwise operators (&, |, ^, ~). When would you use each? 4

### PART-B

- 3.(a) The following segment of a program: 1+1
- ```
m=1;
n=1;
x==1;
if (x> 0)
  m= m++;
  y= --m ;
printf(" %d %d", m, n);
What will be the values of m and n.
```
- (b) What will be the value of x when the following segment is executed? 2
- ```
int x=10, y=15;
x= (x<y)? (y+x) : (y-x);
```
- (c) What will be the output when the following segment is executed? 2
- ```
int x=0;
if (x>=0)
if (x>0)
  printf("Number is positive");
else
  printf("Number is negative");
```
- (d) What is null statements? How can we use for loops when the number of iterations are not known? 1+2
- (e) Compare, in terms of their functions, the following pairs of statements: 3X2
- i. while and do...while
 - ii. break and goto
 - iii. break and continue

OR

- 3.(a) What happens when an array with a specified size is assigned? 2
- i. with values fewer than the specified size; and
 - ii. with values more than the specified size.
- (b) Change the following for loops to while loops: 2
- i. for(m=1; m<10; m++)
printf(m);
 - ii. for(; scanf("%d", &m) != -1;)
printf(m);
- (c) Describe the two ways of passing parameters to functions. When do you prefer to use each of this? 3

- (d) Find the errors in the following functions calls: 2
- i. void xyz(); ii. xyx (int x, int y)
- iii. xyx (void); iv. xyz () + xyz ()
- (e) Describe with examples, the different ways of assigning values to structure members. 3
- (f) What does the following segment do? 3
- ```
for (i=1; i<=5; i++)
{
 fscanf(stdin, "%s", name);
 fprintf(fp, "%s", name);
}
```
- 4.(a) What is a data structure? Why is an array called a data structure? 1+2
- (b) What is a pointer? How is a pointer initialized? 1+2
- (c) Given the following declarations: 2
- ```
int x=10, y=10;
int *p1 = &x, *p2= &y;
```
- What is the value of each of the following expression?
- i. (*p1)++ ii. *p1 + (*p2)--
- iii. --(*p2) iv. ++ (*p2)- *p1
- (d) What are the arithmetic operator's that are permitted on pointers? What is wrong with the following code? 2+2
- ```
int **p1, *p2;
p2= &p1;
```
- (e) Write a C program on linear search where you can find the location of an item (Clue: A linear array DATA with N elements, a specific ITEM of information are given, find the location LOC of ITEM in the array DATA.) 3

**Sylhet Engineering College, Sylhet**  
**(Shahjalal University of Science & Technology)**  
**Department of Computer Science and Engineering**

Final Examination-2024

1<sup>st</sup> Year 1<sup>st</sup> Semester

Course No: MAT 0541 1101

Course Title: Coordinate Geometry and Linear Algebra

Time: 03 (Three) hours

Full Marks: 60

N.B. : (i) Answer all the questions from each PART  
 (iii) Marks allotted are indicated in the margin

(ii) Use separate answer scripts for each PART  
 (iv) Special Instruction (if any)-----N/A-----

**Part A**  
**[Answer three questions]**

1. a) Transform the axes inclined at  $30^\circ$  to the original axes the equation, 04  
 $x^2 + 2\sqrt{3}xy - y^2 = 2a^2$
- b) Show that the lines joining the origin to the intersection of  $x^2 + y^2 + 19x + 4y - 3 = 0$  and  $3x + 4y = 1$  are at right angles. 06

OR

- a) Reduce the equation  $36x^2 + 24xy + 29y^2 - 72x + 126y + 81 = 0$  to the standard form. Find also its lengths, equation and directions of axes. 10
2. a) Find the equation of the circle which passes through the points (3,5) and (5, -3) and has its center on the line  $2x + y = 7$ . 05
- b) Find the coordinate of the limiting point of the co-axial system determined by the circles  $x^2 + y^2 + 4x + 2y + 5 = 0$  and  $x^2 + y^2 + 2x + 4y + 7 = 0$ . 05
3. a) Find the equation of the parabola whose vertex is the point (2,1) and whose directrix is the line  $4x + 3y - 6 = 0$ . 05
- b) In the ellipse  $\frac{x^2}{9} + \frac{y^2}{4} = 1$  form the equation to that particular which is bisected at the point (2,-1). 05

**Part B**  
**[Answer three questions]**

4. a) Define Homogeneous system of linear equations with example. Solve the following system of linear equation, 2+3

$$\begin{aligned} x_1 - 2x_2 + 3x_3 &= 7 \\ 2x_1 + x_2 - x_3 &= 1 \\ x_1 - x_2 - x_3 &= -6 \end{aligned}$$

- b) Determine whether A is invertible or not, and if so, find the inverse. 05
- $$A = \begin{bmatrix} 1 & 0 & 1 \\ 1 & 1 & 0 \\ 0 & 1 & 1 \end{bmatrix}$$

5. a) Define Basis of a vector space. Show that the following set of vectors is a basis of  $R^3$  1+4  
 $\{(1,1,-1), (1,0,2), (1,1,1)\}$

- b) Define dimension of a vector space. Determine the dimension of 1+4  
 $W = L\{(1, -2, 5, -3), (2, 3, 1, -4), (3, 8, -3, -5)\}$ .

OR

a) Let  $V_1 = (1,6,4)$ ,  $V_2 = (2,4,-1)$ ,  $V_3 = (-1,2,5)$  and  $W_1 = (1,-2,-5)$ ,  $W_2 = (0,8,9)$ . Show that  $\text{span}\{V_1, V_2, V_3\} = \text{span}\{W_1, W_2\}$  04

b) Prove that the vectors  $(1,2,0)$ ,  $(0,5,7)$  and  $(-1,1,3)$  form a basis for  $\mathbb{R}^3$ . 02

c) Determine a basis and the dimension for the solution space of the following homogeneous system, 04

$$x-3y+z=0$$

$$2x-6y+2z=0$$

$$3x-9y+3z=0$$

6. a) Find the characteristic equation, the eigen-values and bases for the eigenspace of the matrix 07

$$A = \begin{bmatrix} 6 & 3 & -8 \\ 0 & -2 & 0 \\ 1 & 0 & -3 \end{bmatrix}$$

b) Suppose that  $T: T(A) = \text{tr}(A)$  is a mapping whose domain is the vector space  $M_{22}$ . Determine whether  $T$  is Linear Transformation and if so, find its Kernel. 03

**Sylhet Engineering College, Sylhet**  
**(Shahjalal University of Science & Technology)**  
**Department of Computer Science and Engineering**

**Final Examination**  
**Course No: CSE 0541 1143**  
**Time: 03 (Three) hours**

**1<sup>st</sup> Year 1<sup>st</sup> Semester**  
**Course Title: Discrete Mathematics**  
**Full Marks: 60**

N.B. : (i) Answer all the questions from each PART  
 (iii) Marks allotted are indicated in the margin

(ii) Use separate answer scripts for each PART  
 (iv) Special Instruction (if any)-----N/A-----

**Part A**  
**[Answer three questions]**

1. a) Define a set and list the different types of sets. Give an example for each type. 02
  - b) Write the conditions of the Ackerman function and what will be the ans of A(1,3)? 04
  - c) Out of 100 students, 50 like English, 35 like Science, 29 like Math. 6 like Math and English, 8 like English and Science, 6 like Science and Math. Only 5 like all three subjects. How many students don't like any of these subjects? (Use Venn diagram) 04
  
  2. a) What is a binary tree give an example. 02
  - b) **Pre-order:** 1, 2, 3, 4, 5, 6, 7, 8, 9, 10, 11, **In-order:**3, 2, 5, 4, 1, 7, 6, 9, 10, 8, 11 using this draw a binary tree. 03
  - c) Apply the **Huffman algorithm** to construct the binary Huffman tree and determine the corresponding Huffman codes for each node. 05
- | Node  | A  | B  | C | D  | E | F  | G |
|-------|----|----|---|----|---|----|---|
| Weigh | 10 | 30 | 5 | 15 | 2 | 15 | 5 |
| t     |    |    |   |    | 0 |    |   |
- 
3. a) Define the terms: Euler path, Hamiltonian path, and give an example of where each might be applied in computing. 02
  - b) What is minimum cost spanning tree? Give an example of subgraph 02
  - c) Use Prim's algorithm to find the minimum cost spanning tree. 06

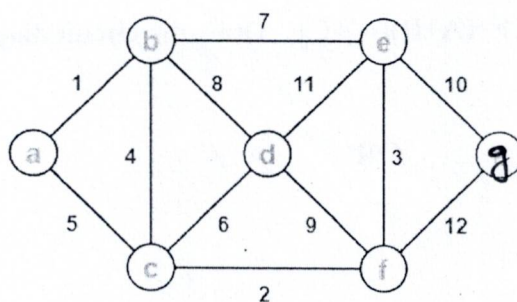

**OR**

- a) Construct the truth table for  $(p \rightarrow q) \leftrightarrow (\neg q \rightarrow \neg p)(p \wedge q)$ . Is this a tautology? 03
- b) How many ways can you arrange the letters in the word *COMPUTE*? 03
- c) Write an algorithm to compute the GCD of two positive integers using the Euclidean algorithm. 04

**Part B**  
**[Answer three questions]**

4. a) A function  $f: \mathbb{N} \rightarrow \mathbb{N}$  is defined as  $f(x) = 2x + 1$ . Determine if  $f$  is one-to-one and onto. Justify your answer. 03

b) Use BFS to travel this graph – 07

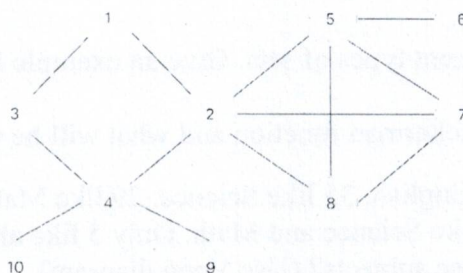

5. a) What do you mean by a graph? 01

b) Distinguish between Floyd-Warshall and Dijkstra algorithm. 02

c) Use Floyd-Warshall algorithm to find the shortest path 07

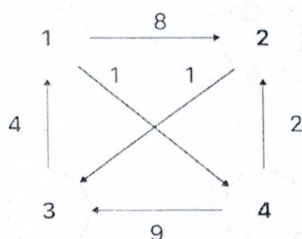

6. a) Express the Boolean function  $F = A'B + AB'$  in a minimized form. What logic gate does it represent? 03

b) Design a logic circuit for the function  $F = (A+B)(A'+C)$ . Draw the circuit diagram. 03

c) Explain Merge sort. 04

**OR**

6. a) Explain binary search. 02

b) Using 2's complement solve the problem  $(-6) + (-10)$ . 04

c) Solve the equation  $xy' + xyz + x'y'z' + x'yz'$  with K-map. 04

**Sylhet Engineering College, Sylhet**  
**(Shahjalal University of Science & Technology)**  
**Department of Computer Science & Engineering**

**Final Examination, 2024**

**Course No: SSS 0312 1100**

**Time: 03 (Three) hours**

**1<sup>st</sup> Year 1<sup>st</sup> Semester**

**Course Title: History of the Emergence of Independent Bangladesh**

**Full Marks: 60**

N.B. : (i) Use separate answer scripts for each PART

(ii) Marks allotted are indicated in the margin

(iii) Special Instruction (if any)-----N/A

**PART-A**

**(Answer 3 Questions)**

- |    |                                                                          |    |
|----|--------------------------------------------------------------------------|----|
| 1. | Why the language movement is important in the history of Bengali nation? | 10 |
| 2. | What is military rule? Describe its merits and demerits.                 | 10 |
| 3. | Describe the 'Indian Independence Act in 1947'                           | 10 |

**OR**

|                                            |    |
|--------------------------------------------|----|
| Why did the British India divided in 1947? | 10 |
|--------------------------------------------|----|

**PART-B**

**(Answer 3 Questions)**

- |    |                                                                 |    |
|----|-----------------------------------------------------------------|----|
| 4. | Describe the significance of the national election in 1970.     | 10 |
| 5. | What was the situation and result of the mass uprising in 1969? | 10 |
| 6. | What do you know about our war of independence in 1971?         | 10 |

**OR**

|                                                                            |    |
|----------------------------------------------------------------------------|----|
| Signify the Struggle of the people during the war of independence in 1971. | 10 |
|----------------------------------------------------------------------------|----|

**Sylhet Engineering College, Sylhet**  
**(Shahjalal University of Science & Technology)**  
**Department of Computer Science & Engineering**

**Final Examination, 2024**  
**Course No: PHY 0533 1103**  
**Time: 03 (Three) hours**

**1<sup>st</sup> Year 1<sup>st</sup> Semester**  
**Course Title: Physics**  
**Full Marks: 60**

N.B. : (i) Answer all questions from each PART (ii) Use separate answer scripts for each PART  
 (iii) Marks allotted are indicated in the margin (iv) Special Instruction (if any)-----N/A-----

**PART-A**  
**(Answer 3 Questions)**

1. (a) State and prove Carnot's theorem. 03  
 (b) How can you amplify the following waves by using interference? 04

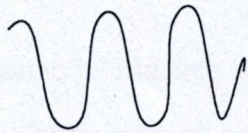

Fig (i)

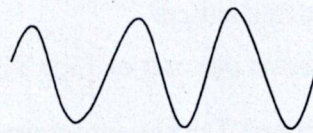
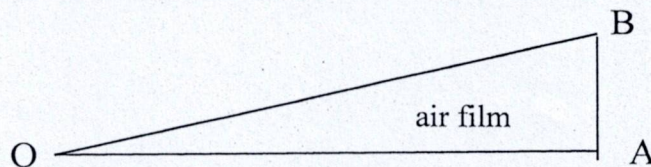

Fig (ii)

- (c) State 1<sup>st</sup> law of thermodynamics. Describe limitations of this law 03

**OR**

1. (a) What is fringes width? 02  
 (b) How can you determine unknown wavelength by using plano-convex lens, glass plate and other associate equipments? 04  
 (c) For the following arrangement, OA=15cm and AB=0.005cm. if wavelength  $\lambda=6000\text{\AA}$ , find fringe width. 04



2. (a) Show that kinetic energy associated with each degree of freedom is  $1/2KT$ . 03  
 (b) Calculate the total random kinetic energy of 2g of Helium at 200K 03  
 (c) Derive an Expression of mean free path. 04
3. (a) What is temperature? Write down the significance of 1<sup>st</sup> law of thermodynamics. 03  
 (b) Calculate the work done by gas during an adiabatic process. 04  
 (c) A Carnot engine whose low temperature reservoir is at 7°C has an efficiency of 50%.it is desired to increase the efficiency to 70%. By how many degrees should the temperature of the high temperature reservoir be increased? 03

**PART-B**  
**(Answer 3 Questions)**

4. (a) Write short notes on- 03  
     i) Mean free path  
     ii) Entropy
- (b) show that the acceleration of a oscillatory particle is maximum when the displacement is maximum. 03  
 (c) Show that the oscillation of a mass between two spring is a simple harmonic motion. 04

OR

4. (a) What do you mean by Lissajou's figure? Write an application of Lissajou's figure. 03  
(b) Discuss the following Lissajous' figures. 03

fig(1)

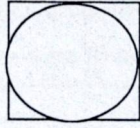

fig(2)

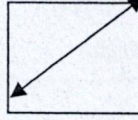

- (c) A block of mass 0.5kg is hung from a spring whose spring constant is 5N/m and the damping constant is 2kg/s. Does the mass vibrate? Find  $w_0$  and  $w'$ . 04
5. (a) What is unit cell. Discuss crystal structure. 03  
(b) What is co-ordination number? What are the co-ordination number for a (i) SC (ii) BCC (iii) FCC structure of crystal? 04  
(c) Discuss any three Bravais lattice. 03
6. (a) Find the number of atoms per unit cell for SC, BCC and FCC structure of crystal. 03  
(b) What is packing fraction? Derive expression for the packing fraction of SC, BCC and FCC structure of crystal. 04  
(c) In a crystal, a lattice plane cuts intercepts of  $a$ ,  $2b$  and  $3c$  along the three axes, where  $a$ ,  $b$  and  $c$  are primitive vectors of the unit cell. Determine the Miller indices of the given plane. 03

**Sylhet Engineering College, Sylhet**  
**(Shahjalal University of Science & Technology)**  
**Department of Computer Science & Engineering**

**Final Examination, 2024**  
**Course No: EEE 0713 1109**  
**Time: 03 (Three) hours**

**1<sup>st</sup> Year 1<sup>st</sup> Semester**  
**Course Title: Introduction to Electrical Engineering**  
**Full Marks: 60**

N.B. : (i) Use separate answer scripts for each PART  
 (iii) Special Instruction (if any)-----N/A

(ii) Marks allotted are indicated in the margin

**PART-A**  
**(Answer 3 Questions)**

1. (a) How much charge is represented by 4,600 electrons? 2  
 (b) Find the Equivalent resistance from the following networks. 3

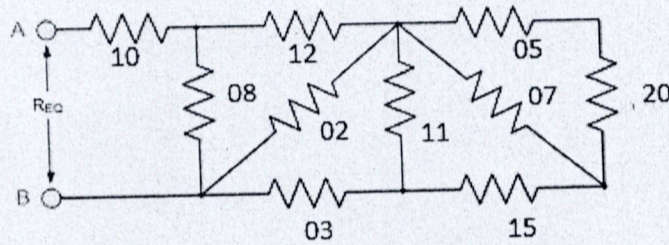

- (c) Obtain the equivalent resistance  $R_{ab}$  for the circuit in **Fig. 1(c)** and use it to find current. 5

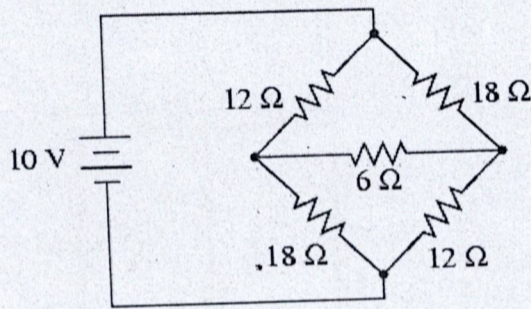

Figure 1(c)

**OR**

1. (a) Explain the difference between AC and DC with suitable examples. 2  
 (b) Compare the advantages and disadvantages of series and parallel circuits in household wiring. 3  
 (c) Convert the  $\Delta$  network in Fig. 1.1(c) to an equivalent Y network: 5

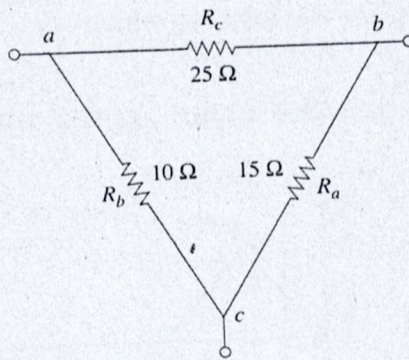

Figure 1.1(c)

2. (a) Define Kirchhoff's Current Law (KCL) and Kirchhoff's Voltage Law (KVL). 2  
 (b) Compare the applications of KCL and KVL in circuit analysis, providing examples where each law is most useful. 3

(c) For the circuit in Fig. 2(c), find voltages  $v_1$  and  $v_2$ .

5

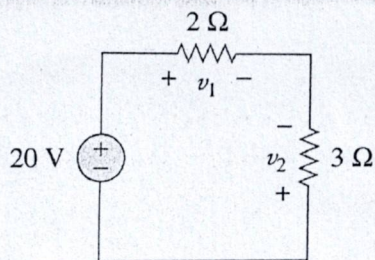

Figure 2(c)

3. (a) Calculate the node voltages in the circuit shown in Fig. 3(a).

5

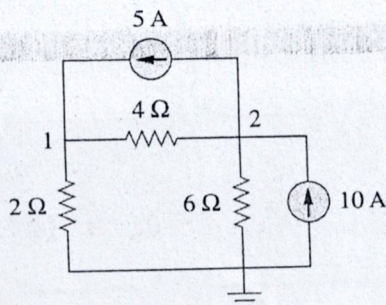

Figure 3(a)

(b) For the circuit in Fig. 3(b), find the branch currents  $I_1$ ,  $I_2$  and  $I_3$  by using, mesh analysis.

5

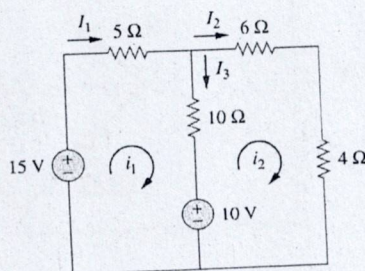

Figure 3(b)

**PART-B**  
(Answer 3 Questions)

4. (a) Define: Capacitor, Capacitance, Inductor and Inductance with their equations. 2
- (b) Draw and explain all the phasors of pure resistive circuit, pure inductive circuit and pure capacitive circuit. Do you know in which circuit, voltage is leading and in which, it is lagging? 3
- (c) Determine the current through a  $200\mu F$  capacitor whose voltage is shown in Fig. 4(c). 5

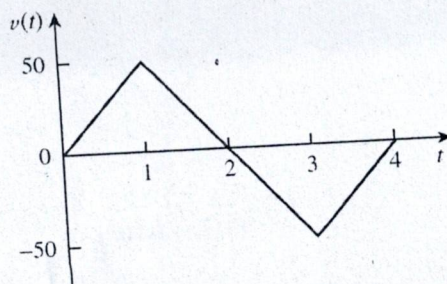

Figure 4(c)

OR

4. (a) Define Sinusoids, Phasors and Frequency. 2  
 (b) Calculate the equivalent inductance for the inductive ladder network in **Fig. 4.1(b)**. 3

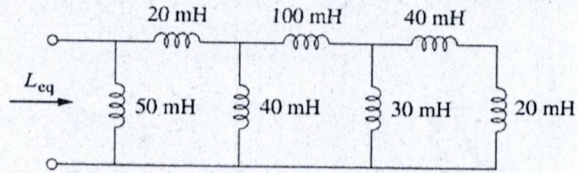

Figure 4.1(b)

- (c) Evaluate these complex numbers: 5  
 (a)  $(40\angle 50^\circ + 20\angle -30^\circ)^{1/2}$   
 (b)  $\frac{10\angle -30^\circ + (3 - j4)}{(2 + j4)(3 - j5)^*}$
5. (a) Find the Thevenin equivalent circuit of the circuit shown in **Fig. 5(a)**, to the left of the terminals a-b. Then find the current through  $R_L = 6\Omega, 16\Omega,$  and  $36\Omega$ . 5

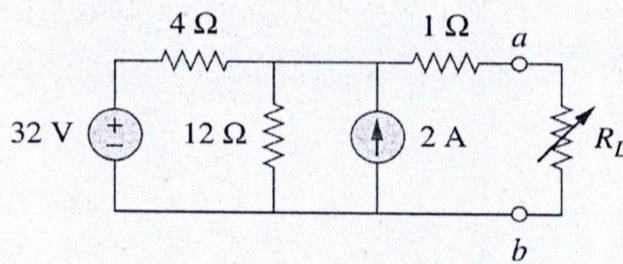

Figure 5(a)

- (b) Use source transformation to find  $v_o$  in the circuit of **Fig. 5(b)**. 5

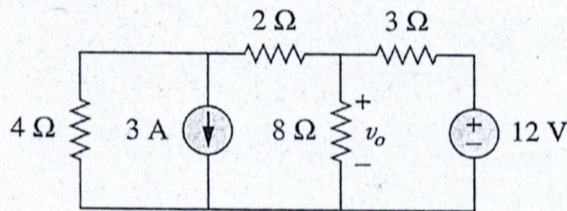

Figure 5(b)

6. (a) Explain power, energy, impedance in an AC circuit. 2  
 (b) Find  $v(t)$  and  $i(t)$  in the circuit shown in **Fig. 6(b)**. 3

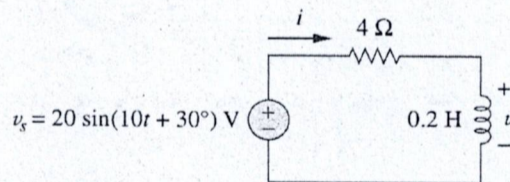

Figure 6(b)

- (c) Calculate  $i_x$  in the circuit of **Fig. 6(c)** using nodal analysis. 5

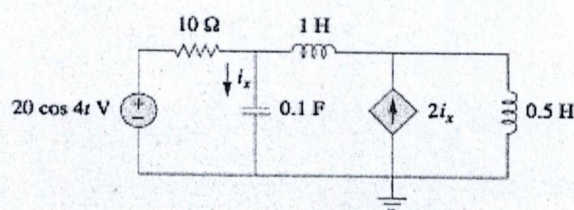

Figure 6(c)