

Government of People's Republic of Bangladesh  
Ministry of Road Transport and Bridges  
Roads and Highways Department



# Bridge Management System (BMS) Manual for Public Users

Final Draft

**August 2018**





## PREFACE

It is a matter of great pleasure that **Bridge Management System (BMS) Manuals** have been developed by the consultants under the Bridge Management Capacity Development Project (BMCDP) of RHD with the cooperation of JICA.

RHD already has Bridge Maintenance Management System called BMMS constructed over 20 years ago, however it is impossible to carry out the bridge asset management developed under BMCDP because of shortage and unsuitable function of BMMS. Therefore, new system was required.

**Bridge Management System (BMS)** has been constructed in order to carry out effective bridge asset management with “database function of bridge basic data, result of inspection and result of evaluation” and “calculation function of priority to be remedy, rough cost estimate of each bridge.”

**The Bridge Management System (BMS) Manual 2018** is composed of 4 parts for each user authority level named as “for System Administrators”, “for Bridge Management Wing”, “for Inspector & Evaluator” and “for Public Users”. The manuals show how to input information into BMS, how to use data of BMS, how to set settings of system and technical note to understand BMS for each user authority level.

Together with the systematic use of this BMS, this manual will be useful to the RHD field staff responsible for direct maintenance, the policy makers of RHD in this area and also the staff who will be involved in maintenance by contract.

We hope that this manual will assist in improving the understanding of the function of bridge structures and their long term durability and serviceability.

Finally, we would like to take this opportunity to thank the experts of JICA Consultant Team for their efforts in preparing the Bridge Management System (BMS) Manual 2018.



**(Rowshan Ara Khanam)**

Project Director of BMCDP

Additional Chief Engineer, Bridge Management Wing

Roads and Highways Department

Sarak Bhaban, Tejgaon, Dhaka

August 2018



# 1. INTRODUCTION

This system named **BMS (Bridge Management System)** is working as “Database of Bridge in all Bangladesh” and “Assistant System of Bridge Asset management”.

Many bridges in Bangladesh are damaged and require management and repair. In order to manage many bridges, Bridge Inspection is very important. Therefore, database function to stock bridge basic information and the result of inspection is required.

At the same time, BMS can support the bridge asset management by calculating Damage score of the bridge and rough cost estimate to repair the bridge automatically.

***For Public User,***

***BMS opens Bridge basic information like as bridge name, location, shape and some photos.***

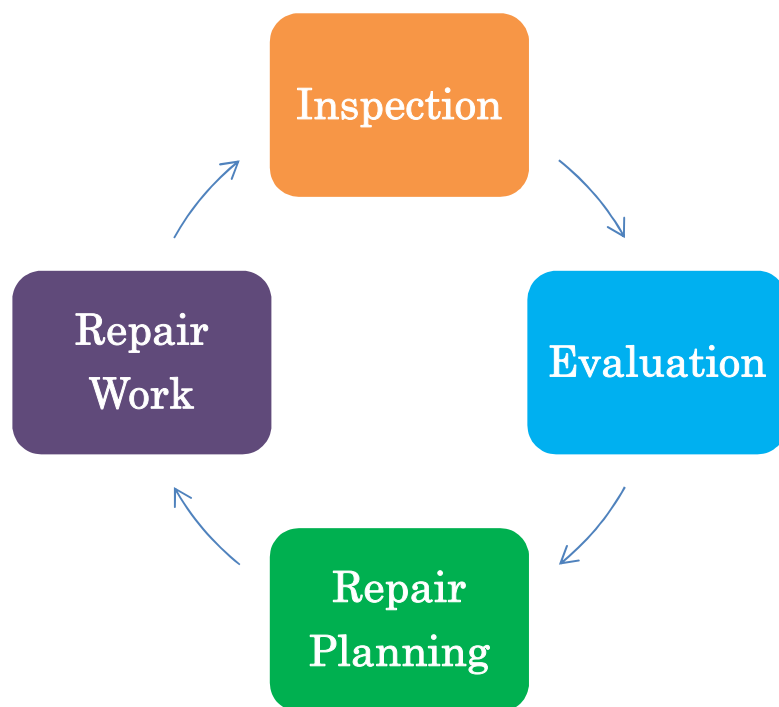

Bridge Asset Management

## 2. HOW TO USE BMS FOR PUBLIC USER

### 2.1 Browsing of BRIDGE LIST

BRIDGE MANAGEMENT SYSTEM (BMS)

BRIDGE LIST

Records per page: 10

Search:

Sl	Map	Bridge No	Bridge Name	Bridge Type	Completion Year	Bridge Length	Road No	LRP Name	Road Name	Zone	Circle	Division	Sub Division	Sl
1		201711082025	<a href="#">Amtola Bailey Bridge</a>	Potable Steel Bridge	2030	12.20	R315	044a	Mawna-Fulbaria-Kaliakair-Dhamrai-Nabinagar	Dhaka	Dhaka	Manikganj	Nayarhat	
2		201711082035	<a href="#">Amtola Bridge</a>	Masonry Arch Bridge	2030	9.30	R315	045a	Mawna-Fulbaria-Kaliakair-Dhamrai-Nabinagar	Dhaka	Dhaka	Manikganj	Nayarhat	
3		R504-22.78	<a href="#">Arongobad Culvert-1</a>	Box Culvert	2009	10.20	R504			Dhaka	Dhaka	Manikganj	Manikganj	
4		23.769	<a href="#">Arongobad Culvert-2</a>	Box Culvert	2009	5.63	R504	23a	Hemayetpur-Singair-Manikganj	Dhaka	Dhaka	Manikganj	Manikganj	
5		23.8090.03	<a href="#">Arongobad Culvert-3</a>	Box Culvert	2010	6.76	R504	24a	Hemayetpur-Singair-Manikganj	Dhaka	Dhaka	Manikganj	Manikganj	
6		201712030453	<a href="#">Arpara Culvert-1</a>	Box Culvert	1997	6.80	N5	73a	Dhaka-Paturia-Kashinathpur-Bogra-Rangpur-Banglabandh	Dhaka	Dhaka	Manikganj	Manikganj	
7		201712030503	<a href="#">Arpara Culvert-2</a>	Box Culvert	1997	6.80	N5	74a	Dhaka-Paturia-Kashinathpur-Bogra-Rangpur-Banglabandh	Dhaka	Dhaka	Manikganj	Manikganj	
8		R50427a	<a href="#">Aulpara Culvert</a>	Box Culvert	2009	6.88	R504	27a	Hemayetpur-Singair-Manikganj	Dhaka	Dhaka	Manikganj	Nayarhat	
9		4832511363	<a href="#">Aynal bridge</a>	RC Girder Bridge	2008	25.40	R504	009a	Hemayetpur-Singair-Manikganj	Dhaka	Dhaka	Manikganj	Manikganj	
10		48346911	<a href="#">Azimpur Bridge</a>	PC Girder Bridge	1992	51.00	R504	013	Hemayetpur-Singair-manikganj	Dhaka	Dhaka	Manikganj	Manikganj	

Showing 1 to 10 of 319 entries

Navigation: Previous 1 2 3 4 5 ... 32 Next

1. User can change number of rows to show in bridge list table. Example: 10, 25, 50, 100.
2. User can search bridge by any values of bridge data.
3. Click “Map” link to show location of the bridge on map.
4. Click bridge name to show basic information (Detailed View) of the bridge.
5. Click “Next” to see next page. Click “Previous” to see previous page.

BRIDGE MANAGEMENT SYSTEM (BMS)

DETAIL VIEW

Bridge Description

This bridge is test case to explain BMS in JCC. The following texts are dummy text known as "Lorem Ipsum".

**Test Sentence**

**Test Sentence**

**Test Sentence**

Bridge Pictures

Details

Bridge No.	9512348627
Bridge Name	Final Trial RC Girder Bridge
Bridge Type	RC Girder Bridge
Completion year	2019
Design load	
Load Restriction	0
Design Standard	Unknown
Carried Utility	
Crossing Under Bridge	Railway
Authority	RHD
<b>Shape</b>	
Bridge Length	60.00
Bridge Width	9.000
Bridge Effective Width	8.000
Total Span	2
Span Width	
Span Height	
Span Length	60
Span Arrangement	25+35
Total Column	1
Column Width	3.000
Column Height	5.000
Skew Angle Degree	90

# A P P E N D I X

## Bridge and Culvert Type

### <Concrete Bridge >

#### 1. Small Slab Bridge (Former "Slab Culvert")

A structure comprising a slab(s) without girders supported on abutments/piers and having a length of 6.0m or less measured at right angles between the extreme vent way boundaries.

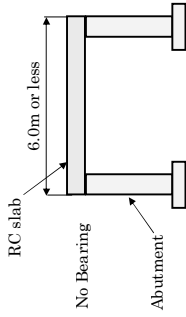

#### 2. RC Slab Bridge

In general, the span is less than 16m

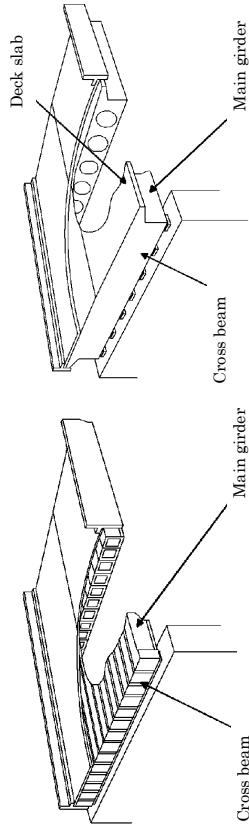

#### 3. RC Girder Bridge

In general, the span is less than 20m. In special case It can be less than 30m

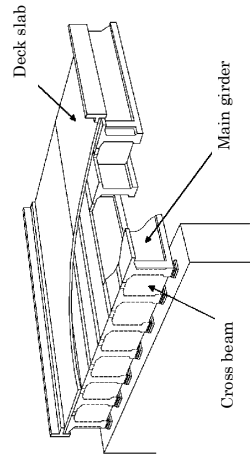

Bhuvagati Bridge in SirajGanj

#### 4. PC Girder Bridge

In general, the span is more than 20m

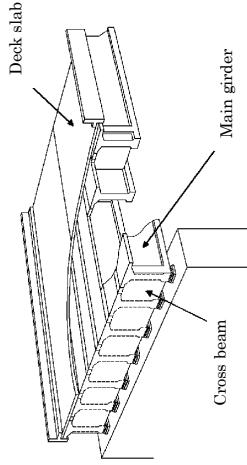

Kanchpur Bridge in Narayanganj

#### 5. PC Box Girder Bridge

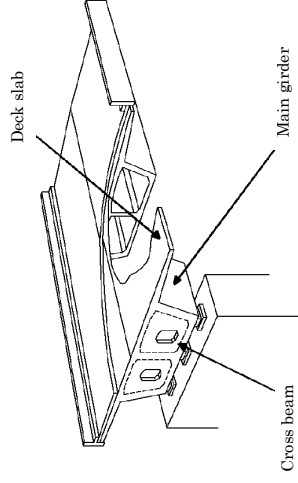

Rupsha Bridge

#### 6. Concrete Arch Bridge

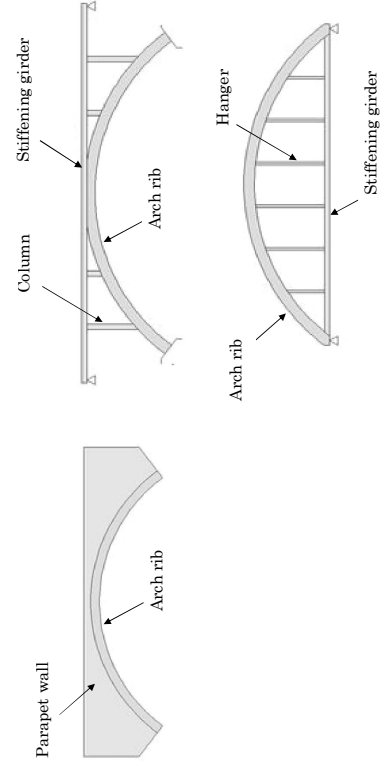

**7. Cantilever Bridge with Hinge**

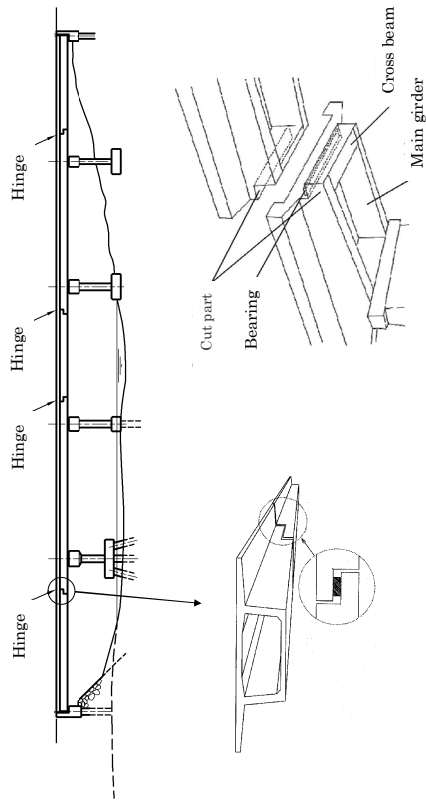

**8. Rigid Frame Bridge**

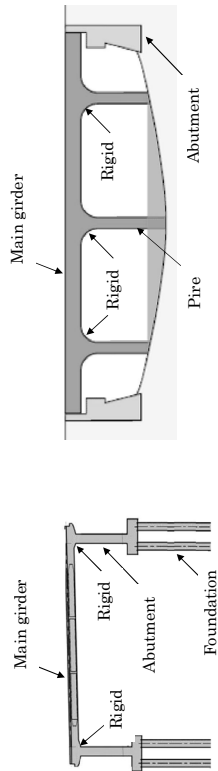

**9. Cable- Stayed Bridge**

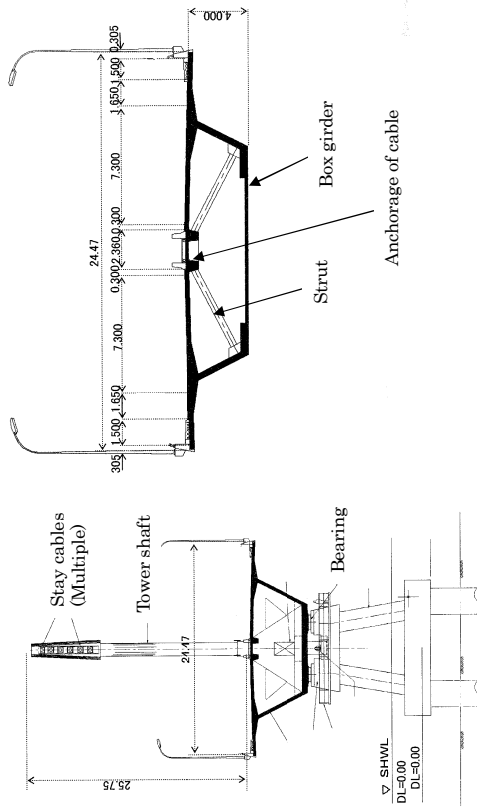
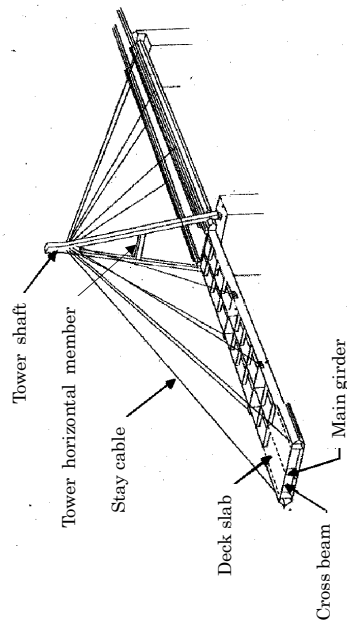

Section and elements of the 3<sup>rd</sup> Kamaphuli Bridge (Extradosed bridge)

< Steel Bridge >

10. Steel Girder Bridge

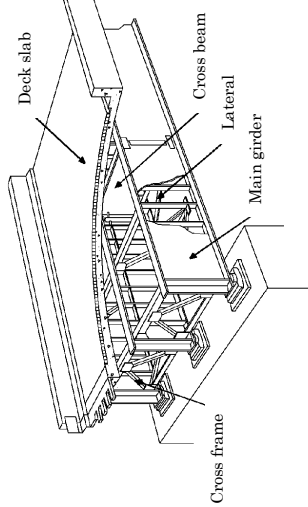

11. Steel Box Girder Bridge

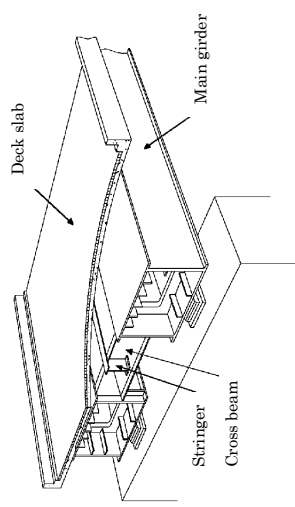

12. Steel Arch Bridge

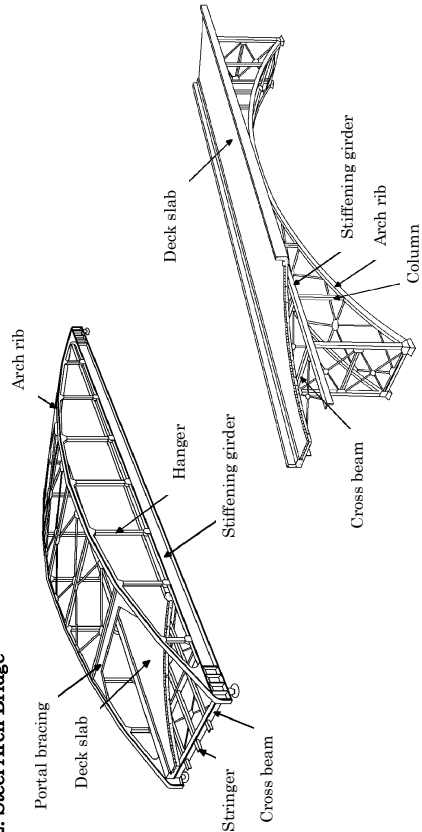

- 13. Truss Bridge with Steel Deck
- 14. Truss Bridge with RC slab
- 15. Truss Bridge with Timber Deck

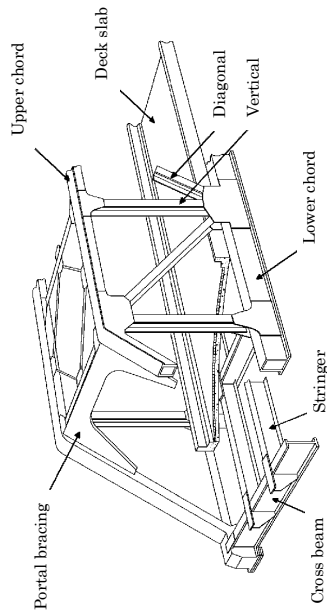

- 16. Portable Steel Bridge with Steel Deck
- 17. Portable Steel Bridge with Timber Deck

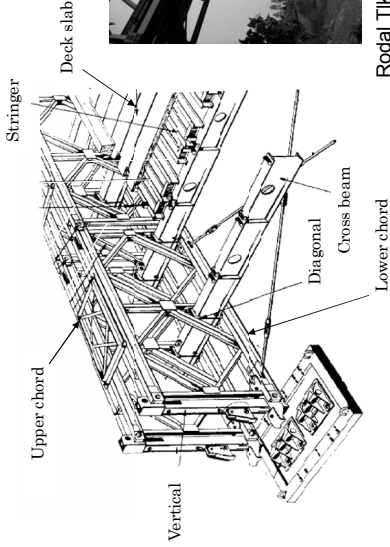

Rodal Tiki Portable Steel Bridge in Manikganj

< Masonry Arch Bridge >

18. Masonry Arch Bridge

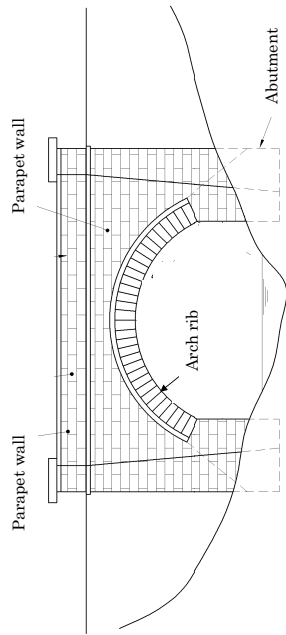

< Culvert >

19. Box Culvert

A structure which is in a box form (single or multiple cell) in cross-section which contains a ground slab, and where the floor, walls and deck are of monolithic construction, i.e. there are no joints or bearings within the structural unit.

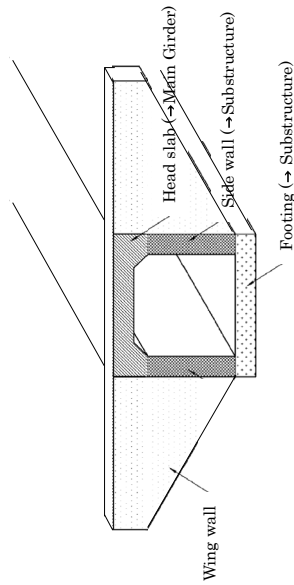

Substructure Type

< Abutment >

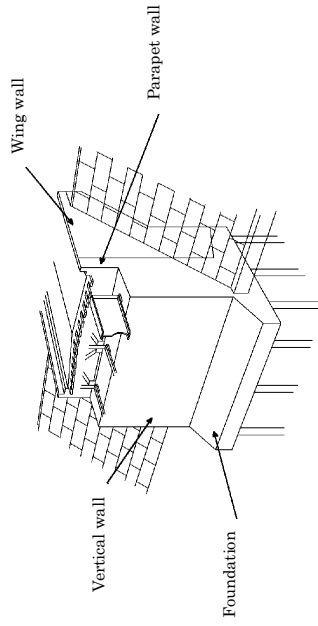

< Pier >

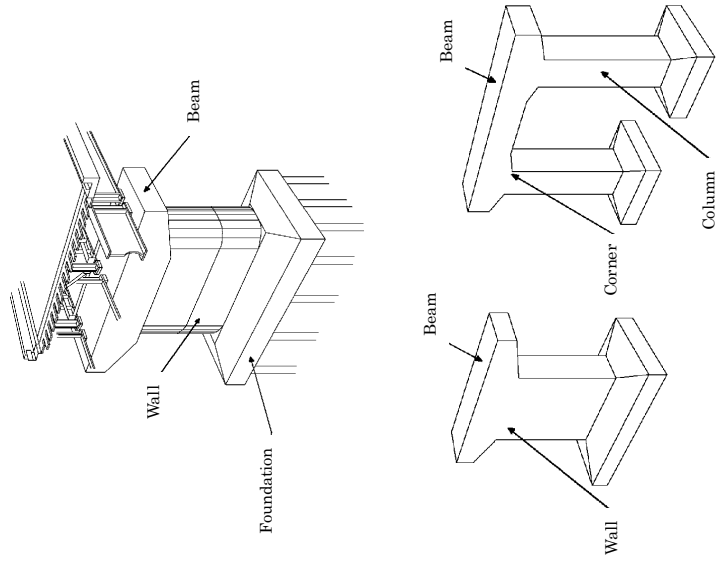

**Bearings**

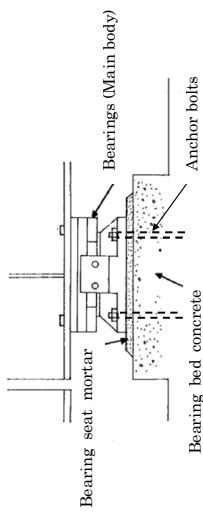

**Deck Surface**

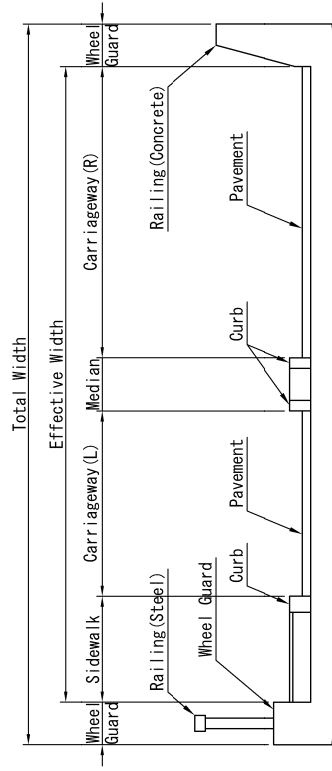
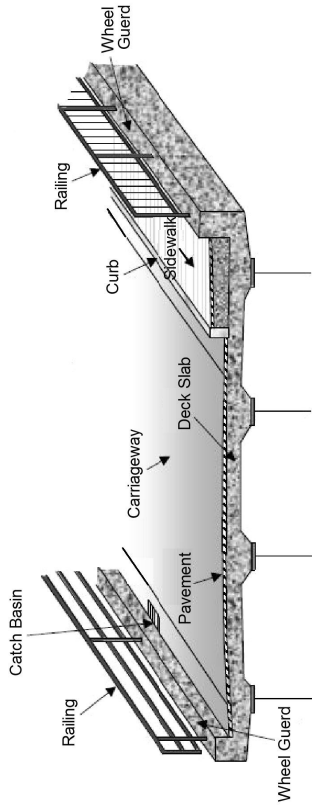

**Expansion Joint**

<Steel>

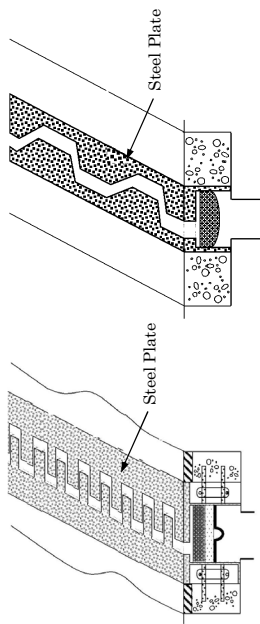

<Rubber>

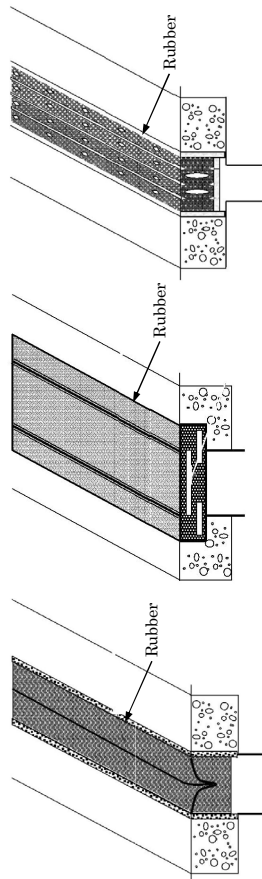

<Others>

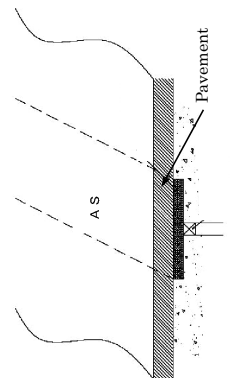

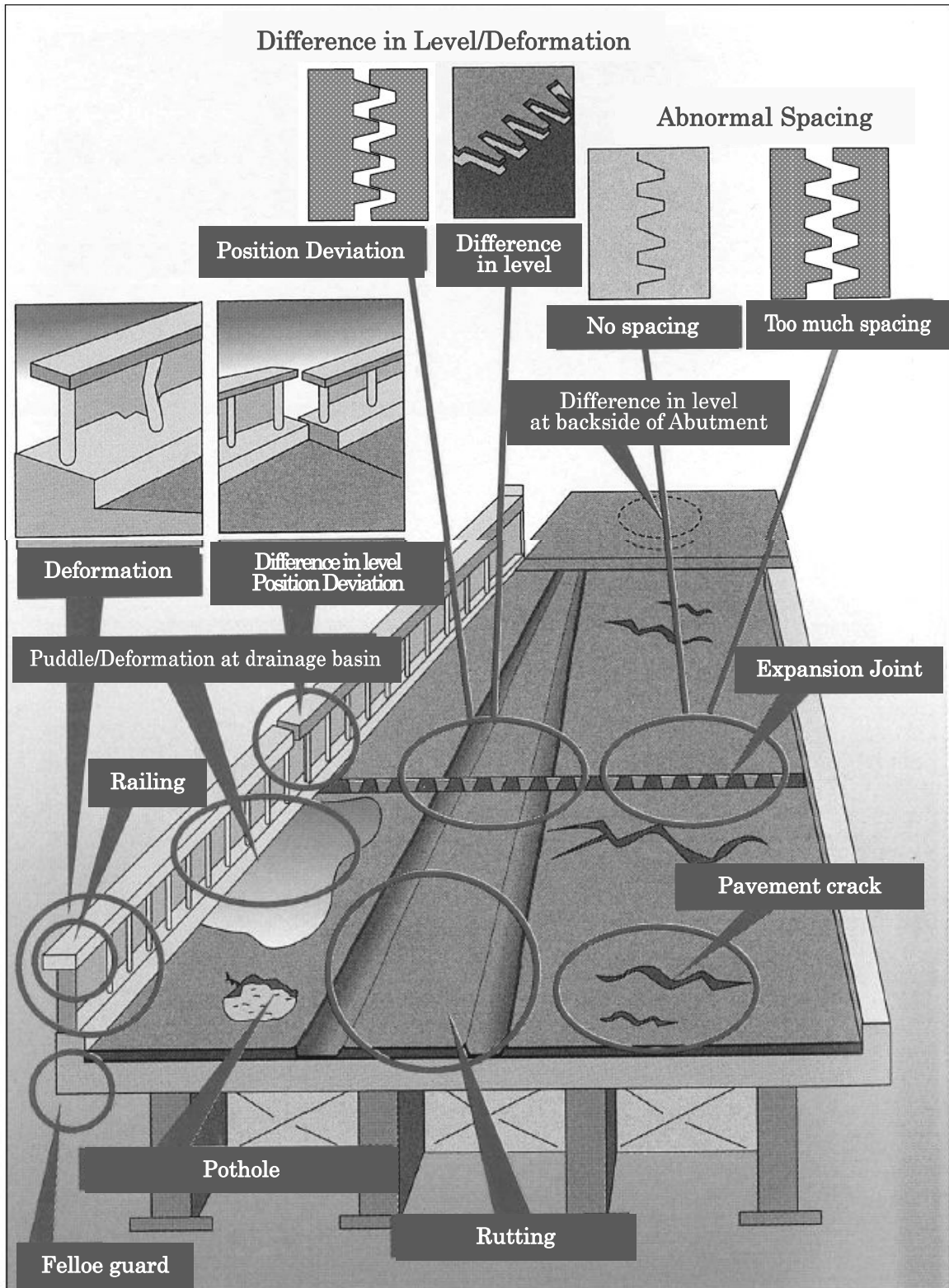

Figure Summary of Possible Defects and Locations

## 1. Types of Defects and Rating

The types of defects and ratings defined in this manual are summarized as follows:

Table 1 Summary of Types of Defects and Rating

Material	No.	Faults & Defects	Rating of Defects					Remarks
<b>Steel</b>								
	1)	Corrosion	a	b	c	d	e	Depth & Extent
	2)	Crack in Steel	a	-	c	-	e	
	3)	Loose or Missing Bolts	a	-	c	-	e	
	4)	Fracture	a	-	-	-	e	
	5)	Deterioration of Paint System	a	-	c	d	e	Paint, Metal Spraying, Weathering Steel
<b>Concrete</b>								
	6)	Crack	a	b	c	d	e	Crack Width & Spacing
	7)	Spalling /Exposed Rebar	a	-	c	d	e	
	8)	Water leakage/ Efflorescence	a	-	c	d	e	
	9)	Fallen out of Deck Slab	a	-	-	-	e	
	10)	Cracking of Deck Slab	a	b	c	d	e	Crack Width & Spacing
	11)	Delamination	a	-	-	-	e	
<b>Other Materials</b>								
Other Materials	12)	Abnormal Spacing	a	-	c	-	e	T $\geq$ 20mm or not
	13)	Difference in Level	a	-	c	-	e	
	14)	Abnormal Bituminous Pavement	a	-	c	-	e	
	15)	Functional Disorder of Bearings	a	-	-	-	e	
	16)	Other Types of Defects	a	-	-	-	e	Illegal Occupation, Scrawl, Missing of Sealing material, Fire Damage etc.
<b>Common Defects</b>								
Common	17)	Defects of Reinforcing Materials for Rehabilitation/Strengthening	a		c		e	Steel Plate, Fiber, Concrete Member, Painting
	18)	Abnormal Anchorage	a	-	c	-	e	Anchorage of PC Tendon
	19)	Discoloration/Deterioration of Materials	a	-	-	-	e	Concrete, Rubber, Plastics
	20)	Water Leakage/Puddle	a	-	-	-	e	
	21)	Abnormal Noise/Vibration	a	-	-	-	e	
	22)	Abnormal Deflection	a	-	-	-	e	
	23)	Deformation/Break	a	-	c	-	e	
	24)	Accumulation of Debris	a	-	-	-	e	
	25)	Settlement/Tilt/Movement	a	-	-	-	e	
	26)	Scouring	a	-	c	-	e	





Supported by JICA