



Northern Electricity Supply PLC
(An Enterprise of Bangladesh Power Development Board)
Project Office
Network Infrastructure Development and
Modernization of Distribution System in NESCO area
Meherchondi Bidyut Office, NESCO, Rajshahi
Email: nidmpdc.project@nesco.gov.bd

Reference NO. 27.29.0000.129.07.004.25-44

Date: 19/06/2025

Name of Project: "Network Infrastructure Development and Modernization of Distribution System in NESCO area"
Title of Contract: "Design, Supply, Installation, Testing, and Commissioning of Nine (9) 33/11 KV AIS Substation Upgradation in Rangpur Zone."
Package No.: Package-6
IFB No.: 27.29.0000.129.07.004.25-29, Date: 24/04/2025

Bid Bulletin No. 2

[Date of Issue- 19/06/2025]

NESCO, the Employer, advises bidders of the following **amendment(s) to the Bidding Document/ IFB captioned above.**

| Sr. No. | Reference | Original Clause/Sub-Clause | Amended Clause/Sub-Clause/Item |
|---------|---|--|--|
| 1. | Instructions to Bidders (ITB) Data Sheet 7.1 | For clarification purposes only, the Employer's address is: Superintending Engineer (Procurement) & Project Coordinator Network Infrastructure Development and Modernization of Distribution System in NESCO Area NESCO, Meherchandi Bidyut Office, Rajshahi, Bangladesh. Telephone: +880721-774900 E-mail: nidmpdc.project@nesco.gov.bd | For clarification purposes only, the Employer's address is: Project Coordinator Network Infrastructure Development and Modernization of Distribution System in NESCO Area NESCO, Meherchandi Bidyut Office, Rajshahi, Bangladesh. Telephone: +880721-774900 E-mail: nidmpdc.project@nesco.gov.bd |
| 2. | Instructions to Bidders (ITB) Data Sheet 47.1 | The procedures for Bidding-Related Complaints are referenced in Appendix 7 of the Procurement Regulations for ADB Borrowers. The Bidder should submit its complaint following these procedures, in writing, to: Superintending Engineer (Procurement) & Project Coordinator Network Infrastructure Development and Modernization of Distribution System in NESCO Area NESCO, Meherchandi Bidyut Office, Rajshahi, Bangladesh. E-mail: nidmpdc.project@nesco.gov.bd | The procedures for Bidding-Related Complaints are referenced in Appendix 7 of the Procurement Regulations for ADB Borrowers. The Bidder should submit its complaint following these procedures, in writing, to: Project Coordinator Network Infrastructure Development and Modernization of Distribution System in NESCO Area NESCO, Meherchandi Bidyut Office, Rajshahi, Bangladesh. E-mail: nidmpdc.project@nesco.gov.bd |
| 3. | IFB 4[a]- Bidder's Experience | "The scope of each contract must include Design, Supply, Installation & Commissioning of 33/11 KV | Deleted. |

| Sr. No. | Reference | Original Clause/Sub-Clause | Amended Clause/Sub-Clause/Item |
|---------|---|---|--|
| | | GIS/AIS Substation at NESCO or above." | |
| 4. | Instructions to Bidders (ITB) Data Sheet 21.1 | <p>The Bidder shall furnish a bid security in the amount of: USD 140,000.00</p> <p>A bid security in the form of a bank guarantee issued by a bank located outside the Employer's country shall be endorsed by a correspondent bank registered in the Employer's country.</p> | <p>The Bidder shall furnish a bid security in the amount of: USD 140,000.00 or equivalent amount in BDT</p> <p>A bid security in the form of a bank guarantee issued by a bank located outside the Employer's country shall be endorsed by a correspondent bank registered in the Employer's country.</p> |
| 5. | Section 3- Sub Clause-2.3.2 (Average Annual Turnover) (page 3-15) | <p>Minimum average annual turnover of: USD 18.50 million calculated as total certified payments received for contracts in progress or completed, within the last three (3) years.</p> | <p>Minimum average annual turnover of: USD 14.50 million calculated as total certified payments received for contracts in progress or completed, within the last three (3) years.</p> |
| 6. | Section 3- Sub Clause 1.3.4 (Functional Guarantees of the Facilities) | None | <p>Functional Guarantees of the Facilities</p> <p>The Bidder shall declare the guaranteed values of No Load Loss and Full Load Loss in the Guaranteed Technical Particulars (GTP). Any bid quoting values above the upper limits specified in the GTP (Section 6, Clause 2.3.19, Sl. No. 9.13) will be considered non-responsive and will not proceed to further evaluation.</p> <p>If a Bidder quotes No Load Loss and/or Full Load Loss values below the lower limits stated in the GTP (Section 6, Clause 2.3.19, Sl. No. 9.13), the capitalization cost during evaluation will be based on the lower limit values for both losses, regardless of the bidder's quoted figures.</p> <p>All quoted values for No Load Loss and Full Load Loss must be supported by appropriate loss calculations. Bids that fail to provide these supporting calculations will also be treated as non-responsive.</p> <p>To ensure reliable and cost-effective use of materials, the fixed and running losses of the transformer should be minimized. The capitalized cost of losses will be used in the evaluation of bids, based on the following formula:</p> |

| Sr. No. | Reference | Original Clause/Sub-Clause | Amended Clause/Sub-Clause/Item |
|---------|-----------|----------------------------|---|
| | | | <p>$C = 68,706 \times e \times P_0 + 54,964 \times e \times PFL$</p> <p>Where:</p> <p>C = Capitalized cost of transformer losses (in Bangladeshi Taka) e = Average Billing Rate, Tk 9.07/KWh P₀ = No Load Loss (kW) at rated voltage, normal tap, rated frequency PFL = Full Load Loss (kW) at rated voltage, normal tap, rated frequency under ONAF condition at 75°C, including auxiliary losses</p> <p>The capitalized loss cost (C) will be added to the quoted price, for comparison purposes only, to determine the evaluated cost of the transformer.</p> <p>Test & Inspection- Transformer will be tested during technical orientation & quality acceptance and will be accepted if the measured transformer losses are within the offered value or within the following tolerance with deduction of amount from the contract price as below:</p> <p>i) Any component loss (No load loss or Full load loss) may exceed up to 15% of the offered component loss, provided that the total loss((No load loss + Full load loss) shall not exceed 10% of the offered total loss. If any component loss exceeds 15% of the offered component loss, the full consignment will be rejected.</p> <p>ii) Total loss (No load loss + Full load loss) may exceed up to 10% of the offered total loss. If it exceeds 10%, the full consignment will be rejected.</p> <p>iii) Percentage Impedance may vary up to ±10% of the specified value. If the value exceeds the tolerance (±10%), the full consignment will be rejected.</p> <p>Transformer will be tested during factory test witness and will be accepted if the measured transformer losses are within the offered value or within the acceptable limit as specified in (i), (ii) and (iii) provided an amount will be deducted from the Contract price for the loss(s) exceeding the offered/declared loss(s) according to the following formula:-</p> |

| Sr. No. | Reference | Original Clause/Sub-Clause | Amended Clause/Sub-Clause/Item | | | | | | |
|---------------------------|--|----------------------------|--|-----------------------|--|----------------------|---|---------------------------|----------|
| | | | <p>Amount to be deducted from the Contract price. = Contract Price x {(Measured loss - Specified loss /declared loss) ÷ Specified loss/declared loss} X %MT</p> <p>Where,</p> <table border="1" data-bbox="975 524 1390 837"> <tr> <td data-bbox="975 524 1187 696">Measured Loss (in KW)</td> <td data-bbox="1187 524 1390 696">Measured Average No load Loss* 1+ Measured Average Full Load Loss* 2.</td> </tr> <tr> <td data-bbox="975 696 1187 779">Offered Loss (in KW)</td> <td data-bbox="1187 696 1390 779">Offered No Load Loss + Offered Full load loss</td> </tr> <tr> <td data-bbox="975 779 1187 837">Transformer Economic Life</td> <td data-bbox="1187 779 1390 837">20 Years</td> </tr> </table> <p>%MT (Percentage of Monetized Transformer) = % of the Monetized Transformer found during factory test witness by NESCO's inspection team whose measured loss(s) (No load loss or Full load loss or Both) exceed the offered loss (No load loss or Full load loss or Both) but remain within acceptable limit. For example : If total no. of transformers to be inspected is 80 and the no. of selected transformers during QAT/pre-delivery inspection is 8, 6 nos. are found within the offered losses and 2 nos. are found exceeding the offered losses then the %MT will be (2/8)x100=25%</p> <p>* 1Measured Average No Load Loss = [Sum of the measured No-load losses of the tested transformer(s) exceeding the offered No-load loss ÷ Nos. of tested transformer(s) which exceeds the offered No-load loss]</p> <p>* 2Measured Average Full Load Loss = [Sum of the measured Full-load losses of the tested transformer(s) which exceeding the offered Full-load loss ÷ Nos. of tested transformer(s) which exceeds the offered Full-load loss]</p> <p>If, upon testing, the actual losses exceed the guaranteed values, the contract will be subject to cancellation under the following conditions: Total loss deviation exceeds 10% Component loss deviation exceeds 15% (unless total losses exceed</p> | Measured Loss (in KW) | Measured Average No load Loss* 1+ Measured Average Full Load Loss* 2. | Offered Loss (in KW) | Offered No Load Loss + Offered Full load loss | Transformer Economic Life | 20 Years |
| Measured Loss (in KW) | Measured Average No load Loss* 1+ Measured Average Full Load Loss* 2. | | | | | | | | |
| Offered Loss (in KW) | Offered No Load Loss + Offered Full load loss | | | | | | | | |
| Transformer Economic Life | 20 Years | | | | | | | | |

Or

[Signature]

| Sr. No. | Reference | Original Clause/Sub-Clause | Amended Clause/Sub-Clause/Item |
|---------|--|---|--|
| | | | 10%, in which case the 10% threshold prevails) |
| 7. | Section 6- Sub Clause-1.1.2 (SL-15), 1.1.3 (SL-15), 1.1.4 (SL-15), 1.1.5 (SL-15), 1.1.6 (SL-15), 1.1.7 (SL-17), 1.1.8 (SL-15), 1.1.9 (SL-15), 1.1.10 (SL-16) (Civil and building works) | Construction of an oil bund or sump with an oil collection system below the power transformer to gather spilled or leaked oil, capable of holding a minimum of 12,000 liters/110% of the transformer's oil capacity. Proper indication mechanisms have to be implemented. The oil sump will be linked to both transformer pads via 6-inch PVC pipes with strainer for efficient oil collection as per attached indicative drawing (Attachment-11) | Construction of an oil sump with an oil collection system in a suitable place beside the power transformer to gather spilled or leaked oil, capable of holding a minimum of 12,000 liters or 110% of the transformer's oil capacity or minimum size of 2m X 3 m X 2m. Proper indication of oil sump has to be implemented. The oil sump will be linked to both transformer pads via 6-inch PVC pipes with strainer for efficient oil collection as per attached indicative drawing (Attachment-11) |
| 8. | Attachment 11 (Drawing of Oil Sump Collection) | Oil sump size 1m X 1.75m X 1m | Attachment 11 (Indicative Drawing) Oil sump size= 2m X 3 m X 2m or 12,000 liters or 110% of the transformer's oil capacity |
| 9. | Section 6- Sub Clause-1.1.2 (SL-16), 1.1.3 (SL-16), 1.1.4 (SL-16), 1.1.5 (SL-16), 1.1.6 (SL-16), 1.1.7 (SL-18), 1.1.8 (SL-16), 1.1.9 (SL-16), 1.1.10 (SL-17) (Civil and building works) | Construction of various storage areas by brick portioning, including designated spaces for fire extinguishers and tools, each appropriately marked for easy identification and access. | Construction of a tools room to be utilized as a storage area on the ground floor or in the cable room or in suitable place of the substation (where ground space is limited), with a ceiling height of 3.2 meters and a total area of 15 square meters. Wall-mounted or wall-supported metallic rack with dimensions of 2 meters in height, 0.6 meters in depth, and 6 meters in length shall be provided for organized tool storage. The room shall also include designated wall-mounted spaces for fire extinguishers and tools, each clearly labeled to ensure easy identification and access. |
| 10. | Section 6- Sub clause-1.1.2 (SL-9), 1.1.3 (SL-10), 1.1.4 (SL-9), 1.1.5 (SL-9), 1.1.6 (SL-9), 1.1.7 (SL-10), 1.1.8 (SL-9), 1.1.9 (SL-9) & 1.1.10 (SL-9) (Civil & Building Works) | Construction of main entrance gate and side gate with aesthetic view with NAME PLATE/ SIGN BOARD. A signboard has to be fixed on the top of the main entrance gate. Additionally operational advisory signs, equipment labels, and equipment danger labels shall be provided. | Supply of NAME PLATE/ SIGN BOARD with aesthetic view. A signboard has to be fixed on the top of the main entrance gate. Additionally operational advisory signs, equipment labels, and equipment danger labels shall be provided. |
| 11. | Section 4- Price schedule No. 1&2: Page 4-17 (Item-16), Page 4-30 (Item -16), Page 4-48 (Item -16), Page 4-62 (Item -16), Page 4-80 (Item -16), Page 4-93 (Item -16), Page 4-109 (Item -17), Page 4-123 (Item -17), Page 4- | Supply of 11 KV, 2000A, Bus-Coupler Panel with Bus Riser including 2500A Bus, 11 KV CT, Numerical Relay and all other accessories as required. All circuit breaker's control with Local/ Remote switch and metering data shall be brought under Substation Automation System (SAS) and is to be interfaced with the existing/future NESCO's SCADA system. CT Ratio: 900-1800/5-5 A, 0.2S (1 nos), 5P30 (1 Nos) PT Ratio: 11000/√3:110/√3:110/√3 V | Supply of 11 KV, 2000A, Bus-Coupler Panel with Bus Riser including 2500A Bus, 11 KV CT, Numerical relay and all other accessories as required. All circuit breaker's control with Local/ Remote switch and metering data shall be brought under Substation Automation System (SAS) and is to be interfaced with the GE SCADA System Software. CT Ratio: 900-1800/5-5 A, 0.2S (1 nos), 5P30 (1 Nos), Short Circuit Current Capacity: 31.5 kA for 3 sec and IAC AFLR 31.5 KA for 1 Sec. (As per Scope/Brief Description of |

02

01

| Sr. No. | Reference | Original Clause/Sub-Clause | Amended Clause/Sub-Clause/Item |
|---------|--|---|--|
| | <p>140(Item -17), Page 4-153(Item -17), Page 4-170 (Item -16), Page 4-185 (Item -16), Page 4-204 (Item -16), Page 4-218 (Item -16), Page 4-236 (Item -16), Page 4-250 (Item -16), Page 4-268 (Item -17), Page 4-284 (Item -17) & Section 6-BOQ of all substations- Sub Clause- 1.2.1 (SL-16), 1.2.2 (SL-16), 1.2.3 (SL-16), 1.2.4 (SL-17), 1.2.5 (SL-17), 1.2.6 (SL-16), 1.2.7 (SL-16), 1.2.8 (SL-16), 1.2.9 (SL-17)</p> | <p>0.2 and 3P Short Circuit Current Capacity: 31.5 kA for 3 sec and IAC AFLR 31.5 KA for 1 Sec (As per Scope of Works, Technical Specification, GTP & SLD).</p> | <p>Works, Technical Specification and GTP).</p> |
| 12. | <p>Section 6-Sub Clause-2.1.5.2 (11 KV Transformer Incoming Cubicles)- Item No [13] (Page:6-184)</p> | <p>20/26.66 MVA Power Transformer: Single Phase Bushing/Ring type Current Transformer with Ratio 900-1800/5-5-5A power transformer of burden & accuracy class-20 VA & 0.2 (for measurement) and 20VA & 5P20 (for protection). (Characteristics: Epoxy resins insulated and double windings, butyl rubber type. The epoxy resin should be ultraviolet stabilized, fungus resistant & high tracking resistance, short time current ratings 31.5KA for 3 second & extended current ratings 120% of the rated value, secondary double winding, installation shall be in the panel).</p> | <p>Single Phase Bushing/Ring type Current Transformer with Ratio 900-1800/5-5-5A power transformer of burden & accuracy class-20 VA & 0.2S (for measurement) and 20VA & 5P30 (for protection). (Characteristics: Epoxy resins insulated and double windings, butyl rubber type. The epoxy resin should be ultraviolet stabilized, fungus resistant & high tracking resistance, short time current ratings 31.5KA for 3 second & extended current ratings 120% of the rated value, secondary double winding, installation shall be in the panel).</p> |
| 13. | <p>Section 6-Sub Clause-2.1.5.3 (Bus coupler with Bus riser cubicles)- Item No [13], (Page:6-186)</p> | <p>20/26.66 MVA Power Transformer: Single Phase Bushing/Ring type Current Transformer with Ratio 900-1800/5-5-5A power transformer of burden & accuracy class-20 VA & 0.2 (for measurement) and 20VA & 5P20 (for protection).(Characteristics: Epoxy resins insulated and double windings, butyl rubber type. The epoxy resin should be ultraviolet stabilized, fungus resistant & high tracking resistance, short time current ratings 31.5 KA for 3 second & extended current ratings 120% of the rated value, secondary double winding, installation shall be in the panel).</p> | <p>Single Phase Bushing/Ring type Current Transformer with Ratio 900-1800/5-5 A power transformer of burden & accuracy class-20 VA & 0.2S (for measurement) and 20VA & 5P30 (for protection). (Characteristics: Epoxy resins insulated and double windings, butyl rubber type. The epoxy resin should be ultraviolet stabilized, fungus resistant & high tracking resistance, short time current ratings 31.5 KA for 3 second & extended current ratings 120% of the rated value, secondary double winding, installation shall be in the panel).</p> |

Or

D'

| Sr. No. | Reference | Original Clause/Sub-Clause | Amended Clause/Sub-Clause/Item |
|---------|--|---|--|
| 14. | Section 6-Sub Clause-2.1.5.4 (11 KV Outgoing Circuit breaker Cubicles)-Item no[13] (Page:6-188) | Single Phase Bushing/Ring type Current Transformer of Ratio 600-300/5-5A of burden & accuracy class-15VA & 0.2 (for measurement) and 15VA & 5P20 (for protection).(Characteristics: Epoxy resins insulated and double windings, butyl rubber type. The epoxy resin should be ultraviolet stabilized, fungus resistant & high tracking resistance, short time current ratings 31.5 KA for 3 sec. & extended current ratings 120% of the rated value, secondary double winding, installation shall be in the panel) | Single Phase Bushing/Ring type Current Transformer of Ratio 600-300/5-5A of burden & accuracy class-15VA & 0.2S (for measurement) and 15VA & 5P30 (for protection).(Characteristics: Epoxy resins insulated and double windings, butyl rubber type. The epoxy resin should be ultraviolet stabilized, fungus resistant & high tracking resistance, short time current ratings 31.5 KA for 3 sec. & extended current ratings 120% of the rated value, secondary double winding, installation shall be in the panel) |
| 15. | Section 6-Sub Clause-2.4.11 (Guaranteed Technical Particulars of 11 KV Indoor Bushing/ Ring Type Single Phase Current Transformer for 11 KV AIS Switchgear Panel) , Item no. [13], (Page:6-450) | Accuracy class a) for measurement- 0.2 | Accuracy class a) for measurement- 0.2S |
| 16. | Section 6: Sub clause- 2.1.5.9 (Energy Meters) (Page:6-192) | All the energy meter shall be supplied from any of the following manufacturers or their equivalent:- a) Siemens, Germany/Switzerland. b) AEG, Germany. c) ABB, Switzerland/Finland d) Itron, USA e) Elster, USA./Romania f) Landis+ Gyr, Switzerland g) Toshiba (Japan) h) Honeywell (USA) i) CEWE, UK | All the energy meter shall be supplied from any of the following manufacturers or their equivalent:- a)Siemens, Germany/Switzerland. b) AEG, Germany. c) ABB, Switzerland/Finland d) Itron, USA e) Elster, USA/Romania f) Landis+ Gyr, Switzerland g) Toshiba (Japan) h) Honeywell (USA) i) CEWE, UK/Italy |
| 17. | Section 6: Sub clause- 2.2.1 (TEST REPORT ON 33 KV AIS SWITCHGEAR) (Page:6-405) | Manufacturer's authorization for Protective Relays from ABB (Switzerland/ Sweden/Finland) or Siemens (Germany) or Schneider Electric (UK/France) or ALSTOM (UK/France), SEL, USA & Energy Meters from Siemens (Germany/Switzerland) or AEG (Germany) or ABB (Switzerland/Finland) or Itron (USA) or Elster (USA/Romania) or Landis+ Gyr (Switzerland/Greece) or Toshiba (Japan) or Honeywell (USA) or CEWE (UK) or its equivalent in prescribed Form (PG5A-5). | Manufacturer's authorization for Protective Relays from ABB (Switzerland/ Sweden/Finland) or Siemens (Germany) or Schneider Electric (UK/France) or ALSTOM (UK/France), SEL, USA & Energy Meters from Siemens (Germany/Switzerland) or AEG (Germany) or ABB (Switzerland/Finland) or Itron (USA) or Elster (USA/Romania) or Landis+ Gyr (Switzerland/Greece) or Toshiba (Japan) or Honeywell (USA) or CEWE (UK/Italy) or its equivalent in prescribed Form (PG5A-5). |
| 18. | Section 6- Sub clause- 2.4.2 (GUARANTEED TECHNICAL | Manufacture's Name & Country: Siemens (Germany/Switzerland)/ AEG (Germany) / ABB | Manufacture's Name & Country: Siemens(Germany/Switzerland)/ AEG (Germany) / ABB (Switzerland)/ Toshiba (JAPAN) /Elster (USA |

On

J

| Sr. No. | Reference | Original Clause/Sub-Clause | Amended Clause/Sub-Clause/Item |
|---------|---|---|---|
| | PARTICULARS FOR 33 KV PROTECTION-CONTROL AND METERING PANEL) (SL No: 34.1) | (Switzerland)/ Toshiba (JAPAN) /Elster (USA /Romania), Landis+ Gyr (Switzerland/Greece)/ Honeywell (USA)/ CEWE (UK) or it's equivalent | /Romania), Landis+ Gyr (Switzerland/Greece)/ Honeywell (USA)/ CEWE (UK/Italy) or it's equivalent |
| 19. | Section 6: Sub Clause-2.1.5.4 (11 KV Outgoing Circuit breaker Cubicles)-Item no[14] (Page:6-188) | Numerical programmable IDMT & Instantaneous type Over Current and Earth fault protection relay with all necessary features for 11KV Outgoing feeder protection. The current setting range of the O/C & E/F relay shall be from $0.1 \cdot I_n$ to $40 \cdot I_n$ (where I_n is relay nominal current) for both overcurrent and earth fault element. All O/C & E/F relays shall have both IDMT, DT (51) and Instantaneous (50) function along with IEC NI, VI, EI, LTI etc. curve setting capability. The Relay must have at least 16 Nos BI and 8 Nos BO with (annunciator signal and Led signal reset) connection for SAS/SCADA ready. | Numerical programmable IDMT & Instantaneous type Over Current and Earth fault protection relay with all necessary features for 11KV Outgoing feeder protection. The current setting range of the O/C & E/F relay shall be from $0.1 \cdot I_n$ to $40 \cdot I_n$ (where I_n is relay nominal current) for both overcurrent and earth fault element. All O/C & E/F relays shall have both IDMT, DT (51) and Instantaneous (50) function along with IEC NI, VI, EI, LTI etc. curve setting capability. The Relay must have at least 16 Nos BI and 10 Nos BO with (annunciator signal and Led signal reset) connection for SAS/SCADA ready. |
| 20. | Section 6-Sub clause- 2.4.63 (Guaranteed Technical Particulars of Desktop computer with UPS) , SL No. [22] (Page: 6-543) | Sample: Should be submitted during evaluation process- 1Nos (Refundable) | Deleted. |
| 21. | Section 6-Sub clause- 1.1.2 (SL-19), 1.1.3 (SL-19), 1.1.4 (SL-19), 1.1.5 (SL-19), 1.1.6 (SL-19), 1.1.7 (SL-22), 1.1.8 (SL-19), 1.1.9 (SL-19), 1.1.10 (SL-20) (Civil & Building Works) | Painting (Weather Coat) of the whole Control room building is included in the scope. | Painting of the entire control room building is included in the scope of work, comprising weather coat for all exterior surfaces and plastic emulsion paint for all interior surfaces. |
| 22. | Section 6 Sub clause- 1.1.5 (B. Sub-station/Electrical Works), SL No.[30], Page-6-40 | Supply and installation of 04 (Four) Sets 33 kV Isolator (1600 A, 31.5 KA, for 3 Sec.) without earthing blade gang operated vertical mounted vertical break (4 Sets) and Horizontal mounted Horizontal break (1 Set) with supporting steel structure with necessary connectors and accessories. 03 (Three) Sets for Line Feeder & 1 (One) Set for Transformer Feeder. | Supply and installation of 05 (Five) Sets 33 kV Isolator (1600 A, 31.5 KA, for 3 Sec.) without earthing blade gang operated Isolator. Vertical mounted vertical break (4 Sets) and Horizontal mounted Horizontal break (1 Set) with supporting steel structure with necessary connectors and accessories. Among 04 sets Vertical mounted vertical break isolator 03 (Three) Sets for Line Feeder & 1 (One) Set for Transformer Feeder |
| 23. | Section 6- | Renovation of control room building (i.e. Sanitation, Patten stone as per | Renovation of control room building (i.e. Sanitation, Patten stone as per |

On

2

| Sr. No. | Reference | Original Clause/Sub-Clause | Amended Clause/Sub-Clause/Item |
|---------|--|---|--|
| | Sub clause- 1.1.10 (A. Civil & Building Works), SL No.[7], Page-6-82 | site requirements, Electrical Rewiring, False Ceiling, Complete Control Room Tiles & etc.) as per requirements. In control room, high quality tiles shall be installed in floor. | site requirements, Electrical Rewiring, False Ceiling, Complete Control Room Tiles & etc.) including removal of the door of the current battery room from the west side and relocation to the north side as per requirements. In the control room, high quality tiles shall be installed on the floor. |
| 24. | Section 6- Employer's Requirements- GUARANTEED TECHNICAL PARTICULARS for Laser Printer, Item No. [2.4.65] | None | See Annexure-1 to this Bid Bulletin No. 2, which shall form part of Chapter 6 – Guaranteed Technical Particulars of Section 6 – Employer's Requirements. |
| 25. | Section 6- Employer's Requirements- Sub Clause- 2.1.29.8 (Capitalized Cost) (Page 6-263) | e = Energy Cost, Tk. 6.00/KWh | e =Average Billing Rate, Tk 9.07/KWh |
| 26. | Section 6- Sub Clause- 2.4.30 (GUARANTEED TECHNICAL PARTICULARS FOR SINGLE-CORE, 150 MM2 HARD DRAWN BARE COPPER CONDUCTOR FOR GROUNDING SYSTEM), Page-6- 501 | GUARANTEED TECHNICAL PARTICULARS FOR SINGLE-CORE, 150 MM2 HARD DRAWN BARE COPPER CONDUCTOR FOR GROUNDING SYSTEM | See Annexure-2 to this Bid Bulletin No. 2. |
| 27. | Attachment-1 | Single Line Diagram of 33/11 KV Sub-Station, Fakirpara, Dinajpur | See Annexure-3 to this Bid Bulletin No. 2 for amended SLD of Attachment-1 |
| 28. | Attachment-4 | Single Line Diagram of 33/11 KV Sub-Station, Setabgonj, Dinajpur | See Annexure-3 to this Bid Bulletin No. 2 for amended SLD of Attachment-4 |
| 29. | Attachment-5 | Single Line Diagram of 33/11 KV Sub-Station, Panchagarh | See Annexure-3 to this Bid Bulletin No. 2 for amended SLD of Attachment-5 |
| 30. | Attachment-9 | Single Line Diagram of 33/11 KV Sub-Station, Golahat, Saiyadpur | See Annexure-3 to this Bid Bulletin No. 2 for amended SLD of Attachment-9 |
| 31. | Attachment-10 | Single Line Diagram of 33/11 KV Sub-Station, Niyamotpur, Saiyadpur | See Annexure-3 to this Bid Bulletin No. 2 for amended SLD of Attachment-10 |
| 32. | Section 6-Clause-3-ENVIRONMENT, HEALTH AND SAFETY MANAGEMENT REQUIREMENT (page 6-546) | The Contractor shall ensure that all works follow the requirements of the Site Clearance Certificate and project EMP as attached. Corrective Action Plan (CAP) for existing facilities (substations) to be implemented by NESCO pre-construction unless delegated to the contractor as part of their contractual obligations, as follows. The short-term actions are to be completed prior to the start of any other works under the contract | See Annexure-4 to this Bid Bulletin No. 2 |

On

D

| Sr. No. | Reference | Original Clause/Sub-Clause | Amended Clause/Sub-Clause/Item |
|---------|--|---|--|
| | | <p>whilst the long-term actions are to be completed prior to commissioning with a handover to the substation manager on completion who will be responsible for compliance during operation and maintenance:</p> <p>CAP will be added later as addendum.</p> | |
| 33. | Section 8- Clause-47 (Environment Management Plan) Page 8-13 | <p>47.1 The Contractor shall comply with all applicable national and local environmental laws and regulations.</p> <p>The Contractor shall (a) establish an operational system for managing environmental impacts, (b) carry out all of the monitoring and mitigation measures set forth in the Environmental Management Plan ("EMP") and (c) allocate the budget required to ensure that such measures are carried out. The Contractor shall submit semi-annual <u>monthly</u> reports on the carrying out of such measures to the Employer.</p> <p>More particularly, the Contractor shall comply with (i) the environmental management plan attached hereto <u>in section 6 as Appendix [I,II]</u>; and (ii) any corrective or preventative actions set out in safeguards monitoring reports that the Employer will prepare from time to time to monitor implementation.</p> <p>The Contractor shall allocate a budget for compliance with these measures, requirements and actions.</p> <p>Appendix to SCC will be provided (in PDF form as Appendix- I and II) with the bidding document:</p> <p>Environment Management Plan (EMP) Corrective Action Plan (CAP) if any</p> | <p>47. Environment Management Plan</p> <p>47.1 The Contractor shall comply with all applicable national and local environmental laws and regulations.</p> <p>47.2 The Contractor shall comply with the Employer's project financier's environmental safeguard requirements [ADB's Safeguard Policy Statement (2009) including the International Finance Corporation's Environmental Health and Safety General Guidelines and guidelines on Electric Power Transmission and Distribution and the International Labor Organization's Safety and Health in Construction guidelines]. More particularly, the Contractor shall comply with (i) the measures and requirements set forth in the initial environmental examination and the environmental management plan, draft attached hereto as Annexure-5 to this Bid Bulletin No. 2; and (ii) any corrective or preventative actions set out in safeguards monitoring reports that the Employer will prepare from time to time to monitor implementation of the initial environmental examination and the environmental management plan. The definitive (final) version of the IEE and EMP to be complied with by the Contractor will be the version that is disclosed on the Employer's project financier's [ADB] website. The Contractor shall allocate a budget for compliance with these measures, requirements and actions.</p> <p>47.3 The Contractor shall (a) establish an operational system for managing environmental impacts, (b) carry out all the monitoring and mitigation measures assigned to them as set forth in the Initial Environmental Examination ("IEE") and Environmental Management Plan ("EMP") including subsequent updates to them, (c) allocate the budget and staff resources required to ensure that such measures are carried out, and implement any corrective actions required by the Employer, and (d) cover the cost of corrective action</p> |

| Sr. No. | Reference | Original Clause/Sub-Clause | Amended Clause/Sub-Clause/Item |
|---------|-----------|----------------------------|--|
| | | | <p>required in response to non-compliance with the definitive version of the EMP or property damage caused by the Contractor, subcontractors and third parties employed by them. The Contractor shall submit monthly reports on the carrying out of such measures to the Employer. The Contractor shall ensure mitigation measures are implemented at all construction sites as well as at any workers' camps or overnight accommodation provided by them or their subcontractors.</p> <p>47.4 The Contractor shall not commence any "Physical Works" including site establishment (i) the Contractor has obtained all required environment, health and safety (labor) permits or licenses, (ii) the Contractor has undertaken and reported to the Employer on the findings of all applicable pre-construction environmental survey work and baseline environmental monitoring requirements as set out in the definitive version of the EMP, (iii) the Contractor has incorporated all the applicable requirements of the definitive version of the EMP into their detailed designs; (iv) the Contractor has submitted the detailed designs and as part of the SSEMP and SSHSMP all environmental, health and safety sub-plans required by the definitive version of the EMP and received written confirmation from the Employer of their approval.</p> <p>47.5 The Contractor shall ensure that all its design and construction staff, as well as the staff of subcontractors and third-parties employed by them, regardless they are formally or informally contracted, understand their responsibilities to implement the EMP with appropriate environment, health and safety (EHS) training being provided by the Contractor including construction-site EHS inductions, emergency procedure drills, monthly refresher trainings, and daily toolbox talks. The Contractor shall ensure all construction staff, including the staff of subcontractors and third-parties employed by them, have attended the necessary specialized, task-specific training and are medically fit to perform their role.</p> <p>47.6 The Contractor shall establish an operational system for managing and monitoring environmental, health and safety impacts and risks, progress with implementation, and compliance to the</p> |

02

Dr

| Sr. No. | Reference | Original Clause/Sub-Clause | Amended Clause/Sub-Clause/Item |
|---------|-----------|----------------------------|--|
| | | | <p>definitive version of the EMP requirements. The Contractor's management and EHS staff will attend monthly EHS meetings convened by the Employer and submit monthly reports on EMP progress and compliance to the Employer documenting the mitigation measures and monitoring activities carried out, issues encountered including statistics and details of all near misses and accidents, grievances received, and follow-up actions that were taken (or will be taken) to correct any issues.</p> <p>47.7 In case of (i) an unanticipated impact not considered in the IEE, including changes to the scope of works during detailed design, to enable the Employer to update the IEE and EMP for clearance by their project financier [ADB] before any changes are implemented, or (ii) non-compliance with the definitive version of the EMP the Contractor will inform the "Employer" in writing and implement corrective actions agreed.</p> <p>47.8 In case of a chance find or any pollution or health and safety incident including near misses the Contractor will inform the "Employer" within 24 hours with details of the incident and the corrective action being taken. The "Employer" is required to inform the project financier of any fatality within 48 hours of its occurrence along with a copy of the contractor's incident report and corrective action plan, so the Contractor will ensure submission in a timely manner.</p> <p>47.9 The Employer may withhold payment if monthly reports are not submitted within 5 working days of month end or in the event corrective actions required by the Employer have not been addressed by the Contractor within 30 days.</p> |

The amended clause/sub-clause or item shall replace the provision(s) in the issued Bidding Document. All other terms & conditions shall remain unchanged.

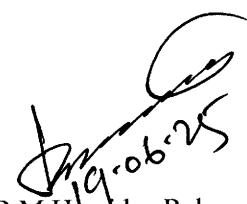

(Engr. A B M Hamidur Rahman)
Project Co-ordinator

Network Infrastructure Development and
Modernization of Distribution System in NESCO area.

Annexure- 1

2.4.65 Guaranteed Technical Particulars for Laser Printer

(To be filled up by the Manufacturer in the manufacturer's Letterhead Pad with appropriate data, otherwise Bid shall be rejected.

| SL. No. | Description | NESCO's Requirement | Bidder's Particulars |
|---------|--------------------------|--|----------------------|
| 1 | Name of the Item | Laser Printer | |
| 2 | Brand | Any International Reputed Brand | |
| 3 | Model | To be mentioned (should be available in Retail Market) | |
| 4 | Country of origin | To be mentioned | |
| 5 | Print Technology | Laser | |
| 6 | Processor Speed | Min. 800 MHz | |
| 7 | Display | 2 line back lit LCD graphic display | |
| 8 | Resolution | Minimum 1200 X 1200 dpi | |
| 9 | Duty Cycle (monthly) | Minimum 80,000 pages per month | |
| 10 | Print Speed | Minimum 40 PPM (letter/A4) | |
| 11 | Duplex Print | Automatic | |
| 12 | Memory | Minimum 256 MB | |
| 13 | First Print Out Time | Less than 7.5 seconds (From Ready Mode) | |
| 14 | In Box Toner | Minimum 3000 pages | |
| 15 | Toner Cartridge | Model to be mentioned | |
| 16 | Interface | USB, LAN, WiFi | |
| 17 | Paper Type | Plain / Thin / Thick / Thicker / Cardstock / Transparency / Pre-Printed/Recycled / Archive / Bond / Label / Envelope / Thick Envelope / Cotton / Colored | |
| 18 | Paper Handling | Min 250 Sheets Standard Paper Tray and 50 Sheet Multipurpose Tray Output Tray min 150 sheets | |
| 19 | Paper Size | A4, Letter, Legal, Executive / Folio /Envelope | |
| 20 | Operating System Support | Windows 7, 8, 10 and 11; Android | |
| 21 | Power Consumption | Not more than 500W(active printing) | |



Annexure- 2

2.4.30 GUARANTEED TECHNICAL PARTICULARS FOR SINGLE-CORE, 150 MM² HARD DRAWN BARE COPPER CONDUCTOR FOR GROUNDING SYSTEM.

(To be filled up by the Manufacturer in Manufacturer's Letterhead Pad, otherwise the bid shall be rejected)

| Sl. No. | Description | Unit | Purchaser's Requirement | Manufacturer's Particulars |
|---------|---|----------------------|--|----------------------------|
| 1 | Name of the Item | | 1CX150 sq. mm Hard Drawn bare copper stranded conductor | |
| 2 | Name of the Manufacturer | | Shall be mentioned | |
| 3 | Address of the Manufacturer | | Shall be mentioned | |
| 4 | Standard | | To be mentioned | |
| 5 | Cable Size | mm ² | 1CX150 | |
| 6 | Material | | High Conductive | |
| 7 | Numbers & Diameter of wires | mm | Min 37 Wires/2.35 (Before stranding) | |
| 8 | Wire Diameter Tolerance | mm | ±0.05 | |
| 9 | Maximum DC resistance at 20 deg. C | Ω/KM | 0.1233 | |
| 10 | Approximate outer diameter (Nominal) | mm | 14.44 to 15.4 | |
| 11 | Approximate weight | Kg/KM | 1335 | |
| 12 | Continuous permissible service voltage | V | 600/1000 | |
| 13 | Volume Resistivity of Copper Conductor at 20°C | Ω-mm ² /m | To be Mentioned with name of related standard | |
| 14 | Conductivity of Copper Conductor at 20°C | % (IACS) | 97 (Min.m) | |
| 15 | Current rating at 30 deg. C ambient temperature U/G | Amps | Shall be mentioned | |
| 16 | Current rating at 35 deg. C ambient in air | Amps | Shall be mentioned | |
| 17 | Drum wound length | M | 500/1000 | |
| 18 | Net Weight | Kg | Shall be mentioned | |
| 19 | Gross weight | Kg | Shall be mentioned | |
| 20 | Minimum Breaking Load | N | Shall be mentioned | |
| 21 | Lay Ratio of Different Layer | - | Shall be mentioned | |
| 22 | Treated Wooden Drum Standard | | Shall be mentioned the name of used latest international standards | |

Annexure 3

Om

Dr.

PANCHAGARH

ATTACHMENT-05

SUBSTATION: PANCHAGARH

LEGEND
 EXISTING SUBSTATION (BLACK COLOR)
 TO BE REMOVED (RED COLOR)
 TO BE REPLACED (PINK COLOR)
 NEW PORTION (GREEN COLOR)
 TO BE RELOCATE (BLUE COLOUR)

| LEGEND | |
|--------|------------------------------|
| | LIGHTING ARRESTOR |
| | ISOLATOR WITHOUT EARTH BLADE |
| | ISOLATOR WITH EARTH BLADE |
| | CURRENT TRANSFORMER |
| | 33kV VCB |
| | 12kV INDOOR VCB |
| | FUSE |
| | POTENTIAL TRANSFORMER |
| | POWER TRANSFORMER |

PROPOSED SWITCHGEAR EQUIPMENT

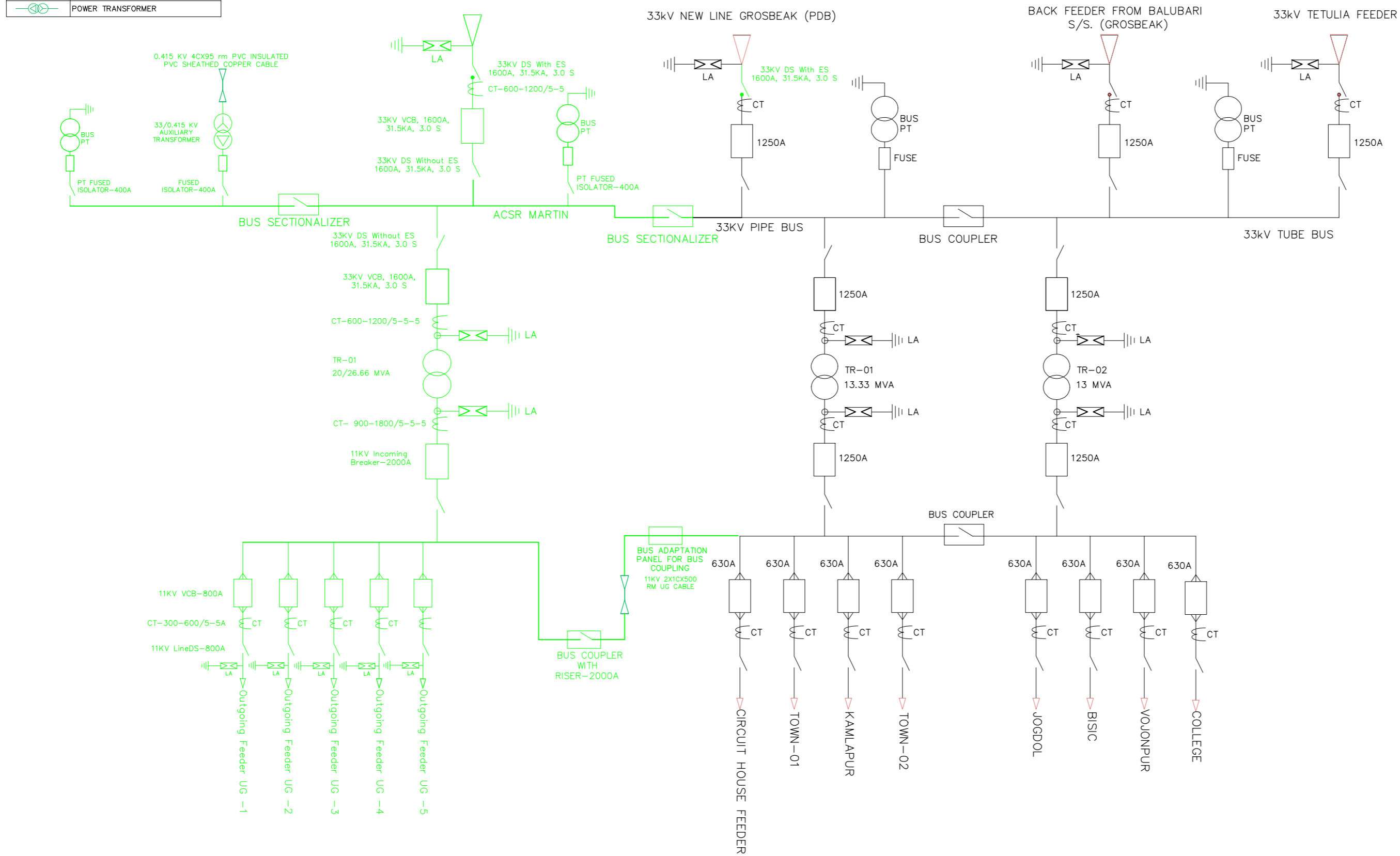

NORTHERN ELECTRICITY SUPPLY COMPANY (NESCO)
**SINGLE LINE DIAGRAM OF
 33/11 kV SUB-STATION, PANCHAGARH**

0.2m

0.2m

ATTACHMENT-09

SUBSTATION: GOLAHAT

LEGEND
 EXISTING SUBSTATION (BLACK COLOR)
 TO BE REMOVED (RED COLOR)
 TO BE REPLACED (PINK COLOR)
 NEW PORTION (GREEN COLOR)
 TO BE RELOCATE (BLUE COLOUR)

PROPOSED SWITCHGEAR EQUIPMENT

EXISTING SWITCHGEAR EQUIPMENT

GOLAHAT

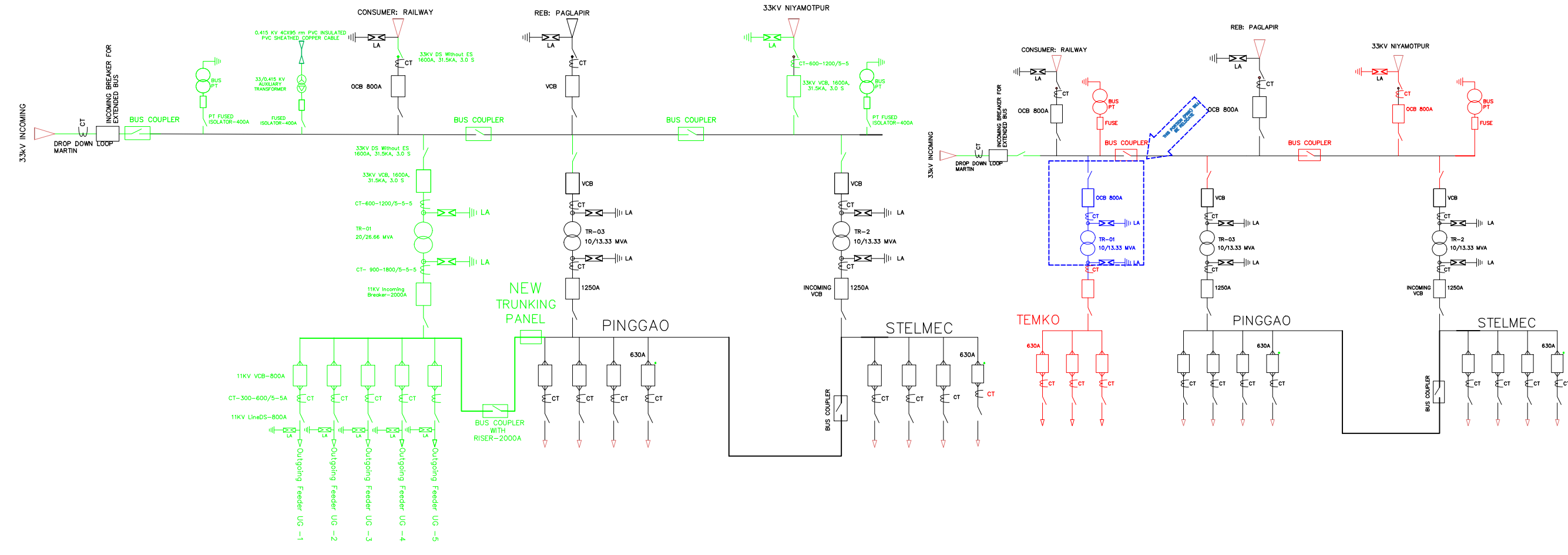

LEGEND

| | |
|--|------------------------------|
| | LIGHTING ARRESTOR |
| | ISOLATOR WITHOUT EARTH BLADE |
| | ISOLATOR WITH EARTH BLADE |
| | CURRENT TRANSFORMER |
| | 33kV VCB |
| | 12kV INDOOR VCB |
| | FUSE |
| | POTENTIAL TRANSFORMER |
| | POWER TRANSFORMER |

NORTHERN ELECTRICITY SUPPLY COMPANY (NESCO)
SINGLE LINE DIAGRAM OF
33/11 kV SUB-STATION, GOLAHAT, SAIYADPUR

[Handwritten mark]

[Handwritten signature]

NIYAMOTPUR

ATTACHMENT-10

SUBSTATION: NIYAMOTPUR

LEGEND

- EXISTING SUBSTATION (BLACK COLOR)
- TO BE REMOVED (RED COLOR)
- TO BE REPLACED (PINK COLOR)
- NEW PORTION (GREEN COLOR)
- TO BE RELOCATE (BLUE COLOUR)

EXISTING SWITCHGEAR EQUIPMENT

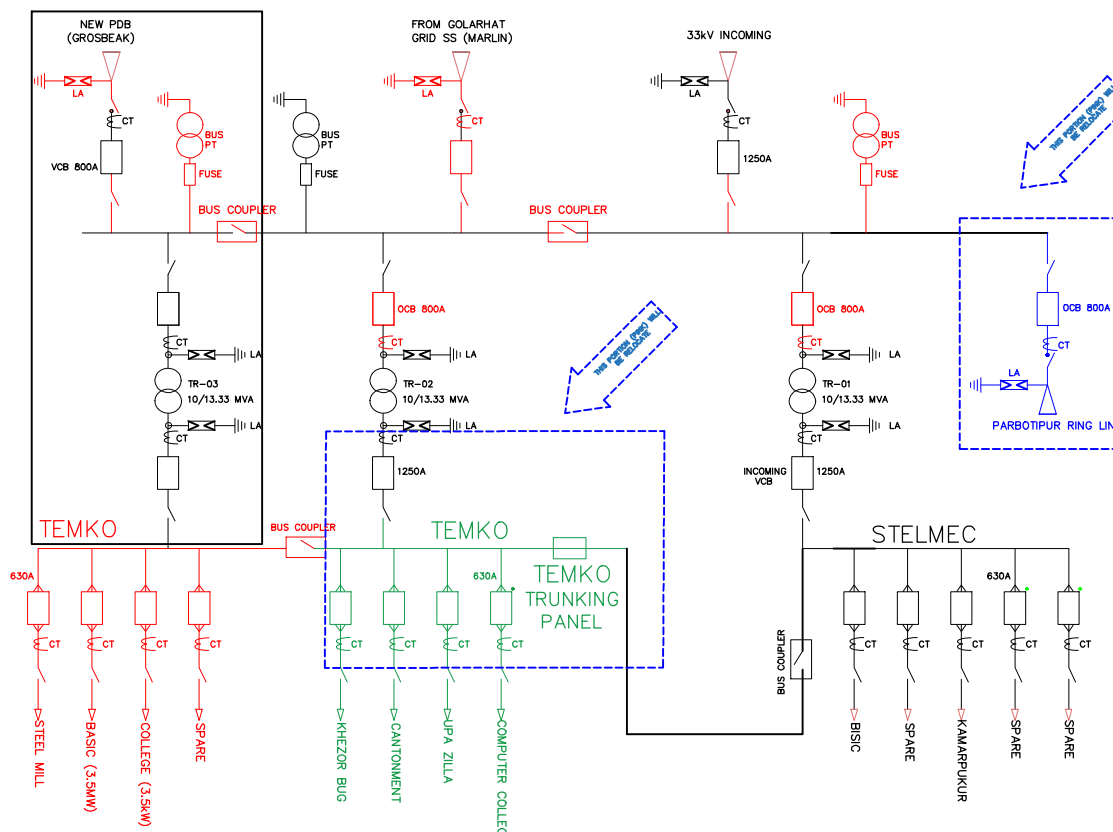

PROPOSED SWITCHGEAR EQUIPMENT

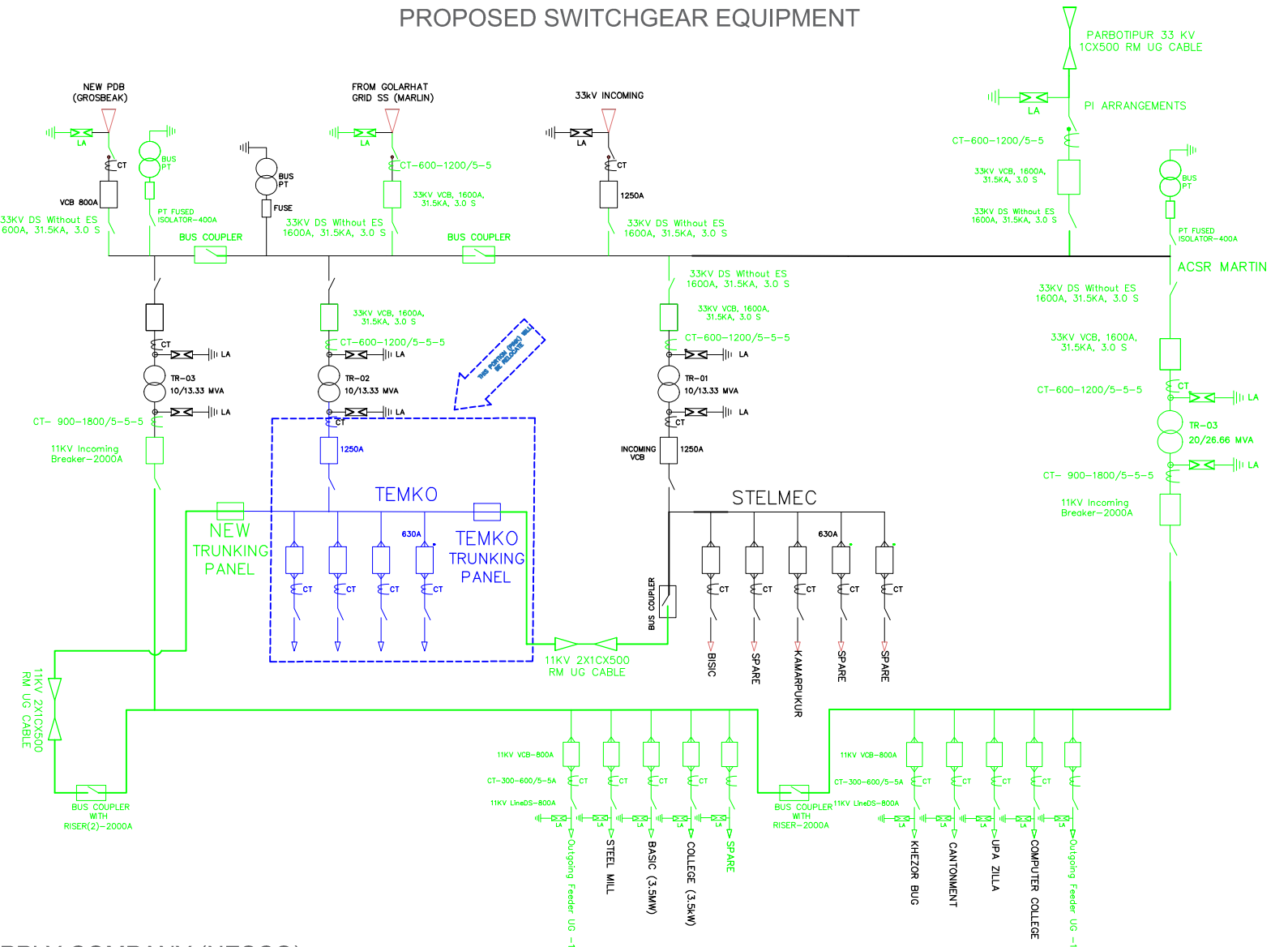

LEGEND

- | | |
|--|------------------------------|
| | LIGHTING ARRESTOR |
| | ISOLATOR WITHOUT EARTH BLADE |
| | ISOLATOR WITH EARTH BLADE |
| | CURRENT TRANSFORMER |
| | 33kV VCB |
| | 12kV INDOOR VCB |
| | FUSE |
| | POTENTIAL TRANSFORMER |
| | POWER TRANSFORMER |

NORTHERN ELECTRICITY SUPPLY COMPANY (NESCO)
**SINGLE LINE DIAGRAM OF
 33/11 kV SUB-STATION, NIYAMOTPUR, SAIYADPUR**

Handwritten signatures and initials at the bottom of the page.

Annexure- 4

Environment, Health and Safety Management Requirements

The Contractor shall ensure that all works follow the requirements of the project EMP as attached as Annexure-5 to this Bid Bulletin No. 2.

Corrective Action Plan (CAP) for existing facilities (substations) to be implemented by NESCO pre-construction unless delegated to the contractor as part of their contractual obligations, as follows. The short-term actions are to be completed prior to the start of any other works under the contract whilst the long-term actions are to be completed prior to commissioning with a handover to the substation manager on completion who will be responsible for compliance during operation and maintenance:

Short Term Actions:

- 1) Ensure good housekeeping at all substations.
- 2) Tidy up the substation ensuring all materials and wastes including cables, broken electrical systems, meters, glass and plastic, oils etc. are collected up, segregated, and stored in the designated and labelled storage areas.
- 3) Prohibit any open burning of waste at the substation site.
- 4) Demark labelled storage areas for materials and segregated waste; storage should be in a locked area, under cover to provide shelter from the elements, having fully enclosed garbage bins for the disposal of municipal solid waste, and where liquids or leachable materials are stored having an impermeable floor bunded to 110% capacity of the volume that is stored.
- 5) If impermeable floor bunded to 110% capacity is not available in the short-term and while storage areas are brought into compliance, liquid and leachable materials/waste to be kept on drip trays to provide secondary containment.
- 6) Remove (and prohibit any further) end-of-life equipment or waste stored outside the substation boundary relocating it to designated and labelled storage areas within the substation.
- 7) Ensure no defunct/material storage outside substation area.
- 8) Remove all other waste that has built up on substation site by appropriately licensed waste management company with all storage, transport, and disposal as per national regulations and in an environmentally safe and sound manner whilst following the waste hierarchy.
- 9) Filled drums (mineral oil) are all to be sealed and labelled with their contents with safety warnings.
- 10) MSDS to be available at the SS site for all the materials used on site.
- 11) Collect up and store empty and filled drums (mineral oil) in a locked, under cover, designated storage area, they should either be stored on an impermeable floor bunded to 110% capacity of volume stored, or if not available in the short-term kept on drip trays to provide secondary containment while the storage area is brought into compliance
- 12) Defunct transformers prior to being removed from site are to be placed in a designated storage area, they should either be stored on an impermeable floor bunded to 110% capacity of volume stored, or if not available in the short-term and while the storage area is brought into compliance kept on drip trays to provide secondary containment
- 13) In conjunction with the substation manager, inventory to be prepared of existing transformers on site, make, model, risk of PCBs (conducting PBC test if required) and other details including transformer test report, details any maintenance works undertaken, dates oil changes, leakage incidents etc.
- 14) Carry out inspections and preventive maintenance of existing transformers to minimize oil leakages; ensure valves, nuts and bolts are fully functional and tightly secured, ensure rubber seals of radiators are intact.
- 15) Existing transformers in a poor state of repair and which are currently leaking oil to be maintained/repared so they are left in good condition.
- 16) Health and safety risk assessment for exposure of substation staff (and contractor's workers) to PCBs to be undertaken before maintenance/repair work is undertaken on any existing SS transformers.
- 17) Clean up all existing oil spill, excavate any contaminated soil and send for disposal (as hazardous waste) using appropriately licensed waste management company with all storage, transport, and disposal as per national regulations and in an environmentally safe and sound manner
- 18) Make available spill management materials (sorbent pads, loose sorbent material, sand, etc.) next to the storage area for immediately soaking up any leaks or spills that do accidentally occur.



- 19) Provide sand buckets, full of sand, placed in a prominent, signed location near to fire-risk locations such as transformers and oil storage areas.
- 20) Provide eye wash station and water supply to shower located near the storage areas for fuel/oil/chemicals.
- 21) Make available fire extinguishers (including for oil and electric fires) in a prominent, signed location near to fire-risk locations such as transformers and oil storage areas with service and expiration dates clearly labelled.
- 22) Expired/exhausted fire extinguishers to be refilled/replaced.
- 23) Entire boundary to be well secured, existing boundary fence or wall to be installed/repaired/replaced ensuring no gaps for entry of people or livestock and that it is sufficiently high so that it cannot be climbed over.
- 24) Security persons are to be deployed at all substations for 24x7 period with rotation/shifts. Number of security guards is to be determined in consultation with NESCO based on the size/area of the substation and the adjacent land use.
- 25) Dedicated shelter to be provided at the site entrance for use by any security guards, shielding them from rain, wind, and extreme (hot and cold) temperatures.
- 26) All the electrical equipment at the substation to have visual and written warning signage including the ISO 7010 Hazard Type: Electrical Symbol warning of the risk of electrocution.
- 27) Safety signage with large and colorful display to be placed along boundary and at the gate with visual and written warning signages including the ISO 7010 Hazard Type: Electrical Symbol warning of the risk of electrocution. Safety sign to be placed to make local community aware that the substation site is out of bounds and a health and safety risk to them.
- 28) Keep clear all the emergency exits with signage, remove blockages due to storage of end-of-life equipment.
- 29) All potential trip and fall hazards need to be removed including repair of broken floor inside control rooms, cable drain tiles and covers, etc.
- 30) Noise levels at substations to be monitored and managed regularly as per EMP.
- 31) Defunct bulbs/lights to be replaced
- 32) Provide adequate natural and/or artificial lighting levels to meet the IFC EHS Guidelines on Occupational H&S (Table 2.3.3. Minimum Limits for Workplace Illumination Intensity) within control rooms, toilets, stairways, and other areas having regular staff movements.
- 33) Existing vents/windows to be unblocked to ensure adequate ventilation Provide first aid posters including first aid for electrocution incident and posters on fire safety.
- 34) Make available fully stocked, in-date first aid kit in a prominent, signed position at all substations.
- 35) Prominently post a list of doctors'/emergency health/fire station contacts. (names/locations/phone numbers) list in case of emergency
- 36) Establish and maintain an incident logbook.
- 37) Provide substation with potable drinking water supply meeting GoB and WHO drinking water standards.
- 38) Provide everyone who enters the substation with an OHS induction.
- 39) All staff at substation to be given required PPE and other requisite safety equipment.
- 40) Provide sufficient spares PPE available on site for visitors etc.
- 41) Carry out inspections and preventive maintenance to ensure electrical standards are upheld.
- 42) Employ third party to conduct pest control and safely remove existing pest hazards such as beehives where they are identified, pest control to be based on integrated pest management approaches and aim to reduce reliance on synthetic chemical pesticides especially those hazardous to human health and the environment, such as the use of carbolic acid as deterrent to snakes.
- 43) Fully enclosed bins for storage of food waste to be provided and food waste stored in them to avoid attracting rodents usually followed by snakes.
- 44) Structurally assess building stability and repair as required the damaged buildings due to earthquake ensuring that all buildings, especially for these in earthquake prone areas, are designed to applicable seismic standards.
- 45) Removal of all stagnant water e.g., rainwater that has accumulated in empty drums etc.
- 46) In damp/wet areas the surfaces are to be cleaned so algae (slipperiness) is not present and warning signs to be placed.
- 47) Defunct drainage to be repaired.
- 48) For all existing toilets ensure adequate lightening, repairing of door, locks, and latches provided (as they are shared access toilets for both male and female) as well as hand washing facilities with soap and water. Cleaning of existing toilets to be on daily basis, use of disinfectant and floor cleaners.

- 49) Ensure all sources of wastewater connected to septic tank with a soakaway for disposal of the septic tank wastewater, no untreated wastewater should be disposed of to surface water or ground.
- 50) Ensure that septic tanks and soak aways are well maintained.
- 51) For the welfare of substation staff during their shifts provide a dedicated cooking area / clean eating area / rest area for staff on-site that meets GoB and ILO worker accommodation requirements.
- 52) Maintain vegetation at the substation that poses a health and safety hazard e.g., because gaps/channels/broken covers are hidden due to vegetation growth or snakes may be hidden within the grass etc.

LONG TERM

- 1) In substations where a locked, under cover material and waste storage area with an impermeable floor bunded to 110% capacity of the volume stored are not available for the storage of fuel/oil/chemicals and solid/hazardous waste, construct such a storage area.
- 2) For those transformers confirmed as containing PCBs ensure these are dechlorinated or removed from site with storage, transport, and disposal as per national regulations and in an environmentally safe and sound manner.
- 3) In substations where bund of 110% capacity extending beyond the transformer footprint is not available in the short-term, retrofit such a bund to existing transformers.
- 4) Control panel and other equipment within control buildings to be rearranged and placed in a manner to maximize natural ventilation and light for those substations where the ventilation and light is being obstructed.
- 5) For switch yard lightning system to be improved so all areas are well-lit at night when required.
- 6) Ensure automatic fire alarm, fire suppression systems and firewalls installed.
- 7) Ensure a substation specific emergency preparedness plan is developed, in conjunction with the substation manager, including the communication system and protocols for response to a fire, earthquake, flood, medical emergency etc. and followed for substation operation with regular fire drills and alarm tests conducted (copy kept on site).
- 8) Ensure all substation workers receive basic first aid and firefighting training.
- 9) Ensure H&S risk assessment is completed, in conjunction with substation manager, for the substation operation and maintenance works undertaken and that appropriate H&S management actions identified (copy of risk assessment and the action plan to be kept on site)
- 10) Building structural status for substations – ensure building repairs are undertaken to maintain the integrity of control buildings especially in the event of an earthquake
- 11) Ensure substations have adequate storm water drainage to avoid damp and wet conditions/waterlogging during high rainfall.
- 12) Ensure substations adjacent to surface water streams/rivers have adequate flood protection (e.g., drainage channels, boundary walls, flood embankments of suitable design) in the event of high flows to prevent inundation and water entry within site
- 13) Provide on storm drainage oil-water separator on all drains.

The Contractor shall appoint at least one appropriately qualified and experienced, dedicated Environment Specialist who is an expert in pollution control (oil management) to be based full-time on site to support, supervise and monitor EMP implementation on a day-to-day basis for the duration of “Physical Works” under the contract and to also act as the community liaison, stakeholder engagement and grievance redress mechanism focal for the local community to keep the affected persons informed of works and be available to receive, document, and deal with any grievances at the project site level.

The Contractor shall employ suitably qualified and experienced third-party monitoring experts to carry out field tests and laboratory analysis required by the definitive version of the EMP in respect of environmental monitoring for air quality, noise, surface water and groundwater quality, and soil.

The Contractor shall appoint at least one appropriately qualified and experienced, dedicated Health and Safety Specialist with NEBOSH/IOSH certification or similar qualification, as well as one appropriately qualified and experienced, dedicated Labor Specialist, to both be based full-time on site to support, supervise and monitor EMP implementation with respect to health and safety (labor) on a day to day basis for the duration of “Physical Works” under the contract and also act as grievance redress mechanism focal for workers and in respect of occupational health and safety keep the affected persons

(workers) informed and be available to receive, document, and deal with any grievances at the project site level.

The Contractor will ensure that if multiple sites are operated at the same time each active construction site has adequate environment, health and safety supervision with a view to ensuring pollution control and waste management and the health and safety of all workers and local communities. This is to include suitably qualified and experienced Environment, Health and Safety Supervisors having NEBOSH/IOSH certification or similar qualification. The environment, health and safety supervisors to be dedicated, full-time presence at each active construction site (substation) with at least one for each team of up to 50 persons.

All subcontractors of the contractor will be required to appoint an EHS representative, who will be available on each work site at all times.

The Contractor will ensure no CFCs, no PCBs and no asbestos containing materials are used in the project, certification from the manufacturer will be provided that transformers are PCB free and vinyl tiles/cement board are asbestos free.

The Contractor will comply with the ADB Good Practice Guidance for the Management and Control of Asbestos: Protecting Workplaces and Communities from Asbestos Exposure Risks and employ a competent asbestos surveyor to conduct asbestos survey prior to any demolition works being carried out.

The Contractor will ensure no forced or child labor or persons under 18 are employed on the project.

The Contractor shall undertake a health and safety risk assessment and building on the EMP requirements the Contractor shall develop a SSEMP/Construction Environmental Management Plan and sub-plans, including a SSHSMP/Health and Safety Plan, incorporating emergency preparedness and response plans for approval of the Employer.

The contractor shall take all measures and precautions necessary to ensure the health, safety and welfare of all persons entitled to be on the site and will ensure that works are carried out in a safe and efficient manner. Such precautions shall include those that, in the opinion of the Employer, are reasonable to prevent unauthorized entry on the site and to protect members of the public from any activities under the control of the contractor.

The Contractor will carry out communicable disease awareness programs for labor, disseminate information at worksites on the risks of communicable vector borne and viral diseases, and provide adequate handwashing facilities and personal protective equipment, as part of health and safety measures for those employed during construction.

The Contractor shall provide and maintain a suitably equipped and staffed first aid station. First aid equipment and free access for workers to a qualified nurse and/or doctor must be provided. Ambulance for moving injured persons to the nearest hospital must also be provided in ready to move condition. First-aid kits must be available immediately at all work sites and shall contain an adequate supply of in-date sterilized dressings and bandages with other necessary first aid equipment as per national health and safety (labor) laws and regulations and the EMP requirements.

The Contractor shall provide and maintain all necessary temporary fire protection and firefighting facilities during the construction of the Works and shall comply with all national and state fire safety requirements. These facilities must include in-date, serviced, portable fire extinguishers suitable for fighting the potential hazards on the construction site.

The provision of lighting, including standby facilities in the event of failure that, in the opinion of the Employer, is adequate to ensure the safe execution of any works that are to be carried out in light.

The contractor is to ensure sufficient sanitation and welfare facilities (with all wastewater discharges connected to a sewerage system or septic tank with soakaway or self-contained portable toilets with disposal of the wastewater off-site) are available at each construction site and at any worker camps or accommodation provided by them or their subcontractors with a ratio of at least 1 toilet per every 6 persons. Open defecation and urination are prohibited. Use of pit latrines is prohibited, and no direct discharge of untreated wastewater to surface water or groundwater is allowed.

The contractor is to ensure any worker camps or overnight accommodation provided by them or their subcontractors complies with all national and state requirements as well as the ILO guidelines on worker accommodation.



If a local water source is to be used as drinking water supply it must be licensed for abstraction and be subject to adequate treatment to enable GoB and WHO drinking water standards to be maintained, the quality of raw and treated water to be tested regularly to confirm drinking water standards are met.

The Contractor shall ensure adequate collection, separation, and storage of inert, solid, and hazardous waste on site and safe transportation for recycling through reputable, legitimate, licensed third parties and/or to suitably licensed and engineered waste management facilities suitable for the type of waste, with all waste transfer records retained.

The Contractor shall put in place a prohibition on firewood collection, fishing, hunting, or poaching by construction staff, as well as the staff of subcontractors and third-parties employed by them, regardless they are formally or informally contracted and ensure adequate alternative fuel is provided at any worker camps or accommodation for cooking and heating purposes.

All equipment and machinery used during construction to be of modern design, maintained in good condition, and with secure and strong health and safety guards installed around moving parts and kept in use at all times. Fuel, oils and lubricants for operating equipment and machinery must be kept on the drip trays whilst in use on site.

Stack emissions of any temporary diesel generator set or similar to comply with national emission standards with the stack height design according to both GoB requirements and international good industry practice (as per IFC EHS General Guidelines).

The Contractor shall ensure that throughout "Physical Works" including site establishment and tree or vegetation clearance signage is prominently visible for local communities and workers detailing Contractor and Employer Grievance Redress Mechanism focal contacts.

Cut and fill requirements shall be minimized by design to reduce changes in topography and the extent of earthworks and thus dust generation during construction. The Contractor shall quantify the extent of earthworks required and locations for disposal of excavated spoil through landscaping within the site. Bioengineering methods to be considered for slope protection.

No piling mud must be allowed to discharge untreated to surface water, adequate bunding must be provided around piling activities to contain piling mud. Sediment laden surface water runoff must be passed through a sedimentation tank having adequate settlement tank, to obtain at least 50 mg/l TSS, before being allowed to enter surface water. Use of piling mud treatment equipment to be considered where space constraints exist preventing adequate settlement. (if necessary)

Maximum noise level should not be exceeded during any construction work. No surface water drainage will be permitted to discharge direct to surface water, sediment traps and oil interceptors shall be fitted, including on all the inflows to drainage ditches.

During construction, a solid temporary fencing shall be installed around the substation boundary to minimize the dispersion of dust, it will also function as a temporary acoustic noise fence to minimize the noise and visual impact.

Detailed design will ensure all transformers are mounted on an impermeable plinth with spill containment bund of 110% capacity.

Detailed design will provide a storage area with enclosed garbage bins where solid wastes can be segregated and stored for reuse, recycling or disposal in an undercover area with an impermeable floor.

Detailed design will provide a storage area where hazardous wastes and all liquids (fuel, oil, and chemicals, empty drums, old transformers, etc.) can be stored in a locked, undercover area with an impermeable floor with spill containment bund of 110% capacity with notice boards for material data sheets.

Emergency eye wash and shower facilities shall be located adjacent to the storage areas at the substation. Spill prevention kits (sorbent pads, absorbent material, etc.) shall also be available at storage areas and other at-risk locations within clearly labelled containers. The Control Building shall also have fully equipped first aid kits at key locations in the clearly labelled containers.

On all individual items of electrical equipment provide written and visual warning signs to include the ISO 7010 "Hazard Type: Electrical Symbol" warning of risk of electrocution with an internal fence for high-risk equipment.



Transformers purchased shall be accompanied by a letter from the manufacturer they are guaranteed PCB free and labelled as PCB free before installation. The Contractor shall provide the Employer with material data sheets for insulating oil meeting their technical specifications for use in new transformers.

Materials and equipment purchased shall be accompanied by a letter from the supplier or manufacturer saying they are guaranteed asbestos free.

Sand and stone will only be obtained from existing approved quarries with environmental clearance and all sources of water will have abstraction license. Records will be kept of the volume of all the materials used and their source.



Annexure 5

Om

Dr.

Environment Management Plan

Draft for Package 6 Bidding Documents

Document Stage: Final Draft Revised 27-05-2025

Project Number: 57258-001

May 2025

BAN: Northwest Distribution Network Modernization Project

Network Infrastructure Development and Modernization of Distribution System in NESCO Area

Prepared by Northern Electricity Supply Company (NESCO) Public Limited Company

Om

di

Table of Contents

| | |
|---|------------|
| Table of Contents | 1 |
| 1. Environment Management Plan | 1 |
| 1.1 Project Background | 1 |
| 1.2 EMP Structure | 1 |
| 1.3 Potential Impacts and Risks (General)..... | 2 |
| 1.4 Existing Facility Corrective Action Plan | 2 |
| 1.4.1 Responsibility for CAP Implementation..... | 14 |
| 1.5 Contractor’s Site Specific Environmental and Management Plans (CSEMPs) | 14 |
| 1.6 Environmental Code of Practices for Construction | 18 |
| 1.7 Mitigation Plan..... | 19 |
| 1.8 Environmental Monitoring Plan (EMoP) | 19 |
| 2. Implementation Arrangements | 20 |
| 2.1 Capacity Building and Training Requirements | 20 |
| 2.2 Implementation Schedule | 22 |
| 2.3 Cost Estimate / EMP Budget..... | 24 |
| 2.4 Supervision, Monitoring and Reporting Arrangements | 26 |
| 2.5 Implementation Arrangements..... | 29 |
| 2.5.1 Government of Bangladesh..... | 29 |
| 2.5.2 NESCO’s Management, PMU, PIU and O&M Staff..... | 29 |
| 2.5.3 NESCO’s Environment and Social Unit (ESSU) | 30 |
| 2.5.4 Project Implementation Assistance Consultant (PIAC)..... | 31 |
| 2.5.5 Contractor and Subcontractors (if any) | 32 |
| Institutional Structure and Responsibilities | 36 |
| Annex 1: Environment Management Plan | 40 |
| 1.1 Part 1 – General Mitigation | 40 |
| 1.2 Part 2 – New Substations/Substation Augmentation/Renovations/bay extensions and switching stations..... | 73 |
| Annex 2: Quantitative Monitoring to be undertaken by Contractor | 107 |
| Part 1 – General (All Works)..... | 107 |
| Part 2 – New Substations, SS Augmentation/Renovation, Bay Extensions at Existing Substations..... | 111 |
| Annex 3. Applicable Standards for EMP | 1 |
| Table 3.1: Applicable Ambient Air Quality Standards | 1 |
| Table 3.2: Applicable Noise Quality Standards | 2 |
| Table 3.3: Applicable Drinking Water Quality Standards (Groundwater Quality)..... | 3 |



| | |
|--|-----------|
| Table 3.4: Applicable Effluent Discharge Standards by Receiving Environment..... | 5 |
| Table 3.5: Applicable Inland Surface Water Quality Standards (ECR-2023)..... | 7 |
| Table 3.6: Reference Levels for Occupational Exposure to Time-Varying Electric and Magnetic Fields ... | 8 |
| Table 3.7: Reference Levels for General Public Exposure to Time-Varying Electric and Magnetic Fields | 8 |
| Table 3.8: Minimum Limits for Workplace Illumination Intensity (IFC 2027)..... | 9 |
| Table 3.9: Vibration Standard..... | 9 |
| Annex 4: Environmental Codes Of Practices..... | 10 |
| ECP 1: Waste Management..... | 11 |
| ECP 2: Fuels, Oils and Other Hazardous Substances Management..... | 13 |
| ECP 3: Water Resources Management..... | 15 |
| ECP 4: Drainage Management..... | 18 |
| ECP 5: Soil Quality Management..... | 19 |
| ECP 6: Erosion and Sediment Control..... | 21 |
| ECP 7: Top Soil Management..... | 22 |
| ECP 8: Topography and Landscaping..... | 23 |
| ECP 9: Borrow Areas Management..... | 24 |
| (note that borrow areas and dredging not permitted, only existing licensed sources are to be used)..... | 24 |
| ECP 10: Air Quality Management..... | 26 |
| ECP 11: Noise and Vibration Management..... | 28 |
| ECP 12: Protection of Flora..... | 30 |
| ECP 13: Protection of Fauna..... | 32 |
| ECP 14: Protection of Fisheries..... | 34 |
| ECP 15: Road Transport and Road Traffic Management..... | 35 |
| ECP 16: Construction Site and Labor Camp Management..... | 37 |
| ECP 17: Cultural and Religious Issues..... | 41 |
| ECP 18: Worker’s Health and Safety (including COVID-19 Prevention and Protection)..... | 43 |

1. Environment Management Plan

1.1 Project Background

1. ADB's Safeguard Policy Statement (SPS) 2009 requires that an Environmental Management Plan (EMP) be prepared to ensure construction and operation of the Northwest Distribution Network Modernization Project (the Project) will be undertaken in accordance with its safeguard requirements. This Chapter describes the EMP of the Project. It defines the roles and responsibilities for implementation, supervision and monitoring by NESCO and their Contractors; lists the mitigation measures which are to be implemented to reduce potential impacts and risks to a level acceptable to ADB and national regulatory authorities; gives guidance to the Contractors for preparation of their Contractors' Site Specific Environmental Management Plans (CSEMP) and Health Safety Plans (H&S) under the contract; gives an outline of the monitoring requirements to ensure that the mitigation measures are effective, the capacity development requirements to ensure all parties understand what is required, and, the corresponding cost of the mitigation, supervision and monitoring activities.

2. The primary aim of the EMP is to avoid, minimize, mitigate or compensate for potential negative environmental impacts and risks of the Project by identifying general and site-specific mitigation measures to be followed, and to support positive impacts where possible by enhancement measures. In doing so, it seeks to ensure compliance with (i) ADB's Safeguard Policy Statement 2009 requirements and international good practice as set out in the related International Finance Corporation (IFC) Environment, Health and Safety (EHS), General and Electric Power Transmission and Distribution guidelines, and (ii) applicable national environmental, health and safety requirements, including the international agreements which the Government of Bangladesh (GoB) is a signatory to, as well as having cognizance of the sensitivity of local ecological and human receptors in the project area of influence around each project site.

3. The specific objectives of the EMP are to:

- Summarize the potential negative environmental impacts and risks arising from the various activities associated with the construction, and operation and maintenance phases of the Project;
- Facilitate the implementation of mitigation measures to avoid, minimize, mitigate or compensate all negative impacts and risks from the design phase, through the pre-construction, construction, and the operation and maintenance phases of the Project;
- Define the roles, responsibilities, and obligations of NESCO's Project Implementation Unit (PIU) supported by a Project Implementation Assistance Consultancy (PIAC) and the environmental and social safeguards unit (ESSU) of NESCO which is to be established as part of the Project;
- Set out the roles, responsibilities, and obligations of NESCO's Contractors and other third parties; and
- Define a supervision and monitoring mechanism, plus environmental reporting requirements to check if mitigation measures are effective and ensure the environmental compliance of the Project.

The EMP reflects the legal requirements of the Bangladesh government on environment, health and safety and ADB's Safeguard Policy Statement (2009) including international good practice related to the negative environmental impacts and risks predicted during implementation. It requires adherence to guideline levels and national standards; prohibits the use of PCBs in new transformers and requires NESCO and their contractors to undertake community awareness raising activities on the health and safety risks of construction and utility electrical equipment.

4. This EMP provides the overall Project-level EMP for following contract packages involving works; it is a draft for the purposes of bidding documents and will be finalized prior to contract award:

Table 1: List of the Packages

| Package no. | Particulars | Quantity | Locations |
|---------------|---|----------|---|
| Package - GD6 | Design, Supply, Installation, Testing and Commissioning of 9 Nos. 33/11 kv AIS Substation Upgradation in Rangpur Zone | 9 | Rangpur Zone; Fakirpara, Balubari, Upasahar, Setabgonj, Panchagarh, Katkipara, Mahigonj, Dhanghora, and, Niamotpur & Golahat existing substations |

5. The generic parts of the EMP are applicable to all contract packages regardless they will follow ADB or NESCO procurement requirements. In addition, works-specific measures are provided for the different types of works related contract package as shown in Table 1. Pertinent requirements related to equipment specifications will also need to be incorporated into the contract packages for the supply of goods, different equipment and other items under the Project.

Table 2: List of 33/11 kV AIS Substation Upgradation under the Project

| SI | Sub-Project Details | Description of Civil Works | Land Ownership | Demolition Requirement | GPS Coordinate | Address/location | Remarks |
|------------|---|--|----------------|--|----------------------------------|--|---|
| GD6 | Existing Substation Upgradation | | | | | | |
| 1 | Fakirpara under S&DD-1, NESCO, Dinajpur | Yes. Land levelling and foundations etc. | NESCO | Yes. Dismantling of equipment | 25°38'36.70"N 88°38'52.59"E | Fakirpara, Dinajpur city, | |
| 2 | Balubari under S&DD-2, NESCO Dinajpur | Yes. Land levelling and foundations etc. | NESCO | Yes. Dismantling of equipment | 25°37'25.54"N 88°38'22.18"E | Balubari, Dinajpur City | |
| 3 | Upasahar under S&DD-2, NESCO, Dinajpur, | Yes. Land levelling and foundations etc. | NESCO | Yes. Dismantling of battery room and equipment | 25°36'51.62"N 88°38'49.13"E | Dinajpur | Cleaning oil spillage at foundation before installing new one |
| 4 | Setabgonj under ESU, NESCO, Setabgonj | Yes. Land levelling and foundations etc. | NESCO | Yes. Dismantling of equipment | 25°48'5.19"N 88°27'54.28"E | Setabganj, Dinajpur | |
| 5 | Panchagarh substation under S&DD-Panchagarh | Yes. Land levelling and foundations etc. | NESCO | Yes. Dismantling of battery room and equipment | 26°20'46.56" N 88°33'22.42" E | Biddyut Office (NESCO), Panchgarh | |
| 6 | Katkipara under S&DD-2, NESCO, Rangpur | Yes. Land levelling and foundations etc. | NESCO | Yes. Dismantling of equipment | 25°45'0.04"N 89°13'53.25"E | Katkipara, S&D 2 office, NESCO, Rangpur City | |
| 7 | Mahigonj under S & DD-3, NESCO, Rangpur | Yes. Land levelling and foundations etc. | NESCO | Yes. Dismantling of battery room and | 25°44'1.32"N 89°17'31.54"E | Mahiganj, Rangpur City | |

| SI | Sub-Project Details | Description of Civil Works | Land Ownership | Demolition Requirement | GPS Coordinate | Address/location | Remarks |
|----|---|--|----------------|--|--------------------------------|-------------------------------|---|
| | | | | equipment | | | |
| 8 | Dhanghora under S&DD-2, NESCO, Gaibandha | Yes. Land levelling and foundations etc. | NESCO | Yes. Dismantling of battery room and equipment | 25°19'22.25"N 89°30'30.68"E | Dhangora, Gaibandha | |
| 9 | Niamotpur & Golahat under S&DD, NESCO, Saidpur, NESCO, Nilphamari | Yes. Land levelling and foundations etc. | NESCO | Yes. Dismantling of equipment | 25°46'47.85"N 88°54'38.52"E | Niyamatpur & Golahat, Saidpur | Cleaning oil spillage at foundation before installing new one |

1.2 EMP Structure

6. The definitive version of the EMP cleared by ADB is the most recent version disclosed on its website, and it is against this that environment safeguards performance will be monitored by ADB. The EMP is a living document and may be updated as appropriate during project implementation, including in the event of any unanticipated impacts including design changes. However, any updated EMP will have to be cleared by ADB and disclosed on the ADB website.

7. Prior to the approval of detailed designs, NESCO will identify and review the implications of any design changes to the Project as assessed in the IEE and consult Department of Environment and ADB regarding the need to update the IEE and thus EMP considering any variations put forward by their Contractors. If required, the IEE will be updated by NESCO for Department of Environment approval and/or for review, clearance, and disclosure by ADB before NESCO supported by the Project Implementation Assistance Consultancy (PIAC) approve the Contractors designs and the start of any related works by their Contractors including site establishment and vegetation clearance. NESCO supported by PIAC will prepare the updated IEE/EMP, but the contractor will be required to support them with the preparation.

8. NESCO will award various contract packages including contract package 6 (which involve civil works related to substation upgradation) following ADB procurement requirements. The Contractors for all civil works packages will be contractually bound to implement the EMP. NESCO will ensure the EMP forms part of all bidding and contract documents for all works contract packages. During design and pre-construction, and construction, the Contractors will be responsible for implementing all relevant measures for the works in their contract package under the supervision of NESCO supported by their PIAC up until handover of the infrastructure to NESCO. Any updates to it will be incorporated through a contract variation into the contract document. The Contractors must always follow the current version of the EMP which is the version disclosed on ADB's website. This includes any updates in response to unanticipated impacts.

9. To ensure the mitigation and monitoring measures are implemented, the environmental monitoring plan (EMoP) will be followed by NESCO supported by their PIAC. Some quantitative monitoring in the EMoP will be delegated to the Contractors to undertake. For pre-construction monitoring this must be completed before the start of any related works by Contractors including site establishment and vegetation clearance. In addition, in case of any requirement for corrective action due to noncompliance to the EMP during project implementation, these must be identified and immediately reported to ADB. Appropriate corrective action(s) will be agreed between ADB and NESCO to bring the project implementation back on track. Corrective actions must be time-bound, budgeted and agreed between ADB and NESCO. The Contractors will cover the costs where corrective action is required due to noncompliance on behalf of the Contractor, its subcontractors or third parties it engages with the EMP.

10. This EMP covers the following:

- the proposed Corrective Action Plan for existing facilities (9 no. of existing substations under package 6), to be implemented by NESCO;
- the Mitigation Plan, covering the mitigation of impacts and risks (during detailed design and pre-construction; construction, and operation and maintenance), including activity-specific and site-specific mitigation for the existing substation upgrades (details in Annexure-1 (Part-2)) . Part of this plan is the requirement for Contractors to develop Contractor' Site Specific Environmental Management Plans (CSEMPs) and H&S Plans, both with several sub-plans, incorporating the measures described in the mitigation plan and additionally the general construction management measures described in the Environmental Codes of Practice (ECPs);
- a quantitative EMoP including monitoring parameters and performance indicators, including general monitoring and activity-specific and site-specific monitoring for the



- existing substation upgrades (details in Annexure-2 (Part-2))
- implementation arrangements, including (a) the organizational roles and responsibilities for mitigation, supervision, monitoring and reporting; (b) capacity building needs; and (c) an initial cost estimate/EMP budget subject to competitive bidding by contractors and PIAC.

11. In addition, NESCO and their Contractors have a role in implementing the grievance redress mechanism (GRM) for the facilitation of complaints or queries on project-related activities.

1.3 Potential Impacts and Risks (General)

12. The principal purpose of formulating the EMP is to ensure commitments made are translated into implementation. Potentially significant impacts relate to construction due to upgradation of existing substations however, no significant impacts are anticipated during operation period.

13. Impacts and risks are summarized as follows:

- Dust generation affecting the public and occupants of properties in immediately adjacent buildings due to land filling, levelling works, earthworks for construction, and transportation of materials.
- Noise and vibration causing disruption and disturbance to the public and occupants of properties in immediately adjacent buildings especially from piling work, etc.
- Use of hazardous materials, including transformer oils, and batteries, and the generation of solid and hazardous wastes including e-wastes during both construction and operation.
- Loss of mature trees and scrub vegetation at substation sites including potential disturbance to nesting birds during site clearance and requiring 1:3 compensatory plantation following preparation of a Tree Plantation Plan.
- No protected area, forest land, natural habitat, or critical habitat and Physical Cultural Resources such as archaeological or heritage sites is impacted.
- Occupational health and safety risks to workers including from working at height in construction and with electrical equipment.
- Community health and safety due to the presence of workers, construction traffic, structural safety of immediately adjacent buildings due to vibrations/noise from construction works etc.
- Construction impacts will adversely affect baseline parameters (e.g., air, noise, water quality) and impacts must be minimized through targeted mitigation measures and regular monitoring.
- Concerns of the community and other key stakeholders regarding contractor violations that may adversely impact them (e.g., dust, noise, health and safety) need to be addressed through detailed design and construction methods with supervision and monitoring to ensure compliance.

1.4 Existing Facility Corrective Action Plan



14. Site inspections of 9 existing substations related to the 33/11 kV existing substation upgrade components were undertaken during April-May 2024 and November 2024. This environmental audit of the existing substations culminated in a Corrective Action Plan (CAP) to amend any noncompliance. This CAP is contained in Table-3 for 9 existing substations. Corporate actions will be undertaken by NESCO prior to access being given to the contractors. NESCO will implement the other items in the CAP either themselves with support from PIAC through their substation managers or through the contractors. NESCO will be responsible for submitting a report confirming the completion of corrective actions to ADB for clearance prior to the Contractor being given access to the existing substation in question to undertake works including site establishment.

15. NESCO substation in-charge will be responsible for applying any corrective actions under the guidance of the PIU and the PIAC unless PIU delegates them to the respective contractor through the scope of the contract before access is granted for works located within existing substations. NESCO will be responsible for reflecting such corrective actions in the bidding and contract documents, the contractors will then be responsible for implementing those items that are delegated to them by NESCO as part of their contractual obligations, in addition to the requirements of the EMP mitigation plan which are to be followed whilst undertaking works in existing substations.





Table 3: Corrective Action Plan of 9 Existing Substations for Upgradation under Package 6

| Non-Compliance Issue | Corrective Action Plan of Existing Substations for Upgradation) | By whom | By when | Budget (source) | Remarks |
|----------------------|---|---------------------------------------|--|-----------------|--|
| | SHORT TERM CORRECTIVE ACTIONS | | | | |
| General | <ul style="list-style-type: none"> Ensure existing EHS guidance, pollution prevention and hazardous waste management manuals are kept on site Provide all SS managers with EHS awareness training so they can understand and implement the corrective action that is required at each SS Provide specific training to all SS managers/workers on PCBs to raise awareness of the risks and the need for compliance with national regulations; the National Implementation Plan (NIP) for the Management of Persistent Organic Pollutants (POPs), as well as the Bangladesh Standards and Guidelines for Sludge Management etc. for the handling and disposal of PCBs. | PIU with support of PIAC and ESS unit | Upon loan effectiveness with compliance to be confirmed by ESS Unit and PIAC prior to access by EPC Contractor or the start of works | NESCO | Applicable for all existing S/S sites |
| | <ul style="list-style-type: none"> Submit a status report for each SS confirming the implementation status of short-term corrective action plan to ADB for clearance prior to commencement of any works at the SS in question. | PIU with support of PIAC and ESS unit | Before access to SS given to contractor with compliance to be confirmed by ESS Unit and PIAC prior to access by EPC Contractor or the start of works | NESCO | Applicable for all existing S/S sites. |
| | <ul style="list-style-type: none"> Records of all EHS permits applicable to the SS to be made available at the SS site | PIU with support of PIAC and ESS unit | Before access to SS given to contractor with compliance to be confirmed by ESS Unit and PIAC prior to access by EPC Contractor or the start | NESCO | Applicable for all existing S/S sites. |

| Non-Compliance Issue | Corrective Action Plan of Existing Substations for Upgradation) | By whom | By when | Budget (source) | Remarks |
|--------------------------------|---|--|---|---|--|
| Housekeeping/ waste management | <ul style="list-style-type: none"> • Develop standardized waste management system/procedure in accordance with national laws and regulations and the EHS Guidelines on Waste Management for all substations. System/procedure to include avoiding or minimizing the generation of waste materials, as far as practicable. Where waste generation cannot be avoided but has been minimized, the preference should be recovery and reuse. Where waste cannot be recovered or reused, reputable, legitimate, licensed contractors must be appointed to treat, destroy, and dispose of it in an environmentally sound manner. • Develop as part of system/procedure a checklist for SS managers on correct storage and disposal of transformer oils, other fuel, oil, and chemicals, old transformers, scrap metals, electronic wastes, municipal solid wastes, and wastewater etc • Provide training to all SS managers on implementation of the waste management system/procedure and use of the checklist (document training and attendance by SS managers). • SS managers to provide training to all SS staff (including housekeeping staff) on waste management system/procedure. • Implement waste management system/procedure to include the segregation of all solid and hazardous waste generated; and environmentally sound storage of all solid and hazardous waste. • Identify dedicated labelled storage areas for hazardous materials and segregated waste; ideally storage will be in a locked area, under cover to provide shelter from the elements, having fully enclosed garbage bins for the disposal of municipal solid waste, and where liquids or leachable materials are stored having an impermeable floor bunded to 110% capacity of the volume that is stored. Ensure labelled, covered, enclosed garbage bins and drip trays available. • If impermeable floor bunded to 110% is not available in the short-term, liquid and leachable materials/waste to be kept on drip trays to provide secondary containment. • Tidy up the SS ensuring all materials and wastes including cables, broken | PIU (contractor) with support of PIAC and ESS unit | of works Before access to SS given to contractor, or if including corrective action in contract this is to be completed by contractor before they commence works, with compliance to be confirmed by ESS Unit and PIAC prior to access by EPC Contractor or the start of works | NESCO (contractor BOQ per scope of works) | The sites are neat and clean, wastes mainly collected by waste-bins and disposed of in the land fill site but e-waste management is not found at any site. |

Om

Dr

| Non-Compliance Issue | Corrective Action Plan of Existing Substations for Upgradation) | By whom | By when | Budget (source) | Remarks |
|------------------------------|--|--|---|---|---|
| | <p>electrical systems, meters, glass and plastic, oils etc. are collected up, segregated, and stored in the designated and labelled storage areas</p> <ul style="list-style-type: none"> Remove (and prohibit any further) end-of-life equipment or waste stored outside the SS boundary relocating it to designated and labelled storage areas within the SS. Remove all end-of-life equipment that has built up on site to NESCO stores with storage, transport, and disposal as per the GoB regulations following the waste hierarchy Remove all other waste that has built up on site by appropriately licensed waste management company with all storage, transport, and disposal as per GoB regulations Hazardous Waste and Ship Breaking Waste Management Rules, 2011 (ii) Solid Waste Management Rules 2021 (iii) E-Waste Management Rules, 2021, and (iv) National 3 R Strategy for Waste Management, 2010, | | | | |
| Transformers and oil leakage | <ul style="list-style-type: none"> Develop and cascade to all SS for implementation a strengthened, standardized waste oil and oil spill plan/procedure in accordance with national laws and regulations and the EHS Guidelines on Hazardous Materials Management. Provide training to all SS managers on implementation of the waste oil and spill plan/procedure and use of the checklist (document training and attendance by SS managers) Ensure drip trays and absorbent material (e.g. dry sand, sandbags) are available at SS to soak up spills. Filled drums (mineral oil) are all to be sealed and labelled with their contents with safety warnings MSDS to be available at the SS site for all the materials used on site Collect up and store empty and filled drums (mineral oil) in a locked, under cover, designated storage area, they should either be stored on an impermeable floor bunded to 110% capacity of volume stored, or if not available in the short-term kept on drip trays to provide secondary containment | PIU (contractor) with support of PIAC and ESS unit | Before access to SS given to contractor, or if including corrective action in contract this is to be completed by EPC contractor before they commence works, with compliance to be confirmed by ESS Unit and PIAC prior to access by EPC Contractor or the start of works | NESCO (contractor BOQ per scope of works) | Only logbook is maintained at the sites (register of transformer incoming and outgoing list) other items are not well maintained at the existing substations sites. |

| Non-Compliance Issue | Corrective Action Plan of Existing Substations for Upgradation) | By whom | By when | Budget (source) | Remarks |
|----------------------|---|---------|---------|-----------------|---------|
| | <ul style="list-style-type: none"> • Defunct transformers prior to being removed from site are to be placed in a designated storage area, they should either be stored on an impermeable floor bunded to 110% capacity of volume stored, or if not available in the short- term kept on drip trays to provide secondary containment • Inventory to be prepared of existing transformers on site, make, model, risk of PCBs and other details including transformer test report, details any maintenance works undertaken, dates oil changes, leakage incidents etc. • Clearly label all transformers as either containing PCBs, at risk of containing PCBs, or PCB-free provided documentary evidence exists. • Carry out inspections and preventive maintenance to minimize oil leakages; ensure valves, nuts and bolts are fully functional and tightly secured, ensure rubber seals of radiators are intact • Existing transformers in a poor state of repair and which are currently leaking oil to be maintained/repared so they are left in good condition • Health and safety risk assessment for exposure of staff to PCBs to be undertaken before maintenance/repair work is undertaken on any existing SS transformers • Clean up all existing oil spill, excavate any contaminated soil and send for disposal (as hazardous waste) using appropriately licensed waste management company with all storage, transport, and disposal as per the Hazardous Waste and Ship Breaking Waste Management Rules, 2011 or if found containing PCBs following the guidance of Department of Environment • Make available spill management materials (sorbent pads, loose sorbent material, sand, etc.) next to the storage area for immediately soaking up any leaks or spills that do accidentally occur. • Stored transformers must first be moved to an undercover, impermeable | | | | |

Om

Dr

| Non-Compliance Issue | Corrective Action Plan of Existing Substations for Upgradation) | By whom | By when | Budget (source) | Remarks |
|--|--|--|---|---|--|
| | <p>110% banded storage area, (with separate storage areas for potential PCB containing transformers, non-reparable transformers as well under repair transformers)</p> <ul style="list-style-type: none"> Comprehensive soil sampling undertaken to inform a strategy for remediation, anticipated to involve either the removal of soil off-site as approved by DOE to take hazardous material or encapsulation. The guidelines of UNIDO must be followed in handling all transformers since due to recycling of oil none can be guaranteed PCB free; and the contractor should test all transformers disturbed by the project. | | | | |
| Noise, lighting, ventilation, EMF, and | <ul style="list-style-type: none"> Defunct bulbs/lights to be replaced Provide adequate natural and/or artificial lighting levels to meet the WBG EHS Guidelines on Occupational H&S (<i>Table 2.3.3. Minimum Limits for Workplace Illumination Intensity</i>) within control rooms, toilets, stairways, and other areas having regular staff movements | PIU (contractor) with support of PIAC and ESS unit | Before access to SS given to contractor, or if including corrective action in contract this is to be completed by contractor before they commence works, with compliance to be confirmed by ESS Unit and PIAC prior to access by EPC Contractor or the start of works | NESCO (contractor BOQ per scope of works) | Applicable for all existing substations sites. |
| First aid and PPE | <ul style="list-style-type: none"> Develop as part of health and safety system/procedure a checklist for Substation managers on correct content of first aid kit, PPE to be provided, need for renewal if out of date etc. Source and make available fully stocked, in-date, first aid kit in each main working area in a prominent, signed position and easily accessible; to include a list of equipment and use by dates as well as poster of the first aid procedures and emergency contact details of NESCO and local hospital Periodic checks of first aid kits at substations should be carried out to check the contents and expiry dates | PIU (contractor) with support of PIAC and ESS unit | Before access to SS given to contractor, or if including corrective action in contract this is to be completed by contractor before they commence works, with compliance to be confirmed by ESS Unit | NESCO (contractor BOQ per scope of works) | Applicable for all existing substations sites. |

| Non-Compliance Issue | Corrective Action Plan of Existing Substations for Upgradation) | By whom | By when | Budget (source) | Remarks |
|-----------------------|---|--|---|---|--|
| | <ul style="list-style-type: none"> • Provide eye wash station and water supply to a shower located near the storage areas for fuel/oil/chemicals. • Source and make available fully stocked, in-date, PPE in each substation; to include a list of equipment (footwear, masks, protective clothing, and goggles in appropriate areas) and use by dates as well as poster of the appropriate PPE to be worn in accordance with GOB requirements and the EMP • Periodic checks of PPE at substations should be carried out to check the contents and expiry dates • Develop as part of health and safety system/procedure an incentive/disciplinary system to ensure use of PPE by workers at SS, such as use of written warnings etc. • Ensure appropriate PPE is actively used by staff by implementing the incentive/disciplinary system. • Provide training to all SS managers on use of the checklist and incentive/disciplinary system, as well as on (i) use of PPEs - the importance of safety needs to be stressed to effect behavioral/attitudinal change, and (ii) general health and safety aspects | | and PIAC prior to access by EPC Contractor or the start of works | | |
| Fire safety equipment | <ul style="list-style-type: none"> • Electrical safety mats must be installed at all substations • Provide sand buckets, full of sand, placed in a prominent, signed location near to fire-risk locations such as transformers and oil storage areas. • Make available fire extinguishers (including for oil and electric fires) in a prominent, signed location near to fire-risk locations such as transformers and oil storage areas with service and expiration dates clearly labelled. • Expired/exhausted fire extinguishers to be refilled/replaced so all are in date. | PIU (contractor) with support of PIAC and ESS unit | Before access to SS given to contractor, or if including corrective action in contract this is to be completed by contractor before they commence works, with compliance to be confirmed by ESS Unit and PIAC prior to access by EPC Contractor or the start of works | NESCO (contractor BOQ per scope of works) | Applicable for all existing substations sites. |
| Community H&S | <ul style="list-style-type: none"> • Doors to control rooms to be kept shut during both day and night. • Security persons are to be deployed at all SS for 24x7 period with | PIU (contractor) with support | Before access to SS | NESCO | Applicable for |

| Non-Compliance Issue | Corrective Action Plan of Existing Substations for Upgradation) | By whom | By when | Budget (source) | Remarks |
|----------------------|--|--|---|-------------------------------------|--|
| | <p>rotation/shifts. Number of security guards is to be determined by NESCO based on the size/area of the SS and adjacent land use.</p> <ul style="list-style-type: none"> • Dedicated shelter to be provided at the site entrance for use by any security guards, shielding them from rain, wind, and extreme (hot and cold) temperatures. • Switch yard area/transformers are also to be fenced having a locked gate with visual and written warning signages including the ISO 7010 Hazard Type: Electrical Symbol warning of the risk of electrocution. • Safety signage with large and colorful display to be placed along SS boundary and at gate with visual and written warning signages including the ISO 7010 Hazard Type: Electrical Symbol warning of the risk of electrocution. • Safety sign to be placed to make local community aware that the SS site is out of bounds. | of PIAC and ESS unit | given to contractor, or if including corrective action in contract this is to be completed by contractor before they commence works, with compliance to be confirmed by ESS Unit and PIAC prior to access by EPC Contractor or the start of works | (contractor BOQ per scope of works) | all existing substations sites. |
| Handling emergencies | <ul style="list-style-type: none"> • Develop and cascade to all SS for implementation a standardized hazardous materials management system/procedure in accordance with national laws and regulations and the EHS Guidelines on Hazardous Materials Management • Develop as part of system/procedure a checklist for SS managers on correct storage and disposal of transformer oils, other fuel, oil, and chemicals, old transformers, scrap metals, electronic wastes, municipal solid wastes, and wastewater etc. • Provide training to all SS managers on implementation of the hazardous materials management system/procedure and use of the checklist (document training and attendance by SS managers) • Identify and install emergency exit signage on all emergency exits • Keep clear all the emergency exits, remove blockages due to storage of end-of-life equipment • Provide first aid posters including first aid for electrocution incident • Prominently post a list of doctors/emergency health/fire station contacts (names/locations/phone numbers) list in case of emergency • Provide posters on fire safety • Establish and maintain an incident logbook | PIU (contractor) with support of PIAC and ESS unit | Before access to SS given to contractor, or if including corrective action in contract this is to be completed by contractor before they commence works, with compliance to be confirmed by ESS Unit and PIAC prior to access by EPC Contractor or the start of works | NESCO | Applicable for all existing substations sites. |

Om

Dr.

| Non-Compliance Issue | Corrective Action Plan of Existing Substations for Upgradation) | By whom | By when | Budget (source) | Remarks |
|----------------------|--|--|---|---|---|
| | <ul style="list-style-type: none"> • Provide training to all SS managers on emergency procedures in event of accident, fire or natural hazard to be given on a train-the-trainer basis (document training and attendance by SS managers) • Provide training to all SS managers on the development and implementation of emergency preparedness and response plans for (i) environmental incident, (ii) health and safety incident in accordance with the General EHS Guidelines | | | | |
| H&S of Staff | <ul style="list-style-type: none"> • Ensure H&S risk assessment is completed for the SS operation and maintenance works undertaken and that appropriate H&S management actions identified (copy of risk assessment and the action plan to be kept on site) • Building structural status – ensure building repairs are undertaken to maintain the integrity of control buildings especially in the event of an earthquake • Broken slabs at SS need immediate replacement to avoid any slip, trip or fall related accidents • Safety sign boards must be installed within the substation and at substation boundaries including visual warning of electrocution • Mark emergency exist signage and ensure emergency exit routes are kept clear of debris at all times • Conduct fire drills and alarm tests on a monthly basis with records kept • Place posters on medical revival, prevention / fire safety • Ensure SS has adequate drainage to avoid damp and wet conditions • Provide storm drainage at the SS with oil-water separator on all drains | PIU (contractor) with support of PIAC and ESS unit | Before access to SS given to contractor, or if including corrective action in contract this is to be completed by contractor before they commence works, with compliance to be confirmed by ESS Unit and PIAC prior to access by EPC Contractor or the start of works | NESCO (contractor BOQ per scope of works) | Applicable for all existing substations of sites. |
| Old Equipment | <ul style="list-style-type: none"> • Bunded storage area for old equipment / replaced equipment will be established. Must be able to contain at least 110% of total capacity. | PIU (contractor) with support of PIAC and ESS unit | Before access to SS given to contractor, or if including corrective action in contract this is to be completed by contractor before they commence works, | NESCO (contractor BOQ per scope of works) | Applicable for all existing substations of sites. |

| Non-Compliance Issue | Corrective Action Plan of Existing Substations for Upgradation) | By whom | By when | Budget (source) | Remarks |
|-----------------------------------|---|--|---|--|--|
| | | | with compliance to be confirmed by ESS Unit and PIAC prior to access by EPC Contractor or the start of works | | |
| Sanitation and welfare facilities | <ul style="list-style-type: none"> • Provide potable drinking water supply meeting GoB drinking water standards (regular testing of drinking water is included in IEE EMOP scope) • For all existing toilets ensure adequate lightening, repairing of door, locks, and latches provided as well as hand washing facilities with soap and water • Cleaning of existing toilets on daily basis, use of disinfectant and floor cleaners • Ensure all sources of wastewater including bathing, basins and urinals (not just toilet pans) connected to septic tank • Ensure that septic tanks are well maintained • Install a soakaway for disposal of the septic tank wastewater, no untreated wastewater should be disposed of to surface water or ground • For the welfare of SS staff during their shifts provide a dedicated cooking area / clean eating area / rest area for staff on-site that meets GoB and ILO worker accommodation requirements; if cooking is permitted a separate cooking area that does not pose a fire hazard | PIU (contractor) with support of PIAC and ESS unit | Before access to SS given to contractor, or if including corrective action in contract this is to be completed by contractor before they commence works, with compliance to be confirmed by ESS Unit and PIAC prior to access by EPC Contractor or the start of works | NESCO (contractor BOQ per scope of works) | Current status is good |
| | LONG TERM CORRECTIVE ACTIONS | | | | |
| General | <ul style="list-style-type: none"> • Updating the existing NESCO corporate policy of Environment, Health and Safety following IFC Guideline of Electrical Power Transmission and Distribution, 2007. • SOP developed to include guidelines for pollution prevention including management or handling procedures for oil spills, spillage, runoff from leaks off equipment, and waste management, including for hazardous waste management • SOP developed to include guidelines for H&S management including | PIU (contractor) with support of PIAC and ESS unit | Prior to commissioning by the EPC contractor, with compliance to be confirmed by ESS Unit and PIAC prior to the start of commissioning works | NESCO with guidance of PIAC in preparing the SOP | Applicable for all existing substations sites. |

| Non-Compliance Issue | Corrective Action Plan of Existing Substations for Upgradation) | By whom | By when | Budget (source) | Remarks |
|--------------------------------|---|--|--|---|---|
| | <p>emergency preparedness</p> <ul style="list-style-type: none"> • Ensure copy of EHS policy and SOP available at all SS • Provide SS managers/workers on training with respect implementation of the SOP • Submit a status report for each SS confirming the implementation status of long-term corrective action plan to ADB for clearance prior to commissioning of the SS in question by the contractor | | | | |
| Housekeeping/ waste management | <ul style="list-style-type: none"> • In SS where a locked, under cover material and waste storage area with an impermeable floor bunded to 110% capacity of the volume stored are not available construct a storage of fuel/oil/chemicals and solid/hazardous waste | PIU (contractor) with support of PIAC and ESS unit | Prior to commissioning by the contractor, with compliance to be confirmed by ESS Unit and PIAC prior to the start of commissioning works | NESCO (contractor BOQ per scope of works) | Applicable for all existing substations of sites. |
| Transformers and oil leakage | <ul style="list-style-type: none"> • In SS where existing transformers are at risk of containing PCBs (with reference to Department of Environment (UNIDO) guidelines e.g., those transformers manufactured before 1980 are of most concern but others that are manufactured before 2016 are also being tested by DOE initiative as they may still be contaminated) ensure they are tested (such testing is included in IEE EMoP scope) • For those transformers confirmed as containing PCBs ensure these are dechlorinated or removed from site with storage, transport, and disposal as per the Hazardous Waste and Ship Breaking Waste Management Rules, 2011 and in consultation with DoE as per their guidelines – transformers with PCBs to be detected and cleaned by 31.12.2025 under the Stockholm Convention. NESCO to submit to ADB proof all substation transformers are PCB free before loan completed. • In SS, where bund of 110% capacity extending beyond the transformer footprint is not available, retrofit such a bund to existing transformers • For substations, waste disposal is a concern, except for waste oil which is taken by a contractor all solid and hazardous waste is disposed of to the municipalities who do not have a sanitary landfill meaning it is open | PIU (contractor) with support of PIAC and ESS unit | Prior to commissioning by the contractor, with compliance to be confirmed by ESS Unit and PIAC prior to the start of commissioning works | NESCO (contractor BOQ per scope of works) | Applicable for all existing substations of sites. |

| Non-Compliance Issue | Corrective Action Plan of Existing Substations for Upgradation) | By whom | By when | Budget (source) | Remarks |
|--|---|--|--|--|--|
| | <p>dumped. Oily sludge generated may be collected that cannot be recycled must be disposed of to hazardous waste management vendor to avoid it being open dumped.</p> <ul style="list-style-type: none"> NESCO to establish hazardous waste storage areas at the substation and an MOU with O&M hazardous waste management organization, Stored transformers must be moved from the substations to the transformer workshops they are not to be stored at the substation, any short term temporary storage to be in an undercover, impermeable 110% bunded storage area. The guidelines of UNIDO must be followed in handling all transformers since due to recycling of oil none can be guaranteed PCB free; and the contractor should test all transformers removed by the project. | | | | |
| Noise, lighting, ventilation, EMF, and | <ul style="list-style-type: none"> Conduct EMF measurements for each substation using ICNIRP standards and keep the test results at site office Control panel and other equipment within SS control buildings to be rearranged and placed in a manner to maximizing natural ventilation and light Switch yard lighting system to be improved so all areas well-lit at night when required | PIU (contractor) with support of PIAC and ESS unit | Prior to commissioning by the contractor | NESCO (contractor BOQ per scope works) | Applicable for all existing substations sites. |
| Fire safety equipment | <ul style="list-style-type: none"> Ensure automatic fire alarm, fire suppression systems and firewalls installed | PIU (contractor) with support of PIAC and ESS unit | Prior to commissioning by the EPC contractor, with compliance to be confirmed by ESS Unit and PIAC prior to the start of commissioning works | NESCO (contractor BOQ per scope works) | Applicable for all existing substations sites. |
| Handling emergencies | <ul style="list-style-type: none"> Ensure a SS specific emergency preparedness plan is developed including the communication system and protocols for response to a fire, earthquake, flood, medical emergency etc. and followed for SS operation with regular fire drills and alarm tests conducted (copy kept | PIU (contractor) with support of PIAC and ESS unit | Prior to commissioning by the contractor, with compliance to be | NESCO (contractor BOQ per scope of | Emergency response plan should be prepared |

| Non-Compliance Issue | Corrective Action Plan of Existing Substations for Upgradation) | By whom | By when | Budget (source) | Remarks |
|----------------------|--|--|--|---|---|
| | <ul style="list-style-type: none"> on site) • Ensure all SS workers receive basic first aid and firefighting training with annual refreshers • Ensure that at least one staff at SS is fully trained as a first aider and fire marshal and is on site at all times • Ensure lightening protection equipment is installed at the substations • Monitor and maintain account of the oil usage and spills/leaks at SS and have a site based plan/procedures for dealing with oil spills • Provide in a signed accessible location on-site sufficient absorbent materials (e.g. dry sand, sandbags) for soaking up oil spills. • Soak up existing oil spills and, as required, remove soil to approximately a depth of 30cm for 1m beyond footprint of visible spillage for disposal to hazardous landfill site by reputable, legitimate, licensed contractor keeping photographic records and waste transfer notes. Extra gravel is to be placed to intercept and prevent any further oil percolation into the ground. • SS manager to provide training to all SS staff (including housekeeping staff) on waste oil and spill plan/procedure. • Soil and groundwater investigation to be undertaken by suitably qualified consultant to confirm extent of any contamination across/beneath SS from oil leaks and spills and additional remedial measures required. • Implement any additional remedial measures identified following the testing of soil and groundwater. | | confirmed by ESS Unit and PIAC prior to the start of commissioning works | works) | and maintained for all the existing substations sites. |
| Drainage | <ul style="list-style-type: none"> • Ensure SS has adequate drainage to avoid damp and wet conditions • Provide storm drainage at the SS with oil-water separator on all drains | PIU (contractor) with support of PIAC and ESS unit | Prior to commissioning by the contractor, with compliance to be confirmed by ESS Unit and PIAC prior to the start of commissioning works | NESCO (contractor BOQ per scope of works) | Existing drainage system should be updated for all existing substation sites. |

1.4.1 Responsibility for CAP Implementation

16. NESCO management and substation in-charge will be responsible for applying any corrective actions under the guidance of the PIU and the PIAC unless PIU delegates them to the respective Contractor through the scope of the contract before access is granted for works located within existing substations. NESCO with support PIAC will be responsible for submitting a report confirming the completion of corrective actions to ADB for clearance prior to the Contractor being given access to the existing substation in question to undertake works including site establishment.

17. The Contractor for those contract packages involving existing substations will be responsible for implementing corrective actions that are delegated to them by NESCO as part of their contractual obligations, in addition to the requirements of the EMP mitigation and monitoring plans which are to be followed whilst undertaking all works in existing substations.

1.5 Contractor's Site Specific Environmental and Management Plans (CSEMPs)

18. The Contractor will be responsible for the development of Contractor's Site-specific Environmental Management Plans (CSEMPs) and H&S Plans, setting out in detail how it will implement the measures listed in the Mitigation Plan and other commitments NESCO has made in this Project EMP. The general measures which will be included within them are described in the ECPs. Contractors will need to obtain PIU approval of their CSEMPs and H&S Plans prior to the commencement of works which includes site establishment and vegetation clearance. PIAC will support the PIU in reviewing and approving the CSEMPs and H&S Plans, including all sub-plans, such as Tree Plantation Plans and Emergency Preparedness and Response Plans. NESCO will need to ensure the CSEMP, H&S Plan and other subplans mirror and do not conflict with the Project EMP requirements and any requirement of national laws and regulations, including environmental clearance requirements. The CSEMP and H&S Plan will be a living document to be updated as required and reapproved by NESCO if construction methods or site conditions change or in response to an incident, near miss etc.

19. The key subplans of the CSEMP which will be prepared and implemented by Contractor will include the following – the H&S Plan is to be a standalone plan given its importance but is considered here as a subplan:

Demolition and Construction Method Statements describing how each activity involved in demolition (as applicable) and construction works will be undertaken (schedule, access routes, anticipated traffic volumes, and working methods) with respect to ensuring compliance with the Project EMP requirements. Note: a separate Asbestos Management Plan will need to be prepared if asbestos is to be expected in the buildings that are to be demolished.

Temporary Facilities Plan, including details and the layout of the various temporary construction facilities required including any access roads, offices and workshops, material storage, laydown areas, refuelling areas, waste storage areas, rest areas, sanitation and welfare facilities, construction labor camps or overnight accommodation.

Pollution Prevention Plan, to be prepared with reference to the IFC EHS Guideline environmental requirements including those on Construction and Demolition.¹ This plan will detail the measures to control noise and vibration and, if required, include separate demolition, piling and blasting management plans. Measures to control dust and air emissions will be

¹ https://www.ifc.org/wps/wcm/connect/topics_ext_content/ifc_external_corporate_site/sustainability-at-ifc/policies-standards/ehs-guidelines

included and details of how water resources will be protected, how water discharges including spills and leaks, surface water runoff, bentonite slurry and concrete wash water will be managed. The procedures and designated areas for the environmentally safe and sound storage, transportation and use of fuel, oil, and other hazardous substances, as applicable, will be described. Further, this plan will cover the issue of SF6 management.

Spoil Management Plan on the management of excess spoils from various excavation, site levelling and cut and fill activities.

Piling Management Plan specifically addressing noise and the management of drilling and piling mud, for all activities where piling is required. The piling management plan will include measures to avoid water pollution from the use of any bentonite clay slurry - adequate bunding must be provided around piling activities to contain drilling and piling mud and decanting ponds will need to be fully enclosed to avoid spills or leaks to adjacent land. Drilling and piling fluid must not be intentionally or unintentionally disposed of to surface water untreated or be allowed to damage adjacent land. Sediment laden surface water runoff and discharges must be disposed of to open ground for percolation or passed through a sedimentation tank having adequate settlement tank, to obtain at least 50 mg/l TSS, before being allowed to enter surface water. Use of drilling and piling mud treatment equipment to be considered where space constraints exist preventing adequate settlement.

Waste Management Plan, detailing the measures required for the environmentally safe and sound collection, segregation, storage, transportation, and disposal of all solid and hazardous waste referring to the IFC EHS Guidelines on Waste Management and Construction and Demolition. The management of sanitary wastewater will be described. The plan will itemize how wastes can be reduced and recycled - disposal will be the last resort. For example, food waste can be composted, plastic waste – can be reused and recycled, other domestic waste e.g., cans, paper etc. is able to be recycled, demolition waste e.g., bricks, concrete etc. can be reused during construction or by others for their construction, metals – can be recycled, wood – can be recycled, and, hazardous used oil can be reused providing that it is PCB free and taken by the suitably licensed vendors of DOE. The waste management plan will identify the suitably licensed reuse/recycling vendors and waste management facilities for the disposal of solid and hazardous wastes to be used by the Contactor. Note: a separate Asbestos Management Plan will need to be prepared if asbestos is to be expected in the buildings that are to be demolished for disposal of asbestos waste as it is hazardous.

Drinking Water Supply and Sanitation and Welfare Plan. This plan will detail measures to ensure adequate water supply and sanitation and welfare provisions for the temporary construction facilities, including offices, rest areas, washrooms, and construction labor camps or overnight accommodation in order not to cause shortages and/ or contamination of existing drinking water sources and to ensure the safe and healthy working conditions for the labourers.

Occupational and Community Health and Safety (H&S) Plan. This plan will be informed by a facilitated health and safety risk assessment participated in by NESCO/PIAC and the Contractors and detail out workplace and community health and safety measures following the mitigation hierarchy referring to the IFC EHS Guidelines related to H&S and the ILO guidelines.² Risks of communicable vector borne and viral diseases to also be addressed including adequate sanitation and welfare facilities to prevent the spread of disease.³

² <https://www.ilo.org/resource/other/safety-and-health-construction-revised-edition>

https://www.ilo.org/sector/Resources/codes-of-practice-and-guidelines/WCMS_861584/lang--en/index.htm

³ Contractors will provide adequate sanitation and welfare facilities including hand washing and PPE in sufficient quantity on-site and at construction labor camps/overnight accommodation so workers can follow healthy hygiene practices as well as

Subplans will include:

- **Safety Training Program** – to provide general and specialized training courses for all workers on the site and at all levels of supervision and management. General courses will consist of (i) an initial Safety Induction which all workers will be required to attend prior to being allowed to work on site, all visitors and project workers who have not attended the safety induction course must be always accompanied by inducted workers when within the working area and (ii) periodic safety training refreshers covering similar topics to induction, conducted not less than once every six months. All subcontractor workers will be required to participate in relevant training courses appropriate to the nature, scale, and duration of the subcontract. Since they have heightened risk only trained workers must undertake certain activities e.g., working at height, working in confined spaces, working with electricity etc. Workers must have attended such training before they are involved in relevant works and the contractor must either offer an internal training course or organize for attendance at an external specialist training course. Workers must have a training record of attending a suitable training course. Untrained workers will not be permitted to work at height, enter confined spaces, work with live electricity etc.
- **Medical Check-Up/Health Surveillance** – of workers fitness, eyesight, hearing, respiratory health, and communicable and noncommunicable diseases before works commence; and then repeated every six months by the contractor during construction. Only workers who have passed their fitness test and have the requisite medical clearance must undertake certain activities e.g., working with electricity etc.
- **Safety Meetings** – to be conducted monthly during construction phase by NESCO. During construction the meetings will require attendance by the safety representatives of all contractors and subcontractors on-site. The minutes of all safety meetings including actions agreed will be taken and sent to NESCO within seven days of the meeting.
- **Safety Inspections** – the contractor will regularly inspect, test, and maintain all safety equipment, scaffolds, guardrails, working platforms, hoists and other lifting equipment, ladders and other means of access, lighting and signage, firefighting equipment, first aid kit, stock take and condition of PPE etc. Signs will be graphic and in the languages of workers, kept clear of obstructions and legible to read. Lighting will meet illumination guidelines for the working area as per IFC EHS Guidelines on OHS. Equipment, which is damaged, dirty, incorrectly positioned or not in working order, will be immediately repaired, or replaced, by the contractor.
- **H&S Audit** - during construction the contractor's H&S officer and NESCO will undertake monthly audits of compliance with the H&S plan.
- **Personal Protective Equipment (PPE)** as a last resort where risks cannot be avoided – workers will be provided (before they start work) with appropriate PPE at no cost to the workers. PPE provided to workers (regardless formal and informal, directly contracted or subcontracted) in accordance with Table 2.7.1. Summary of Recommended Personal Protective Equipment according to Hazard in IFC EHS Guidelines on OHS including safety shoes, helmets, goggles, earmuffs, and face masks and ensure that this is always worn by them with a strict disciplinary system (no work condition if not compliant) being enforced for any non-compliance.
- **Work Zone Noise Levels:** during construction protective measures need to be

avoiding conditions for vectors to breed; contractors will also consider local health care facilities' capacity to deal with any infections agreeing with the nearest Health Center and/or Hospital for emergency cares of workers. Medical insurance will be provided by contractors for all workers with sick leave allowance to ensure symptomatic workers do not attend site; avoid no-work-no-pay policies, whereby by fear of not getting paid workers would be tempted to report to work and hide any symptoms.

provided and as per the IFC EHS Guidelines on OHS, Table 2.3.1. sets the level at 85 dB (A) for 8 hours exposure and will be adopted, as well as 140 dB(C) peak/instantaneous noise exposure for workers working near the high noise generating machinery. High noise work areas must be adequately signposted. In these high noise work areas PPE in the form of sound reducing earmuffs/ear plugs to the workers are to be provided. In the first instance however, reduction in noise levels to the lowest practical level must be achieved by adoption of suitable preventive measures, such as, use of enclosures with suitable absorption material, etc. Workers operating in the high noise work areas (e.g. with piling works) will be given auditory tests as part of health surveillance.

- **EMF levels** at the construction site to be kept within international good practice levels as per ICNRP (reference and peak values) for the occupational exposure.
- **Electricity:** IFC EHS Guideline on Electric Power Transmission and Distribution requirements for working with electricity will be observed with only licensed electricians that meet the requirements set out in them allowed to work on live electricity with strict adherence to safety standards including those listed in said guidelines. Live lines will be deactivated and properly grounded before work is performed on, or in proximity, to the lines and this will be checked and certified in writing by the contractor's H&S Officer in advance. While working at heights personal safety measures such as harnesses, tool bags, ropes etc. will need to be provided.

Traffic Management Plan. This plan will be prepared in consultation with the respective authorities responsible for roads and traffic. It will identify the off-site routes to be used, entrances and exits off the public road, procedures for the safety of the local community, particularly pedestrians and vulnerable groups, and mechanisms to avoid traffic congestion because of construction traffic movements. A designated person as the traffic controller, wearing coloured vest will be engaged for traffic management and be posted at the site entrance/egress.

Biodiversity Management Plan (as applicable) setting out procedures for site clearance requiring vegetation removal, tree cutting and earthworks with pre-checks and supervision undertaken by the Contractor's Environmentalist plus (i) construction worker prohibitions on fishing, hunting, poaching, etc. (ii) an emergency fauna rescue and handling procedure, including contacts of forest department, nearest veterinary etc. and (iii) measures to avoid the spread of invasive species including the installation of washing stations for the pressure washing of vehicles at construction site entrances.

Tree Plantation Plan: (as applicable) setting out details of trees to be lost and how the requirement for 1:3 compensatory plantation will be achieved. The plan will be prepared and finalized by the Contractor. The objective of the tree plantation and replacement program is to compensate for the loss of trees in construction. The species for the proposed tree plantation have been selected based on the statistics of the lost vegetation and in consultations with the concerned officials of the Forest Department (FD) of respective divisional office. The Contractor will be responsible for planting trees at the selected places as agreed by the PIU and PIAC. The Contractor will need to procure and raise saplings until they survive.

Chance Find Procedure setting out how damage to existing physical cultural resources will be avoided and the procedure to be followed in the event of a chance find incident.

Labor Management Plan addressing the recruitment and management of the workforce including details of sanitation and welfare facilities, construction labor camps or overnight

accommodation per ILO guidelines⁴ and a worker code of conduct⁵ to ensure workers have appropriate conduct whilst working and living in the local community. It will ensure compliance with the national labor law including that all workers whether formally or informally employed by the Contractor or their subcontractor(s) have a contract, identification card, the right to stop work, and do not work more than the legal working hours; it will discourage the use of daily workers by subcontractors and ensure adequate keeping of wage records. It will address the encouragement of local and women employment as well as measures needed to protect vulnerable worker groups including gender-based violence/sexual exploitation, abuse, and harassment prevention.

Emergency Preparedness Plan will be prepared by the Contractor after assessing all potential hazards and emergency scenarios that could be encountered in relation to pollution, health and safety, and security during construction to detail out how they will be quickly and effectively responded to.⁶

Stakeholder Engagement Plan to set out how the Contractor will interact with the local community and other stakeholders, issue advance notice of construction works, and disseminate the GRM, and manage site related complaints in line with the GRM for the Project.

Training Plan to set out how the Contractor will provide EHS training to its sub-contractors and all formally and informally employed workers on the construction site including daily tool box talks flagging their right to stop work if H&S risks are present, as well as awareness raising activities for the local community.

1.6 Environmental Code of Practices for Construction

20. The following ECPs (Annex 4) contain general, non-activity- or site-specific measures which need to be integrated into the Contractor's CSEMPs for implementation during the construction.

The list of ECPs prepared for the Project is:

- ECP 1: Waste Management
- ECP 2: Fuels, Oils and Other Hazardous Substances Management
- ECP 3: Water Resources Management
- ECP 4: Drainage Management
- ECP 5: Soil Quality Management
- ECP 6: Erosion and Sediment Control
- ECP 7: Top Soil Management
- ECP 8: Topography and Landscaping

⁴ https://www.ilo.org/wcmsp5/groups/public/---ed_emp/---emp_ent/---multi/documents/publication/wcms_116344.pdf with particular attention to providing one bed per worker and lockable storage

⁵ Code must be informed by the SEMP and address the following aspects: Zero tolerance in respect of health and safety; Requirement on always wearing PPE on site; Zero tolerance of bribery or corruption; Respect for local community and customs, avoiding community conflict situations; Zero tolerance of illegal and unacceptable activities/behavior, including but not limited to engagement in: prostitution; gender-based violence/sexual exploitation, abuse, and harassment; illegal sale or purchase of alcohol; sale, purchase, or consumption of drugs; gambling; fighting etc.; Alcohol and drugs policy and testing regime; Role of workers in good housekeeping; Role of workers in maintaining good hygiene; Respect of wildlife and the environment; Description of disciplinary measures for infringement of the code of conduct and other employer rules (e.g., immediate removal from site, fine etc.)

⁶ Including communication systems and protocols to report an emergency e.g., spills and leaks, health emergency, work-related accident including electrocution, traffic accident, accident involving the community, natural disaster including flooding or cyclones, fire, virus outbreak etc. It will need to be developed in consultation with local emergency services with adequate fire and first aid first-responders based on the construction site to facilitate immediate response. Provide readily available first-aid for workers as well as an ambulance for more serious cases. Make arrangements for a doctor on call and nearest Health Center and/or Hospital for emergency care of workers whether formally or informally employed by the Contractor or their subcontractors. Regular practice drills will be required involving all workers to prepare for any incident.

- ECP 9: Borrow Areas Management (note that borrow areas and dredging not permitted, only existing licensed sources are to be used)
- ECP 10: Air Quality Management
- ECP 11: Noise and Vibration Management
- ECP 12: Protection of Flora
- ECP 13: Protection of Fauna
- ECP 14: Protection of Fisheries
- ECP 15: Road Transport and Road Traffic Management
- ECP 16: Construction Camp Management
- ECP 17: Cultural and Religious Issues
- ECP 18: Workers Health and Safety including Labor Accommodation Requirements
- ECP 19: SF6 Management

21. Measures in the IFC EHS General and Electric Power Transmission and Distribution guidelines, ADB's Good Practice Guidance for the Management and Control of Asbestos: Protecting Workplaces and Communities from Asbestos Exposure Risks, the ILO Code of Practice on Safety and Health in Construction; and the ILO worker accommodation guidelines are to also be taken on board in preparing the CSEMPs.

1.7 Mitigation Plan

22. The Mitigation Plan sets out the plan for the avoidance, minimization, mitigation and compensation of impacts and risks during the following three phases:

- a. detailed design and pre-construction;
- b. construction (including demolition of required substations)
- c. operation and maintenance.

23. There are two parts to the Mitigation Plan,

- a. Part 1: General Mitigation (is applicable to all works components as specified therein)
- b. Part 2: Upgradation of 9 existing AIS substation (applicable to each of these components as specified therein)

24. The Mitigation Plan describes the general, activity- and site-specific mitigation measures to address the impacts and risks, which have been identified during the impact assessment, and ensure compliance with applicable national standards and international guidelines (Annex 2). Performance indicators to check that the measures are being implemented effectively are listed, along with the responsible entities for implementing them and supervising and monitoring their effectiveness (either NESCO, the PIAC and/or the Contractors). The Contractors will be contractually bound to implement these measures plus the more general ECPs by incorporating both into site-specific CSEMPs/H&S Plans and other subplans, as described in the following sections. Measures that must be commenced during the design and pre-construction phase will continue to be implemented by the Contractor during the construction phase.

25. Within the defects liability period of 1.5 years the Contractor will also be responsible for maintenance. Following that, NESCO will take over the responsibilities for both operation and maintenance.

1.8 Environmental Monitoring Plan (EMoP)

26. NESCO/PMU will be required to submit semiannual environmental monitoring reports reverting to annual upon operation up until the ADB project completion report is issued, along with submission of quarterly environmental progress updates (as part of the project's quarterly

progress reports). Environmental monitoring reports will be due by the 15th of the month following the period end. These reports will be disclosed on ADB's website and locally per the IEE.

27. The Environmental Monitoring Plan (EMoP) sets out the minimum requirements for quantitative monitoring and performance standards to be complied with during construction. The main purpose of this EMoP is to ensure that the various tasks detailed in the EMP, particularly the mitigation measures, are implemented in an effective manner and any unanticipated impacts on environment and social parameters can be promptly addressed.

28. Quantitative monitoring activities may be modified during project implementation, depending on the contractors' performance and analytical results obtained. If performance is worse than expected, corrective action/s will be identified, and environmental monitoring activities will be adjusted accordingly by NESCO and their Contractors during pre-construction, construction or the Operations and Maintenance (O&M) phase to help resolve any unsatisfactory performance.

29. In addition to quantitative monitoring there will also be supervision and monitoring of EMP implementation. Monitoring of this qualitative compliance with the EMP will be carried out with the help of checklists prepared based on the mitigation measures detailed in the Mitigation Plan.

c. There are two parts to the Monitoring Plan, as follows, Part 1: General Mitigation (is applicable to all works components as specified therein)

d. Part 2: Existing substation upgradation

2. Implementation Arrangements

2.1 Capacity Building and Training Requirements

30. NESCO has decided to form an Environmental and Social Safeguards Unit (ESSU) as part of the corporate organogram, but initially it will sit as part of the PMU with focals assigned to each permanent staff position whilst awaiting management approval. The ESS Unit set up will address environment, social and gender matters and be comprising of three focals and then staff, 1 environment focal/staff, 1 H&S focal/staff, and 1 social/gender focal/staff. They will undertake all safeguards related oversight actions on the project.

31. Support for ESSU on safeguards implementation in respect of supervision, monitoring and reporting is essential during the **4-year implementation period**. Thus, a capacity building component for institutional strengthening of NESCO's ESSU is included in the Project. NESCO will employ a Project Implementation Assistance Consultant (PIAC) who will support NESCO in implementing the environmental and social management requirements. However, since the overall responsibility of environmental and social management lies with the NESCO, they need to ensure that the consultants are carrying out their responsibilities properly. For this purpose, it is important that the NESCO engineers/officials of ESSU receive training on environmental management and monitoring requirements. Such training will assist them in properly overseeing the activities of the consultant engaged in environmental and social management of the project.

32. NESCO staff of PIU and the ESSU who will be working on the project will need to be provided with the appropriate training on environmental safeguards in general and the

specifics of management and monitoring requirements. The contractor's staff as well would also need some training and awareness raising to ensure they fully understand the EMP requirements. As such, a preliminary training program is being proposed to equip NESCO staff and contractor with the needed safeguards capacity. The training modules will be delivered through PIAC who will bring in technical expertise for any specialized trainings. The exception is the facilitated H&S workshop which will be attended by the PIAC but organized by the Contractor. Training modules may be changed during project implementation depending on the needs; ESSU will develop a training plan upon loan effectiveness to reconfirm requirements. Separate training and capacity building will be provided during the project implementation period.

Table 4: Key EMP Milestones in Implementation Schedule

| Training Session | Required Attendees/Recipients | Delivery Mode/Duration | Training Conducted by | Budget Source |
|--|--|---|-----------------------|-------------------|
| Introduction to ADB's Safeguard Policy Statement (2009), IFC EHS Guidelines, national requirements, and Project EMP including EMoP | PIU ESSU, Contractors' environmental safeguard team and PIAC' engineer | Lecture session, presentation, and discussion. In Person/ 1 day | PIAC | PIAC Budget |
| Corrective action for existing substations (good practices) | SS staff of NESCO, PIU, ESSU, and PIAC engineers. | Lecture session, presentation, and discussion. In Person/ 2 day | PIAC | PIAC Budget |
| EMP implementation for detailed design, development of CSEMP/H&S plans as well as all sub-plans | PIU, ESSU, Contractors' environmental safeguards team, PIAC engineer and Design Teams | Lecture session, presentation, and discussion. In Person/ 3 day | PIAC | PIAC Budget |
| Facilitated H&S workshop (detailed design stage) | PMU, ESSU, PIAC engineer, Contractors' Management, Design, Construction, and Environment Safeguards Teams, SS managers, and other O&M representatives of NESCO | Facilitated workshop. In Person/ 1 day | Contractor | Contractor Budget |
| Pollution control and waste management, including hazardous materials and waste management, | PMU, ESSU, Contractors' Management, Design, Construction, and Environment Safeguards Teams, SS and O&M representatives of NESCO | Lecture session, presentation, and discussion. Online/ 0.5 day | PIAC | PIAC Budget |
| PCB awareness raising | SS staff of NESCO, PIU, ESSU, PIAC engineers, Contractors' Management, Design Teams and Environment Safeguards Teams | Lecture session, presentation, and discussion. Online/ 0.5 day | PIAC | PIAC Budget |
| Asbestos awareness raising | SS and workshop staff of NESCO, PIU, ESSU, PIAC engineers, Contractors' Management, Design Teams and Environment Safeguards Teams | Lecture session, presentation, and discussion. Online/ 0.5 day | PIAC | PIAC Budget |

| Training Session | Required Attendees/Recipients | Delivery Mode/Duration | Training Conducted by | Budget Source |
|---|---|--|-----------------------|-------------------|
| GRM operation (initial run at start of project, and then again on handover to operational staff) | PIU, GRM Focal Points, ESSU, Contractors' Management and Focal Points, and other GRC committee members | Lecture session, presentation, and discussion. In Person/ 1 day | PIAC | PIAC Budget |
| EMP implementation for pre-construction and construction, including workshop on CSEMP preparation, review/discussion on implementation of CSEMP/ H&S plans as well as all sub-plans | PIU, ESSU Contractors' Construction and Environment Safeguards Teams | Lecture session, presentation, and discussion. In Person/ 3 day | PIAC | PIAC Budget |
| Facilitated H&S workshop (construction stage) | PIU, ESSU, PIAC, Contractors' Management, Design, Construction, and Environment Safeguards Teams, SS managers, and other O&M representatives of NESCO | Facilitated workshop In Person/ 1 day | Contractor | Contractor Budget |
| Environmental quality monitoring requirements; site supervision and monitoring including use of detailed monitoring framework (checklists) and preparing Environmental Monitoring Reports | PIU, ESSU Contractors' Management, Construction, and Environment Safeguards Teams | Lecture session, presentation, and discussion. In Person/ 2 days | PIAC | PIAC Budget |
| Facilitated H&S workshop (commissioning stage) | PIU, ESSU, PIAC engineers, Contractors' Management, Design, Construction, and Environment Safeguards Teams, SS managers, and other O&M representatives of NESCO | Facilitated workshop In Person/ 1 day | Contractor | Contractor Budget |
| EMP implementation at handover upon commissioning (site restoration and O&M) | PIU, ESSU, Contractors' Management and Environment Safeguards Teams, SS managers, and other O&M representatives of NESCO | Lecture session, presentation, and discussion. In Person/ 1 day | PIAC | PIAC Budget |

2.2 Implementation Schedule

33. Strictly no contracts will be awarded before the EMP cleared by ADB as disclosed on the ADB website has been incorporated into the contract documentation. If a draft of the EMP was included in the bidding documents for advanced contracting the disclosed version of the EMP will be incorporated into the contract documentation prior to contract award. Further, no site establishment or construction activity is to take place before NESCO has received and approved the contractor's CSEMP/H&S Plan including all necessary subplans.

34. The tentative implementation schedule of the project is listed in Table 5. The contractors will submit a more detailed implementation schedule for the detailed design, pre-construction, and construction once the contract is awarded.

Table 5: Key EMP Milestones in Implementation Schedule

| | Description | Indicative Time Frame |
|----------|---|---|
| 1 | Project Implementation | |
| A | Bidding Documents Approval | June 2025 |
| B | Procurement (Contract Award) | August 2025 |
| C | Construction commencement | |
| D | Construction Completion | September 2029 |
| E | Defects Liability Period | 1.5 years |
| 2 | Pre-Construction Phase | |
| A | Implementation of mitigation measures and conduct environmental monitoring for which NESCO is responsible | From loan effectiveness or start of advanced contracting whichever is sooner |
| B | Establishment of GRM | From loan effectiveness or contract award whichever is sooner |
| D | Appointment of the ESSU staff to the PIU of the project, nomination of focals for EHS on site | From loan effectiveness or contract award whichever is sooner |
| E | Appointment of PIAC | From loan effectiveness or contract award whichever is sooner |
| F | Implementation of mitigation measures and conduct of environmental monitoring for which contractor is responsible | Upon award of the contract |
| G | Updating the IEE/EMP to reflect detailed design and obtaining ADB clearance of the updates to these as required | Prior to approval of the detailed design |
| H | Submission and approval of the Contractor's Specific Environmental Management Plan (CSEMP), H&S Plan | One month before the start of works including any site establishment, site preparation, demolition, and earthworks |
| 3 | Construction Phase | |
| A | Implementation of mitigation measures and conduct of environmental effects monitoring following the EMP and EMoP. | After award of the contract |
| B | Monthly Progress Report (EHS) | 7th day after effective month (covering the month prior) |
| C | Semi-Annual EMR during construction for submission to ADB | 15th day after end June or December once loan has been effective for at least one full quarter, the last construction EMR will be submitted after the commissioning and DLP of all works documenting in depth how all pre-construction and construction |

| | Description | Indicative Time Frame |
|----------|--|---|
| | | activities were complied with |
| D | Restoration of construction sites | Before demobilization of contractor |
| 4 | Operation Phase | |
| A | Implementation of mitigation measures and monitoring activities for operational period | Upon commissioning and the handover to NESCO |
| B | Annual EMR during construction for submission to ADB | First operational EMR will be submitted 12 months after the last construction EMR was submitted up until the ADB PCR is issued. |

2.3 Cost Estimate / EMP Budget

35. Costs will be associated with implementation of the Mitigation Plan, the EMoP and capacity development. The provisional breakdown for the EMP implementation cost is given in Table 6.

36. Necessary budgetary provisions must be planned and allocated by NESCO and competitively bid by the PIAC and contractor for their scope of work. The main EMP budget items have been identified, and an indicative budget allocated for each. The budget will be refined during project implementation but enables preparedness for financial requirements. For NESCO counterpart finance about will be required for construction. For PIAC and contractor related costs these are only an estimate based on an estimate of the construction and installation cost, since the contracts are subject to competitive bidding it will be for the contractor/consultants to reflect in their BOQ and ensure adequate budget is provided in their bids for the EMP implementation.

37. The construction EMoP will be part of the Contractor's contract, whereas the operational EMoP will be the responsibility of NESCO O&M team.

38. Operational cost is an annual cost; it will be incurred annually for each year of operation.

39. Separate training and capacity building will be provided in relation to the Project outcome to enhance the capacity of the ESSU – the cost of the safeguard implementation consultant is costed separately to the EMP budget/cost

Table 6: EMP Implementation Budget for the Project (Construction)

| GD 6: 9 AIS station upgrade | | | | | |
|---|-----------------|---------------------|---------------------|---|------------------------|
| Item | Unit cost (BDT) | Monitoring schedule | Annual budget (BDT) | Total Environment Mitigation Cost (BDT) for two years | Responsible Party |
| A. NESCO Staff | | | | | |
| EHS Training | | Quarterly | | | NESCO through PIAC |
| CAP Implementation Plan | Lump-sum | Annual | | | NESCO through DPP |
| B. PIAC Staff | | | | | |
| C. Contractors Staff | | | | | |
| Environmental Monitoring Officer(s) | | Monthly | | | Contractor through BOQ |
| Health and Safety Monitoring Officer(s) | | Monthly | | | Contractor through BOQ |
| D. Mitigation Budget for Construction Period | | | | | |
| Waste Management (SWM, Hazardous, PCB, Asbestos survey and management (if any), sewage, drainage) | Lump-sum | Annual | | | Contractor through BOQ |
| Labor Camp Cost (including costs for drinking water, sanitation, and community liaison to prevent disputes) | Lump-sum | One time | | | Contractor through BOQ |
| Noise Management | | Quarterly | | | Contractor through BOQ |
| Dust Management | | Quarterly | | | Contractor through BOQ |
| Drainage Congestion | | Quarterly | | | Contractor through BOQ |
| STD/AID/Communicable Diseases Protection | | Quarterly | | | Contractor through BOQ |
| Drinking Water | | Quarterly | | | Contractor through BOQ |
| Tree Plantation & Maintenance | | One time | | | Contractor through BOQ |
| Stakeholder Engagement Plan | | Monthly | | | Contractor through BOQ |
| PPE and safety tools/kits provision to SS | Lump-sum | Annual | | | Contractor through BOQ |
| Sign Board | Lump-sum | Annual | | | Contractor through BOQ |
| Fire Safety | Lump-sum | Annual | | | Contractor through BOQ |
| Safety and Security | Lump-sum | Annual | | | Contractor through BOQ |
| Natural Disaster Management | Lump-sum | Annual | | | Contractor through BOQ |
| Accident/Incident management plan | Lump-sum | Annual | | | Contractor through BOQ |
| Environmentally Sensitive Area | Lump- | Annual | | | Contractor through |

| GD 6: 9 AIS station upgrade | | | | | |
|---|-----------------|---------------------|---------------------|---|------------------------|
| Item | Unit cost (BDT) | Monitoring schedule | Annual budget (BDT) | Total Environment Mitigation Cost (BDT) for two years | Responsible Party |
| Ecology Study | sump | | | | BOQ |
| Soil remediation | Lump-sump | Annual | | | Contractor through BOQ |
| E. Monitoring Budget for Construction Period | | | | | |
| Laboratory Analysis for Environmental Quality Monitoring (Ambient Air Quality Parameters, Surface Water Quality Monitoring, Ground Water Quality, Soil Pollution, Electro Magnetic Field) | | Quarterly | | | Contractor through BOQ |
| Sub-Total | | | | TBC | |
| F. Monitoring Budget for Operation & Maintenance Period | | | | | |
| Natural Disaster Management | Lump-sump | Annual | | | NESCO through DPP |
| Accident/Incident management plan | Lump-sump | Annual | | | NESCO through DPP |
| Sub-Total | | | | | |
| Grand Total | | | | | |

Note:

- Contractor BOQ costs for Environment included in BOQ estimate

2.4 Supervision, Monitoring and Reporting Arrangements

40. NESCO will submit environmental monitoring reports to ADB on a semi-annual basis up until the completion of construction and on an annual basis during operation, within 15 days from the end of each reporting period i.e., June and December. Submission of environmental monitoring reports will be required from loan effectivity. In between, NESCO will submit quarterly progress reports including an update on environment safeguards implementation following the template in the PAM.

41. The Contractor's EHS management team will establish their own internal systems for supervising, monitoring and reporting their EMP implementation. During the design, pre-construction and construction phases, contractors shall prepare and submit monthly EHS progress reports per an agreed template to the PMU of NESCO which will form part of their quarterly progress reports and the quarterly progress and semi-annual monitoring reports to be submitted to ADB by NESCO. The monthly EHS progress reports shall indicate any design changes made by the Contractor from the project as assessed in the IEE, and the Contractor's performance (including the performance of all their sub-contractors and any third parties) during pre-construction and construction regarding environmental safeguards implementation. The Contractor will also attend monthly meetings convened by NESCO to discuss EHS issues and establish a H&S Committee including worker representation who will also meet on a monthly basis.

42. The environmental monitoring reports of NESCO will describe the physical progress of the project, any scope or design changes, compliance with the loan covenants with regard to safeguards, implementation of mitigating measures described in the EMP, quantitative monitoring data and analysis, GRM implementation, and any noncompliance issue and

corresponding corrective actions. Once cleared by ADB's environment specialists, the monitoring reports will be posted on ADB's website as required by its Safeguard Policy Statement (2009) and ADB's Access to Information Policy and disclosed by NESCO on its website and locally to the communities through notices boards, leaflets, brochures, or handouts.

43. In the event of any unanticipated environmental impacts including location, route, design or scope changes during implementation, or if monitoring identifies a breach of performance standards that should be complied with by NESCO and/or their Contractors, Contractors must inform NESCO if they are the ones to become aware of such a situation. NESCO will immediately need to inform ADB, assess the significance of such impacts, evaluate the options available to address the unanticipated impact, and submit to ADB a time-bound and budgeted corrective action plan or updates in the IEE/EMP for review and clearance as required.

44. Complete photographic records and documentary records will be kept by the Contractors covering all activities on the construction site as well as key locations such as receptors adjacent to substations, off-site access roads, construction stores, sanitation and welfare facilities, labor camps, or overnight accommodation etc. Photographs and condition surveys of all key locations will be taken prior to construction activities beginning, to provide the environmental baseline. Copies of all geo-referenced photographs/condition surveys will be submitted to the PMU along with the contractor's monthly EHS progress report. Specifically, the Contractor will be responsible for the documents and reports in Table 7. Documentation and records to be kept by all parties in hard copy as well as electronic format are as follows (not an exclusive list):

- National IEE
- Definitive ADB IEE/EMP (as disclosed on the ADB website)
- Legal register (of all applicable national legislation)
- Tree felling permits, vehicle emission test certificates etc.
- Training plan and training records with attendance records and photographs of the trainings
- Stakeholder engagement plan and records of all consultations undertaken with photographs and attendance records
- Records of emergency preparedness and response drills with photographs and attendance records
- Document review and approval records
- CSEMPs/H&S and other sub-plans and copies of approval records
- Contractor (subcontractor) certifications and insurances
- Contractor (subcontractor) worker records including documentation of working hours
- Completed site checklists and photographic records
- Non-compliance notifications and corrective action instructions
- Contractor and operational accident record and incident reports
- GRM register

45. NESCO and their contractors will facilitate ADB to carry out the following monitoring actions to supervise project implementation:

- Conduct periodic site visits during the project implementation to confirm compliance with the ADB's Safeguard Policy Statement 2009, the project's loan covenants and EMP requirements.
- Review and comment on the periodic EMRs submitted to ensure that adverse impacts and risks of the project are mitigated as was planned and agreed with ADB, that any corrective actions required have been duly implemented, and that the GRM is fully functional.
- Work with NESCO to rectify to the extent possible any failures to comply with their safeguard commitments, as covenanted in the loan agreement, and exercise remedies

- to re-establish compliance as appropriate.
- Prepare a project completion report that assesses whether the objective and desired outcomes of the EMP have been achieved, considering the baseline conditions, and monitoring results.

46. For this purpose, NESCO and their contractors will provide ADB with access to the project site and all requested information on the project. For any ADB supervision missions NESCO or their contractors will provide all ADB staff with a project site health and safety induction and adequate PPE in accordance with Table 2.7.1 of the WBG IFC EHS General Guidelines - Occupational Health and Safety Section and ILO guidance on Safety and Health in Construction.

Table 7: Main Documents Required from NESCO and Contractor

| Documents | Originator | Destination of the documents | Submission Timing | | |
|---|------------|------------------------------|---|--|------------------|
| | | | Design and pre-construction period | Construction period | Operation period |
| Bid and contract documents including EMP requirements | NESCO | ADB | X (Once, prior to the issue and on award) | | |
| Training Plan | PIAC | NESCO | X (Once, prior to the design approval) | | |
| Stakeholder Engagement Plan | PIAC | NESCO | X (Once, prior to the design approval) | | |
| Health and Safety Risk Assessment | Contractor | PMU and PIAC (ESSU) | X | X (at minimum annually updated and upon commissioning for handover to NESCO) | |
| Pre-construction baseline monitoring reports | Contractor | PMU and PIAC (ESSU) | X (Once, prior to the start of construction) | | |
| Updated IEE for changes in sub-projects | NESCO | ADB | X (Once, prior to the design approval if it is required) | | |
| Final design for approval | Contractor | PMU and PIAC | X (Once, prior to the start of construction) | | |
| CSEMP, H&S including other subplans for approval (including subplans) | Contractor | PMU and PIAC (ESSU) | X (Once, prior to the start of construction) | X (Updated through construction as needed/reviewed monthly) | |
| Environmental, health and | Contractor | PMU and | | X | |

| Documents | Originator | Destination of the documents | Submission Timing | | |
|---|----------------------------|---|--|---|--------------------------------|
| | | | Design and pre-construction period | Construction period | Operation period |
| safety checklists including worker accommodation | | PIAC (ESSU) | | (Every week, to be completed daily) | |
| Environmental, health and safety checklists including worker accommodation | PIAC | PMU (ESSU) | | X (Weekly checks of active construction sites, at least monthly visits to each contract package) | |
| Monthly EHS progress reports including EMoP results and records and record of monthly training and daily toolbox training plus incident records and grievances | Contractor | PMU and PIAC (ESSU) | X (Every month) | X (Every month) | |
| Monthly EHS progress reports on status of EMP implementation and observations from site visits, minutes of site EHS meetings, incident records, grievances etc. | PIAC | PMU (ESSU) | X (Every month) | X (Every month) | |
| Lost time and fatality incident reports | Contractor NESCO O&M | PMU and PIAC (ESSU) Onward Submission to ADB | | X (24 hours) | X (24 hours) |
| Environmental Monitoring Report | PMU (ESSU) | ADB | X Semi-annually from loan effectiveness | X Semi-annually | X Annually until PCR issued |
| Completion Report | PMU (ESSU) | ADB | | | X |

2.5 Implementation Arrangements

2.5.1 Government of Bangladesh

47. The Ministry of Power, Energy and Mineral Resources (MPEMR) is the main Project coordinating body on behalf of government.

2.5.2 NESCO's Management, PMU, PIU and O&M Staff

48. The overall responsibility for environmental and social performance of the project, implementation of the EMP and approving the detailed designs, CSEMP, H&S Plan, and subplans will rest with NESCO. NESCO has already established a dedicated PMU to lead Project implementation. **The PMU is headed by a Superintending Engineer with 5 Executive**

Engineers from Design & Inspection, Procurement and System Planning department of NESCO; 1 Deputy General Manager from ICT division; 1 Deputy Manager from ICT, 5 Subdivision Engineers from Rangpur Project, Rajshahi Project, Smart Meter Project, Civil Dept. of NESCO; 2 Assistant Engineers. PMU will be supported by the ESS Unit. A key role of the PMU/PIU is to supervise and monitor environmental safeguards compliance and report to ADB. NESCO need to ensure sufficient PMU staff and budget resources are assigned to safeguards to implement, supervise, and monitor the EMP as per the roles and responsibilities set out therein.

49. Individual PIU(s) will manage each contract package and will have a team of engineers assigned to it for full time supervision, including day-to-day supervision of environment, health and safety with support of ESSU and PIAC. One local engineer must be nominated as EHS site supervisor for each active work site to check on EHS implementation daily and report back issues. The level of input required over the project implementation period needs to be sufficient to undertake daily site checks, ensure contactor compliance and well prepared EMR etc. The subdivision and assistant engineers assigned to each contract package can be responsible for ensuring day-to-day checks are undertaken but the role should be assigned separately so to ensure focus on EHS aspects rather than on doubling up with having to manage engineering matters. They and the EHS site supervisors will need on-the-job training regarding safeguards issues.

50. A key role of the PMU/PIU is to supervise and monitor environmental safeguards compliance and report to ADB up until issue of the project completion report. On commissioning of the project components these will be turned over to NESCO O&M staff to operate and maintain. NESCO O&M workers will need to abide, in their behaviour and work, to directives issued by their employer with regards to environmental, health and safety management.

2.5.3 NESCO's Environment and Social Unit (ESSU)

51. Until it can be staffed by full time qualified and experienced staff, anticipated to be 1-2 years after loan effectiveness the Environment and Social Unit (ESSU) will initially comprise of 3 engineers who will be delegated to serve as the focals. As engineers they have no safeguards capacity to address either environment and social safeguards but they will be required to assist PMU on issues related to environmental and social management and supervise the Project Implementation Assistance Consultant and contractors. Given their capacity and that there are several project components distributed over the two divisions, it is unlikely they alone can ensure the oversight required for satisfactory safeguard implementation. In addition, to PIAC an environment consultant and a social consultant will support ESSU during project implementation until it can be staffed by full time qualified and experienced staff.

52. The ESSU will review the regular monthly progress reports of the contractor and PIAC on EMP compliance, reports are to be sent to the Project Director of the Project Management Unit (PMU) throughout the construction period. They will also review the semi-annual environmental monitoring reports produced by the PIAC during construction and be responsible for preparing the annual environmental monitoring reports once operational for submission to ADB.

53. Safeguards Implementation Consultants (PIAC) will support PMU and ESSU to supervise and monitor the construction contractors to ensure design compliance and quality assurance of the construction activities. The PIAC, will help ESSU supervise the contractors for CSEMP and H&S Plan implementation and must be present on all active construction sites.

54. The contractors in turn will also have environmental, health & safety (EHS) officers and Environmentalists (as needed) who will be tasked to first develop CSEMP and H&S Plan in accordance with the present EMP and then responsible for its implementation during construction activities. The ESSU with help from PIAC will support the PMU to approve these plans.

55. Capacity development will be required to build up the environmental and social management capabilities of the PMU and ESSU with help from PIAC funded under the capacity building component of the Project, support the development of EHS standard operating procedures for substations and workshops etc.

56. Specifically, for this project, the ESSU staff will be delegated to work as part of the PMU (reporting to PD) to support EMP implementation, supervision, monitoring and reporting. A key role of the ESSU will also be to manage the Grievance Redress Mechanism (GRM) at project level on behalf of the PMU. The ESSU staff will be given authority to instruct the PMU and be given delegated authority to instruct the Contractor to undertake corrective action in relation to any lapses in compliance with national laws and regulations or the EMP implementation.

57. The ESSU will assist the PMU on issues related to environment, health and safety, labor and social management and work together with the PIAC and Contractors' EHS staff. Contractors will submit progress reports on environment, health and safety and social issues to the PMU monthly during the pre-construction and construction period. The ESSU technical staff and PIAC will review them and report any issues to the PMU, compile quarterly environment safeguards implementation updates to be shared with the ADB through the quarterly progress reports, as well as preparing the semi-annual environmental monitoring reports with PIAC on behalf of PMU up to the end of construction and then on an annual basis during the operation phase.

58. During operation, ESSU will continue to ensure and report on EMP implementation by the NESCO O&M staff and be responsible for the annual environmental monitoring report submission.

59. The ESSU will provide facilitation support to the PIAC in providing environmental training to the PMU staff and contractors responsible for implementing the EMP during the construction phases of the project.

60.

2.5.4 Project Implementation Assistance Consultant (PIAC)

61. The PMU will engage a Project Implementation Assistance Consultant (PIAC) to be financed by NESCO with inputs required for the individual experts and their responsibilities for supervision of construction contractors. PIAC will ensure compliance with safeguards documentation – IEE/EMP, CEMP, H&S Plan and other sub-plans while adhering to detailed design standards and to assure the quality of the construction activities by all contractors. The PIAC will also support the updating of the IEE in response to final designs of the contractor before work can be started.

62. The PIAC will also include consultants to supervise the contractors on EMP implementation. For this purpose, PIAC will engage one Environmental Specialist 15 PM, one Health and Safety Specialist with NEBOSH/IOSH for 15 PM, one Social Development Specialist (Stakeholder Engagement and Labor) 15 PM on an intermittent basis with weekly checks undertaken of active construction sites. Other technical experts were brought into the

PIAC team as required to address the EMP requirements. The level of input required over the project implementation period needs to be sufficient to ensure weekly and monthly site checks, updating of the IEE etc.

63.

2.5.5 Contractor and Subcontractors (if any)

64. The Contractor is responsible for the implementation of the EMP with supervision and monitoring by the PMU and PIAC supported by the ESSU staff. The requirement to undertake relevant mitigation and monitoring actions as set out in the EMP applies to the construction site as well as off-site locations such as construction stores and at any labor camps or overnight accommodation provided. The contractor is required to ensure that the EMP requirements are cascaded down to all sub-contractors undertaking work regardless of whether they are formally or informally employed. It is recommended the EMP be included in all subcontracts and the number of subcontractors in the chain be minimized to facilitate compliance with EMP requirements.

65. All construction workers, whether formally or informally employed, will need to abide, in their behaviour and work, to directives issued by their employer with regard to environmental, health and safety management.

66. Contractors will have a corporate EHS policy and environmental management certification preferably ISO 14001 (or equivalent) and EHS certification such as ISO45001 or equivalent.

67. The Contractors for Package 6 will include the following dedicated, full-time, site-based staff on their EHS team: (i) Environmental Specialist (including with expertise in Pollution Control including oil management), (ii) Health and Safety Specialist, (iii) Social and community liaison officer, (iv) Labor officer, and (v) EHS Site Supervisors. The following dedicated, part-time, site-based staff are needed for full time supervision as the appropriate stage in the works with intermittent inputs during other times. Other technical experts e.g., asbestos surveyor will be brought into the EHS team as and when required to address the EMP requirements. The contractor will provide one EHS Supervisor for each sub-project site under construction. This person will be based on-site full-time to ensure the health and safety of all workers and local communities. The EHS Supervisor will act as the main contact for the EHS Team and act on its advice regarding EMP implementation. If there is more than one active site or the construction team at a site comprises more than 50 persons, each EHS Supervisor will be supported by additional full-time, dedicated, on-site Health and Safety steward(s). There should be at least one full-time on-site supervisor/steward for each active site and construction team of up to 50 people. For the construction works a suitable number of Health and Safety Steward(s) will be required depending on how the contractor undertakes the work since the workers may be more dispersed compared to substation works. No work should be undertaken without H&S supervision.

68. If a contractor is awarded more than one contract package, then an entirely separate EHS team is to be employed for each of them. Contractors are to also ensure their subcontractors appoint an EHS representative for each construction site; their own supervision input will need to reflect that subcontractors need close supervision and monitoring to ensure EMP compliance.

69. The EHS Team will be tasked to develop the CSEMP, H&S Plan and subplans in accordance with the EMP and be responsible for ensuring its implementation during the construction activities, supported by enough 24-hour [only during working shifts so if no night

shifts no nighttime input required] onsite EHS Supervisors/H&S stewards. During construction, the EHS team will continually update the CSEMP, H&S Plan and subplans and oversee and report to PMU on the operation of the Project EMP/CSEMP/H&S Plans throughout the contract period.

Contractor Staffing

70. The Environmental Specialist, will be the Contractor's main focal point for all environmental, social, health and safety issues associated with the Project. He/she will be a suitably qualified and experienced full-time member of staff and must be on site at least five days per week with an alternative available during periods of annual or sick leave of more than 1-2 days. The required qualifications of the role of Environment Specialist are as follows:

- BSc and MSc degree in environmental sciences or related subject.
- At least 15 years of experience in environmental assessment and management planning including for electrical infrastructure projects
- At least 10 years of on-site environment supervision, including experience of EMP implementation on at least five construction/electrical infrastructure projects of a similar type, location, size and scale
- Experience of pollution control including oil, PCB and SF6 management and the design of transformer bunds and hazardous material storage areas for substations will get preference.(a separate pollution control officer to the environment specialist to meet this criteria may be provided, the contractor will bear the cost of it).

71. Specifically, the Environment Specialist shall be responsible for the following:

- Identifying any areas of environmental sensitivity to be avoided with the support of field Environmentalists.
- Translate mitigation requirements written in the SCC/ECC/Project EMP into developing CSEMP/H&S Plans and their sub-plans and then into practical measures on the ground.
- Ensure that all contractor management, subcontractor management, and construction workers are fully aware of the environmental sensitivities of the sites and their responsibilities, as outlined in the Project EMP/CSEMP/H&S/SCC/ECC (e.g., through back-to-back contract provisions, formal induction and training provision, daily toolbox talks ahead of construction works etc.).
- Supervise construction works with regular site walkovers and spot-checks (audits) of compliance, take field notes and photographs to demonstrate compliance or non-compliance with the Project EMP/CSEMP/H&S plans and its sub-plans/SCC/ECC.
- Participate in monthly meetings with the PMU, PIAC and ESSU to discuss EMP implementation progress and any EHS concerns,
- Coordinate completion of quantitative environmental monitoring in accordance with the EMoP requirements.
- Maintain environmental records e.g., training records, EMoP results, waste records etc.
- Act as the contractor's GRM focal to keep affected persons informed of work and be available to receive and deal with any grievances at the project site level. The H&S and Social, Community Liaison and Labor Officers will help with managing all social and labor related grievances. They will also act as the GRM focals for workers receiving and recording grievances in the logbook.
- Prepare weekly environmental checklists and monthly EHS progress reports that shall be submitted to PMU (ESSU) for review. The PIAC will provide a template of the checklist to the contractor, the monthly reports will also include general progress with the project and EMP implementation with photographs, regular site visits and spot checks (audits) undertaken, training provided, environmental incidents, e.g., spills of liquids, health and safety incidents, progress with any environmental initiatives, e.g., energy savings, recycling, community awareness etc., records of any environmental monitoring, conclusions and recommendations (corrective action), impacts on unanticipated changes in projects etc.
- Conducting the ecology surveys which are the responsibility of the contractor including bird survey during appropriate periods round the year for the migratory and local birds in the project area and preparing report.
- Identifying any areas of environmental ecological sensitivity to be avoided.
- Preparing the Biodiversity Management Plan/Tree Plantation Plan.

- Ensure that all contractor staff and construction workers are fully aware of the ecological environmental sensitivities of the sites and their responsibilities, as outlined in the Project Biodiversity Management Plan/Tree Plantation Plan.
 - Periodically supervise construction works with spot-checks (audits) of compliance, take field notes and photographs to demonstrate compliance or non-compliance with the BMP/Tree Plantation Plans. To issue internal stop notices to construction workers, if necessary, for unsafe activities that adversely impact sensitive ecology of the PIA.
 - Participate in monthly meetings with the PMU, PIAC and ESSU to discuss BMP/Tree Plantation implementation progress and any concerns.
72. The qualifications for the H&S Specislist are:
- BSc and MSc degree in health and safety or related subjects.
 - National Examination Board in Occupational Safety and Health (NEBOSH) or Institution of Occupational Safety and Health (IOSH) certification or similar.
 - At least 10 years of experience in health and safety risk assessment and management planning including for electrical infrastructure projects
 - At least at least 5 years on-site H&S supervision experience including risk assessment and management planning for at least five construction/electrical infrastructure projects of similar type, location, size, and scale.
73. The main responsibilities of the H&S Specialist will be:
- Facilitate H&S Risk Assessments for detailed design and for specific construction work activities.
 - Produce H&S Plans for the construction work with subplans for specific construction work activities.
 - Provide H&S training, including effective daily toolbox training sessions at each work site with the support of sufficient numbers of 24-hour onsite EHS Supervisors and H&S Steward(s).
 - Participate in monthly meetings with the PMU, PIAC and ESSU to discuss EMP implementation progress and any EHS concerns,
 - Establish a H&S/Labor Committee including appropriate representatives from NESCO, PIAC, contractor and subcontractor management, and a representative number of construction workers and hold monthly meetings together with the Social, Community Liaison and Labor Officers to address any concerns,
 - Conduct routine site inspections and issue internal stop notices, if necessary, for unsafe activities.
 - Maintain H&S statistics records for near misses, as well as incidents.
 - Keep records of incidents and report them accordingly with lessons learned to avoid future repeats.
 - Undertake awareness raising activities to make the community aware of the H&S risks posed by the Project.
 - Preparation of weekly H&S checklists and provide H&S input to the Contractor's monthly EHS progress reports.
 - Support the Environment Officer as a GRM focal for workers receiving and recording grievances in the logbook.
74. The qualifications for the Social Community Liaison Officer are:
- BSc degree in social sciences and related expertise.
 - At least 10 years of experience in stakeholder engagement
 - At least at least 5 years of on-site stakeholder engagement experience including experience of construction/electrical infrastructure projects of similar type, location, size, and scale.
75. The main responsibilities of the Social, Community Liaison Officers will be:
- Produce stakeholder engagement plans for the construction work
 - Develop community awareness raising materials and lead on the delivery of community awareness raising activities.
 - Participate in monthly meetings with the PMU, PIAC and ESSU to discuss community awareness and stakeholder engagement progress and any community concerns,
 - Participate in the H&S Committee and hold monthly meetings together with the H&S Officer,
 - Support the Environment Officer as a GRM focal for stakeholders receiving and recording grievances in the logbook.
76. The qualifications for the Labor Officer are:

- BSc degree in social sciences and related expertise.
- At least 10 years of experience in labor management planning
- At least 5 years of on-site labor management experience including experience of construction/electrical infrastructure projects of similar type, location, size, and scale.

77. The main responsibilities of the Labor Officer will be:

- Produce labor related management plans for the construction work
- Ensuring management of construction workers is per national requirements with labor camps and other contractors provided accommodation meeting international good practice standards of ILO.
- Develop code of conduct and provide code of conduct training, including regular toolbox training sessions at each work site.
- Maintain labor records including copies of insurances, contracts and working hours, eligibility of construction workers for employment etc.
- Participate in monthly meetings with the PMU, PIAC and ESSU to discuss EMP implementation progress and any labor concerns,
- Participate in the H&S/Labor Committee and hold monthly meetings together with the H&S Officer,
- Preparation of weekly sanitation and welfare facility checklists and provide labor input to contractors monthly EHS progress reports.
- Support the Environment Officer as a GRM focal for workers receiving and recording grievances in the logbook.

Institutional Structure and Responsibilities

78. The organogram of the PMU, including ESSU, is shown in the following figure, which depicts the institutional arrangement - the responsibilities of NESCO's PMU (ESSU) as well as the PIAC and construction contractor(s). The roles and responsibilities of the PMU, ESSU, Consultant Team and contractor for the implementation and monitoring of EMP have been outlined in Table 8.

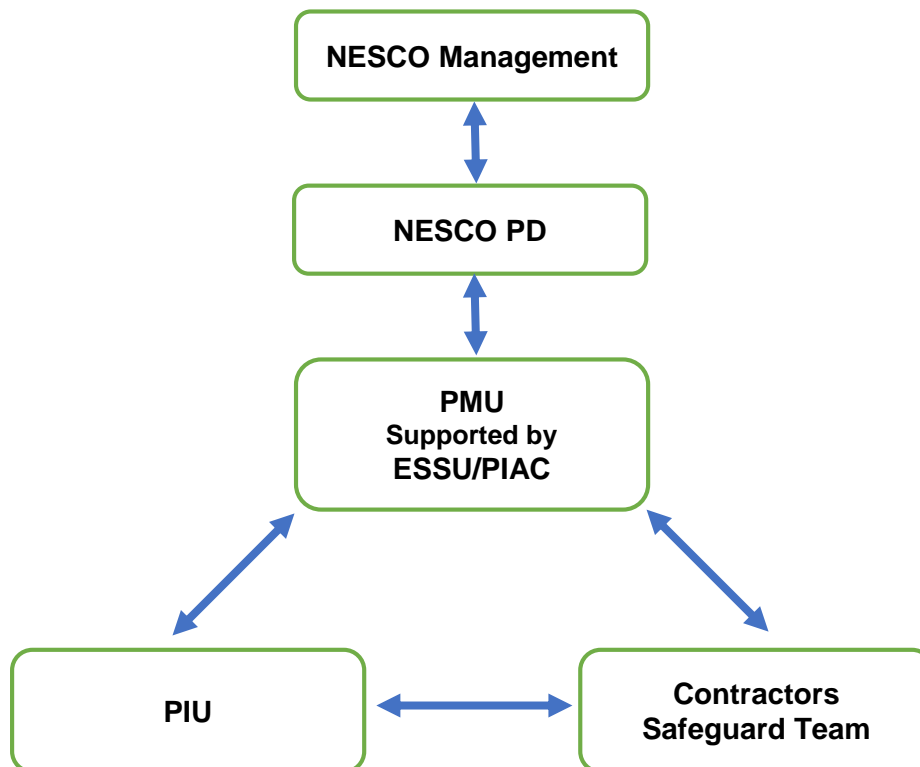

Figure 2-1: Project implementation organogram

Table 8: Roles and Responsibilities for EMP Implementation

| Organizations | Responsibilities |
|------------------|--|
| NESCO Management | <ul style="list-style-type: none"> Appointing ESSU within NESCO to the project as a constituent part of PMU to support EMP implementation during construction and operation and expanding the staffing inside of two years of loan effectiveness. ESSU focals will initially be engineers designated to perform safeguards requirements for ADB. However, ADB requires ESSU to be staffed with suitably qualified and experienced environmental, social, and health and safety matters to ensure implementation of safeguards across NESCO operations. Additional staff or consultants may be engaged by the ESSU full-time or intermittently, as needed to support. Ensuring adequate management support, budget, staff, and other resources are allocated to satisfactorily implement, supervise, and monitor implementation of the EMP during all phases. Ensuring that all PMU (ESSU) and O&M staff support and attend all capacity development and training activities provided for them. Adopting a zero-tolerance approach to H&S and developing and adopting systems, institutional arrangements, and guidelines (standard operating procedures) to ensure compliance with national environment, health and safety, social and labor laws and regulations and international good practice across NESCO operations and its projects. Once operational, any contractors hired for maintenance works or decommissioning will be supervised and monitored by NESCO (ESSU) with roles and responsibilities being the same as those of the contractors for the construction. Ensure that monitoring reports (semi-annual during construction and annual during O&M phase) are submitted to ADB up until the project completion report is issued. |
| PMU | <ul style="list-style-type: none"> Ensure effective implementation of construction of the project in accordance with the |

| Organizations | Responsibilities |
|---------------|--|
| | <p>definitive EMP. Seek the support of ESSU for updating the IEE/EMP subject to ADB review and clearance because of any location, route, design or scope changes.</p> <ul style="list-style-type: none"> • Ensuring adherence to all applicable national environment, health, safety, and labor laws and regulations in force at the time. • Ensuring adherence to ADB's Safeguard Policy Statement (2009), the related IFC Environment, Health and Safety (EHS), general and power transmission and distribution guidelines (2007) and the ILO Safety and Health in Construction guidelines (2022). • Ensure all labor accommodation is provided per the ILO workers accommodation guidelines. • Recruitment and supervision of Project Implementation Assistance Consultant (PIAC). • Incorporating the EMP into the bidding and contract documents before issuing tenders and contract awards. • Reviewing bids to ensure they are in accordance with the EMP requirements prior to contract award. • Ensuring the IEE with at least the executive summary translated into Bangla is disclosed on the NESCO website with hard copy available at construction sites and full translation free of charge into Bangla if it is requested by the public, publishing the key findings and availability through notices boards, leaflets, brochures, or handouts. • Reviewing and approving the contractor's detailed designs as well as CSEMP/H&S Plan and subplans to ensure they incorporate and are in accordance with the EMP requirements. • Implementing the EMP throughout all phases or, if responsibilities are delegated, supervising, and monitoring its implementation by the contractor with support of ESSU. • Ensuring all necessary national permits and permissions, and any requirements for renewal, are complied with before the commencement of related work, maintain records with copies of all the clearances, permits, licenses, and insurances obtained. • Ensuring the contractor provides adequate training to their subcontractors and all workers including daily EHS toolbox talks and emergency response drills; suggesting topics for the training based on site observations. • Undertaking, with the support of ESSU and PIAC, monthly EHS meetings including site walkover inspection to determine the status of EMP implementation by the contractor during construction as well as random "spot check" site visits to audit their EMP implementation. Minutes of meetings and findings of site walkover inspections will be attached to the EMRs to be submitted to ADB. • Identifying areas for improvement, unsafe acts, and any noncompliance with the EMP by the contractor and/or NESCO staff and instructing corrective actions to be taken by them to bring implementation back on track. • Thoroughly investigating all unanticipated impacts, near-misses, incidents, and chance finds; preparing a detailed incident report where applicable, identifying and instructing on corrective actions particularly to avoid any repetition of near-misses and accidents. • Monitoring and reporting with support of ESSU on EMP implementation include reporting on EMP implementation in quarterly progress reports and preparing semi-annual EMRs for submission to ADB up until the completion of construction, reverting to annual up until the ADB project completion report, or for longer period if it is required by the ADB PCR. • Reporting to ADB of any noncompliance or breaches with ADB safeguard requirements in a timely manner and take corrective actions promptly. Developing and taking all requisite corrective action in case of any noncompliance with the EMP including repair of any property damage and financial compensation (insurance) for health and safety incidents. • Reporting any unanticipated impacts, accidents, and chance finds to ADB within 48 hours of them occurring along with a corrective action plan. • Reporting immediately to ADB any grievances submitted to the GRM upon receipt. |
| ESSU | <p>Supervising Project Implementation Assistance Consultant Team for the implementation of EMP.</p> <p>Closely coordinate with other concerned agencies, local governments and communities to support implementation of EMP/CSEMP</p> <p>Ensure effective implementation of EMP components not directly tasked to the contractor including components dealing with indirect, induced and cumulative effects, as well as plans</p> |

| Organizations | Responsibilities |
|---------------|--|
| | <p>and measures for O&M phase. ESSU will review the ES related reports and submit it to PMU for approval.</p> |
| PIAC | <ul style="list-style-type: none"> • Appointing one environmental, one H&S, one social development (stakeholder engagement and labor) specialist as key team members as well as part-time technical specialists such as field Environmentalists, to ensure adequate supervision and monitoring of the contractors and capacity development. • Providing a suite of training activities for NESCO staff and contractors in relation to awareness raising on EMP implementation. • Supporting PMU in reviewing contract documents for inclusion of EMP measures before contract award, detailed designs and CSEMP/H&S Plans in accordance with the EMP requirements. • Supervising contractors for EMP implementation and preparing monthly reports to submit to PMU. • Supporting the ESSU in updating the environmental assessment, preparing inputs to quarterly progress reports, semi-annual EMRs for submission to ADB up until the completion of construction. |
| Contractor | <ul style="list-style-type: none"> • Preparation and implementation of CSEMP/H&S Plan and subplans which needs to be cleared by PMU and PIAC prior to mobilization. • Ensuring adequate budget, staff and other resources are allocated to comply with and implement the contractor's responsibilities under the EMP and to supervise and monitor the active construction site to protect the environment and ensure the health and safety of all workers and affected communities. • Recruitment of EHS core team including at least one Environmental Specialist cum pollution control expert, one Health and Safety (H&S) Specialist, one Social, Community Liaison Officer, one Labor Officer, and sufficient 24-hr EHS Supervisors/H&S Steward(s) for each active construction site and construction team of more than 50 persons to be able to undertake regular on-site supervision and monitoring activities before the commencement of works. • Implementing of all measures and responsibilities allocated to the EPC Contractor under the EMP for the full duration of the contractor's involvement including maintenance period. • Ensuring adherence to all applicable national and state environment, health, safety, and labor laws and regulations in force at the time. • Ensuring adherence to ADB's Safeguard Policy Statement (2009) and the related IFC Environment, Health and Safety (EHS) general and power transmission and distribution guidelines (2007) and the ILO safety and health in construction (2022) and ILO worker accommodation guidelines. • Whilst NESCO will obtain SCC/ECC, and tree cutting permits, the Contractor will be required to obtain any necessary outstanding permits and permissions before the commencement of related work. Copies of all clearances, permits, licenses, and insurances to be kept. • Ensuring the detailed design reflects the EMP requirements; seeking to ensure it has the same or no worse impact than the indicative designs which were assessed in the IEE. • Supporting NESCO to update (as required) the IEE in respect of the detailed design by providing sufficient details to inform a revised project description and any subsequent reassessment of impacts and risks. • Undertaking and documenting a facilitated health and safety (H&S) risk assessment considering for all phases. • Adopting a zero-tolerance approach to H&S on the project, enforce all workers to comply with the H&S requirements of the EMP including the wearing of appropriate PPE on the construction site. • Ensuring that all construction workers including all formal and informal employees and subcontractors understand their responsibilities to implement the EMP and mitigate environmental impacts and risks associated with pre-construction and construction activities. • Providing EHS training for subcontractors, formal and informal construction workers and other personnel as required. • Supporting NESCO in undertaking ongoing consultation and implementing the site-level GRM; in particular, the contractor's GRM Focal shall thoroughly document details of complaints and make its best efforts to resolve the complaints at project site level; all this information is to be included in the contractor's monthly reports to NESCO. • Undertaking environmental monitoring as set out in the Environmental Monitoring |

| Organizations | Responsibilities |
|---------------|---|
| | <p>Plan (EMoP) during pre-construction and construction and documenting both qualitative and quantitative monitoring ESSU; for quantitative monitoring the contractor is to hire surveyors and accredited, and quality assured, third-party laboratories.</p> <ul style="list-style-type: none"> • Participating in monthly meetings with the PMU, PIAC and ESSU to discuss EMP implementation progress and any EHS concerns and establishing an H&S Committee who will also meet monthly. • Submitting monthly environmental management reports to NESCO (monthly EMP reports will be stand-alone but included as part of the contractors' monthly progress reports) relating to the work undertaken over the reporting period and documenting the environmental measures including monitoring activities that have been carried out, problems encountered, record data including near misses and accidents, grievances received, and follow-up actions that were taken (or will be taken) to correct the problems. • Informing NESCO immediately in case of any approved detailed design changes or unanticipated environmental impacts occurring during implementation, and as required, provide any information needed to NESCO to enable them to promptly update the national EIA or the IEE/EMP for clearance by ADB before any changes are implemented. • Informing NESCO within 24 hours in case of chance find or accident on site and providing an incident report within 48 hours with corrective action detailing how reoccurrence will be prevented. • Inform NESCO immediately in case of any non-compliance and help them to prepare as necessary a corrective action plan for clearance by ADB. Contractors are required to implement all necessary corrective action requested by NESCO to ensure the project remains in compliance with national and state regulatory requirements, ADB's SPS 2009, the project's loan covenants and EMP requirements. |

Annex 1: Environment Management Plan

1.1 Part 1 – General Mitigation

| General Mitigation | | | | | | | | |
|---|--|--|--|--|---|-------------------|--------------------------|-------------------------|
| Project Activity | Impact or Risk | Mitigation/ Compensation/ Contingency/ Enhancement Measures | Performance Indicator | Timing | Responsibilities (implementation, supervision and monitoring) | | | Budget Source |
| | | | | | NESCO ⁸ | PIAC ⁹ | Contractor ¹⁰ | |
| Detailed Design and Pre-Construction Phase | | | | | | | | |
| Compliance with national laws and regulations and SPS 2009 requirements; all works components | Environmental and social impacts/risks of construction and O&M phase -- lack of management of detailed design, construction and O&M leading to environmental degradation, H&S risks for construction and O&M workers as well the local community | <ul style="list-style-type: none"> - NESCO and contractor to comply with national laws and regulations including those set out in the IEE in addition to international good practice e.g., IFC EHS General Guidelines (April 2007), the EHS Guidelines for Electric Power Transmission and Distribution (April 2007), the ILO guidelines on safety and health in construction and the mitigation set out within this table. - NESCO and contractor to comply with the definite version of the EMP which is the version disclosed on ADB's website. This includes any measures in an updated IEE following design or any updates in response to unanticipated impacts. Contractors will be responsible for implementing and budgeting for all measures required. - Environmental quality monitoring will be undertaken by the contractor pre construction and then regularly up to the defect liability period, except tree plantation which must be | <ul style="list-style-type: none"> - No breaches of national regulations and/or international good practice guidelines. - No breaches of EMP by NESCO, contractor, subcontractors or other third parties with prompt corrective action taken if required. - Status of EMP compliance documented in EMRs | Upon loan effectiveness for NESCO (prior to contract award in case of advance contracting or third-party works) and contract award for contractor then throughout project implementation | √ | √ | √ | NESCO and Contract Cost |

⁸ NESCO to implement EMP requirements as well as supervising and monitoring the contractor's implementation of measures delegated to them, including reviewing and approving detailed designs, CSEMPs/H&S Plans and subplans, and other documentation, reporting compliance in EMRs for submission to ADB.

⁹ PIAC to support NESCO in EMP implementation, supervision, and monitoring of the contractors, the reviewing and approving of documentation, and reporting.

¹⁰ Contractor to implement the measures delegated to them for the duration of their contract period, pre-construction measures are to be completed before the commencement of works and then to implement requirements throughout construction works reporting to NESCO monthly on the status of EMP implementation

| General Mitigation | | | | | | | | |
|--|---|---|---|--|---|-------------------|--------------------------|---------------|
| Project Activity | Impact or Risk | Mitigation/ Compensation/ Contingency/ Enhancement Measures | Performance Indicator | Timing | Responsibilities (implementation, supervision and monitoring) | | | Budget Source |
| | | | | | NESCO ⁸ | PIAC ⁹ | Contractor ¹⁰ | |
| | | <p>for 2 years post tree plantation which may be after the completion of construction works.</p> <ul style="list-style-type: none"> - If there is any conflict between the measures set out in this EMP and the national requirements, the most stringent provision is precedent. - Contractors will have in place corporate environment, health and safety policies and corporate environment, health, and safety management system certifications, such as, ISO 14001 for environment, ISO 45001 for health and safety, or equivalent. - Contractors will not engage in any activities described on the ADB Prohibited Investment Activities List in Appendix 5 of ADB's SPS (2009) | | | | | | |
| Procurement of contractors for demolition and construction work and goods supply; all works components as applicable to the scope of works | Environmental and social impacts/ risks of construction and O&M phase | <ul style="list-style-type: none"> - NESCO to ensure the EMP is incorporated in the bidding documents and the final (definitive) EMP cleared by ADB is incorporated into the contract documents for demolition and construction works prior to contract award - NESCO to ensure that the requirement to comply with the final (definitive) EMP as well as pertinent EHS requirements form an integral and binding part of the contract, including appropriate incentives and/or penalties for any non-compliance related to EHS management. - NESCO to ensure that contractors for demolition and construction have Bangladesh experience in handling hazardous waste (such as oil or PCB contaminated soil or | <ul style="list-style-type: none"> - Final EMP to be included in bidding and contract documents for demolition and construction works. - Relevant clauses in the contract document for works and goods supply contracts. - Copy of EMP related contract extracts will be attached to EMR | Prior to issue of bidding documents and contract award | √ | √ | NA | NESCO |

General Mitigation

| Project Activity | Impact or Risk | Mitigation/ Compensation/ Contingency/ Enhancement Measures | Performance Indicator | Timing | Responsibilities (implementation, supervision and monitoring) | | | Budget Source |
|--|--|---|--|--|---|-------------------|--------------------------|-------------------------|
| | | | | | NESCO ⁸ | PIAC ⁹ | Contractor ¹⁰ | |
| | | asbestos in demolished buildings if found) and aware of local guidelines for disposal of demolition and construction waste from sites. | for the period in which the contract was awarded. | | | | | |
| Detailed design and updates to IEE; all works components as applicable to the scope of works | Detailed design by contractor incorporates best practise EHS for all sites | <ul style="list-style-type: none"> - Contractors to ensure that detailed designs reflect the requirements of the IEE/EMP and international engineering best practice/good EHS practice including site-specific measures where required for protecting biodiversity and physical cultural resources and other sensitive receptors. - During detailed design contractors to ensure national seismic design requirements are followed especially for buildings and other structural foundations; building and structural designs are to be checked for seismic safety by design team. - During detailed design climate change adaptation measures identified in the Climate Risk Assessment will need to be incorporated by contractors - Contractor's detailed designs will be reviewed by NESCO's PIU with support of PIAC to confirm that all climate resilience measures required by this EMP have been adequately incorporated in them and that they reflect international engineering best practice/good EHS practice before they are approved. - Prior to the approval of detailed designs NESCO will consult ADB regarding the need to update the IEE/EMP. If required, the IEE/EMP will be updated for clearance and | <ul style="list-style-type: none"> - Detailed Design cleared and approved reflects EMP and CRA requirements. - ADB informed of any unanticipated impacts identified at any point during project implementation. - IEE updated as required to reflect detailed design and any unanticipated impacts and reviewed and cleared by ADB prior to the start of related works. | Prior to detailed design approval and for implementation during construction | √ | √ | √ | NESCO and Contract Cost |

General Mitigation

| Project Activity | Impact or Risk | Mitigation/ Compensation/ Contingency/ Enhancement Measures | Performance Indicator | Timing | Responsibilities (implementation, supervision and monitoring) | | | Budget Source |
|---|--|--|---|---|---|-------------------|--------------------------|---------------|
| | | | | | NESCO ⁸ | PIAC ⁹ | Contractor ¹⁰ | |
| | | <p>disclosure by ADB before approval of the detailed designs and the start of related works including site establishment.</p> <p>Contractor to support NESCO in respect of any update to the IEE/EMP following detailed design.</p> <ul style="list-style-type: none"> - If other changes in project scope or design occur during project implementation, or if any unanticipated impacts are identified, contractor to inform NESCO who are to immediately inform ADB of change to determine the need to update the IEE. Update will be required if NESCO or the contractor adjusts the sites that were assessed within the IEE. - Use of any asbestos containing materials is strictly prohibited – this includes all vinyl tile and all cement tile; such materials must be certified as asbestos free. - Use of PCB based oil for transformers/ transformer oil is prohibited, all transformer oil must be certified as PCB free. - Use of chlorofluorocarbons (CFCs) and halon-based substances are prohibited. | | | | | | |
| Construction EHS management planning during pre-construction and location of temporary construction facilities; all works | Preparation of CSEMP and H&S plans based upon EMP and IEE attached. Updating of these documents if required. | <ul style="list-style-type: none"> - Contractor to develop Contractor's site-specific Environmental Management Plans (CSEMPs) and H&S Plans including all subplans as required by the EMP to be approved by NESCO with support of PIAC incorporating the requirements of (i) this Environmental Mitigation Plan, (ii) the ECPs (see Annex 4), (iii) the conditions of National SCC/ECC (iv) international engineering best | <ul style="list-style-type: none"> - CSEMPs/H&S Plans and all subplans cleared and approved before work are reflective of Project EMP requirements to minimize impacts | Prior to mobilization and site establishment and for implementation during construction | √ | √ | √ | Contract cost |

General Mitigation

| Project Activity | Impact or Risk | Mitigation/ Compensation/ Contingency/ Enhancement Measures | Performance Indicator | Timing | Responsibilities (implementation, supervision and monitoring) | | | Budget Source |
|--|----------------|--|---|--------|---|-------------------|--------------------------|---------------|
| | | | | | NESCO ⁸ | PIAC ⁹ | Contractor ¹⁰ | |
| components as applicable to the scope of works | | <p>practice/good EHS practices e.g., IFC EHS guidelines including the Construction and Demolition section and ILO Safety and Health in Construction and Worker Accommodation guidelines, and (v) site-specific measures where these are required with regards to sensitive receptors in PIA or any biodiversity and physical cultural resources (if present in the area). These will be updated as required and re-approved by NESCO as during construction in case any construction methods or site conditions change, in response to an accident, incident, near miss etc.</p> <ul style="list-style-type: none"> - CSEMPs will include a biodiversity management plan with tree plantation plan, as required. Prior to their preparation the contractor will conduct pre-construction ecological surveys required to inform them (applicable to all components including existing substations) and submit the survey report. - Construction is to only be undertaken on NESCO owned land and no temporary or permanent relocation to be undertaken unless the resettlement plan is followed. - Contractor to seek to locate all temporary construction facilities required including laydown and storage areas within the boundaries of NESCO land (existing substations) except for overnight accommodation for workers that could be provided in existing properties off-site. If other public or private land is required for | and risks on EHS during subsequent stages of the project. Copies and any updates to these plans are to be attached to EMR during the period in which NESCO approved them. | | | | | |

General Mitigation

| Project Activity | Impact or Risk | Mitigation/ Compensation/ Contingency/ Enhancement Measures | Performance Indicator | Timing | Responsibilities (implementation, supervision and monitoring) | | | Budget Source |
|------------------|----------------|--|-----------------------|--------|---|-------------------|--------------------------|---------------|
| | | | | | NESCO ⁸ | PIAC ⁹ | Contractor ¹⁰ | |
| | | <p>temporary construction facilities due to lack of space within NESCO land, land use to be negotiated with private landowner, submit land ownership papers and copy of agreement for temporary land use with a photographic record of pre-project condition. Sites that are waterlogged, supporting trees or natural habitat must not be used. Drainage must be installed at all temporary facility locations to avoid waterlogging.</p> <ul style="list-style-type: none"> - Noisy and dusty facilities or those that may generate sediment laden runoff or wastewater (e.g., concrete plant, asphalt plant, refueling areas, labor camps, maintenance yards, storage areas) must be sited at least 500m from residential property (if possible) or any physical cultural resources (if any); pollution prevention equipment must be installed on such facilities. Laydown and storage areas that are not potential pollution sources may be located a minimum of 50m distance and not block accesses or road users. Contractor will not use any land requiring landfill or levelling or clearance of trees/vegetation on land for use for these areas. Photographic record of land condition to be undertaken before any works to establish temporary facilities. - Design of sanitation and welfare facilities at construction sites and labor camps/overnight accommodation to conform to IFC EHS general guidelines, ILO's guidance on worker accommodation and national regulations and | | | | | | |

General Mitigation

| Project Activity | Impact or Risk | Mitigation/ Compensation/ Contingency/ Enhancement Measures | Performance Indicator | Timing | Responsibilities (implementation, supervision and monitoring) | | | Budget Source |
|------------------|----------------|--|-----------------------|--------|---|-------------------|--------------------------|---------------|
| | | | | | NESCO ⁸ | PIAC ⁹ | Contractor ¹⁰ | |
| | | <p>to be approved by NESCO.¹² Contractors to provide all basic requirements; individual beds and beddings, individual lockers, mosquito nets, artificial lights, natural lights, windows and ventilation, fans, emergency exits, firefighting equipment, kitchen and dining halls, mobile charging points, toilets and washing facilities, potable drinking water, recreational space etc.</p> <ul style="list-style-type: none"> - Contractors will determine if they source canned drinking water from an existing commercial supplier (as the preferred option) or provide their own source of treated water for workers; all drinking water provided is to be regularly tested and confirmed to meet drinking water standards. For sources other than canned drinking water undertake baseline water quality sampling per EMoP (Annex 2) to confirm source suitability and, if necessary, provide additional water treatment facilities during construction to facilitate safe drinking water supplies. - Contractors will use locally sourced materials as far as practical to reduce transportation, but all raw materials will be sourced only from existing licensed sources e.g., sand and aggregates from quarries or borrow areas which hold SCC/ECC with submission to NESCO of all necessary documents such as | | | | | | |

¹² Indoor toilets (one per six staff) with hand washing facilities and if overnight accommodation private bathing area, showers or baths, all connected to existing sewage system or septic tank with soak away; Shaded rest area that is accessible and can accommodate the number of workers on site; Indoor food preparation and separate clean eating area, provision of sufficient fuel supply for cooking other than wood; Enclosed garbage bins for disposal of waste, as burning of waste will be prohibited, and; Potability testing before work commencement, a drinking water supply that meets drinking water standards to be provided etc.

General Mitigation

| Project Activity | Impact or Risk | Mitigation/ Compensation/ Contingency/ Enhancement Measures | Performance Indicator | Timing | Responsibilities (implementation, supervision and monitoring) | | | Budget Source |
|---|--|---|--|--|---|-------------------|--------------------------|---------------|
| | | | | | NESCO ⁸ | PIAC ⁹ | Contractor ¹⁰ | |
| | | <p>records of materials used and source with copies of SCC/ECC. Contractors will not open any borrow areas or quarries under the project, and will not undertake any river dredging for sand unless approved by NESCO and IEE/EMP has been updated.</p> <ul style="list-style-type: none"> - Contractors to provide adequate facilities for the collection, separation, and storage of construction waste (including from labor camps/overnight accommodation) on-site and safe transportation for composting or recycling or disposal through reputable, legitimate, licensed third parties with all waste transfer records retained. Leaving or disposing of construction waste by burying it on-site or disposing of it at unlicensed waste management facilities is strictly prohibited. Unsanitary open dumps are not to be used by the contractor or their third parties; for this reason, local municipal facilities must not be used by the Contractor for the disposal of waste. Reliance on municipalities is likely to result in it being open dumped due to lack of sanitary waste management facilities in Bangladesh requiring long-distance transport for disposal to be factored in. Burning of waste is also to be strictly prohibited. | | | | | | |
| Consideration of H&S thorough detailed design and construction H&S management | Preparation of H&S plans based upon EMP and IEE attached. Updating of these documents is | - Contractors to undertake facilitated H&S risk assessment with NESCO through a workshop attended by PIU and ESS Unit during the detailed design (and at other key stages) so it can inform both the detailed design and pre-construction preparations, | CSEMPs/H&S Plans and all subplans cleared and approved before work are reflective of EMP | Prior to mobilization and site establishment and for implementation during | √ | √ | √ | Contract cost |

General Mitigation

| Project Activity | Impact or Risk | Mitigation/ Compensation/ Contingency/ Enhancement Measures | Performance Indicator | Timing | Responsibilities (implementation, supervision and monitoring) | | | Budget Source |
|--|---|---|--|--------------|---|-------------------|--------------------------|---------------|
| | | | | | NESCO ⁸ | PIAC ⁹ | Contractor ¹⁰ | |
| planning during pre-construction; all works components as applicable to the scope of works | required to mitigate any additional occupational H&S risks. | <p>considering both occupational and community H&S risks resulting from subsequent stages of the project. Facilitated workshop will involve the design and construction team of the contractors and NESCO O&M staff. For works in existing substations of PGCB their O&M staff will also be invited to participate in the workshop.</p> <ul style="list-style-type: none"> - Informed by the outcome contractors to develop a H&S Plan to avoid, minimize and mitigate occupational H&S risks. NESCO will be required to approve the H&S Plan and then ensure their own staff on-site follow it when on site. - Contractors will set up an accident reporting system for any health and safety incidents (near miss, minor, lost time, fatal) involving workers or community to be reported to NESCO within 24 hours of occurrence with a response plan detailing the incident and how its reoccurrence will be avoided. NESCO must report any lost time or fatal incidents to ADB within 48 hours containing record of incident and response taken should include date, time, details of incident, treatment given and outcome, and lessons learnt for the future. Contractors will ensure all workers are covered by medical/accident insurance to pay out in the event of a disability or fatality. Contractor's insurance includes a community liability clause for payment of compensation in case of any accidents because of construction. | requirements to minimize impacts and risks on EHS during subsequent stages of the project. Copies and any updates to be attached to EMR during the period in which they are approved by NESCO. | construction | | | | |

General Mitigation

| Project Activity | Impact or Risk | Mitigation/ Compensation/ Contingency/ Enhancement Measures | Performance Indicator | Timing | Responsibilities (implementation, supervision and monitoring) | | | Budget Source |
|--|---|--|--|---|---|-------------------|--------------------------|-------------------------|
| | | | | | NESCO ⁸ | PIAC ⁹ | Contractor ¹⁰ | |
| | | <ul style="list-style-type: none"> - Emergency contact number and details for medical, fire, etc. are to be displayed in all construction sites. | | | | | | |
| Environmental safeguards staffing and employment of construction workers; environment safeguards training and awareness raising activities; all works components as applicable to the scope of works | Environmental and social impacts of construction phase -- lack of EHS management capabilities on NESCO and Contractor's part, leading to environmental degradation, H&S risks for construction workers as well the local community. | <ul style="list-style-type: none"> - NESCO to populate and assign to PIU staff from the ESS Unit as set out in the EMP institutional arrangements. - The ESS Unit staff will be delegated authority under the contract to be able to halt construction works if any EHS issues arise. - The ESS Unit staff with input of their team and PIAC experts will be responsible for approval of CSEMP etc. - Contractors to recruit EHS team, they will employ staff as set out the EMP institutional arrangements including enough H&S supervisors for overseeing each active site and work shift as set out in the EMP institutional arrangements for onsite supervision and monitoring of environment safeguards implementation daily for the duration of works. - Subcontractors to be required to appoint an EHS representative for each construction site. - CVs of the contractors EHS team plus team structure to be submitted to NESCO in bid document or immediately on contract award for approval before mobilization. List of staff and copies of CVs to be reflected in the first monthly progress report. Any updates to be reflected in the succeeding progress reports. - Maintain administrative procedures for recruitment. No illegal forced or child labor to | <ul style="list-style-type: none"> - ESS Wing established with suitably qualified staff with PIU supported by ESS Wing and PIAC. - Contractor equipped with approved EHS team prior to mobilization. - EHS staffing details for period to be included in EMR. - No breach of Bangladesh labor laws and labor management sub-plan under the CSEMPs. - Breakdown of construction worker profiles, plus verifiable proof of age and wage documentation for every worker, | Upon loan effectiveness for NESCO (prior to contract award in case of advance contracting) and contract award for contractor and then throughout project implementation | √ | √ | √ | NESCO and contract cost |

General Mitigation

| Project Activity | Impact or Risk | Mitigation/ Compensation/ Contingency/ Enhancement Measures | Performance Indicator | Timing | Responsibilities (implementation, supervision and monitoring) | | | Budget Source |
|------------------|----------------|--|---|--------|---|-------------------|--------------------------|---------------|
| | | | | | NESCO ⁸ | PIAC ⁹ | Contractor ¹⁰ | |
| | | <p>be employed in construction with the minimum age for employment on the construction site to be 18 given hazardous nature of works involved – no persons under 18 to be employed. Working hours to be in accordance with Bangladesh labor laws to minimize H&S risks.</p> <ul style="list-style-type: none"> - Contractors must not discriminate and must proactively encourage the employment of suitably skilled women on the project. - Contractors must proactively encourage local employment for unskilled roles whilst ensuring suitably qualified and experienced workers for skilled roles; local labor can be used for manual and office work, but precedence must be given to ensuring that all workers are appropriately skilled given the hazardous nature of construction works. Contractors are to provide construction skill enhancement training to local communities to enhance the skill of local people and help avoid conflict, if skilled workers not locally available. - Contractors to ensure the provision medical/accident insurance for all staff and workers (formal and informal) for the duration of their contracts and 14 days sick leave for all construction workers. - NESCO to prepare a detailed training plan elaborating how training and awareness raising activities required by EMP will be | <p>insurance certificates and labor related permissions are maintained by the contractor throughout the project.</p> <ul style="list-style-type: none"> - No incidents/ community complaints related to impacts from influx of workers. - Detailed training plan reflecting EMP requirements developed. - Records of all training activities are retained. Training undertaken will be documented and reported in EMRs including photos and records of participants (including gender breakdown) | | | | | |



General Mitigation

| Project Activity | Impact or Risk | Mitigation/ Compensation/ Contingency/ Enhancement Measures | Performance Indicator | Timing | Responsibilities (implementation, supervision and monitoring) | | | Budget Source |
|------------------|----------------|---|--|--------|---|-------------------|--------------------------|---------------|
| | | | | | NESCO ⁸ | PIAC ⁹ | Contractor ¹⁰ | |
| | | <p>conducted and with the support of PIAC conduct required training sessions on EMP implementation and GRM operationalization for all those with management responsibilities to clarify requirements, roles and responsibilities, record keeping and reporting at each stage of the project. Contractor to ensure all members of contractor's EHS team, design team, and construction management team attend trainings.</p> <ul style="list-style-type: none"> - Contractor to prepare a detailed training plan upon contract award elaborating how training and awareness raising activities required by EMP will be conducted. - Prior to the start of and then throughout construction contractor to conduct training for construction management and provide all workers and visitors onsite, irrespective of them being formally or informally employed by contractor, subcontractor or third-party with an EHS induction before being allowed on-site including dos and don'ts in relation to construction site, temporary workers camps, local communities, forests, protected areas, etc. Contractor to ensure training and induction to each of the workers will include but not be limited to good housekeeping at all times; environmentally sound waste management practices; hygiene and communicable disease prevention including STD and HIV/AIDs; sexual exploitation, abuse and harassment prevention; culturally acceptable practices. - Contractor to prepare with guidance of health | <ul style="list-style-type: none"> - Trainings and awareness raising delivered in accordance with the training plan. - Contractors and construction workers fully aware of their responsibilities under the EMP through training | | | | | |

General Mitigation

| Project Activity | Impact or Risk | Mitigation/ Compensation/ Contingency/ Enhancement Measures | Performance Indicator | Timing | Responsibilities (implementation, supervision and monitoring) | | | Budget Source |
|--|---|--|--|--|---|-------------------|--------------------------|-------------------------|
| | | | | | NESCO ⁸ | PIAC ⁹ | Contractor ¹⁰ | |
| | | <p>experts communicable information video/brochures/leaflets for distribution to all workers during induction, covering factual health issues as well as behaviour change issues (e.g., good hygiene) around the transmission infection vector borne and viral communicable diseases including STDs and HIV/AIDS.</p> <ul style="list-style-type: none"> - Contractor to prepare with guidance of labor experts a worker Code of Conduct and information video/brochure/leaflet for distribution to all workers during induction addressing culturally acceptable practices etc. | | | | | | |
| Establishment of a functioning Grievance Redress Mechanism; all works components | Unresolved community grievances and increased conflict due to lack of operational Grievance Redress Mechanism (GRM) | <ul style="list-style-type: none"> - NESCO to set up and operationalize a three layer GRM for local community and workers as set out in the IEE, identifying GRM focals and GRC and ensuring all the members are trained on the process. - Contractor's EHS team to operationalize the informal site level GRM per the IEE, and support NESCO in resolving and addressing grievances entering the formal GRM, keep record of all grievances registered, status, time taken for redressal and outcomes, etc. Nominate a GRM Focal Point for each construction site who will keep affected persons and local communities informed of the status of work and be readily available onsite to receive, document and deal with grievances at site level. - NESCO and contractor to ensure GRM as well as the GRM process and means to | <ul style="list-style-type: none"> - GRM as per IEE operationalized, affected persons aware of its existence and are actively using GRM to raise their grievances. - 100% of grievances received are recorded and resolved in a timely manner as per GRM process; no unresolved grievances. - Records to be | Upon loan effectiveness for NESCO (prior to contract award in case of advance contracting) and contract award for contractor | √ | √ | √ | NESCO and contract cost |

General Mitigation

| Project Activity | Impact or Risk | Mitigation/ Compensation/ Contingency/ Enhancement Measures | Performance Indicator | Timing | Responsibilities (implementation, supervision and monitoring) | | | Budget Source |
|------------------|----------------|--|---|--------|---|-------------------|--------------------------|---------------|
| | | | | | NESCO ⁸ | PIAC ⁹ | Contractor ¹⁰ | |
| | | <p>submit a grievance is communicated verbally to the community especially those within 500m of 9no. existing SS before commencement of works. Information on GRM to be disseminated through community meetings, one-on-one consultations, posters, leaflets, brochures, SMS, or sign boards in prominent areas. Contractor to provide notice boards at all substations, construction site offices and active work sites including highly visible details of the GRM including the name, designation, contact numbers including phone/SMS/What's App, address of both the NESCO and contractor's GRM focal persons plus the timeline and process of redressal together with a suggestion box that is regularly checked for any grievances received.</p> <ul style="list-style-type: none"> - Contractor shall establish a telephone hotline for grievances staffed at all times during working hours. Contact details shall be prominently displayed at the sites as above. - GRM will be available to all workers for receiving and handling complaints about unfair treatment or unsafe living or working conditions, ensuring no coercion nor reprisal. Construction workers will be given access to register any grievances with the contractors or direct access to the NESCO GRM Focal. - Contractor to carry out awareness raising among workers on the GRM at the start of employment onsite, including details on how to submit a grievance, process, and timeframes including disseminating GRM | <p>kept of all grievances received and their resolution for reporting per the IEE.</p> <ul style="list-style-type: none"> - Details of GRM being operation, including photos of awareness raising activities to be submitted in EMR. - Details of all grievances received and resolved during the period to be reported in EMR. | | | | | |

| General Mitigation | | | | | | | | |
|---|---|---|--|---|---|-------------------|--------------------------|-------------------------|
| Project Activity | Impact or Risk | Mitigation/ Compensation/ Contingency/ Enhancement Measures | Performance Indicator | Timing | Responsibilities (implementation, supervision and monitoring) | | | Budget Source |
| | | | | | NESCO ⁸ | PIAC ⁹ | Contractor ¹⁰ | |
| | | <p>contact details on noticeboards and placing suggestion boxes at construction site offices and at employer provided staff accommodation.</p> <ul style="list-style-type: none"> - NESCO and contractor to encourage affected persons to use the GRM but also clarify that the GRM can run in parallel with legal redress. NESCO and Contractor to inform about the option to raise a grievance with ADB's resident mission and then ADB's Accountability Mechanism as the last resort. | | | | | | |
| Meaningful consultations, information disclosure and community awareness raising activities; all works components as applicable to the scope of works | Unresolved community grievances regarding disruption and disturbance and increased conflict due to lack of communication with the local community regarding project impacts and risks | <ul style="list-style-type: none"> - NESCO to prepare a detailed stakeholder engagement plan for dissemination with the local community especially those in the vicinity before commencement of works. - No work will start on site until NESCO has locally disclosed the IEE on their website with executive summary translated into Bangla and placed hard copies at construction site offices. Copies of the executive summary in Bangla will be printed and disseminated through community meetings, one-on-one consultations, or sign boards in prominent areas. Hard copies and translation to Bangla of the full IEE/EMP are to be provided by NESCO upon request by affected persons. If an IEE update is required, it will be similarly disclosed as will findings of EMRs. - Contractor to consult with and seek agreement of landowners and local communities within 500m of proposed locations for any temporary labor camps, site offices, storage areas, areas for waste | <ul style="list-style-type: none"> - Stakeholder engagement plan prepared, and IEE is locally disclosed and accessible to affected persons. - Details of all consultations and awareness raising activities undertaken by NESCO and contractor documented and reported in EMRs including photos and records of participants (including gender breakdown). - Local | Upon loan effectiveness for NESCO (prior to contract award in case of advance contracting) and contract award for contractor and then throughout project implementation | √ | √ | √ | NESCO and contract cost |

General Mitigation

| Project Activity | Impact or Risk | Mitigation/ Compensation/ Contingency/ Enhancement Measures | Performance Indicator | Timing | Responsibilities (implementation, supervision and monitoring) | | | Budget Source |
|------------------|----------------|---|---|--------|---|-------------------|--------------------------|---------------|
| | | | | | NESCO ⁸ | PIAC ⁹ | Contractor ¹⁰ | |
| | | <p>management, etc. They will need to seek agreement of local communities to temporarily use any community resources (e.g., water supplies) during construction to identify any potential conflict.</p> <ul style="list-style-type: none"> - Contractor to consult with local communities and other concerned stakeholders including local government officials and public utilities as well as the local police and municipalities during design in order that any concerns raised can be reflected in site layouts and construction methods, contractor to continue liaising in construction. - Contractor to communicate at least four weeks (one month) prior to the commencement of works through community meetings, one-on-one consultations, posters, leaflets, brochures, SMS, or sign boards in prominent areas about the agreed schedule of and details of the planned construction works including its anticipated impacts, such as traffic disruption (road closures, diversions, including notices/signs on either end and marking of the diversion routes) to help manage any disruption and disturbance to and potential conflicts with local communities. Contractor will specifically notify the local community about the commencement of works and any high dust or noise activities (especially demolition, earthwork and piling work) and any activities that might pose safety risks to the community - Contractor to continue with consultations with affected persons who will be most impacted | <p>communities and other concerned stakeholders kept informed throughout project implementation, and aware of construction, providing with awareness raising etc.</p> | | | | | |

General Mitigation

| Project Activity | Impact or Risk | Mitigation/ Compensation/ Contingency/ Enhancement Measures | Performance Indicator | Timing | Responsibilities (implementation, supervision and monitoring) | | | Budget Source |
|------------------|----------------|--|-----------------------|--------|---|-------------------|--------------------------|---------------|
| | | | | | NESCO ⁸ | PIAC ⁹ | Contractor ¹⁰ | |
| | | <p>(in 500m of 9no. existing SS components) on at least a weekly basis to keep them fully informed of the nature of works, construction progress and the forthcoming schedule. They will be specifically notified about the commencement of works and any high dust or noise activities (especially demolition, earthwork and piling work) and any activities that might pose safety risks to the community</p> <ul style="list-style-type: none"> - Contractor to undertake construction safety community awareness raising activities in affected communities in 500m of 9no. existing SS components, especially with schools, on community awareness about construction of the project and about construction safety and electrical safety including accidents, electrocution risks, etc. - Contractor to undertake electrical safety community awareness raising activities in local affected communities within 500m of 9no. existing SS components, and especially with schools, awareness raising activities to be repeated on completion of construction; to include electrocution risks, EMF, etc. The awareness sessions should provide information regarding the findings of the IEE on EMF and specifically discuss best practice reference limits for EMF and how they have been applied to the Project. - Community awareness by NESCO will use distribution of posters, leaflets, and safety booklets to all households in Bangla within 500m in addition to face to face awareness raising by the contractor. These posters and | | | | | | |

General Mitigation

| Project Activity | Impact or Risk | Mitigation/ Compensation/ Contingency/ Enhancement Measures | Performance Indicator | Timing | Responsibilities (implementation, supervision and monitoring) | | | Budget Source |
|--|--|---|--|-------------------------|---|-------------------|--------------------------|-------------------------|
| | | | | | NESCO ⁸ | PIAC ⁹ | Contractor ¹⁰ | |
| | | safety booklets will also be available to pick up within substations, local NESCO offices etc. - Contractors to distribute leaflets/pamphlets/posters to the local community covering (i) health awareness including HIV/AIDS/STDs and other vector borne and viral communicable diseases, and (ii) the conduct of construction workers that can be expected. | | | | | | |
| Construction Phase | | | | | | | | |
| Onsite construction activities in general including works for temporary facilities; all works components as applicable to the scope of works | Environmental and social impacts of construction phase -- lack of management of construction leading to environmental degradation, H&S risks for construction workers as well the local community. | - Contractor to comply with EMP including ECP and EMOP and the approved CSEMP/H&S Plans including all subplans along with the IFC EHS Guidelines and ILO Safety and Health in Construction Guidelines and worker accommodation guidelines during construction. - NESCO to undertake at least weekly checks of EHS activities on active construction sites ensuring at least monthly supervision visits as well as periodic "spot check" site visits to all contract packages whilst directing supervision efforts towards the most environmentally sensitive components of the project. - Contractor to ensure each active construction site has an EHS Supervisor on site full time with responsibility for ensuring EMP implementation on their site per institutional arrangements. - Contractor's EHS team will oversee EMP implementation and provide guidance on | - No breaches of national regulations and/or international good practice guidelines. - No breaches of EMP by NESCO, contractor, subcontractors or other third parties with prompt corrective action taken if required - Compliance with EMP documented in Contractor's monthly progress reports - Status of EMP | Throughout construction | √ | √ | √ | NESCO and contract cost |

General Mitigation

| Project Activity | Impact or Risk | Mitigation/ Compensation/ Contingency/ Enhancement Measures | Performance Indicator | Timing | Responsibilities (implementation, supervision and monitoring) | | | Budget Source |
|------------------|----------------|--|-------------------------------|--------|---|-------------------|--------------------------|---------------|
| | | | | | NESCO ⁸ | PIAC ⁹ | Contractor ¹⁰ | |
| | | <p>corrective actions. The contractor through the EHS team will document activities and compliance with EHS and conditions onsite through photos and written records.</p> <ul style="list-style-type: none"> - The contractor will comply with any corrective action plan required and cover the costs where corrective action is required due to noncompliance on behalf of the contractor, its subcontractors or third parties. - Contractors will ensure all their subcontractors and third parties, irrespective of being formally or informally employed by them, also comply with the EMP and any updates to it, as well as the contractor's approved CSEMP/H&S Plans and other subplans. Provisions will be incorporated into all sub-contracts to ensure compliance with the Contractor's CSEMP/H&S Plans and all other plans at all tiers; all will be given a copy of the IEE/EMP and CSEMP/H&S Plan and all other subplans. - Contractors will put in place appropriate incentives and/or penalties for compliance/non-compliance by subcontractors and workers related to the use of PPE, prohibition on firewood etc. - Land filling activities should receive increased environmental supervision from the contractor and NESCO to ensure environmentally sound construction methods are being used at all times especially if subcontractors are used. - Piling activities should also receive increased EHS supervision attention from the contractor | compliance documented in EMRs | | | | | |

General Mitigation

| Project Activity | Impact or Risk | Mitigation/ Compensation/ Contingency/ Enhancement Measures | Performance Indicator | Timing | Responsibilities (implementation, supervision and monitoring) | | | Budget Source |
|--|---|---|--|---|---|-------------------|--------------------------|---------------|
| | | | | | NESCO ⁸ | PIAC ⁹ | Contractor ¹⁰ | |
| | | and NESCO to ensure safe and environmentally sound construction methods are being used at all times especially if subcontractors are used. <ul style="list-style-type: none"> - All equipment and machinery used during construction to be of modern design, maintained in good condition, and with secure and strong health and safety guards installed around moving parts and kept in use at all times. - Fuel, oils and lubricants for operating equipment and machinery must be kept on the drip trays whilst in use on site. - Stack emissions of any temporary diesel generator set or hot mix to comply with national emission standards with the stack height design according to both GoB requirements and international good industry practice (as per IFC EHS General Guidelines). | | | | | | |
| Environment safeguards training and awareness raising activities; all works components | Environmental and social impacts of construction phase - lack of EHS management capabilities on NESCO and Contractor's part, leading to environmental degradation, H&S risks for construction | <ul style="list-style-type: none"> - Contractors to ensure workers with a specific role have, before been allocated the task, attended specialized health and safety trainings related that role e.g., health and safety stewards, first aiders, fire safety officers, as well as ensuring workers have received task-specific trainings for working at height, demolition, working with electricity, etc. - Only allow suitably trained and qualified workers to work on electrical equipment and at height, these workers must have a training record of attending suitable training course | <ul style="list-style-type: none"> - Contractors and construction workers fully aware of their responsibilities under the EMP through training. - Records of all training activities are retained. - Training undertaken will be documented | Throughout construction at least weekly basis | √ | √ | √ | Contract cost |

General Mitigation

| Project Activity | Impact or Risk | Mitigation/ Compensation/ Contingency/ Enhancement Measures | Performance Indicator | Timing | Responsibilities (implementation, supervision and monitoring) | | | Budget Source |
|------------------|-------------------------------------|--|--|--------|---|-------------------|--------------------------|---------------|
| | | | | | NESCO ⁸ | PIAC ⁹ | Contractor ¹⁰ | |
| | workers as well the local community | <p>on electrical safety and working at height and be provided with and wear the appropriate PPE for their role. Untrained workers must not be permitted to work with either live electricity or at height.</p> <ul style="list-style-type: none"> - During construction site and activity specific risk assessments to be undertaken prior to the commencement of related work to identify the hazards present and applicable measures to be followed. - Contractors to undertake regular, compulsory awareness raising activities for all workers related to the EMP, including short monthly EHS refresher sessions, daily toolbox talks and posting of information at construction site offices, labor camps, and all work sites etc. - Contractors to conduct regular emergency preparedness and response drills involving all workers irrespective of them being formally or informally employed by contractor, subcontractor or third-party to prepare them in case of an environmental or health and safety incident including fire, spillage, natural disaster, disease outbreak, etc. - Emergency preparedness and response training for construction management will include modules on first aid and fire safety including training on how to use first aid and firefighting equipment provided on-site. - All construction workers to be made aware of the chance-find procedure and types of finds to be reported. - Driver training to include advice on behavior to reduce the potential for disturbance, | and reported in EMRs including photos and records of participants (including gender breakdown) | | | | | |

Qin

Dr.

| General Mitigation | | | | | | | | |
|--|---|--|--|-------------------------|---|-------------------|--------------------------|---------------|
| Project Activity | Impact or Risk | Mitigation/ Compensation/ Contingency/ Enhancement Measures | Performance Indicator | Timing | Responsibilities (implementation, supervision and monitoring) | | | Budget Source |
| | | | | | NESCO ⁸ | PIAC ⁹ | Contractor ¹⁰ | |
| | | including use of horn, loud radios with windows open, switching engines off when not in use, strictly observing speed limits and not accelerating or braking aggressively. | | | | | | |
| Construction workers; all works components | Upholding of the labour rights of construction workers to maintain H&S | <ul style="list-style-type: none"> - Contractor to ensure that national labor law and ILO core labor standards are upheld. All workers receive at least the minimum wage as defined by national legislation and additional work hours are adequately compensated. Workers operate within legal working hours; overtime hours must be voluntary and workers must not undertake more than 60 hours per week per GOB law. | No breach of Bangladesh labor law or labor management sub-plan under the CSEMPs. | Throughout construction | √ | √ | √ | Contract cost |
| Site clearance and earthworks including works for temporary facilities; all works components except internal fit out | Impacts to soil and vegetation cover, loss of biodiversity habitat and disturbance to flora and fauna | <ul style="list-style-type: none"> - Ensure clear demarcation of the working area and avoid encroachment outside the agreed impact area. Implement careful construction practices to avoid damage to trees. Vehicle movements to be restricted to demarcated working areas to reduce unnecessary impacts to adjacent land. - Demarcation of trees to be avoided and retained as per tree plantation plan approved by NESCO. - Only marked trees are to be cut or trimmed after joint verification with PIU and approval of tree list. In case tree cutting is required, NESCO to secure the necessary permit from the Forest Department and contractors to schedule tree cutting/trimming outside the bird breeding season with all trees checked by an Environmentalist for nesting birds and other fauna prior to being cut. Similarly, any burrows will be checked for fauna by an | <ul style="list-style-type: none"> - EMP/CSEMP requirements successfully implemented as determined through regular site checks, photographic record etc. - No outstanding grievances related to impacts on biodiversity etc. | Throughout construction | √ | √ | √ | Contract cost |

General Mitigation

| Project Activity | Impact or Risk | Mitigation/ Compensation/ Contingency/ Enhancement Measures | Performance Indicator | Timing | Responsibilities (implementation, supervision and monitoring) | | | Budget Source |
|------------------|----------------|--|-----------------------|--------|---|-------------------|--------------------------|---------------|
| | | | | | NESCO ⁸ | PIAC ⁹ | Contractor ¹⁰ | |
| | | <p>Environmentalist before any earthworks commence.</p> <ul style="list-style-type: none"> - Record all trees removed during construction, compensation paid, and replacements at 1:3 planted in accordance with the Tree Plantation Plan and monitor their current health and survival status, trees to be planted as early as possible but latest before commissioning to ensure maintenance for 1.5 years following plantation. - Use of herbicides or burning to clear vegetation is strictly prohibited. Cut/trimmed trees and other vegetation trimmings will be immediately removed from the site. No dumping of cut vegetation onto agricultural fields. - Minimize removal of existing vegetation and topsoil. Excavated spoil to be reused as a landscaping material. Topsoil disturbed will be separately stored and used to restore exposed surfaces which will be promptly revegetated with native species including areas used for temporary construction facilities. If topsoil is stored for more than six months, the stacks will be monitored for anaerobic conditions and manual aeration will be undertaken if they develop. Topsoil storage areas will be protected from vehicle movements to avoid soil compaction. - Carry out works during the dry season outside the urban area to minimize soil erosion and sedimentation and in wet conditions, minimize the use of heavy machinery. Consideration of the temporary | | | | | | |

General Mitigation

| Project Activity | Impact or Risk | Mitigation/ Compensation/ Contingency/ Enhancement Measures | Performance Indicator | Timing | Responsibilities (implementation, supervision and monitoring) | | | Budget Source |
|------------------------|---------------------------------|---|--------------------------|-------------------------|---|-------------------|--------------------------|---------------|
| | | | | | NESCO ⁸ | PIAC ⁹ | Contractor ¹⁰ | |
| | | use of removable steel plates to protect soil and its vegetation cover. - Construction lighting to be directional avoiding spill outside the working area at all construction sites and noise attenuating screens to be erected to avoid disturbance to residents and wildlife in areas flagged in the IEE. - Strict prohibition of cutting of fuelwood or timber for cooking by the construction workers. Contractor to provide alternative fuel source (e.g., kerosene/LPG) which will be stored safely. - Trainings will be provided to workers on identification of threatened species, dos and don'ts in relation to disturbance to local birds, prohibition on illegal activities including poaching, and regarding chance encounter with wild animals (especially those species that can be dangerous to human like snakes, etc.) at site or in the labor camp and wildlife rescue protocols; contacts for any wildlife rescue will be displayed in the construction office and labor camp - Construction activities to be scheduled to avoid high rainfall periods when drainage may become congested and result in flood, drainage connectivity and the natural flow of waterbodies must not be obstructed or diverted to another direction. | | | | | | |
| Transportation, use of | Impacts due to dust and vehicle | - Construction equipment and vehicles to meet national emission standards including for air | - EMP/CSEMP requirements | Throughout construction | √ | √ | √ | Contract cost |

General Mitigation

| Project Activity | Impact or Risk | Mitigation/ Compensation/ Contingency/ Enhancement Measures | Performance Indicator | Timing | Responsibilities (implementation, supervision and monitoring) | | | Budget Source |
|--|---|--|---|--------|---|-------------------|--------------------------|---------------|
| | | | | | NESCO ⁸ | PIAC ⁹ | Contractor ¹⁰ | |
| construction plant, demolition and earthworks including works for temporary facilities; all works components | emissions on air quality Impacts due to construction noise | and noise. – Avoid the use of diesel- or petrol-powered and use mains electricity or battery-powered equipment where practicable. – Belching of black smoke prohibited, use diesel fuel that has a low sulfur content, less than 0.1%. – Use low noise generating equipment e.g., less than 55dBA sound pressure level at 1m. – The use of horns in areas where sensitive receptors are located (houses, schools, clinics, mosques, etc.) will be prohibited. – Regularly check and maintain construction equipment and vehicles to keep them in good working condition as per the manufacturer’s specifications to meet emission standards. Record all maintenance works undertaken. – Vehicles shall not be left running idle for more than 5 minutes. – Regular sprinkling of water to be undertaken for dust suppression at the construction site (excavations, earthen or otherwise dusty access roads, and material stockpiles). (i.e. 3 times per day but more often if needed during traffic movements, earthwork, dry or windy conditions) but avoid overwatering as it can make for muddy conditions. – CSEMP will include a provision for a daily log-sheet to record dust suppression activities, which will be shared with NESCO for inclusion in EMR. – Stockpiles of spoils and other dust generating materials to be kept to a minimum. Cover stockpiles with tarpaulin. Locate stockpiles as | successfully implemented as determined through regular site checks, photographic record etc. – No exceedance of air quality or noise levels (Annex 3) or increase in baseline air or noise pollution levels where they are already exceeded. – No outstanding grievances related to impacts from dust, air and noise pollution. | | | | | |

General Mitigation

| Project Activity | Impact or Risk | Mitigation/ Compensation/ Contingency/ Enhancement Measures | Performance Indicator | Timing | Responsibilities (implementation, supervision and monitoring) | | | Budget Source |
|------------------|----------------|---|-----------------------|--------|---|-------------------|--------------------------|---------------|
| | | | | | NESCO ⁸ | PIAC ⁹ | Contractor ¹⁰ | |
| | | <p>far away as possible from residential property to avoid inconvenience from fugitive dust and from waterbodies to minimize pollution. Ensure they are enclosed by a solid fence or equivalent to avoid windblown dust and sediment laden runoff entering waterbodies. Minimize double handling and drop loads.</p> <ul style="list-style-type: none"> - Remove materials that have the potential to produce dust from site as soon as possible, unless being re-used on site. If they are being re-used on-site cover, seed or fence stockpiles to prevent wind whipping. - Trucks transporting any loose materials or loose spoil from construction sites to local approved disposal sites will be covered with tarpaulin to reduce dust. - Position any stationary emission sources (e.g. diesel generators, compressors, etc.) as far as practical from sensitive receptors (houses, schools, clinics, mosques, etc.) - Construction lighting to be directional avoiding spill outside the working area at all construction sites and noise attenuating screens to be erected to avoid disturbance to residents and wildlife in areas flagged in the IEE. - Only use cutting, grinding, or sawing equipment fitted or in conjunction with suitable dust suppression techniques such as water sprays or local extraction, e.g., suitable local exhaust ventilation systems. - Impose speed limits on construction vehicles to minimize exhaust and dust emissions along areas where sensitive receptors are | | | | | | |

Om

Dr.

General Mitigation

| Project Activity | Impact or Risk | Mitigation/ Compensation/ Contingency/ Enhancement Measures | Performance Indicator | Timing | Responsibilities (implementation, supervision and monitoring) | | | Budget Source |
|--|--|---|---|-------------------------|---|-------------------|--------------------------|---------------|
| | | | | | NESCO ⁸ | PIAC ⁹ | Contractor ¹⁰ | |
| | | located (houses, schools, clinics, mosques, etc.) – 10km/hr on site and 30km/hr on unpaved roads otherwise per the national limits. – Clean dust from access roads daily and then once after all construction work is completed. – Strictly prohibit the burning of waste generated by project-related activities. – Ensure workers working near or having long exposure to vehicle exhausts and earthworks are provided with clean N95 dust masks to avoid inhalation or particulate matter and other pollutants. | | | | | | |
| Use of materials in construction works including works for temporary facilities especially fuel, oil and chemicals; all works components | Generation of construction wastes and use of hazardous materials | – In locations where waste is dumped (existing site conditions) the contractor will clean the site and collect the waste for onward disposal before they commence their works. – Contractor to provide adequate facilities for handling and storage of construction materials to reduce the amount of waste that is caused by damage or exposure to the elements and a system for the collection/storage of wastes generated. Provide a central covered area for storage of construction materials etc. Only volumes of material required for the day's work will be stored on-site. – Fuel, oil, and chemicals used to be kept under lock and key and stored in labelled, sealed containers on drip trays to provide secondary containment. Waste oil to be stored in drums and similarly stored. In designated storage areas, these will be | – No deterioration in soil and water quality from baseline levels – EMP/CSEMP requirements successfully implemented as determined through regular site checks, photographic record etc. – No outstanding pollution or waste related grievances from local communities or other interested | Throughout construction | √ | √ | √ | Contract cost |

General Mitigation

| Project Activity | Impact or Risk | Mitigation/ Compensation/ Contingency/ Enhancement Measures | Performance Indicator | Timing | Responsibilities (implementation, supervision and monitoring) | | | Budget Source |
|------------------|----------------|--|-----------------------|--------|---|-------------------|--------------------------|---------------|
| | | | | | NESCO ⁸ | PIAC ⁹ | Contractor ¹⁰ | |
| | | located on an impermeable 110% bunded surface and be under cover. - Mount construction plant and equipment containing oil and diesel on drip trays to catch leaks – all diesel operated equipment to have self-contained fuel tank. - Provide spill prevention kits (sorberent pads, loose sorberent material, etc.) at storage areas and other at-risk locations within clearly labelled containers to immediately confine any spills or leaks that occur. - Provision of designated hard standing areas for equipment servicing, refueling and wash down at least 50m from surface water and groundwater wells, with drainage directed through oil and grease interceptors before being discharged into a settling pond prior to discharge offsite. - No wastewater will be discharged direct to surface waterbodies or groundwater without adequate treatment. Use of pit latrines is prohibited as is open defecation and urination. Provision of adequate on-site sanitation facilities including connection to septic tanks with soak-aways or alternative temporary sanitary facilities that do not allow untreated disposal of sewage to adjacent water bodies e.g., portable toilets where the wastewater generated is enclosed in a container and will later be taken offsite for wastewater treatment and disposal. - Request suppliers to minimize packaging of goods - Minimize waste generation, restrict use of | stakeholders | | | | | |

General Mitigation

| Project Activity | Impact or Risk | Mitigation/ Compensation/ Contingency/ Enhancement Measures | Performance Indicator | Timing | Responsibilities (implementation, supervision and monitoring) | | | Budget Source |
|------------------|----------------|--|-----------------------|--------|---|-------------------|--------------------------|---------------|
| | | | | | NESCO ⁸ | PIAC ⁹ | Contractor ¹⁰ | |
| | | <p>plastics and polyethene and use recyclable/biodegradable materials during construction to the extent possible. Ensure that the waste hierarchy is followed including prevention, minimization, reuse and recycling -- maximum reuse and recycling of waste.</p> <ul style="list-style-type: none"> - Any plant or equipment that is rejected during the installation and commissioning due to damage or failure to immediately be removed from the site and returned to the supplier. - Constructions wastes, rejects, parts, etc. are not to be dumped outside existing substation boundaries or in drains/khals/beels/rivers or any agricultural land but stored for disposal in a temporary designated storage area within the construction site. - It must be ensured that spoil reused on site is not contaminated with solid and hazardous waste (including oil spills) by maintaining good housekeeping and waste segregation/storage/transport/disposal. If spoil is contaminated it will need to be taken off site by a licensed waste management operator for disposal at a licensed waste management facility suitable for accepting hazardous waste. - Records of excavated spoil, generated waste, and transfer records will be kept by the contractors. Contractors will keep copies of the waste management company's licenses on file at the site office. Document all volumes and types of wastes generated and removed off site (inert, solid, hazardous) using transfer notes, to be taken by licensed | | | | | | |

Om

Dr.

General Mitigation

| Project Activity | Impact or Risk | Mitigation/ Compensation/ Contingency/ Enhancement Measures | Performance Indicator | Timing | Responsibilities (implementation, supervision and monitoring) | | | Budget Source |
|--|--|---|---|-------------------------|---|-------------------|--------------------------|---------------|
| | | | | | NESCO ⁸ | PIAC ⁹ | Contractor ¹⁰ | |
| | | <p>waste contractors who should reuse/recycle or dispose of the waste according to type to suitably licensed and engineered waste management facilities. Spoil that is not required on site can be used by local communities if not contaminated.</p> <ul style="list-style-type: none"> - Insist on waste separation and storage by source; organic wastes, inorganic wastes; recyclables and hazardous wastes in separate containers. - Remove wastes on daily basis. Collect and transport (via waste collectors if appropriate) construction waste to appropriately engineered and licensed solid/hazardous waste management facilities. Hazardous waste will need to be safely and soundly separately stored for disposal to suitably licensed hazardous waste management facilities. Contractor will identify government authorized vendors/ facilities (if any) to take the waste generated for approval by NESCO. | | | | | | |
| Onsite construction activities in general including works for temporary facilities; all works components | Health and safety risks to workers and the community | <ul style="list-style-type: none"> - Contractor is responsible for ensuring H&S of everyone on construction site including visitors and sub-contractor workers regardless they have been formally or informally employed. Ensure adequate health and safety supervision is always on site. - Ensure adequate health and safety supervision is always on site (if staff temporarily off sick or on short term leave of less than a fortnight contractor to provide a named alternate in advance; if safeguard staff are on longer term leave, are posted | <ul style="list-style-type: none"> - EMP/CSEMP requirements successfully implemented as determined through regular site checks, photographic record etc. - No outstanding health and safety grievances from | Throughout construction | √ | √ | √ | Contract cost |

General Mitigation

| Project Activity | Impact or Risk | Mitigation/ Compensation/ Contingency/ Enhancement Measures | Performance Indicator | Timing | Responsibilities (implementation, supervision and monitoring) | | | Budget Source |
|------------------|----------------|---|---|--------|---|-------------------|--------------------------|---------------|
| | | | | | NESCO ⁸ | PIAC ⁹ | Contractor ¹⁰ | |
| | | <p>elsewhere, or resign, contractor to ensure replacement CV is submitted to NESCO upon the contractor becoming aware (with the staff joining the site within one month)</p> <ul style="list-style-type: none"> - Require workers to confirm they have seen and understood the requirements of the health and safety plan before proceeding with the work. - Construction plant and equipment used on or around the site will be modern and fitted with appropriate safety devices. - Ensure adequate health and safety signage is provided – using graphics and in local languages of the workers found on site. - Ensure shaded rest area with adequate drinking water per worker (at least 4 liters/day each) and toilets that are easily accessible and can accommodate the number of workers on site. - MSDS or equivalent data/information in Bangla and other languages of the construction workers are to be readily available to any exposed workers and the first-aid personnel. - Ensure good housekeeping at construction site, storage areas, staff accommodation, etc. To be kept neat and tidy, e.g., no materials, equipment, trash laying around, cleanup worksites so that they are free of debris on daily basis. - If works are not completed within the day the contractor must not leave any hazardous conditions (e.g., unsigned, unfenced, and unlit open excavations without means of | workers, local communities or other interested stakeholders | | | | | |

General Mitigation

| Project Activity | Impact or Risk | Mitigation/ Compensation/ Contingency/ Enhancement Measures | Performance Indicator | Timing | Responsibilities (implementation, supervision and monitoring) | | | Budget Source |
|---------------------------------|---|---|--|--|---|-------------------|--------------------------|---------------|
| | | | | | NESCO ⁸ | PIAC ⁹ | Contractor ¹⁰ | |
| | | escape and emergency contacts in case an accident occurs) overnight unless absolutely no access by public can be ensured. - Road safety standards and norms to be strictly implemented by contractor, construction vehicles to strictly follow road regulations - Designated traffic controllers wearing colored vest will be engaged for traffic management - In the dense urban areas transport equipment only during non-rush hours i.e., avoid the hours of 8 am to 10 am and 4 pm to 10 pm to minimize traffic congestion. - During construction works, ensure qualified first aider and trained fire marshal is always available on-site with an appropriately equipped first aid kit and appropriate fire extinguisher and other firefighting equipment immediately available for use. - Provide an ambulance for more serious cases to transport the patient to the hospital for treatment - Emergency contact number and details for medical, fire, etc. are to be displayed in all construction sites. - Construction workers to be given medical checkup per statutory requirements before being allowed on site; medical records are to be maintained by the contractor's labor officer. | | | | | | |
| Site reinstatement including of | Unanticipated damage to existing public and private | - A photographic record will have been made of the pre-construction condition of land used for temporary facilities before construction to | - Land reinstated to its former condition as | On the completion of construction works prior to | √ | √ | √ | Contract cost |

General Mitigation

| Project Activity | Impact or Risk | Mitigation/ Compensation/ Contingency/ Enhancement Measures | Performance Indicator | Timing | Responsibilities (implementation, supervision and monitoring) | | | Budget Source |
|--|----------------|--|---|-------------------|---|-------------------|--------------------------|---------------|
| | | | | | NESCO ⁸ | PIAC ⁹ | Contractor ¹⁰ | |
| temporary facilities; all works components | property | <p>inform the reinstatement works. After completion of the construction work any temporary structures will be completely removed and the temporary land will be restored to its earlier condition with all waste being removed.</p> <ul style="list-style-type: none"> - All spoil and construction waste and scrap material must be removed on the completion of works and temporarily disturbed sites restored back to their earlier condition. Roads and footpaths utilized to be cleaned and restored back to their previous condition satisfactorily to the community which is using them. - All planned and unanticipated damage to existing public and private property will be restored to pre-project condition and/or compensated at the cost of the contractor. | <p>compared to photographic record.</p> <ul style="list-style-type: none"> - No grievances regarding reinstatement of land and property to its former condition. | handover to NESCO | | | | |

1.2 Part 2 –Upgradation of 9 Existing Substations.

| - Upgradation of Existing Substations | | | | | | | | |
|--|---|---|---|---|---|------|------------|---------------|
| Project Activity | Impact or Risk | - Mitigation / Enhancement Measures | Performance Indicator | Timing | Responsibilities (implementation, supervision and monitoring) | | | Budget Source |
| | | | | | NESCO | PIAC | Contractor | |
| - Detailed Design and Pre-Construction Phase | | | | | | | | |
| Existing Substations audit | Environmental audit has identified gaps in EHS management at existing 9 (nine) substations for upgradation may result in pollution, health and safety risks | <ul style="list-style-type: none"> - NESCO to undertake the corrective actions set out in the Corrective Action Plan (CAP) for existing substations prior to allowing the contractor access to them to start work. Contractor at request of NESCO to address corrective actions as part of their scope of works. - PIAC to submit a report, including photos for each existing substation, on the status of corrective action implementation, compliance with national laws and regulations, and consistency with SPS 2009 requirements to validate NESCO's compliance with the CAP and submit to ADB for clearance. - CAP must be fully implemented and NESCO must receive ADB clearance of this report before the contractor is given access to an existing substation to start work. | Implementation of the corrective action plan, all existing facilities (substations) meet national laws and regulations and are consistent with SPS 2009 requirements prior to the contractor being allowed access to them | Prior to access being granted to the contractor | √ | √ | TBC | Contract cost |

| | | | | | | | | |
|---|--|--|---|--|---|---|---|-------------------------|
| | | <ul style="list-style-type: none"> - Once the contractor has taken access then any non-compliance at the existing substation will become their responsibility so they must ensure they are satisfied CAP is completed. | | | | | | |
| Substation detailed design and construction EHS management planning during pre-construction | Environmental and social impacts of construction and O&M phase -- lack of management of detailed design, construction and O&M leading to environmental degradation, H&S risks for construction and O&M workers as well the local community | <ul style="list-style-type: none"> - Designs to reflect the requirements of the EMP and international engineering best practice/good EHS practices. - Detailed design to minimize the need to cut mature trees that are present at the substation sites - Detailed design to minimize visual impact and clutter with buildings in keeping with the local vernacular. - Landscaping to be included as part of the detailed design to enhance ecology and visual appearance of the substation. - Take a lifecycle approach to detailed design considering the use of construction materials and the energy and water efficiency of building during operation adopting "green building concept" with natural ventilation and rainwater harvesting etc. - Detailed design to ensure all lighting is of energy efficient LED type with solar powered LED lighting where practical Use of fluorescent/HPSV lamps | Detailed Design cleared and approved reflects EMP requirements to minimize impacts and risks on EHS during subsequent stages of the project | Prior to detailed design approval and for implementation during construction | √ | √ | √ | NESCO and Contract Cost |

Om

Dr.

| | | | | | | | | |
|--|--|--|--|--|--|--|--|--|
| | | <p>will be avoided since they are less energy efficient/classed as hazardous waste for purposes of disposal.</p> <ul style="list-style-type: none"> - Outdoor lighting to be installed must be of low intensity with little or no blue wavelength and operated using passive infrared (PIR) technology movement sensors set at person height so as not to be kept permanently on overnight, it must be directional and shielded, so light does not fall outside the site boundary. - Ensure that all substation equipment is raised on foundations located above the flood level including an allowance for climate change plus freeboard. - Construction method statements for landfilling activities must ensure a robust containment wall or bund is installed and that the excess water from sand fill is evaporated or infiltrates to ground, there must be no drainage to or waterlogging of adjacent land and no drainage to or sedimentation of adjacent waterbodies - Existing substations situated in proximity to waterbodies, need | | | | | | |
|--|--|--|--|--|--|--|--|--|

Jim

Dr.

| | | | | | | | | |
|--|--|---|--|--|---|---|---|-------------------------|
| | | <p>to ensure drilling or piling mud as well as noise is managed to avoid adverse effects on water quality, ecology and the adjacent community.</p> <ul style="list-style-type: none"> - SF6 will not be used in, only use of alternative insulation medium (such as vacuum circuit breaker) to be considered - Guidelines of UN Industrial Development Organization (UNIDO) must be followed in handling all transformers marked with PCB or at risk of containing PCBs. - For existing substations with oil leakage comprehensive soil sampling must be undertaken to inform a strategy for remediation, anticipated to involve either the removal of soil off-site for incineration at the Holcim cement plant approved by DOE to take hazardous material or encapsulation if piling can be avoided. | | | | | | |
| | Pollution of soils and water due to discharge of transformer oil or other fuel, oil or chemicals into the environment due to | - Use of PCBs will be prohibited in all new transformers and other substation equipment. Equipment purchased by NESCO or the contractor for use on the project is to be | Detailed Design cleared and approved reflects EMP requirements with copies of equipment purchase letters and MDS included in EMRs. | Prior to detailed design approval and for implementation during construction | √ | √ | √ | NESCO and Contract Cost |

Am

Dr

| | | | | | | | | |
|--|---|---|--|--|--|--|--|--|
| | <p>spills or leaks or discharge of wastewater from substation washrooms</p> | <p>accompanied by letter from the manufacturer stating that it is guaranteed PCB free and to be labelled as PCB free before its installation.</p> <ul style="list-style-type: none"> - Contractor to provide NESCO with Material Data Sheets (MDS) for insulating oil meeting technical specifications for use in new transformers. - Toilets/washrooms to be connected to either or to septic tank with soakaway sufficient distance from waterbodies – any discharge to surface water must meet the project effluent quality standards in Annex 3. - Detailed design of existing substations to locate new transformers, storage areas and septic tanks/soakaway as far away as possible from any surface waterbodies and groundwater sources to reduce pollution risk. If within 500m of surface water or groundwater well further assessment to be carried out by contractor to demonstrate using a source-pathway-receptor model there will be no adverse impact on aquatic ecology or human health. - Detailed design of transformers and fuel, oil chemical, and waste storage areas to incorporate impermeable concrete surface bunded to | | | | | | |
|--|---|---|--|--|--|--|--|--|

Qin

dr

| | | | | | | | | |
|--|--|--|--|--|--|--|--|--|
| | | <p>110% volume which is not connected to the drainage system to collect spills and leaks.</p> <ul style="list-style-type: none"> - Detailed design of fuel, oil chemical, and materials and waste storage areas to provide for a covered storage area of sufficient size to accommodate all anticipated storage requirements with segregation of wastes, ensure storage areas can be locked, are well-ventilated and will not reach extreme temperatures. Ensure space also provided in the storage area for solid and hazardous waste garbage bins to be stored. - Provide spill prevention kits (sorbent pads, loose sorbent material, etc.) at storage areas and other at-risk locations within clearly labelled containers. - Identify the presence of floodplain or depressions that get waterlogged in the rainy season and avoid them during detailed design. - Conduct a flood and drainage risk assessment and incorporate effective drainage design (allowing for climate change) to prevent possible flooding or waterlogging of the substation during the wet season, whilst ensuring that | | | | | | |
|--|--|--|--|--|--|--|--|--|

Am

dr

| | | | | | | | | |
|--|---|--|--|--|---|---|---|-------------------------|
| | | <p>surface runoff from the project site is no more than the existing site runoff rate.</p> <ul style="list-style-type: none"> - Substation designs must ensure that existing drainage flows/drains/culverts are not blocked and avoid exacerbating flooding or waterlogging of adjacent land e.g. due to removing storage capacity from the floodplain. - No drainage water will be permitted to discharge direct to surface water, oil interceptors are to be fitted on all drainage to catch oil spill. | | | | | | |
| | Health and safety risks related to fire safety and emergency response | <ul style="list-style-type: none"> - Detailed design of control buildings to follow national building and fire safety standards as well as international good practice - Detailed design of building to include emergency exits with emergency exit signage - Provide fully stocked, in-date first aid kit installed in a prominent, signed position, first aid posters and emergency contacts to also be displayed - Provide eye wash station and water supply to shower located near the storage areas for fuel/oil/chemicals - Detailed design of substations to include fire safety measures including detector, alarm, and firefighting equipment in | Detailed Design cleared and approved reflects EMP requirements | Prior to detailed design approval and for implementation during construction | √ | √ | √ | NESCO and Contract Cost |

Orin

Dr.

| | | | | | | | | |
|--|--|---|--|--|---|---|---|-------------------------|
| | | <p>accordance with national regulations and IFC EHS Guidelines on OHS.</p> <ul style="list-style-type: none"> - Provide sand buckets, full of sand, placed in a prominent, signed location near to fire-risk locations such as transformers and oil storage areas. - Provide fire extinguishers (including for oil and electric fires) in a prominent, signed location near to fire-risk locations such as transformers and oil storage areas with service and expiration dates clearly labelled. - Provide automatic fire alarm and fire suppression system in the control buildings along with posters on fire safety. - Provide fire walls on all the transformers - All electrical hazards with feature written and visual warning signs that meet the IEEE standards to include the ISO 7010 "Hazard Type: Electrical Symbol" warning of the risk of electrocution. | | | | | | |
| | Impacts to health and safety of O&M workers and the public | <ul style="list-style-type: none"> - Use of any asbestos containing materials is prohibited. - Include in the design of all substations (if not already present or in poor condition) and around transformers a secure wall or fence sufficiently high it cannot be climbed over | <ul style="list-style-type: none"> - Detailed Design cleared and approved reflects EMP requirements - Compliance with ICNRP occupational/community EMF exposure levels (reference and peak values) | Prior to detailed design approval and for implementation during construction | √ | √ | √ | NESCO and Contract Cost |

Am

dr

| | | | | | | | | |
|--|--|--|--|--|--|--|--|--|
| | | <p>with lockable entry featuring written and visual warning signs to include the ISO 7010 “Hazard Type: Electrical Symbol” warning of the risk of electrocution.</p> <ul style="list-style-type: none"> - Indoor work areas at substations to be well ventilated and naturally or artificially well-lit in accordance with national regulations and the IFC EHS Guidelines on OHS. For control buildings provide adequate natural and/or artificial lighting levels to meet the IFC EHS Guidelines on Occupational H&S (Table 2.3.3. Minimum Limits for Workplace Illumination Intensity) - Detailed design of substations to ensure EMF levels within the substation boundary are within international good practice levels as per International Commission on Non-Ionizing Radiation Protection (ICNIRP) (reference and peak values) for occupational exposure;¹³ in areas where EMF levels could be exceeded posting of written and visual warning signs. Use of shielding equipment/materials to decrease EMF exposure as | | | | | | |
|--|--|--|--|--|--|--|--|--|

¹³ <https://www.icnirp.org/cms/upload/publications/ICNIRPEmfgdl.pdf>

Om

dr

| | | | | | | | | |
|--|--|--|--|--|--|--|--|--|
| | | <p>required.</p> <ul style="list-style-type: none"> - Pit latrines and disposal of untreated sanitary wastewater to surface or groundwater is prohibited. Staff will reside off site but detailed design of substations to include adequate sanitation and welfare facilities for all workers to be posted at or visiting the substations including indoor kitchen (if possible), eating and rest areas and adequate number of indoor toilets/washrooms (one per six staff and separate for men/women with running water hand washing facilities) which are connected to septic tank with soakaway. - Provide a dedicated shelter and rest area for the 24-hour security guards, shielding them from rain, wind, and extreme (hot and cold) temperatures. - Disposal of worker generated waste (e.g., plastic bottles) on-site is prohibited and adequate waste storage areas to be incorporated into the detailed design. Composting of food waste may be permitted on-site if detailed design incorporates enclosed composting facilities (enclosed to avoid attraction of vermin etc.) located away from accommodation and any properties outside the site boundary. | | | | | | |
|--|--|--|--|--|--|--|--|--|

Orin

dr

| | | | | | | | | |
|--|--|---|--|--|--|--|--|--|
| | | <ul style="list-style-type: none"> - Source of drinking water that meets drinking water standards to be provided to substations. If any surface or groundwater sources are proposed for use in substations, Contractor is to undertake a baseline water quality sampling per EMoP (Annex 2) to confirm its suitability for use. If drinking water standards are not met, detailed design to consider alternative source or include water treatment facilities (RO) at the substation to facilitate safe drinking water supply. Detailed design to include water meters for monitoring of water abstracted. - Provide gated, safe vehicular access for entry/exit off the public highway having adequate sight lines for all drivers and warning signs of entrance as well as adequate parking for cars. - Final surface level of substation equipment will be at least 1 m above the highest flood level including an allowance for climate change based on the findings of the climate change assessment prepared for the Project - Foundations to be constructed in such a way as to be adequately drained to prevent | | | | | | |
|--|--|---|--|--|--|--|--|--|

Orin

Dr.

| | | | | | | | | |
|--|---|---|--|--|---|---|---|-------------------------|
| | | <p>washouts and flooding impacts to adjacent land.</p> <ul style="list-style-type: none"> - Junctions between new access roads to substation and existing main roads should not impede or damage the latter nor pose blockage to any associated drainage channels, irrigation infrastructure, etc. - If crossing of drainage channels is required for substation entrance creation, a bridge or culvert is to be used to maintain the natural flow of the drain. These should be designed to 1:100 years return period with the invert level of culverts below the bed level to enable the natural substrate to return. | | | | | | |
| | Impacts from dust generated by earthworks | <ul style="list-style-type: none"> - Detailed design of substations to minimize cut and fill and land raising to reduce the extent of sand filling/earthworks and thus dust generation during construction, also maximize reuse of spoil to minimize the need for disposal off site. - During detailed design, contractors will quantify extent of sand filling/earthworks required, amount of spoil to be generated and location for disposal of excavated spoil through landscaping within the site boundary – generation of excess spoil to be avoided. | Detailed Design cleared and approved reflects EMP requirements | Prior to detailed design approval and for implementation during construction | √ | √ | √ | NESCO and Contract Cost |

Om

Dr.

| | | | | | | | | |
|--|---------------------------------|---|---|--|---|---|---|-------------------------|
| | Impacts due to substation noise | <ul style="list-style-type: none"> - Detailed design to ensure maximum sound power level of equipment at 1 m is 85 dBA through use of sound attenuation, in areas where these noise levels will be exceeded OHS noise warning signage identifying that ear protection to be worn must be installed as part of detailed design. - Detailed design of transformers and other noise sources to be located as far as practical from the substation site boundary since noise diminishes with distance. - Contractors will be required to measure and confirm the distance from their detailed design and construction works to sensitive receptors to confirm if the noise standards can be met. If any properties are within 100m of the substation site boundary¹⁴ then baseline measurements must be carried out during detailed design (refer to EMoP Annex 2) by the contractor who will also undertake quantitative noise | <ul style="list-style-type: none"> - Detailed Design cleared and approved reflects EMP requirements - Compliance with noise standards applicable to the substation location per Annex 3 | Prior to detailed design approval and for implementation during construction | √ | √ | √ | NESCO and Contract Cost |
|--|---------------------------------|---|---|--|---|---|---|-------------------------|

¹⁴ Construction impacts and operational noise exceedance in silent zone might be possible up to 100m. However, if the louder types of piling (impact or vibratory hammers) that generate over 85 dBA are intended to be used by the contractor baseline measurements must be carried out at substation sites with any properties present in 50m due to the increased impact area that will result.

| | | | | | | | | |
|--|--|--|--|--|--|--|--|--|
| | | <p>assessment using internationally recognized noise modelling software of (i) the detailed design considering low frequencies associated with transformer hum and (ii) construction methods to confirm that noise standards per Annex 3 can be achieved for the substation alone without additional noise mitigation – industrial levels must be achieved at the site boundary with residential levels at the nearest properties with silent levels achieved when schools or other silent zone receptors are present. If residential properties or other sensitive receptors are near the substation boundary, then measurements must be carried out during detailed design and baseline noise calculations (modelling) considering low frequencies associated with transformer hum will be undertaken by the Contractor to demonstrate that the noise standards/guidelines can be met. If background noise levels already exceed the standards/guidelines the design must ensure that noise levels</p> | | | | | | |
|--|--|--|--|--|--|--|--|--|

Orin

Dr.

| | | | | | | | | |
|--|--|---|--|--|--|--|--|--|
| | | <p>result in a <3dBA increase in background.</p> <ul style="list-style-type: none"> - Given transformers are generally in the range 60-80 dBA at 1m if outdoors they are to be located at least 5 m inside the substation site boundary but this distance will need to be increased to between 20m – 100m depending on the land use adjacent to the substation for noise limits to be met without additional attenuation. The quietest available equipment with manufacturer-supplied noise mitigation will be installed. If noise levels cannot be met through siting and design alone detailed design to incorporate acoustic barrier designed to international good practice around either the noise source and/or substation site boundary to attenuate noise to level such that noise levels at the receptors will be met. As operational noise is permanent the acoustic noise barrier will need to be a permanent installation as part of the detailed design - Contractor to avoid soil compaction, piling, blasting and other vibration inducing activities as much as possible. The quietest equipment available will be used, noise attenuation measures will | | | | | | |
|--|--|---|--|--|--|--|--|--|

Jim

Dr.

| | | | | | | | | |
|--|--|--|--|--|--|--|--|--|
| | | <p>include, (i) fitting of high efficiency mufflers to the noise generating equipment; and (ii) keeping acoustic enclosures around piling/drilling equipment. For piling it will not be possible to use the louder types of piling (impact or vibratory hammers) that generate over 85 dBA without resulting in a significant impact because noise from piling equipment of 120 dBA at 1m would exceed 85dBA, the level at which hearing damage is caused at adjacent properties if found within 100m. If noise levels are still exceeded a temporary acoustic noise barrier must be provided or alternatively temporary relocation of occupants during works to a rented property.</p> <ul style="list-style-type: none"> - In locations where soil compaction, piling, blasting and other vibration inducing activities are unavoidable Contractor to identify properties within the zone of influence and undertake pre-construction structural surveys to identify level of risk with reference to the guideline vibration levels per Annex 3. - If there is a risk of structural damage to properties due to their current condition, consider alternative construction | | | | | | |
|--|--|--|--|--|--|--|--|--|

Orin

Dr.

| | | | | | | | | |
|--|--|---|---|---|---|---|---|---------------|
| | | <p>methods or temporary relocation of occupants during works if at risk to a rented property.</p> <ul style="list-style-type: none"> - Consider the need to install monitors to monitor structural movement. Structural or cosmetic damage to be repaired by Contractor to at least pre-project condition at their own cost. | | | | | | |
| | Impacts to surface and groundwater resources | <ul style="list-style-type: none"> - Construction activities must be planned not to limit the availability of or restrict access to water sources (e.g., groundwater wells) used by local communities; natural flow of any surface water or drains must not be obstructed or if not possible diverted through a drainage system to another direction. - Any piling or excavation works within 500m of groundwater wells used as a drinking water source by local communities will require pre-construction and post construction water quality monitoring against drinking water standards to ensure there is no contamination of the water supply. - Construction water to be sourced from an existing licensed commercial supplier (preferred option especially for potable water supplies), where | <ul style="list-style-type: none"> - Monitoring data demonstrates compliance with national standards - No unresolved grievances regarding water resources | Prior to mobilization and site establishment and for implementation during construction | √ | √ | √ | Contract cost |

Am

dr

| | | | | | | | | |
|--|--|--|--|--|--|--|--|--|
| | | <p>available, or rainwater harvesting. If using an existing surface water or an existing borewell for construction water, permissions to be obtained from the relevant authorities together with the agreement of local communities.</p> <ul style="list-style-type: none"> - Prior agreement is required from local community users to use any existing surface water/borewell or local piped water either temporarily during construction or permanently for substations; in cases where use of local water source is not agreed, contractor to import tanked water to the project area. - Contractor will only use groundwater after it has been confirmed through assessment and confirmed by competent authorities and community that there will be no additional stress on groundwater resources as a result. - Permissions of any new borewell installation (for construction or permanent supply to substation) to be obtained together with agreement of local communities before abstraction, include water meter for monitoring of water abstracted. - Contractor to avoid piling | | | | | | |
|--|--|--|--|--|--|--|--|--|

Qin

dr

| | | | | | | | | |
|--|-----------------------------------|---|--|---|---|---|---|---------------|
| | | <p>activities as much as possible. If needed a management plan will be prepared for approval. Oil will not be used for drilling or piling fluid. The piling management plan will include measures to avoid water pollution from the use of any bentonite clay slurry - adequate bunding must be provided around piling activities to contain piling mud and decanting ponds will need to be fully enclosed to avoid spills or leaks to adjacent land.</p> <ul style="list-style-type: none"> - Piling fluid must not be intentionally or unintentionally disposed of to surface water untreated or be allowed to damage adjacent land. - Sediment laden surface water runoff and discharges must be disposed of to open ground for percolation or passed through a sedimentation tank having adequate settlement tank, to obtain at least 50 mg/l TSS, before being allowed to enter surface water. - Use of piling mud treatment equipment to be considered where space | | | | | | |
| | Impacts of temporary access roads | <ul style="list-style-type: none"> - All substations will be accessed via the existing road network and no new access road will be constructed, although new entranceways may be created onto main roads. Junctions | <ul style="list-style-type: none"> - Access roads reinstated to their former condition as compared to photographic record. - No grievances regarding reinstatement | Prior to mobilization and site establishment and for implementation during construction | √ | √ | √ | Contract cost |

Qin

Dr.

| | | | | | | | | |
|--------------------------------|---|---|---|---|---|---|---|---------------|
| | | <p>between new entrances and existing roads will not impede or damage the latter nor any associated drainage channels, public utilities, etc. Adequate sight lines will be provided for safe entrance and exit of vehicles.</p> <ul style="list-style-type: none"> - A photographic record will be made of the pre-construction condition of access roads to inform the reinstatement works. - After completion of the construction work access roads will be restored to their original condition. | <p>of access roads to their former condition.</p> | | | | | |
| Construction Phase | | | | | | | | |
| Onsite construction activities | Asbestos may be encountered at the project site or in the demolished buildings during the construction phase. | <ul style="list-style-type: none"> - If asbestos is encountered but does not need to be disrupted and is not weathered and appears in good condition, consider leaving it where it is, as main health risks occur when asbestos is moved. However, signage to be installed to warn of presence and to ensure it is not touched. - If any asbestos will be disturbed by construction works, it must be removed following national requirements and international good practice per EHS General Guidelines on OHS and ADB Good Practice Guidance for the Management | <ul style="list-style-type: none"> - EMP/CSEMP requirements successfully implemented as determined through regular site checks, photographic record etc. - No workers and communities affected by exposure to ACMs. | Construction, prior to demolition works | √ | √ | √ | Contract cost |

| | | | | | | | | |
|--|-------------------------------------|---|---|-------------------------|---|---|---|---------------|
| | | <p>and Control of Asbestos and disposed of as hazardous waste material. In doing so the contractor will need to employ a specialist subcontractor who will develop a safe method statement and provide PPE protecting against asbestos to their workers; and</p> <ul style="list-style-type: none"> - Removal will require the deliberate soaking and confining of the asbestos, securing the entire area to stop asbestos fibers from escaping etc. | | | | | | |
| | Impacts due to dust from earthworks | <ul style="list-style-type: none"> - Plan the construction site layout so that machinery and dust-causing activities are located away from receptors, as far as is possible. - Sprinkle water to suppress dust, especially during dry and windy season. - Erect solid screens or barriers around the dusty activities or the site boundary that are at least as high as any stockpiles on site to fully enclose operations. - Contractors to undertake quantitative air quality monitoring as per the EMoP (Annex 2). In addition to quantitative monitoring (as per EMoP) contractors will | <ul style="list-style-type: none"> - EMP/CSEMP requirements successfully implemented as determined through regular site checks, photographic record etc. - No exceedance of air quality levels (Annex 3) or increase in baseline air pollution levels where they are already exceeded. - No outstanding grievances related to impacts from dust and air pollution. | Throughout construction | √ | √ | √ | Contract cost |

Qin

Dr.

| | | | | | | | | |
|--|-----------------------------------|--|--|-------------------------|---|---|---|---------------|
| | | <p>undertake weekly dust soiling checks of surfaces of adjacent properties during earthworks and help with cleaning of external surfaces of property if dust is evident.</p> <ul style="list-style-type: none"> - If air quality levels are exceeded, an increase in existing background air pollution is recorded where they were already exceeded, or complaints are received contractor will be required to implement additional dust mitigation e.g., barricading/isolating sources of dust, use of wheel wash, adjusting working methods, to ensure the levels are met. | | | | | | |
| | Impacts due to construction noise | <ul style="list-style-type: none"> - During night (6am to 10pm) no works will be permitted at substations. - Contractor's maximum working hours (including the movement of heavy vehicles for construction on off-site access roads) will be 7 am – 7 pm. - Residents within 500m will be informed well in advance of the construction schedule for noisy activities taking place on-site. Noisy construction activity at substations (especially demolition and piling works) will only take place between the hours of 10 am - 4 pm. No noisy work and heavy vehicle movements will take place on | <ul style="list-style-type: none"> - EMP/CSEMP requirements successfully implemented as determined through regular site checks, photographic record etc. - No exceedance of noise levels (Annex 3) or increase in baseline noise levels where they are already exceeded. - No outstanding grievances related to impacts from noise and vibration. | Throughout construction | √ | √ | √ | Contract cost |

Am

Dr

| | | | | | | | | |
|--|--|---|--|--|--|--|--|--|
| | | <p>Fridays and during school/college/university exam periods. No work on Saturday, holidays and festival days. Sensitive receptors to be consulted with any other special days when they would wish noise levels to be minimized.</p> <ul style="list-style-type: none"> - For substations with properties in 50m distance, loud construction noise must be limited to only very short periods of activity to minimize disturbance. - Layout substations to keep noisiest construction works the furthest distance possible from adjacent receptors and adopt construction methods that ensure noise generated from construction is minimized. If the noise levels at the site boundary or receptors will exceed the required noise levels, are more than 3dBA above background when already exceeded, or there are complaints then a temporary acoustically designed noise barrier will need to be installed around the substation perimeter to be able to meet required noise level. - Sound levels received by workers must not be over 85 dB(A) during continuation of 8 working hours without wearing | | | | | | |
|--|--|---|--|--|--|--|--|--|

Qin

dr

| | | | | | | | | |
|--|---------------------------------------|---|---|-------------------------|---|---|---|---------------|
| | | <p>PPE.</p> <ul style="list-style-type: none"> - Contractors to undertake quantitative noise monitoring as per the EMoP (Annex 2). If noise levels are exceeded, adjust construction practices and mitigation measures as required to ensure compliance with them. - Provide training to the operators of construction equipment on potential noise sources and the operating techniques to minimize noise emissions. | | | | | | |
| | Impacts due to land development works | <ul style="list-style-type: none"> - No borrow area or quarry will be opened by the contractor to obtain land fill material. No dredging will be undertaken by the contractor. Ensure sand and gravel for substation land filling is from an existing government licensed sand and gravel supplier operating legally permitted sites i.e. ensure no illegally extracted sand and gravel is used for the project. Copies of licenses of the supplier to be obtained by contractor prior to the commencement - The adjacent properties to be informed at least one month prior that the land development/infill work is to be commenced. - Conduct land development/infilling during the | <ul style="list-style-type: none"> - EMP/CSEMP requirements successfully implemented as determined through regular site checks, photographic record etc. - No outstanding grievances related to land development activities | Throughout construction | √ | √ | √ | Contract cost |

Am

dr

| | | | | | | | | |
|--|--|--|--|--|--|--|--|--|
| | | <p>dry season when the site is not waterlogged to minimize the risk of sediment laden runoff</p> <ul style="list-style-type: none"> - Ensure land fill works are commenced at the start of the dry season - To avoid cumulative impact on the road network since a large number of trucks will be needed to import material, plan the import of material in a staggered manner to reduce the number of daily traffic movements ensuring no congestion is allowed to build up at the site entrance; parking area for trucks is to be provided off the access road. - Erection of a robust bund or wall (e.g. sheet pile or earthen bund) to contain the mud sand whilst the water evaporates or discharges to ground. Condition of the bund or wall must be checked daily to ensure no leak. - There should be no discharge of water to the adjacent land or drainage channels; no waterlogging of adjacent land and no sedimentation of waterbodies adjacent. Photographic record of the access road and adjacent land and properties to be taken before the start of land development/infill works. Removal of all dumped waste | | | | | | |
|--|--|--|--|--|--|--|--|--|

Orin

dr

| | | | | | | | | |
|--|--|---|--|--|--|--|--|--|
| | | <p>from the site for disposal to a suitably licensed waste management facility prior to land development as no waste must be buried under the infill.</p> <ul style="list-style-type: none"> - Water quality baseline monitoring data to be taken from the adjacent waterbodies before the start of infill works. - The water quality (pH, turbidity, TDS, TSS, DO) of the adjacent waterbodies will be monitored daily during the infill activity and works must halt immediately upon any deterioration with corrective action taken to bring the water quality back to baseline before continuing works. No exceedance of the water quality standards as are mentioned in Appendix. - If any damage occurs to the adjacent land or waterbodies due to the infill activity, then this must be rectified or compensated by the contractor. - Following infill, the dry raised land must be seeded, and the slopes planted with native grass species, short water tolerant plants and reeds at the base to prevent soil erosion whilst the landfill settles for construction. - NESCO to ensure their environmental specialist or PIAC supervises and monitors infilling activities on a daily | | | | | | |
|--|--|---|--|--|--|--|--|--|

Orin

Dr.

| | | | | | | | | |
|--|---|--|--|-------------------------|---|---|---|---------------|
| | | basis and in doing so ensures works are undertaken following national laws and regulations and the EMP requirements. | | | | | | |
| | Impacts due to lack of hazardous waste management, solid waste management and housekeeping at substations | <ul style="list-style-type: none"> - The guidelines of UN Industrial Development Organization (UNIDO) must be followed in handling all transformers since due to recycling of oil none can be guaranteed PCB free; and the contractor should test all transformers and stored (waste) oil that is disturbed by the project. If already tested by DOE then the test results to be obtained for monitoring purposes and there is no need for them to be retested. - Treat contaminated soil in accordance with the approved remediation strategy with removal of contaminated soil off-site for incineration at the Holcim cement plant approved by DOE to take hazardous material or encapsulation if piling can be avoided and no risk of exposure using source-pathway-receptor approach. - Contractor to dispose of any transformers, waste oils and disturbed asbestos containing materials (ACMs) if encountered in the demolished structures during the construction phase as hazardous wastes. - Defunct batteries (e.g., lead | <ul style="list-style-type: none"> - EMP/CSEMP requirements successfully implemented as determined through regular site checks, photographic record etc. - No exceedance of air, water, soil levels (Annex 3) or increase in baseline contamination levels where they are already exceeded. - No outstanding grievances related to impacts from hazardous waste management. | Throughout construction | √ | √ | √ | Contract cost |

Orin

Dr.

| | | | | | | | | |
|--|--|--|--|--|--|--|--|--|
| | | <p>acid) installed at the substations at their end-of-life will need to be disposed of as hazardous waste.</p> <ul style="list-style-type: none"> - If PCBs are present in transformers or waste oil DOE to be consulted to confirm the environmentally safe and sound disposal route available in Bangladesh – the agreed method is still to be determined and may involve management in country or transboundary export to nearby country. - Place a high emphasis on good housekeeping practices within the existing substation and any construction camp to minimize slip, trip and fall hazards, pollution risks etc. - Maintain all construction sites and any construction camp in a clean, tidy and safe condition - Provide and maintain solid and hazardous waste storage facilities at the existing substation and any construction camps to store all wastes before transportation to appropriately engineered and licensed solid/hazardous waste management facilities. | | | | | | |
|--|--|--|--|--|--|--|--|--|

Om

Dr.

| | | | | | | | | |
|---|---|--|---|--|---|---|---|---------------|
| | Site restoration | <ul style="list-style-type: none"> - Rehabilitate any disturbed areas beyond the substation infrastructure footprint to through revegetation and landscaping using native species. - All spoils, construction waste and material scrap after construction must be removed. The substation boundaries to be cleared of construction waste, footpaths and surrounding to be cleared and restored satisfactorily to the community staying near the substation. | <ul style="list-style-type: none"> - EMP/CSEMP requirements successfully implemented as determined through regular site checks, photographic record etc. | On the completion of construction works prior to handover to NESCO | √ | √ | √ | Contract cost |
| O&M Phase (Measures to be Implemented by NESCO management) | | | | | | | | |
| Operation and maintenance activities | EHS impacts and risks of substations in general | <ul style="list-style-type: none"> - Prepare operational SOP for substations covering pollution control, solid and hazardous waste management, health and safety risk assessments and management plans addressing both occupational and community risks and including permit to work system of critical activities such as electrical or work at height and emergency preparedness and response provisions (content will be similar to those of construction phase but tailored to reflect operational aspects) - Substation workers will need to be trained in SOP/ OR (Annex 4, ECP 16 & 18) and good housekeeping practices | <ul style="list-style-type: none"> - Compliance with GOB regulations - No fatalities or lost time incidents 100% of H&S incidents including near miss recorded, immediately investigated, and corrective action taken to prevent repeat. - Compliance with noise levels: 1- hour LAeq 70 dB(A) at the site boundary, 60dB(A) within commercial zones, 45 dB(A) at the nearest residential properties including those in commercial zones and 40dB(A) | Throughout the O&M Phase | √ | | | NESCO |

| | | | | | | | | |
|--|---|---|--|--|--|--|--|--|
| | | <p>including how to clean up oil/fuel spills and dispose of contaminated sorbent material which would be treated as hazardous waste etc.</p> <ul style="list-style-type: none"> - During maintenance activities mitigation measures applicable to the construction phase are also applicable to NESCO maintenance workers or contractors and are to be followed - Material Safety Data Sheets for all fuel/oil/chemical kept on site to be posted - Records volumes of all type of wastes generated and keep transfer records at the substation with copies of the waste management company's licenses on file. - Defunct batteries (e.g., lead acid) installed at the substations at their end-of-life will need to be disposed of as hazardous waste. - During O&M, internal audits will be undertaken by the NESCO ESS Unit Environment Officer and Health and Safety Officer | <p>within 100m of silent zones</p> <ul style="list-style-type: none"> - Compliance with ICNRP occupational/community EMF exposure levels (reference and peak values) at substations - EMP/CSEMP requirements successfully implemented as determined through regular site checks, photographic record etc. - No outstanding grievances from local communities or other interested stakeholders | | | | | |
| | Occupational health safety of maintenance staff - accident risk | <ul style="list-style-type: none"> - Maintain incident logbook and medical tests / health check-up of staff - Provide everyone who enters the SS with an OHS induction - Keep vents/windows unblocked | - | | | | | |

| | | | | | | | | |
|--|--|--|--|--|--|--|--|--|
| | | <p>and replace defunct bulbs/lights immediately</p> <ul style="list-style-type: none"> - Ensure all SS workers receive basic first aid and firefighting training with annual refreshers - Ensure that at least one staff at SS is fully trained as a first aider and fire marshal - Annual mock drills for fire, oil spills, etc. and update the Emergency Preparedness and Response Plan based on drill outcomes during operation phase - Maintain fully stocked, in-date first aid kit, keep first aid posters and emergency contact lists that are posted up to date - Maintain firefighting systems including in-date fire extinguishers and full sand buckets and keep fire safety posters up. Carry out regular inspections and periodic maintenance to ensure electrical standards are being upheld - Keep emergency exits clear at all times and maintain emergency exit signs Maintain written warning signages including the ISO 7010 Hazard Type: Electrical Symbol warning of the risk of electrocution. - Collect, segregate, and store in the designated and labelled | | | | | | |
|--|--|--|--|--|--|--|--|--|

Orin

Dr.

| | | | | | | | | |
|--|--|---|--|--|--|--|--|--|
| | | <p>storage areas all wastes including food wastes for onward disposal as per construction.</p> <ul style="list-style-type: none"> - Undertake regular pest control using integrated pest management approach Maintain vegetation at the SS that poses a health and safety hazard Prohibit the use of herbicides, pesticides or burning to control any vegetation growth or to manage vegetation waste. - O&M to be performed only by suitably qualified and experienced workers who are regularly trained staff of NESCO or a contactor under supervision of a Health and Safety Officer following the SOP for H&S. - O&M workers to be given required PPE and other requisite safety equipment, provide sufficient PPE spares available on site for visitors etc. - Sanitation and welfare facilities as per construction will also be required for O&M workers. - Continue to provide potable drinking water supply meeting GoB drinking water standards (regular testing of drinking water is included in EMoP scope) - Cleaning of toilets on daily basis, use of disinfectant and | | | | | | |
|--|--|---|--|--|--|--|--|--|

Om

dr

| | | | | | | | | |
|--|--|--|---|--|--|--|--|--|
| | | <p>floor cleaners; keep toilets/septic tank/soakaway maintained.</p> <ul style="list-style-type: none"> - Periodic spot monitoring using mobile phone app of noise levels and ambient EMF for substations at the boundary fence/near transformers to ensure they are below the occupational/ community noise levels and ICNRP occupational/ community EMF exposure levels - No breaches of compliance with regulatory requirements or GIIP including ambient air quality and noise standards. - No outstanding dust, noise and general disturbance and disruption grievances from local communities or other interested stakeholders. | | | | | | |
| | <p>Community H&S risks – impact on surrounding community, noise, EMF, accidents etc.</p> | <ul style="list-style-type: none"> - Maintain security and prevent entry by the local community by maintaining adequate boundary fencing or wall, always keeping control room doors and gates shut, and having security persons present 24x7 to prevent unauthorized public access and trespass. - Maintain written warning signages including the ISO 7010 Hazard Type: Electrical Symbol warning of the risk of electrocution. - Regular checks and periodic | - | | | | | |

Am

dr

| | | | | | | | | |
|--|---|---|---|--|--|--|--|--|
| | | <p>maintenance of equipment like transformers and capacitors to minimize corona noise emissions.</p> <ul style="list-style-type: none"> - No breaches of compliance with noise standards during O&M. - No outstanding noise grievances from local communities or other interested stakeholders. - Ensure continued stakeholder communication, including periodic community awareness sessions on electrical safety, EMF exposure, and access to the GRM during operation | | | | | | |
| | Use of mineral oil for transformers – accidental spillage contaminating both land and water | <ul style="list-style-type: none"> - Maintain inventory of transformers on site, make, model, risk of PCBs (if any) and other details including transformer test report, details any maintenance works undertaken, dates oil changes, leakage incidents etc. - Carry out regular inspections and periodic preventive maintenance to minimize oil leakages; ensure valves, nuts and bolts are fully functional and tightly secured, ensure rubber seals of radiators are intact - The acceptance of mineral oil at substation to be accompanied with Material Safety Data Sheet and | - | | | | | |

Qin

dr

| | | | | | | | | |
|--|---|--|--|--|-----|-----|-------|--|
| | | <p>certification that it is PCB free.</p> <ul style="list-style-type: none"> - Waste oil to be disposed as hazardous waste using appropriately licensed waste management company with environmentally safe and sound storage, transport, and disposal - Maintain spill management materials (sorbent pads, loose sorbent material, sand, etc.) next to storage areas for immediately soaking up any leaks or spills that do accidentally occur | | | | | | |
| | Local drainage system may get clogged due to improper management of solid waste and other materials within the substation | <ul style="list-style-type: none"> - Solid waste and other materials must not be dumped in the drains. Maintain drains regularly to enable free flow of water at all times. - Blocked drains to be immediately cleaned and debris disposed on a regular basis. | <ul style="list-style-type: none"> - Regular maintenance - Clean and working drain | | N/A | N/A | NESCO | |

Annex 2: Quantitative Monitoring

Qualitative Monitoring is reflected in the Mitigation Plan (Annex 1)

Part 1 – General (All Works)

| General (All Works) | | | | | | | | |
|---|---|--|---|--|--|---|---|---|
| Environmental Parameters to be Monitored | Location | Time/Frequency/Duration | Method of Measurements | Performance Standard / Quantitative Targets | Responsibilities | | | Equipment and Monitoring Cost (Million BDT) |
| | | | | | PIU | PIAC | Contractor | |
| Construction Phase | | | | | | | | |
| Construction materials and waste management: record keeping | All construction sites, including construction stores and labor camps | Ongoing throughout construction, monthly reporting of records kept by the contractor | - Keep records of all types of materials used and waste produced by type, volume/weight. Document waste handling full-cycle through transfer notes (including type, volume, source, transport, intermediaries if any, and final treatment or disposal facility with its license and capacity) | Use of materials and transfer of all construction wastes documented with all wastes disposed of in an environmentally safe and sound manner. | PIU to ensure record keeping by contractor and to report in EMR to ADB | PIAC to supervise contractor and support PIU in checking compliance | Contractor to keep records and report to PIU in monthly progress reports | Part of contract cost, include costs of implementing EMoP as BOQ line |
| Hazardous materials– incidents | All construction sites, including construction stores and labor camps | Ongoing throughout construction, monthly reporting of records kept by the contractor | - Records of pollution incidents (e.g., type of material spilled, amount in kg or m ³ and action taken to clean up) - Carry out visual inspection and interviews with workers and the community to identify if any unrecorded incidents occurred | - No pollution incident affecting soil or water quality - zero major incidents occurred. - Minor incidents responded to in accordance with EMP response plan procedures with lessons learnt for future if they occur. | - PIU to ensure record keeping by contractor and to report in EMR to ADB per SCC/ECC - Any pollution incident to be reported within 24 hours to ADB | PIAC to supervise contractor and support PIU in checking compliance | - Contractor to keep records and report to PIU in monthly progress reports - Any pollution incident to be reported within 24 hours to PIU and PIAC | Part of contract cost, include costs of implementing EMoP as BOQ line |
| Occupational and community health and safety | All construction sites, including | Ongoing throughout construction, monthly reporting of records kept by the contractor | - Keep records of near misses, minor, lost time, and fatal health and safety incidents related to | - Zero lost time incidents or fatalities (among workers and community) - All near miss, minor, lost time, and fatal incidents | - PIU to ensure record keeping by contractor and | PIAC to supervise contractor and support PIU in | - Contractor to keep records and report to | Part of contract cost, include costs of |

| General (All Works) | | | | | | | | |
|--|---|--|---|--|---|--|--|--|
| Environmental Parameters to be Monitored | Location | Time/Frequency/Duration | Method of Measurements | Performance Standard / Quantitative Targets | Responsibilities | | | Equipment and Monitoring Cost (Million BDT) |
| | | | | | PIU | PIAC | Contractor | |
| incidents: record keeping | construction stores and labor camps | | the project, compile records from construction sites; carry out interviews with workers and the community to identify if any unrecorded incidents occurred. | having adequate response plan, with lessons learnt for future if they occur. | to report in EMR to ADB - Any lost time incident or fatality to be reported within 24 hours to ADB | checking compliance | PIU in monthly progress reports - Any lost time incident or fatality to be reported within 24 hours to PIU and PIAC | implementing EMoP as BOQ line |
| Health and Safety: construction drinking water supplies | All construction sites, including construction stores and labor camps | Monthly, Ongoing throughout construction, monthly testing or reporting of records kept by the contractor | - Water sample is to be taken in a clean, non-contaminated, well-sealed container and tested within the next 48h. Drinking water quality tests against Bangladesh drinking water standards by accredited laboratory (physical, chemical, and bacteriological tests including arsenic levels) where the contractor provides a surface or groundwater drinking water supply or sources where supplier is unable to provide water quality test results. - Alternatively, documentary evidence | Drinking water provided meets national drinking water standards | PIU to ensure monitoring undertaken by contractor and to report in EMR to ADB | PIAC to supervise measurements in the field and support PIU in checking compliance | Contractor to undertake measurements and report to PIU | - Water quality tests by accredited laboratory. - Part of contract cost, include costs of implementing EMoP as BOQ line |

| General (All Works) | | | | | | | | |
|--|----------|-------------------------|---|---|------------------|------|------------|---|
| Environmental Parameters to be Monitored | Location | Time/Frequency/Duration | Method of Measurements | Performance Standard / Quantitative Targets | Responsibilities | | | Equipment and Monitoring Cost (Million BDT) |
| | | | | | PIU | PIAC | Contractor | |
| | | | that drinking water meeting national standards is being imported for workers consumption. | | | | | |

Om

Dr.

Upgradation of 9 Existing AIS Substations

Upgradation of 9 Existing AIS Substations

| Environmental Parameters to be Monitored | Location | Time/Frequency/Duration | Method of Measurements | Performance Standard / Quantitative Targets | Responsibilities | | | Equipment and Monitoring Cost (Million BDT) |
|---|---|--|--|--|--|--|--|--|
| | | | | | PIU | PIAC | Contractor | |
| Detailed Design and Pre-Construction Phase | | | | | | | | |
| Ecology | Substation sites areas used | Once prior to construction – baseline monitoring prior to the start of any activity onsite | Ecological survey of substation site areas used to include presence flora and fauna and tree enumeration (numbers, species, size etc.) | No net loss of biodiversity following construction. Only types of habitats and number of trees documented in IEE are lost, any trees lost are compensated for, 1:3 replacement with native tree species in suitable alternative location, 100% survival rate. No damage to other habitats/trees/vegetation outside the substation. | PIU to ensure survey undertaken by contractor report in EMR to ADB | PIAC to supervise survey in the field and support PIU in checking compliance | Contractor to undertake survey and report to PIU | <ul style="list-style-type: none"> - Ecological survey by qualified and experienced Environmentalists - Part of contract cost, include costs if implementing EMP as BOQ line. |
| Air Quality: PM ₁₀ , PM _{2.5} , SO _x and NO _x O ₃ CO and Pb per the National Air Pollution (Control) Rules 2022 (9 locations). | Nearest sensitive receptor within 500 m of substations on each boundary | Once prior to construction – baseline monitoring prior to the start of any activity onsite | To be measured as 1-hour, 8-hour and 24-hour averages along with meteorological data- temperature humidity, wind speed, and wind direction-during the dry season as per National Air Pollution (Control) Rules 2022. | Compliance with ambient air quality standards to be applied to the project (see Annex 3– Applicable Standards for EMP) or no increase above baseline if already exceeded | PIU to ensure monitoring undertaken by contractor report in EMR to ADB | PIAC to support PIU in recruitment ensuring that air quality monitoring is carried out | Contractor to undertake measurements and report to PIU | <ul style="list-style-type: none"> - Professional, calibrated, portable outdoor air quality monitoring sensors to be used. - Part of contract cost, include costs of implementing EMoP as BOQ line |

Upgradation of 9 Existing AIS Substations

| Environmental Parameters to be Monitored | Location | Time/Frequency/Duration | Method of Measurements | Performance Standard / Quantitative Targets | Responsibilities | | | Equipment and Monitoring Cost (Million BDT) |
|--|--|--|--|---|--|--|--|---|
| | | | | | PIU | PIAC | Contractor | |
| | | | - Record details as required by the National Air Pollution (Control) Rules 2022 | | | | | |
| Noise level: dB(A) (9 locations). | Site boundary and nearest sensitive receptor within 500m of substations on each boundary. | Once prior to construction – baseline monitoring prior to the start of any activity onsite | 1hr LAeq and LAnight over a 48-hour period including workday and weekend using professional, calibrated portable monitoring devices. Noise levels to be measured outdoors in free field conditions. Record details as required by the National Noise Pollution (Control) Rules 2006. | Compliance with ambient noise standards to be applied to the project (see Annex 3– Applicable Standards for EMP) or <3dBA increase above baseline if already exceeded | PIU to ensure monitoring undertaken by contractor and report in EMR to ADB | PIAC to supervise measurements in the field and support PIU in checking compliance | Contractor to undertake measurements and report to PIU | - Portable, professional, real-time calibrated Type 1 or 2 sound level meter meeting all appropriate IEC standards to be used with a tripod. - Part of contract cost, include costs of implementing EMoP as BOQ line |
| Water quality: Surface water (pH, DO, BOD ₅ , COD, TDS, TSS, NH ₃ -N, PO ₄ , Turbidity, | Nearest surface waterbodies and groundwater sources (wells) unless >500m distant from the substations: | Once prior to construction – baseline monitoring prior to the start of any activity onsite | - Water sample is to be taken in a clean, non-contaminated, well-sealed container and | No pollution incident affecting surface or groundwater quality and compliance with ambient water quality standards to be applied to the project | - ensure monitoring undertaken by contractor and | PIAC to supervise measurements in the field and support PIU in | Contractor to undertake measurements and report to PIU | - Water quality tests by accredited laboratory. - Part of contract cost, include |

Upgradation of 9 Existing AIS Substations

| Environmental Parameters to be Monitored | Location | Time/Frequency/Duration | Method of Measurements | Performance Standard / Quantitative Targets | Responsibilities | | | Equipment and Monitoring Cost (Million BDT) |
|--|--|---|--|---|--|--|--|---|
| | | | | | PIU | PIAC | Contractor | |
| Chloride, Total Coliform (TC), Faecal Coliform (FC), Oil & Grease, PCBs (if used by community as source of drinking water also test against GOB drinking water parameters (full suite) | | | tested in-situ or within the next 48h for those that do not degrade or suit rapid testing. Water quality tests by accredited laboratory (physical, chemical, and bacteriological tests) –Record details as required by the ECR, 2023 | (see Annex 3– Applicable Standards for EMP) or no increase above baseline if already exceeded. | to report in EMR to ADB | checking compliance | | costs of implementing EMoP as BOQ line |
| PCBs | Substation equipment [transformers] to be demolished or removed, all defunct transformers stored in yard that contain oil at existing substation where not already | One time for baseline establishment prior to the start of any demolition works/site clearance, no additional impact from project as all new equipment and oil procured will be PCB-free | Testing of transformer oil by accredited laboratory to follow UNIDO Guideline for PCB-testing | All existing transformers are PCB-free. If present this is to be treated as an unanticipated impact and PCB remedial action plan developed and implemented by the PIU prior to removal of the defunct transformers to the NESCO stores. | ensure monitoring undertaken by contractor and to report in EMR to ADB | PIAC to supervise measurements in the field and support PIU in checking compliance | Contractor to undertake measurements and report to PIU | existing substation for bay extension – Part of contract cost, include costs of implementing EMoP as BOQ line |

Upgradation of 9 Existing AIS Substations

| Environmental Parameters to be Monitored | Location | Time/Frequency/Durati on | Method of Measurements | Performance Standard / Quantitative Targets | Responsibilities | | | Equipment and Monitoring Cost (Million BDT) |
|---|--|---|---|---|--|---|--|--|
| | | | | | PIU | PIAC | Contractor | |
| | tested under DOE regime | | | | | | | |
| Asbestos | A total of 7 old residential/buildings and other equipment to be demolished by NESCO | One time for baseline establishment prior to the start of any demolition works. | Licensed entity to survey and test for the presence of ACMs in electrical equipment and buildings to be demolished. | <ul style="list-style-type: none"> No asbestos was present prior to demolition work. If present this is to be treated as an unanticipated impact and asbestos remedial action plan developed and implemented by the PIU or third parties prior to demolition. Demolition of any electrical equipment and buildings containing ACMs follow national laws and regulations, and international good practice such as ADB's Good Practice Guidance on the Use of Asbestos. No workers and communities affected by exposure to ACMs. | ensure monitoring undertaken by contractor and testing at substation sites prior to their demolition, obtain and report results of surveys in EMR to ADB | PIAC to support PIU in supervision of contractor ensuring that asbestos survey and testing is carried out | Contractor to undertake measurements and report to PIU | Part of contract cost, include costs of implementing EMoP as BOQ line |
| Soil quality pH, Texture Organic Contents, Lead (Pb), Copper (Cu), | For existing substation sites with oil spillage present | One time for baseline establishment prior to the start of any activity onsite | Soil samples to be taken from across the substation area at various locations at surface and at | No soil contamination was present prior to construction work. If present this is to be treated as an | ensure monitoring undertaken by contractor and | PIAC to supervise measurements in the field and support PIU in | Contractor to undertake measurements and report to PIU | Soil quality tests by accredited laboratory. Part of contract cost, include |

Upgradation of 9 Existing AIS Substations

| Environmental Parameters to be Monitored | Location | Time/Frequency/Duration | Method of Measurements | Performance Standard / Quantitative Targets | Responsibilities | | | Equipment and Monitoring Cost (Million BDT) |
|---|----------|-------------------------|---|---|-------------------------|---------------------|------------|---|
| | | | | | PIU | PIAC | Contractor | |
| Chromium (Cr), Cadmium (Cd), Polychlorinated Biphenyls (PCBs) | | | depth in clean, non-contaminated, well-sealed containers and tested within the next 48h following international good practice for contaminated land investigation. ¹⁵ Soil quality tests by accredited laboratory to include pH, Texture Organic Contents, Lead (Pb), Copper (Cu), Chromium (Cr), Cadmium (Cd), Polychlorinated Biphenyls (PCBs) and any other contaminants indicated by | unanticipated impact and contaminated land remedial action plan developed and implemented by the contractor before the start of any other on-site activity. No pollution incident affecting soil quality and compliance with soil quality standards to be applied to the project e.g., international good practice guidelines. ¹⁶ | to report in EMR to ADB | checking compliance | | costs if implementing EMP as BOQ line. |

Upgradation of 9 Existing AIS Substations

| Environmental Parameters to be Monitored | Location | Time/Frequency/Duration | Method of Measurements | Performance Standard / Quantitative Targets | Responsibilities | | | Equipment and Monitoring Cost (Million BDT) |
|---|---|---|--|---|---|--|--|---|
| | | | | | PIU | PIAC | Contractor | |
| | | | contaminated land professional | | | | | |
| Health and Safety: operational drinking water supplies | All sources that will be developed by contractor for use as an operational drinking water supply | One time for baseline establishment prior to the start of any activity onsite | Water sample is to be taken in a clean, non-contaminated, well- sealed container and tested within the next 48h. Drinking water quality tests against Bangladesh drinking water standards [physical, bacteriological, chemical including arsenic] by accredited laboratory, per Annex 3. | Drinking water provided for operational substations meets national drinking water standards or appropriate level of water treatment is incorporated into the project design | PIU to ensure monitoring undertaken by contractor and to report in EMR to ADB | PIAC to supervise measurements in the field and support PIU in checking compliance | Contractor to undertake measurements and report to PIU | Water quality tests by accredited laboratory. Part of contract cost, include costs of implementing EMoP as BOQ line |
| Health and safety/physical cultural resources: condition surveys in relation to property damage from construction | All substations; include surveys of all properties located immediately adjacent all boundaries (including informal settlements) at substations for which demolition and/or piling | One time for baseline establishment prior to the start of any activity onsite | Photographic and/or structural precondition surveys of existing property condition including utilities, structures, drains etc. Risk assessment of | Damages to property avoided but if caused, to be paid for by the contractor. National Building Code to be referred to in relation to ensuring structural safety of property during works. | PIU to ensure surveys undertaken by contractor and to report in EMR to ADB | PIAC to supervise surveys in the field and support PIU in checking compliance | Contractor to undertake surveys and report to PIU | Part of construction cost, include costs of implementing EMP as BOQ line. |

Upgradation of 9 Existing AIS Substations

| Environmental Parameters to be Monitored | Location | Time/Frequency/Duration | Method of Measurements | Performance Standard / Quantitative Targets | Responsibilities | | | Equipment and Monitoring Cost (Million BDT) |
|--|-----------------------------|--|---|---|--|---|---|---|
| | | | | | PIU | PIAC | Contractor | |
| | works are being required | | potential damage to structures and additional recommendations for structural and vibration monitoring condition where there is a risk of property damage | | | | | |
| Construction Phase | | | | | | | | |
| Ecology | Substation sites areas used | Ongoing throughout construction, monthly reporting of records kept by the contractor. Ecological survey once on commissioning and prior to handover of substation to NESCO | Ecological survey of substation site areas used to include presence flora and fauna and tree enumeration (numbers, species, size etc.) Keep records of all | No net loss of biodiversity following construction. Only types of habitats and number of trees documented in IEE are lost, including minimum number of trees, any trees lost are compensated for, 1:3 replacement with native tree species in suitable alternative location, 100% survival rate. No damage to other habitats/trees/vegetation outside the substation. | PIU to ensure record keeping by contractor and to report in EMR to ADB | PIAC to supervise contractor and support PIU in checking compliance | Contractor to undertake surveys, keep records and report to PIU in monthly progress reports | Ecological survey by qualified and experienced Environmentalists Part of contract cost, include costs of implementing EMoP as BOQ line |

Upgradation of 9 Existing AIS Substations

| Environmental Parameters to be Monitored | Location | Time/Frequency/Duration | Method of Measurements | Performance Standard / Quantitative Targets | Responsibilities | | | Equipment and Monitoring Cost (Million BDT) |
|---|--|---|---|---|---|--|--|--|
| | | | | | PIU | PIAC | Contractor | |
| | | | compensatory tree plantation undertaken (numbers, species, size etc.) including survival and replacement of trees during defect liability period | | | | | |
| Air Quality: PM ₁₀ , PM _{2.5} , NO ₂ , SO ₂ , O ₃ CO and Pb per the National Air Pollution (Control) Rules 2022. A total of 9 sample locations. | Nearest sensitive receptor within 500 m of substations on each boundary Additional locations at request of PIU/PIAC in the event of visible dust pollution or grievance received during construction. | Quarterly during active construction involving demolition and earthworks, and then as requested by PIU/PIAC in event of visible dust pollution or grievance received during construction. | To be measured as 1-hour, 8 hour and 24-hour averages along with meteorological data-temperature humidity, wind speed, and wind direction-during the dry season as per National Air Pollution (Control) Rules 2022. Record details as required by the National Air | No exceedance of ambient air quality standards (see Annex 3–Applicable Standards for EMP) or no worsening if already exceeded (as per the baseline) | PIU to ensure monitoring undertaken by contractor and to report in EMR to ADB | PIAC to supervise measurements in the field and support PIU in checking compliance | Contractor to undertake measurements and report to PIU | Professional, calibrated, portable outdoor air quality monitoring sensors to be used. Part of contract cost, include costs of implementing EMoP as BOQ line |

Upgradation of 9 Existing AIS Substations

| Environmental Parameters to be Monitored | Location | Time/Frequency/Duration | Method of Measurements | Performance Standard / Quantitative Targets | Responsibilities | | | Equipment and Monitoring Cost (Million BDT) |
|---|---|---|---|--|---|--|--|--|
| | | | | | PIU | PIAC | Contractor | |
| | | | Pollution (Control) Rules 2022 and ECR, 2023 | | | | | |
| Noise level: dB(A) – 9 samples from different sites. | Site boundary and nearest sensitive receptor within 500 m of substations on each boundary. Additional locations at request of PIU/PIAC in the event of noise pollution concerns or grievance received during construction | Monthly during active demolition and construction involving noisy activities, and then as requested by PIU/PIAC in event of noise pollution concerns or grievance received during construction. Once on commissioning and prior to handover of substation to NESCO to confirm operational substation meets noise standards. | 1hr LAeq and Laday and LAnight over a 48-hour period including workday and weekend using professional, calibrated portable monitoring devices. Noise levels to be measured outdoors in free field conditions. Record details as required by the National Noise Pollution (Control) Rules 2006 | No exceedance of ambient noise standards (see Annex 3– Applicable Standards for EMP) or <3dBA increase if already exceeded (as per the baseline) | PIU to ensure monitoring undertaken by contractor and to report in EMR to ADB | PIAC to supervise measurements in the field and support PIU in checking compliance | Contractor to undertake measurements and report to PIU | Portable, professional, real-time calibrated Type 1 or 2 sound level meter meeting all appropriate IEC standards to be used with a tripod. Part of contract cost, include costs of implementing EMoP as BOQ line |
| Water quality: Surface Water Quality: pH, DO, BOD ₅ , COD, TDS, TSS, NH ₃ - | Nearest surface waterbodies and groundwater sources (wells) unless > 500m | Quarterly during active construction involving earthworks, and then only required if requested by PIU/PIAC in event of | Water sample is to be taken in a clean, non-contaminated, well- sealed | No pollution incident affecting surface or groundwater quality and compliance with ambient water quality standards to | PIU to ensure monitoring undertaken by contractor and | PIAC to supervise measurements in the field and support | Contractor to undertake measurements and report to PIU | Water quality tests by accredited laboratory. |

Upgradation of 9 Existing AIS Substations

| Environmental Parameters to be Monitored | Location | Time/Frequency/Duration | Method of Measurements | Performance Standard / Quantitative Targets | Responsibilities | | | Equipment and Monitoring Cost (Million BDT) |
|---|---|--|--|--|--|---|--|---|
| | | | | | PIU | PIAC | Contractor | |
| N, PO ₄ , Turbidity, Chloride, Fecal Coliform (FC), Total Coliform (TC), Oil and Grease, PCBs Ground Water/Drinking Water Quality: pH, Pb, Mn, Fe, As, EC, Cl, Total Coliform (TC), Fecal Coliform (FC), Turbidity, Odor, PCBs If used by local community as a source of drinking water to also test against GOB drinking water standards (full suite) | distant from the substation. Additional locations at request of PIU/PIAC in the event of water pollution concerns or grievance received during construction: | water pollution concerns or grievance received during construction. During land development/infill and piling works adjacent to waterbodies using handheld meter for pH, turbidity, TDS, TSS and DO | container and tested in-situ or within the next 48h for those that do not degrade or suit rapid testing. Water quality tests by accredited laboratory (physical, chemical, and bacteriological tests). If used as source of drinking water to also test against Bangladesh drinking water standards per Annex 3. Record details as required by the ECR, 2023 | be applied to the project (see Annex 3– Applicable Standards for EMP) or no increase above baseline if already exceeded. | to report in EMR to ADB | PIU in checking compliance | | Part of contract cost, include costs of implementing EMoP as BOQ line |
| Water resources | All substation sites, including construction camp | Ongoing throughout construction, monthly reporting of records kept by the contractor | Water volume used and source (construction and drinking water). | No grievance received during construction or operation regarding conflict with other water users | PIU to ensure record keeping by contractor and to report in EMR to ADB | PIAC to supervise contractor and support PIU in checking compliance | Contractor to keep records and report to PIU in monthly progress reports | Part of contract cost, include costs of implementing EMoP as BOQ line |

Upgradation of 9 Existing AIS Substations

| Environmental Parameters to be Monitored | Location | Time/Frequency/Duration | Method of Measurements | Performance Standard / Quantitative Targets | Responsibilities | | | Equipment and Monitoring Cost (Million BDT) |
|--|---|---|---|---|---|--|--|---|
| | | | | | PIU | PIAC | Contractor | |
| Soil | All substation sites with earthworks/cut and fill, and piling works | Ongoing throughout construction, monthly reporting of records kept by the contractor | Keep records of earthworks involved, including total volume in m3 of soil excavated and reused (any disposed of as spoil off site to licensed waste disposal facilities recorded as per waste generation) | Earthworks documented, and all excavated and cut and fill volumes accounted for, either reused on-site or disposed of off-site to licensed waste disposal facilities | PIU to ensure record keeping by contractor and to report in EMR to ADB | PIAC to supervise contractor and support PIU in checking compliance | Contractor to keep records and report to PIU in monthly progress reports | Part of contract cost, include costs of implementing EMoP as BOQ line |
| Effluent | All substation sites, including construction camp | Monthly testing of all effluent streams from SS | Monitor all effluent discharges from septic tank/soakaway as per GoB effluent standards or the general IFC EHS effluent guidelines whichever is more stringent. | Effluent standards met and no grievance received during construction or operation regarding water pollution | PIU to ensure record keeping by contractor and to report in EMR to ADB | PIAC to supervise contractor and support PIU in checking compliance | Contractor to keep records and report to PIU in monthly progress reports | Part of contract cost, include costs of implementing EMoP as BOQ line |
| Health and Safety: operational drinking water supplies | All sources that will be developed for use as an operational drinking water supply as part of substation construction (pre- and post- | Once on commissioning and prior to handover of substation to NESCO to confirm operational substation meets drinking water quality standards | Water sample is to be taken in a clean, non-contaminated, well- sealed container and tested within the next 48h. Drinking water quality tests | Drinking water provided for operational substations meets national drinking water standards or appropriate level of water treatment is incorporated into the project design | PIU to ensure monitoring undertaken by contractor and to report in EMR to ADB | PIAC to supervise measurements in the field and support PIU in checking compliance | Contractor to undertake measurements and report to PIU | Water quality tests by accredited laboratory. Part of contract cost, include costs of |

Upgradation of 9 Existing AIS Substations

| Environmental Parameters to be Monitored | Location | Time/Frequency/Duration | Method of Measurements | Performance Standard / Quantitative Targets | Responsibilities | | | Equipment and Monitoring Cost (Million BDT) |
|---|---|---|---|--|---|--|--|---|
| | | | | | PIU | PIAC | Contractor | |
| | treatment samples are to be taken) | | against Bangladesh drinking water standards by accredited laboratory (physical, bacteriological and chemical), per Annex 3. Record details as required by the ECR, 2023 | | | | | implementing EMoP as BOQ line |
| Health and safety: electromagnetic field (EMF) | All substation sites | Substation boundary and adjacent to electrical equipment Once on commissioning and prior to handover of substation to NESCO to confirm operational substation meets EMF reference levels | EMF levels to be monitored using professional, calibrated portable monitoring devices | No exceedance of ICNIRP reference levels | PIU to ensure monitoring undertaken by contractor and to report in EMR to ADB | PIAC to supervise measurements in the field and support PIU in checking compliance | Contractor to undertake measurements and report to PIU | Portable but professional, calibrated EMF detector Part of contract cost, include costs of implementing EMoP as BOQ line |
| Health and safety/physical cultural resources: condition surveys in relation to property damage | Substations with adjacent properties at risk (ongoing survey of properties flagged at risk during pre-construction) | Ongoing throughout construction, daily site checks and additional monitoring of condition as per the recommendation of the pre-construction surveys | Ongoing photographic and/or structural condition surveys of existing property condition including utilities, | Damages to property avoided but if caused, to be paid for by the contractor. National Building Code to be referred to in relation to ensuring | PIU to ensure monitoring undertaken by contractor and to report in EMR to ADB | PIAC to supervise measurements in the field and support PIU in checking compliance | Contractor to undertake measurements and report to PIU | Part of contract cost, include costs of implementing EMoP as BOQ line |

Upgradation of 9 Existing AIS Substations

| Environmental Parameters to be Monitored | Location | Time/Frequency/Duration | Method of Measurements | Performance Standard / Quantitative Targets | Responsibilities | | | Equipment and Monitoring Cost (Million BDT) |
|--|--|--|--|---|---|------|--|---|
| | | | | | PIU | PIAC | Contractor | |
| | | Once on commissioning and prior to handover of substation to NESCO to confirm no residual damage occurred | structures, drains etc. Structural condition monitoring of properties at risk as recommended during the pre-construction surveys | structural safety of property during works. | | | | |
| Operation and Maintenance | | | | | | | | |
| Noise in dB(A) | Site boundary and nearest receptor to the substation | Semi-annually or as may be required by DOE during O&M (monitoring can cease if compliance demonstrated at end of first year) | 1hr LAq over a 48-hour period including workday and weekend using professional, calibrated portable monitoring devices. Record details as required by the ECR, 2023 | No exceedance of noise standards specified in Annex 3 (or less than 3dBA increase if already exceeded) at site boundary and sensitive receptors | NESCO ESSU (supported by third party if needed) to undertake monitoring and report to ADB | NA | Contractor to supply monitoring equipment for use by NESCO ESSU during O&M | 1no. portable, professional, real-time calibrated Type 1 or 2 sound level meter meeting all appropriate IEC standards to be used with a tripod to be provided for ESSU by the contractor / include for equipment provision as a BOQ line NESCO O&M budget |

Upgradation of 9 Existing AIS Substations

| Environmental Parameters to be Monitored | Location | Time/Frequency/Duration | Method of Measurements | Performance Standard / Quantitative Targets | Responsibilities | | | Equipment and Monitoring Cost (Million BDT) |
|---|---|---|---|---|---|------|------------|--|
| | | | | | PIU | PIAC | Contractor | |
| Wastewater discharge; pH, BOD5, COD, TDS, TSS, DO, NH3-N, PO4, Turbidity, Odor, Chloride, Total Coliform (TC), Ammonia-Nitrogen, Oil & Grease, Polychlorinated Biphenyls (PCBs) | All substations not connected to sewerage system e.g. having septic tank with soak away | Semi-annually or as may be required by DOE during O&M | Treated water sample is to be taken in a clean, non-contaminated, well- sealed container and tested within the next 48h. Water quality tests against Bangladesh surface water quality standards by accredited laboratory (physical, chemical, and bacteriological tests) Record details as required by the ECR, 2023 | No pollution incident affecting surface or groundwater quality and compliance with effluent discharge standards to be applied to the project (see Annex 3– Applicable Standards for EMP) or no increase above baseline if already exceeded. | NESCO ESSU to appoint third-party laboratory to undertake monthly testing and report the results to ADB | NA | NA | Water quality tests by accredited laboratory. NESCO O&M budget |
| Health and safety: drinking water supplies | All substations- | Monthly testing or reporting of records kept | Water sample is to be taken in a clean, non-contaminated, well- sealed | Drinking water provided for operational substations meets national drinking water standards or appropriate level of water | Substation manager to keep records and report to ESSU in monthly | NA | NA | Water quality tests by accredited laboratory. |

Upgradation of 9 Existing AIS Substations

| Environmental Parameters to be Monitored | Location | Time/Frequency/Durati on | Method of Measurements | Performance Standard / Quantitative Targets | Responsibilities | | | Equipment and Monitoring Cost (Million BDT) |
|--|----------|--------------------------|--|---|---|------|------------|---|
| | | | | | PIU | PIAC | Contractor | |
| | | | container and tested within the next 48h. Drinking water quality tests against Bangladesh drinking water standards by accredited laboratory (physical, chemical, and bacteriological tests including arsenic levels) where a surface or groundwater drinking water supply was provided by the contractor or sources where supplier is unable to provide water quality test results. Alternatively, documentary evidence that | treatment is being maintained | progress reports NESCO ESSU to appoint third-party laboratory to undertake monthly testing and report the results to ADB | | | NESCO O&M budget |

Upgradation of 9 Existing AIS Substations

| Environmental Parameters to be Monitored | Location | Time/Frequency/Durati on | Method of Measurements | Performance Standard / Quantitative Targets | Responsibilities | | | Equipment and Monitoring Cost (Million BDT) |
|--|----------------------|---|---|--|---|------|--|--|
| | | | | | PIU | PIAC | Contractor | |
| | | | drinking water meeting national standards is being imported for O&M workers consumption. Record details as required by the ECR, 2023 | | | | | |
| Health and safety: Electromagnetic field (EMF) | All substation sites | Semi-annually Routine checks and record keeping during O&M for workers in close contact with EMF | EMF levels to be monitored using professional, calibrated portable monitoring devices Continuous checks for substation workers in close contact with EMF through use of personal EMF monitor carried by workers at all times while working on or near live | No exceedance of ICNIRP reference levels and records of EMF checking | NESCO substation manager (supported by third party if needed) to undertake monitoring and report monthly to the ESSU NESCO ESSU to report to ADB | NA | Contractor to supply monitoring equipment for use by NESCO substation manager and staff during O&M | Portable but professional, calibrated EMF detector, to be provided by the contractor one per substation along with personal EMF radiation exposure monitoring equipment for substation workers / include for equipment provision as a BOQ line NESCO O&M budget |

Upgradation of 9 Existing AIS Substations

| Environmental Parameters to be Monitored | Location | Time/Frequency/Durati on | Method of Measurements | Performance Standard / Quantitative Targets | Responsibilities | | | Equipment and Monitoring Cost (Million BDT) | |
|--|-----------------|--|--|--|--|------|------------|---|-----|
| | | | | | PIU | PIAC | Contractor | | |
| | | | electrical equipment | | | | | | |
| Hazardous materials– incidents | All substations | Daily checks for pollution incidents and record keeping during O&M | <ul style="list-style-type: none"> - Records of pollution incidents (e.g., type of material spilled, amount in kg or m3 and action taken to clean up) - Carry out visual inspection and interviews with workers and the community to identify if any unrecorded incidents occurred | <ul style="list-style-type: none"> - No pollution incident affecting soil of water quality - zero major incidents occurred. - Minor incidents responded to in accordance with O&M response plan procedures with lessons learnt for future if they occur. | <ul style="list-style-type: none"> - Substation manager to keep records and report to ESSU in monthly progress reports - Any pollution incident to be reported within 24 hours to ESSU by substation/line manager - NESCO ESSU to report to ADB | NA | NA | NESCO budget | O&M |
| Health and safety: accident records | All substations | Daily checks and record keeping during O&M | Keep records of health and safety incidents, compile records from substations and carry out interviews with workers and the community to identify if any unrecorded | <ul style="list-style-type: none"> - Zero lost time incidents or fatalities (among workers and community) - All near miss, minor, lost time, and fatal incidents as well as suspected/confirmed STD/AIDS/communicable disease instances having adequate response plan, with lessons learnt for future if they occur. | <ul style="list-style-type: none"> - Substation/line manager to keep records and report to ESSU in monthly progress reports - Any lost time incident or fatality to be reported within 24 hours to | NA | NA | NESCO budget | O&M |

Upgradation of 9 Existing AIS Substations

| Environmental Parameters to be Monitored | Location | Time/Frequency/Durati on | Method of Measurements | Performance Standard / Quantitative Targets | Responsibilities | | | Equipment and Monitoring Cost (Million BDT) |
|--|----------|--------------------------|------------------------|---|---|------|------------|---|
| | | | | | PIU | PIAC | Contractor | |
| | | | incidents occurred | | ESSU by substation/line manager - NESCO ESSU to report to ADB - Any lost time incident or fatality to be reported within 24 hours to ADB | | | |

Om

Dr.

Annex 3. Applicable Standards for EMP

Table 3.1: Applicable Ambient Air Quality Standards

| Parameter | Bangladesh Ambient Air Quality Standard (ECR 2023) ($\mu\text{g}/\text{m}^3$) ^a | WHO Air Quality Guidelines($\mu\text{g}/\text{m}^3$) | | Applicable to the Project per ADB Safeguard Policy Statement ^d ($\mu\text{g}/\text{m}^3$) |
|-------------------------|--|--|--|--|
| | | Global Update ^b 2005 | Global Update ^c 2021 | |
| PM ₁₀ | 50 (1-year) 150 (24-h) | 20 (1-year) 50 (24-h) | 15 (1-year) 45 (24-h) | 45 (24-h) |
| PM _{2.5} | 35 (1-year) 65 (24-h) | 10 (1-year) 25 (24-h) | 5 (1-year) 15 (24-h) | 15 (24-h) |
| SO ₂ | 250 (1-h) 80 (24-h) | 20 (24-h) 500 (10-min) | 40 (24-h) | 40 (24-h) 500 (10-min) |
| NO ₂ | 40 (1-year) 80 (24-hr) 100 (1-h) | 40 (1-year) 200 (1-h) | 10 (1-year) 25 (24-h) | 25 (24-h) 200 (1-h) |
| CO | 5,000 (8-h) 20,000 (1-h) | - | 4,000 (24-h) | 4,000 (24-h) 10,000 (8-h) 40,000 (1-h) |
| Lead | 0.25 (1-year) 0.50 (24-h) | - | - | 0.5 (1-year) |
| Ozone (O ₃) | 180 (1-h) 100 (8-h) | 100 (8-h) | 100 (8-h) 60 (peak season, average 6 months) | 100 (8-h) |

ADB = Asian Development Bank, CO = Carbon Monoxide, H = Hour, $\mu\text{g}/\text{M}^3$ = Microgram Per Cubic Meter, Min = Minute, NO₂ = Nitrogen Dioxide, PM_{2.5} = Particulate Matter 2.5 Microns, PM₁₀ = Particulate Matter 10 Microns, SO₂ = Sulfur Dioxide, TSP = Total Suspended Particle, WHO = World Health Organization.

a/ SRO NO. 255-LAW/2022(Bangladesh Air Pollution Control Rules, 2022).
<https://mccibd.org/wpcontent/uploads/2022/07/Air-Pollution-Control-Rules-2022.pdf>

b/ IFC World Bank Group. 2007. *Environmental, Health and Safety General Guidelines*. Washington, D.C.

c/ WHO. 2021. *WHO global air quality guidelines: particulate matter (PM_{2.5} and PM₁₀), ozone, nitrogen dioxide, sulfur dioxide and carbon monoxide*. Geneva. 24-h standards are 99%iles.

d/ If less stringent levels or measures are appropriate in view of specific project circumstances, executing agency will provide full and detailed justification for any proposed alternatives that are consistent with the requirements presented in ADB SPS within the disclosed IEE.

Table 3.2: Applicable Noise Quality Standards

| Sl | Category of areas | The Noise Pollution (Control) Rules 2006 (dBA) | | IFC Standard, 2007 (One Hour LA _{eq} dBA) ^a | | Applicable to the Project per ADB Safeguard Policy Statement (dBA) ^b | |
|----|--|--|-------|---|--|--|-------|
| | | Day | Night | Day (07:00-22:00) | Night (22:00-07:00) | Day | Night |
| 1 | Silent Zone ^c | 50 | 40 | - | - | 50 | 40 |
| | Residential Zone | 55 | 45 | 55 | 45 | 55 | 45 |
| 3 | Mixed zone (mainly residential area, simultaneously used for commercial and industrial purposes) | 60 | 50 | - | - | 60 | 50 |
| 4 | Commercial Zone | 70 | 60 | 70 | 70 | 70 | 60 |
| | Industrial Zone | 75 | 70 | 70 | 70 | 70 | 70 |
| 6 | Occupational Health and Safety (above these limits PPE to be worn) | TBC | | | 8 dB(A) (LA _{eq} 8 hours) Peak sound pressure 140 dB(C) LA _{max} 110 dB(A) | 8 dB(A) (LA _{eq} 8 hours) Peak sound pressure 140 dB(C) Average maximum 110 dB(A) | |

Source: Bangladesh Noise Pollution Control Rules 2006, Guidelines for Community Noise, World Health Organization (WHO), 1999 and IFC World Bank Group. 2007. Environmental, Health and Safety General Guidelines. Washington, D.C.

a/ Except for occupational health and safety levels guidelines values are for noise levels measured out of doors. Noise monitoring should be carried out using a Type 1 or sound level meter meeting all appropriate IEC standards.

b/ If less stringent levels or measures are appropriate in view of specific project circumstances, executing agency will provide full and detailed justification for any proposed alternatives that are consistent with the requirements presented in ADB SPS within the disclosed IEE report.

c/ Area up to a radius of 100 meters around hospitals or educational institutions or special institutions/establishments identified/to be identified by the Government is designated as Silent Zones where use of horns of vehicles or other audio signals, and loudspeakers are prohibited.

d/ In a mixed zone individual residential receptors must achieve the residential zone level as the IFC standard is receptor not area based

e/ In a commercial or industrial zone any individual residential receptors must achieve the residential zone level as the IFC standard is receptor not area based

Table 3.3: Applicable Drinking Water Quality Standards (Groundwater Quality)

| Sl | Parameter | Unit Standard | Bangladesh Standard (ECR 2023) | WHO Guidelines 2017 |
|----|------------------------------------|---------------|--------------------------------|---------------------|
| 1 | Aluminum | mg/l | 0.2 | 0.2 |
| 2 | Ammonia (NH ₃) | mg/l | 1.5 | - |
| 3 | Arsenic | mg/l | 0.05 | 0.01 |
| 4 | Barium | mg/l | 0.7 | 1.3 |
| 5 | Benzene | mg/l | 0.01 | 0.01 |
| 6 | Boron | mg/l | 1 | 2.4 |
| 7 | Cadmium | mg/l | 0.003 | 0.003 |
| 8 | Calcium | mg/l | 75 | - |
| 9 | Chloride | mg/l | 250* | - |
| 10 | Carbon Tetrachloride | mg/l | 0.005 | 0.004 |
| 11 | 1.1 Dichloroethylene | mg/l | 0.03 | |
| 12 | 1.2 Dichloroethylene | mg/l | 0.03 | 0.03 |
| 13 | Tetrachloroethylene | mg/l | 0.04 | 0.04 |
| 14 | Trichloroethylene | mg/l | 0.02 | 0.02 |
| 15 | Pentachlorophenol | mg/l | 0.009 | 0.009 |
| 16 | 2.4.6 Trichlorophenol | mg/l | 0.02 | 0.2 |
| 17 | Chlorine (Residual) | mg/l | 0.2 | 0.2 |
| 18 | Chloroform | mg/l | 0.09 | 0.3 |
| 19 | Chromium (total) | mg/l | 0.05 | 0.05 |
| 20 | Coliform (fecal) | cfu/100 ml | 0 | - |
| 21 | Coliform (total) | cfu/100 ml | 0 | - |
| 22 | Color | Huyghens Unit | 15 | - |
| 23 | Copper | mg/l | 1.5 | 2 |
| 24 | Cyanide | mg/l | 0.05 | - |
| 25 | Fluoride | mg/l | 1.0 | 1.5 |
| 26 | Hardness (as CaCO ₃) | mg/l | 500 | - |
| 27 | Iron (Fe) | mg/l | 0.3-1.0 | - |
| 28 | Nitrogen (Total Kjeldahl Nitrogen) | mg/l | 1 | - |
| 29 | Lead | mg/l | 0.01 | 0.01 |
| 30 | Magnesium | mg/l | 30-35 | - |
| 31 | Manganese | mg/l | 0.4 | 0.4 |
| 32 | Mercury | mg/l | 0.001 | 0.006 |
| 33 | Nickel | mg/l | 0.05 | 0.07 |
| 34 | Nitrate | mg/l | 45 | 50 |
| 35 | Nitrite | mg/l | 1 | 3 |

| Sl | Parameter | Unit Standard | Bangladesh Standard (ECR 2023) | WHO Guidelines 2017 |
|----|--|---------------|--------------------------------|---------------------|
| 36 | Odor | | Odorless | - |
| 37 | Oil & Grease | mg/l | 0.01 | - |
| 38 | pH | | 6.5-8.5 | - |
| 39 | Phenolic Compounds | mg/l | 0.002 | - |
| 40 | Potassium | mg/l | 12 | - |
| 41 | Radioactive Materials (gross alpha activity) | bq/l | 0.1 | - |
| 42 | Radioactive Materials (gross beta activity) | bq/l | 1.0 | - |
| 43 | Selenium | mg/l | 0.01 | 0.04 |
| 44 | Silver | mg/l | 0.02 | - |
| 45 | Sodium | mg/l | 200 | 50 |
| 46 | Suspended particulate matters | mg/l | 10 | - |
| 47 | Sulfide as H ₂ S | mg/l | 0.05 | - |
| 48 | Sulfate | mg/l | 250 | - |
| 49 | Total dissolved solids | mg/l | 1000 | 1000 |
| 50 | Temperature | °C | 20-30 | - |
| 51 | Tin | mg/l | 2 | - |
| 52 | Turbidity | NTU | 5 | - |
| 53 | Zinc | mg/l | 5 | - |
| 54 | Aldrin/Dieldrin | Microgram/l | 0.003 | |
| 55 | Anionic Detergents | mg/l | 0.2 | |

Table 3.4: Applicable Effluent Discharge Standards by Receiving Environment

| SI | Parameters | Unit | Discharge To ^a | | | IFC Standard 2007, Treated Sanitary Sewage Discharge to Inland Surface Water |
|----|--|--|---------------------------|---|----------------|--|
| | | | Inland Surface Water | Public Sewerage system connected to treatment at second stage | Irrigated Land | |
| 1 | Ammoniacal Nitrogen (as Elementary N) | mg/l | 50 | 75 | 75 | - |
| 2 | Ammonia (as free Ammonia) | mg/l | 5 | 5 | 15 | - |
| 3 | Arsenic (As) | mg/l | 0.2 | 0.05 | 0.2 | - |
| 4 | BOD ₅ At 20°C | mg/l | 50 | 250 | 100 | 30 |
| 5 | Boron (B) | mg/l | 2 | 2 | 2 | - |
| 6 | Cadmium (Cd) | mg/l | 0.5 | 0.05 | 0.05 | - |
| 7 | Chloride | mg/l | 600 | 600 | 600 | - |
| 8 | Chromium (as Total Cr) | mg/l | 0.5 | 1.0 | 1.0 | - |
| 9 | COD | mg/l | 200 | 400 | 400 | 125 |
| 10 | Chromium (as Hexavalent Cr) | mg/l | 0.1 | 1.0 | 1.0 | - |
| 11 | Copper (Cu) | mg/l | 0.5 | 3.0 | 3.0 | - |
| 12 | Dissolved Oxygen (DO) | mg/l | 4.5-8 | 4.5-8 | 4.5-8 | - |
| 13 | Electro Conductivity (EC) | Micromho / cm | 1200 | 1200 | 1200 | - |
| 14 | Total Dissolved Solids (TDS) | mg/l | 2100 | 2100 | 2100 | 50 |
| 15 | Fluoride (F) | mg/l | 2 | 15 | 10 | - |
| 16 | Sulfide (S) | mg/l | 1 | 2 | 2 | - |
| 17 | Iron (Fe) | mg/l | 2 | 2 | 2 | - |
| 18 | Total Kjeldahl nitrogen (N) | mg/l | 100 | 100 | 100 | 10 (Total Nitrogen) |
| 19 | Lead (Pb) | mg/l | 0.1 | 1 | 0.1 | - |
| 20 | Manganese (Mn) | mg/l | 5 | 5 | 5 | - |
| 21 | Mercury (Hg) | mg/l | 0.01 | 0.01 | 0.01 | - |
| 22 | Nickel (Ni) | mg/l | 1.0 | 2.0 | 1.0 | - |
| 23 | Nitrate (as Elementary N) | mg/l | 10.0 | Not yet set | 10 | - |
| 24 | Oil And Grease | mg/l | 10 | 20 | 10 | 10 |
| 25 | Phenolic Compounds (as C ₆ H ₅ OH) | mg/l | 1.0 | 5 | 1.0 | - |
| 26 | Dissolved Phosphorus (P) | mg/l | 8 | 8 | 15 | 2 (Total Phosphorous) |
| 27 | Radioactive Substance | (To be specified by Bangladesh Atomic Energy Commission) | | | | - |

Am

Dr

| SI | Parameters | Unit | Discharge To ^a | | | IFC Standard 2007, Treated Sanitary Sewage Discharge to Inland Surface Water |
|----|-----------------------|-------------|---------------------------|---|----------------|--|
| | | | Inland Surface Water | Public Sewerage system connected to treatment at second stage | Irrigated Land | |
| 28 | pH | -- | 6-9 | 6-9 | 6-9 | 6-9 |
| 29 | Selenium (Se) | mg/l | 0.05 | 0.05 | 0.05 | - |
| 30 | Zinc (Zn) | mg/l | 5 | 10 | 10 | - |
| 31 | Temperature | °C (summer) | 40 | 40 | 40 | - |
| | | °C (winter) | 45 | 45 | 45 | - |
| 32 | Suspended Solids (SS) | mg/l | 150 | 500 | 200 | 50 (TSS) |
| 33 | Cyanide (Cn) | mg/l | 0.1 | 2.0 | 0.2 | - |
| 34 | Total Coliform | P /100ml | | | | 400 |

a/Schedule 10 Standards for Waste from Industrial Units or Projects Waste

Notes:

1. These standards shall be applicable to all industries or projects other than those specified under the heading "Standards for sector wise industrial effluent or emission."
2. Compliance with these standards shall be ensured from the moment an industrial unit starts trial production, and in other cases, from the moment a project starts operation.
3. These standards shall be inviolable even in case of any sample collected instantly at any point of time. These standards may be enforced in a more stringent manner if considered necessary in view of the environmental conditions of a particular situation.
4. Inland Surface Water means drains/ponds/tanks/water bodies/ ditches, canals, rivers, springs and estuaries.
5. Public sewerage system means treatment facilities of the first and second stage and also the combined and complete treatment facilities.
6. Irrigable land means such land area which is sufficiently irrigated by wastewater taking into consideration the quantity and quality of such water for cultivation of selected crops on that land.
7. Inland Surface Water Standards shall apply to any discharge to a public sewerage system or to land if the discharge does not meet the requirements of the definitions in notes 5 and 6 above.

b/IFC World Bank Group. 2007. Environmental, Health and Safety General Guidelines. Washington, D.C.

MPM=Maximum Probable Number

Table 3.5: Applicable Inland Surface Water Quality Standards (ECR-2023)

| Best Practice Based classification | pH | DO mg/l | BOD mg/l | NO ₃ -N mg/l | NH ₄ -N mg/l | PO ₄ -P mg/l | Total Cr mg/l | Pb mg/l | Hg mg/l | Total Coliform cfu/100mg | TDS mg/l | COD mg/l |
|---|---------|------------|-------------|----------------------------|----------------------------|----------------------------|---------------------|------------|------------|--------------------------------|-------------|-------------|
| a. Source of drinking water for supply only after disinfecting: | 6.5-8.5 | ≥6 | ≤2 | 7.0 | 0.1 | 0.1 | 0.02 | 0.03 | 0.001 | ≤100 | 1000 | 10 |
| b. Water usable for recreational activity | 6.5-8.5 | ≥5 | ≤3 | 7.0 | 0.3 | 0.5 | 0.2 | 0.05 | 0.001 | ≤50 | 1000 | 10 |
| c. Source of drinking water for supply after conventional treatment | 6-9 | ≥5 | ≤3 | 7.0 | 0.3 | 0.5 | 0.02 | 0.03 | 0.001 | ≤5000 | 1000 | 25 |
| d. Water usable by fisheries | 6-9 | ≥5 | ≤6 | 7.0 | 0.3 | 0.5 | 0.05 | 0.1 | 0.004 | ≤5000 | 1000 | 50 |
| e. Water usable by various process and cooling industries | 6.5-8.5 | ≥1 | 12 | - | 2.7 | - | 0.1 | 0.1 | 0.05 | - | 1000 | 100 |
| f. Water usable for irrigation | 6.5-8.5 | - | ≤12 | 5.0 | 1.5 | 2.0 | 0.1 | 0.1 | 0.002 | ≤50000 | 1000 | 100 |

Om

Dr.

Table 3.6: Reference Levels for Occupational Exposure to Time-Varying Electric and Magnetic Fields

| Frequency range | E-Field Strength (V/m) | H-Field Strength (A/m) | B-Field (μT) | Equivalent plane wave power density S_{eq} (W/m^2) |
|-----------------|------------------------|------------------------|---------------------------|---|
| up to 1 Hz | — | 1.63×10^5 | 2×10^5 | — |
| 1–8 Hz | 20,000 | $1.63 \times 10^5/f^2$ | $2 \times 10^5/f^2$ | — |
| 8–25 Hz | 20,000 | $2 \times 10^4/f$ | $2.5 \times 10^4/f$ | — |
| 0.025–0.82 kHz | $500/f$ | $20/f$ | $25/f$ | — |
| 0.82–65 kHz | 610 | 24.4 | 30.7 | — |
| 0.065–1 MHz | 610 | $1.6/f$ | $2.0/f$ | — |
| 1–10 MHz | $610/f$ | $1.6/f$ | $2.0/f$ | — |
| 10–400 MHz | 61 | 0.16 | 0.2 | 10 |
| 400–2,000 MHz | $3f^{1/2}$ | $0.008f^{1/2}$ | $0.01f^{1/2}$ | $f/40$ |
| 2–300 GHz | 137 | 0.36 | 0.45 | 50 |

Table 3.7: Reference Levels for General Public Exposure to Time-Varying Electric and Magnetic Fields

| Frequency range | E-Field Strength (V/m) | H-Field Strength (A/m) | B-Field (μT) | Equivalent plane wave power density S_{eq} (W/m^2) |
|-----------------|------------------------|------------------------|---------------------------|---|
| up to 1 Hz | — | 3.2×10^4 | 4×10^4 | — |
| 1–8 Hz | 10,000 | $3.2 \times 10^4/f^2$ | $4 \times 10^4/f^2$ | — |
| 8–25 Hz | 10,000 | $4,000/f$ | $5,000/f$ | — |
| 0.025–0.8 kHz | $250/f$ | $4/f$ | $5/f$ | — |
| 0.8–3 kHz | $250/f$ | 5 | 6.25 | — |
| 3–150 kHz | 87 | 5 | 6.25 | — |
| 0.15–1 MHz | 87 | $0.73/f$ | $0.92/f$ | — |
| 1–10 MHz | $87/f^{1/2}$ | $0.73/f$ | $0.92/f$ | — |
| 10–400 MHz | 28 | 0.073 | 0.092 | 2 |
| 400–2,000 MHz | $1.375f^{1/2}$ | $0.0037f^{1/2}$ | $0.0046f^{1/2}$ | $f/200$ |
| 2–300 GHz | 61 | 0.16 | 0.2 | 10 |

Source: ICNIRP (International Commission on Non-Ionizing Radiation Protection) Guidelines 1998. Guidelines for Limiting Exposure to Time-Varying Electric, Magnetic, and Electromagnetic Fields (up to 300 GHz)

Note:

- i) f as indicated in the frequency range column.
- ii) Provided that basic restrictions are met and adverse indirect effects can be excluded, field strength values can be exceeded.
- iii) For frequencies between 100 kHz and 10 GHz, S_{eq} , E^2 , H^2 , and B^2 are to be averaged over any 6-min period.
- iv) For frequencies exceeding 10 GHz, S_{eq} , E^2 , H^2 , and B^2 are to be averaged over any $68/f^{1.05}$ -min period (f in GHz).
- v) No E-field value is provided for frequencies <1 Hz, which are effectively static electric fields. Electric shock from low impedance sources is prevented by established electrical safety procedures for such equipment.

Table 3.8: Minimum Limits for Workplace Illumination Intensity (IFC 2007)

| Location / Activity | Light Intensity |
|---|-------------------|
| Emergency light | 10 lux |
| Outdoor non-working areas | 20 lux |
| Simple orientation and temporary visits (Machine storage, garage, warehouse) | 50 lux |
| Workspace with occasional visual tasks only (Corridors, stairways, lobby, elevator, auditorium, etc.) | 100 lux |
| Medium precision work (Simple assembly, rough machine works, welding, packing, etc.) | 200 lux |
| Precision work (Reading, moderately difficult assembly, sorting, checking, medium bench and machine works, etc.), offices. | 500 lux |
| High precision work (Difficult assembly, sewing, color inspection, fine sorting etc.) | 1,000 – 3,000 lux |

Table 3.9: Vibration Standard

| Group | Type of Structure | Guideline Values for Velocity (mm/s) | | | | |
|-------|---|--------------------------------------|----------------|-----------------|-----------------|------------------|
| | | Short-Term | | | Long-Term | |
| | | At Foundation | | | Uppermost Floor | Uppermost Floor |
| | | Less Than 10 Hz | 10 Hz To 50 Hz | 50 Hz To 100 Hz | All Frequencies | All Frequencies |
| 1 | Buildings used for commercial purposes, industrial buildings and buildings of similar design | 20 | 20 to 40 | 40 to 50 | 40 | 10 |
| 2 | Residential dwellings and buildings of similar design and/or use | 5 (105 dB) | 5 to 15 | 15 to 20 | 15 | 5 (105 dB) |
| 3 | Structures that because of their particular sensitivity to vibration, do not correspond to those listed in Lines 1 or and have intrinsic value (e.g. buildings that are under a preservation order) | 3 (100.5 dB) | 2 to 8 | 8 to 10 | 8 | 2.5 (99.0 dB) |

Source: DIN 4150-3, Structural Vibration, Part 3: Effect of vibration on structures

Annex 4: Environmental Codes Of Practices

Introduction

The objective of the Environmental Codes of Practice (ECPs) is to address all potential general construction related impacts during implementation of the Project. The ECPs provide guidelines for international good practices and environmental management guidelines to be followed by the contractors for management of all environmental issues. These ECPs as part of the EMP will be annexed to the general conditions of all the contracts, including subcontracts, carried out under the Project.

The list of ECPs prepared for the Project is:

- ECP 1: Waste Management
- ECP 2: Fuels, Oils and Other Hazardous Substances Management
- ECP 3: Water Resources Management
- ECP 4: Drainage Management
- ECP 5: Soil Quality Management
- ECP 6: Erosion and Sediment Control
- ECP 7: Top Soil Management
- ECP 8: Topography and Landscaping
- ECP 9: Borrow Areas Management (note that borrow areas and dredging not permitted, only existing licensed sources are to be used)
- ECP 10: Air Quality Management
- ECP 11: Noise and Vibration Management
- ECP 12: Protection of Flora
- ECP 13: Protection of Fauna
- ECP 14: Protection of Fisheries
- ECP 15: Road Transport and Road Traffic Management
- ECP 16: Construction Camp Management
- ECP 17: Cultural and Religious Issues
- ECP 18: Workers Health and Safety including Labor Accommodation

Contractors will prepare Construction Environmental and Social Management Plans (CESMPs) and H&S Plans with sub-plans for each contract/construction site in compliance with ADB and Government of Bangladesh requirements as set out in the EMP and SCC/ECC respectively and based on the guidance given in the ECPs. The contractors' implementation of the CESMPs and H&S Plans will be supervised and monitored by NESCO along with implementation of the EMP and SCC/ECC requirements. It is mandatory for the contractors procured directly by the Project to include these ECPs in their subcontracts along with the requirements from the EMP and SCC/ECC applicable to subcontractor activities. Non-compliance by the contractors procured directly by the Project or their subcontractors will require corrective action to be taken or penalties being imposed on the contractors.

ECP 1: Waste Management

| Project Activity/Impact Source | Environmental Impacts | Mitigation Measures/ Management Guidelines |
|---------------------------------------|---|--|
| Solid Waste and Wastewater Generation | Health hazards and soil and water pollution from the improper management of excess materials including inert spoil from any earthworks, solid wastes and wastewater | <p>The Contractor will:</p> <ul style="list-style-type: none"> • Prepare and follow the site-specific waste management plan covering all waste streams (e.g., reusable and recyclable waste, flammable waste, construction debris, food waste, e-waste etc.) submitted to PIU and PIAC for approval • Organize disposal of all wastes generated during construction in the designated disposal sites. • Minimize the production of waste materials by 3R (Reduce, Recycle and Reuse) approach. • Segregate and reuse or recycle all the wastes, wherever practical. • Vehicles transporting loose materials and solid waste will be covered with tarpaulins or nets to prevent spilling waste along the route. • Train and instruct all personnel in waste management practices and procedures as a component of the environment management induction process. • Request suppliers to minimize packaging where practicable. • Place a high emphasis on good housekeeping practices. • Maintain all construction sites in a clean, tidy and safe condition. • Provide refuse containers at each worksite. • Provide and maintain appropriate waste management facilities for the temporary storage of all waste types before transportation and final disposal. • Plastic bag and container use to be avoided. • Potable water imported to be supplied in bulk containers to reduce the quantity of plastic waste (plastic bottles). |
| Hazardous Waste Generation | Health hazards and soil and water pollution from the improper management of excess hazardous materials and hazardous waste | <p>The Contractor will</p> <ul style="list-style-type: none"> • Collect chemical wastes in 200-liter drums (or similar sealed container), appropriately labelled for safe transport to an approved chemical waste depot. • Store, transport and handle all chemicals avoiding potential environmental pollution. • Store all hazardous wastes appropriately in banded areas away from water courses. • Make available Material Safety Data Sheets (MSDS) for hazardous materials on-site during construction. • Collect hydrocarbon wastes, including lube oils, for safe transport off-site for reuse, recycling, treatment or disposal at approved locations. • Construct 110% volume of storage banded impermeable platform made of concrete or other impermeable flooring to prevent seepage in case of spills. |

Orin

ds'

ECP 2: Fuels, Oils and Other Hazardous Substances Management

| Project Activity/ Impact Source | Environmental Impacts | Mitigation Measures/ Management Guidelines |
|---|---|---|
| <p>Use of fuels, oils, chemicals and other hazardous substances</p> | <p>Materials used in construction have the potential to be a source of contamination. Improper storage and handling of fuels, lubricants, chemicals and hazardous goods/materials on-site, and potential spills from these goods may harm the environment or health of construction workers and/or communities in the vicinity.</p> | <p>The Contractor will:</p> <ul style="list-style-type: none"> • Prepare and follow spill control procedures and submit them for PIU and PIAC approval. • Train the relevant construction personnel in handling of fuels, oils (such as transformer oils) and spill control procedures. • Store dangerous goods in bunded areas on top of a sealed plastic sheet away from watercourses. • Refuelling will occur only within bunded areas. • Store and use fuels in accordance with material safety data sheets (MSDS). • Make available MSDS for chemicals and dangerous goods on-site. • Transport hazardous which cannot be recycled, to a suitably licensed and designed hazardous waste facility for disposal. • Provide absorbent and containment material (e.g., absorbent matting) where hazardous materials are used and stored; and ensure personnel trained in the correct use. • Provide protective clothing, safety boots, helmets, masks, gloves, goggles, to the construction personnel, appropriate to materials in use. • Make sure all containers, drums, and tanks that are used for storage are in good condition and are labeled with expiry date. Any container, drum, or tank that is dented, cracked, or rusted might eventually leak. Check for leakage regularly to identify potential problems before they occur. • Store all liquid fuels in fully bunded storage containers, with appropriate volumes, a roof, a collection point and appropriate filling/decanting point. • Store hazardous materials above flood level considered for construction purposes • Put containers and drums in temporary storages in clearly marked areas, where they will not be run over by vehicles or heavy machinery. The area will preferably have slope or drain so that the fuels or hazardous lubricants can be safely collected in an event of a spill. • Take all precautionary measures when handling and storing fuels and lubricants, avoiding environmental pollution. |

| Project Activity/ Impact Source | Environmental Impacts | Mitigation Measures/ Management Guidelines |
|------------------------------------|-----------------------|--|
| | | <ul style="list-style-type: none">• Avoid the use of materials with high potential for contamination by substituting them with environmentally friendly materials e.g., biodegradable. |



ECP 3: Water Resources Management

| Project Activity/ Impact Source | Environmental Impacts | Mitigation Measures/ Management Guidelines |
|------------------------------------|--|---|
| Hazardous material and waste | Water pollution from the storage, handling and disposal of hazardous materials and general construction waste, and accidental spillage | <p>The Contractor will</p> <ul style="list-style-type: none"> • Follow the management guidelines proposed in ECPs 1 and 2. • Minimize the generation of sediment, oil and grease, excess nutrients, organic matter, litter, debris and any form of waste (particularly petroleum and chemical wastes). These substances must not enter waterways or storm water systems. |
| Discharge from construction sites | Construction activities, sewerage from construction sites and work camps may affect the surface water quality. The construction works will modify the groundcover and topography changing the surface water drainage patterns of the area. These changes in hydrological regime may lead to an increased rate of runoff, increase in sediment and contaminant loading, increased flooding, and affect habitat of fish and other aquatic biology. | <p>The Contractor will</p> <ul style="list-style-type: none"> • Install temporary drainage works (channels and bunds) in areas required for sediment and erosion control and around storage areas for construction materials. • Install temporary sediment basins, where appropriate, to capture sediment-laden runoff from site. • Divert runoff from undisturbed areas around the construction site. • Stockpile materials away from drainage lines • Prevent all solid and liquid wastes entering waterways by collecting solid waste, oils, chemicals, bitumen spray waste and wastewaters from brick, concrete and asphalt cutting where possible and transport to an approved waste disposal site or recycling depot. • Wash out ready-mix concrete agitators and concrete handling equipment at washing facilities off site or into approved bunded areas on site. Ensure that tires of construction vehicles are cleaned in the washing bay (constructed at the entrance of the construction site) to remove the mud from the wheels. This should be done in every exit of each construction vehicle to ensure the local roads are kept clean. • Sewerage and grey water from portable toilets on the construction site and labor camps is to be collected and tankered off for offsite treatment and disposal. • Dewater sites by pumping water to a sediment basin prior to release off site – do not pump directly off site. • Protect water bodies from sediment loads by silt screen or other barriers. |
| Soil erosion and siltation | Soil erosion and dust from the material stockpiles will increase the sediment and | <p>The Contractor will</p> <ul style="list-style-type: none"> • Stabilize the cleared areas not used for construction activities with vegetation or appropriate surface treatments as soon as |

| Project Activity/ Impact Source | Environmental Impacts | Mitigation Measures/ Management Guidelines |
|---|---|--|
| | contaminant loading of surface water bodies. | <p>practicable following earthwork to minimize erosion.</p> <ul style="list-style-type: none"> • Ensure that roads used by construction vehicles are swept regularly to remove dust and sediment. • Spray water regularly to reduce air borne particles after cleaning. • Spray water on the loose material stockpiles, access roads and bare soils on an as required basis to minimize dust. Increase the watering frequency during periods of high risk (e.g., high winds). |
| Construction activities in water bodies | Construction works in the water bodies will increase sediment and contaminant loading, and effect habitat of fish and other aquatic biology | <p>The Contractor will</p> <ul style="list-style-type: none"> • Dewater sites by pumping water to a sediment basin prior to release off site – and should not pump directly off site into fields or canals and ditches. • Protect water bodies from sediment loads by silt screen or other barriers. • Minimize the generation of sediment, oil and grease, excess nutrients, organic matter, litter, debris and any form of waste (particularly petroleum and chemical wastes). These substances must not enter waterways or storm water systems • Do not discharge cement and curing water used for cement concrete directly into water courses and drainage inlets. • Monitor the water quality in the runoff from the site or areas affected by dredge plumes, and improve work practices as necessary • Use environment friendly and nontoxic slurry during construction of piles and avoid discharge into the river. • Reduce infiltration of contaminated drainage through storm water management design |
| Drinking water | Untreated surface water is not suitable for drinking purposes due to presence of suspended solids and E. coli. | <p>The Contractor will</p> <ul style="list-style-type: none"> • Provide drinking water according to peak construction labor/O&M staff deployed at site that meets national and WBG EHS Guidelines. • Pumping of groundwater shall be from deep aquifers of more than 300 m to supply arsenic free water. Safe and sustainable discharges are to be ascertained prior to selection of pumps. • Tube wells will be installed with due regard for the surface environment, protection of groundwater from surface contaminants, and protection of aquifer cross contamination |

| Project Activity/ Impact Source | Environmental Impacts | Mitigation Measures/ Management Guidelines |
|------------------------------------|--|--|
| | | <ul style="list-style-type: none"> All tube wells, test holes, monitoring wells that are no longer in use or needed shall be properly decommissioned |
| | Depletion and pollution of groundwater resources | <p>The Contractor will</p> <ul style="list-style-type: none"> Install monitoring wells both upstream and downstream areas near construction yards and construction camps to regularly monitor the water quality and water levels. Protect groundwater supplies of adjacent lands |

ECP 4: Drainage Management

| Project Activity/ Impact Source | Environmental Impacts | Mitigation Measures/ Management Guidelines |
|---|--|--|
| Excavation and earth work, and construction yards | Lack of proper drainage for rainwater/liquid waste or wastewater owing to the construction activities harms environment in terms of water and soil contamination, and mosquito growth. | <p>The Contractor will</p> <ul style="list-style-type: none"> • Prepare and follow drainage management procedures submitted to PIU and PIAC approval. • Prepare a program to prevent/avoid standing waters, which PIU and PIAC will verify in advance and confirm during implementation. • Provide alternative drainage for rainwater if the construction works/earth-filling cut the established drainage line. • Establish local drainage line with appropriate silt collector and silt screen for rainwater or wastewater connecting to the existing established drainage lines already there. • Rehabilitate road drainage structures immediately if damaged by contractors' road transports. • Build new drainage as appropriate with oil interceptors connecting to the available nearby recipient water bodies. • Ensure wastewater quality conforms to national and WBG EHS Guidelines before it is being discharged into the recipient water bodies. • Ensure that there will be no water stagnation at the construction sites and camps. • Provide appropriate silt collector and silt screen at the inlet and manholes and periodically clean the drainage system to avoid drainage congestion. • Protect natural slopes of drainage channels to ensure adequate storm water drains. • Regularly inspect and maintain all drainage channels to assess and alleviate any drainage congestion problem. • Reduce infiltration of contaminated drainage through storm water management design |
| Ponding of water | Health hazards due to mosquito breeding | <p>The contractor will</p> <ul style="list-style-type: none"> • Not allow ponding of water especially near the waste storage areas and construction camps. • Discard all the storage containers that are capable of storing of water, after use or store them in inverted position. |

ECP 5: Soil Quality Management

| Project Activity/ Impact Source | Environmental Impacts | Mitigation Measures/ Management Guidelines |
|--|--|--|
| Filling of Sites with dredge spoils | Soil contamination will occur from drainage of dredged spoils | <p>The Contractor shall</p> <ul style="list-style-type: none"> • Ensure that dredged sand used for land filling shall be free of pollutants. Prior to filling, sand quality shall be tested to confirm whether soil is pollution free. Sediments shall be properly compacted. Top layer shall be the 0.5 m thick clay on the surface and boundary slopes along with grass. Side Slope of Filled Land of 1:2 shall be constructed by suitable soils with proper compaction as per design. Slope surface shall be covered by top soils/ cladding materials (0.5m thick) and grass turfing with suitable grass. • Leaching from the sediments shall be contained to seep into the subsoil or shall be discharged into settling lagoons before final disposal. • No sediment laden water in the adjacent lands near the construction sites, and/or wastewater of suspended materials excessive of 200mg/l from dredge spoil storage/use area in the adjacent agricultural lands • Ensure sand and gravel sourcing/selection of government licensed sand and gravel suppliers from legally permitted sites i.e. ensure no illegally extracted sand and gravel is used for the project which may negatively impact any sensitive aquatic life and hydrology of the adjoining river systems at the sites. |
| Storage of hazardous and toxic chemicals | Spillage of hazardous and toxic chemicals will contaminate the soils | <p>The Contractor will</p> <ul style="list-style-type: none"> • Strictly manage the wastes management plans proposed in ECP1 and storage of materials in ECP2. • Construct appropriate spill contaminant facilities for all fuel storage areas. • Establish and maintain a hazardous material register detailing the location and quantities of hazardous substances including the storage, and their disposals. • Train personnel and implement safe work practices for minimizing the risk of spillage. • Identify the cause of contamination, if it is reported, and contain the area of contamination. The impact may be contained by isolating the source or implementing controls around the affected site. |

| Project Activity/ Impact Source | Environmental Impacts | Mitigation Measures/ Management Guidelines |
|------------------------------------|---|--|
| | | <ul style="list-style-type: none"> • Store all hazardous and chemical in a 110% volume of bunded impermeable concrete platform and clearly demarcate the area • Remediate the contaminated land using the most appropriate available method. |
| Construction material stockpiles | Erosion from construction material stockpiles may contaminate waterbodies | <p>The Contractor will</p> <ul style="list-style-type: none"> • Protect the toe of all stockpiles, where erosion is likely to occur, with silt fences, straw bales or bunds. |

ECP 6: Erosion and Sediment Control

| Project Activity/ Impact Source | Environmental Impacts | Mitigation Measures/ Management Guidelines |
|---|---|---|
| Clearing of construction sites | Cleared areas and slopes are susceptible for erosion of topsoils, which affects the growth of vegetation and causes ecological imbalance. | <p>The Contractor will</p> <ul style="list-style-type: none"> • Prepare and follow site specific erosion and sediment control measures and submit them for PIU and PIAC approval. • Reinstate and protect cleared areas as soon as possible in timeframe approved by PIU/PIAC. • Cover unused areas of disturbed or exposed surfaces immediately with mulch/grass turf/tree plantations. |
| Construction activities and material stockpiles | Soil erosion and dust from the material stockpiles will increase the sediment and contaminant loading of surface water bodies. | <p>The Contractor will</p> <ul style="list-style-type: none"> • Locate stockpiles away from drainage lines. • Protect the toe of all stockpiles, where erosion is likely to occur, with silt fences, straw bales or bunds. • Remove debris from drainage paths and sediment control structures. • Cover the loose sediments of construction material and water them if required. • Divert natural runoff around construction areas prior to any site disturbance. • Install protective measures on site prior to construction, for example, sediment traps. • Install 'cut off drains' on large cut/fill batter slopes to control water runoff speed and hence erosion. • Observe the performance of drainage structures and erosion controls during rain and modify as required. |
| Soil erosion and siltation | The impacts of soil erosion are (i) increased run off and sedimentation causing a greater flood hazard to the downstream, and (ii) destruction of aquatic environment by erosion and/or deposition of sediment damaging the spawning grounds of fish and avifauna feeding areas | <p>The Contractor will:</p> <ul style="list-style-type: none"> • Stabilize the cleared areas not used for construction activities with vegetation or appropriate surface water treatments as soon as practicable following earthwork to minimize erosion. • Ensure that roads used by construction vehicles are swept regularly to remove sediment. • Water the material stockpiles, access roads and bare soils on an as required basis to minimize dust. Increase the watering frequency during periods of high risk (e.g. high winds). • Remove any sediment that deposits in spawning areas from the drains from the construction site after every inspection every month. |

ECP 7: Top Soil Management

| Project Activity/ Impact Source | Environmental Impacts | Mitigation Measures/ Management Guidelines |
|------------------------------------|--|---|
| Land clearing and earth works | Earthworks will impact the fertile top soils that are enriched with nutrients required for plant growth or agricultural development. | <p>The Contractor will</p> <ul style="list-style-type: none"> • Strip the top soil to a depth of 15 cm and store in stock piles of height not exceeding 2m. • Remove unwanted materials from top soil like grass, roots of trees and etc. and mulch and dry compost if possible • Stockpiles will be done in slopes of 2:1 to reduce surface runoff and enhance percolation through the mass of stored soil. • Locate topsoil stockpiles in areas outside drainage lines and protect from erosion. • Construct diversion channels and silt fences around the topsoil stockpiles to prevent erosion and loss of topsoil. • Spread the topsoil to maintain the physio-chemical and biological activity of the soil. • Stored top soil will be utilized for covering all disturbed area and plantation sites. • Prior to the re-spreading of topsoil, the ground surface will be ripped to assist the binding of the soil layers, water penetration and revegetation |
| Transport | Vehicular movement outside campus or temporary access roads will affect the soil fertility of the agricultural lands | <p>The contractor will:</p> <ul style="list-style-type: none"> • Limit equipment and vehicular movements to within the approved construction zone. • Construct temporary access tracks/culverts to cross concentrated water flow lines at right angles • Plan construction access to make use, if possible, of the final road alignment • Use vehicle-cleaning devices, for example, ramps or wash down areas and ensure that tires of construction vehicles are cleaned in the washing bay (constructed at the entrance of the construction site) to remove the mud from the wheels. This should be done on every exit of each construction vehicle to ensure the local roads are kept clean. |

ECP 8: Topography and Landscaping

| Project Activity/ Impact Source | Environmental Impacts | Mitigation Measures/ Management Guidelines |
|------------------------------------|--|--|
| Land clearing and earth works | Construction activities especially earthworks will change the topography and disturb the natural rainwater/flood water drainage as well as changing the local landscape. | <p>The Contractor will</p> <ul style="list-style-type: none"> • Prepare a landscaping and tree plantation plan and submit the plan for PIU and PIAC approval. • Ensure the topography of the final surface of all raised lands (construction sites, access roads, etc.) are conducive to enhance natural draining of rainwater/flood water. • Keep the final or finished surface of all the raised lands free from any kind of depression that causes water logging. • Undertake erosion control/prevention by grass-turfing and tree plantation, where there is a possibility of rain-cut that will change the shape of topography. • Cover immediately the uncovered open surface that has no use of construction activities with grass-cover and tree plantation to prevent soil erosion and bring improved landscaping. • Reinstate the natural landscape of the temporary construction sites after completion of works. |

ECP 9: Borrow Areas Management

(note that borrow areas and dredging not permitted, only existing licensed sources are to be used)

| Project Activity/ Impact Source | Environmental Impacts | Mitigation Measures/ Management Guidelines |
|---|---|---|
| Development and operation of borrow areas | Borrow areas will have impacts on local topography, landscaping and natural drainage. | <p>The Contractor will</p> <ul style="list-style-type: none"> - Use only approved quarry and borrow sites as specified in ECP 5: Soil Quality Management - Reuse excavated material available from the project to the maximum extent possible. - Store top soil for reinstatement and landscaping. <p>New borrow areas and quarries will not be used unless the IEE has been updated to assess the impact of them</p> <ul style="list-style-type: none"> - Identify new borrow and quarry areas in consultation with PMU, if required. - Undertake ecology survey, physical baseline surveys, and inventorization of receptors to inform IEE update prior to selection - Not use agriculture areas or ecologically sensitive areas as borrow sites - Develop surface water collection and drainage systems, anti-erosion measures (berms, revegetation etc.) and retaining walls and gabions where required. - Implement mitigation measures in ECP 3: Water Resources Management, ECP 6: Erosion and Sediment Control - The use of explosive should be used in as much minimum quantity as possible to reduce noise, vibration and dust. - Control dust and air quality deterioration by application of watering and implementing mitigation measures proposed in ECP 10: Air Quality Management - Noise and vibration control by ECP 11: Noise and Vibration Management. - Maintain record of all sand or gravel extraction (quantities, location shown on map, timing, any sighting of key species). |
| Dredging from the rivers | Increased turbidity, loss of transparency and increased suspended sediment concentrations. Impact on benthic habitats | <p>The Contractor will</p> <ul style="list-style-type: none"> - Use sand and gravel only from existing licensed dredging sources as specified in ECP 5: Soil Quality Management - Reuse excavated material available from the project to the maximum extent possible. - Store top soil for reinstatement and landscaping. <p>Dredging by the contractor will not be used unless the IEE has been updated to assess the impact of this</p> <ul style="list-style-type: none"> - Identify dredging areas in consultation with PMU, if required. - Undertake ecology survey, physical baseline surveys, and inventorization of receptors to inform IEE update prior to selection - Avoid destruction or alteration of habitats which may result in a reduction of biodiversity for the ecosystem and may potentially lead to changes in water quality parameters. - Not use ecologically sensitive areas as dredging sites - Select dredging equipment (e.g. Cutter Suction Dredger) which are known to have a low risk of sediment dispersal. The suction action inside the Cutter Suction Dredger means that most of the sediment removed by the cutter is captured. As high dredging efficiency and low turbidity at the cutter head are closely linked, |

| Project Activity/ Impact Source | Environmental Impacts | Mitigation Measures/ Management Guidelines |
|---|--|--|
| | | <p>it is uncommon for turbidity generated by the cutter head to cause environmental concern.</p> <ul style="list-style-type: none"> - Monitor the dredging operation and, if necessary, modify operations, e.g. restrict the amount of material being dredged (or the number of dredgers allowed to operate) at any one time - Maintain record of all sand or sediment extraction (quantities, location shown on map, timing, any sighting of key species). |
| <p>Sand placement at temporary locations prior to shifting or direct placement on the proposed site for filling</p> | <p>Dispersion of sediments and release of high sediment laden runoff from the placement sites.</p> | <p>The Contractor will</p> <ul style="list-style-type: none"> - To the extent possible, shall directly place the sediments for filling the proposed disposal areas. - If pipeline is required for filling then the IEE will need to be updated to reflect the impact of the route. - Prior to filling commencing, the areas being filled will be subdivided into compartments by construction of temporary containment bunds of suitable material (e.g. sheet piles or earthen bund, dredged sand is not suitable). - Filling will be achieved by progressively pumping a slurry of sand and water into the bunded areas, allowing the surplus water to drain away to artificial and natural waterways in a controlled manner through the pipeline, without affecting floodplains. - Control the discharge of site runoff, including excess dredge water, by the installation and correct use of containment walls, bunds and weirs. - Monitor the quality of water (e.g. sediment content) in site runoff to confirm that the design and operation of the containment walls, bunds and weirs, and the retention time for dredge waters which facilitates the settlement out of fine sediments prior to discharge off site, is adequate. - If required, additional siltation ponds are to be provided to divert the runoff water and allow further settlement before discharge to that there is no sediment laden runoff. - Ensure adjacent land and waterbodies do not experience sedimentation and waterlogging. |

ECP 10: Air Quality Management

| Project Activity/ Impact Source | Environmental Impacts | Mitigation Measures/ Management Guidelines |
|------------------------------------|--|--|
| Construction vehicular traffic | Air quality can be adversely affected by vehicle exhaust emissions and combustion of fuels. | <p>The Contractor will</p> <ul style="list-style-type: none"> • Prepare air quality management plan (under the Pollution Prevention Plan) and submit the plan for PIU and PIAC approval. • Fit vehicles with appropriate exhaust systems and emission control devices. Maintain these devices in good working condition. • Operate the vehicles in a fuel-efficient manner. • Cover haul vehicles carrying dusty materials moving outside the construction site. • Impose speed limits on all vehicle movement at the worksite to reduce dust emissions. • Control the movement of construction traffic. • Water construction materials prior to loading and transport. • Service all vehicles regularly to minimize emissions. • Limit the idling time of vehicles to not more than 2 minutes. |
| Construction machinery | Air quality can be adversely affected by emissions from machinery and combustion of fuels. | <p>The Contractor will</p> <ul style="list-style-type: none"> • Fit machinery with appropriate exhaust systems and emission control devices. Maintain these devices in good working condition in accordance with the specifications defined by their manufacturers to maximize combustion efficiency and minimize the contaminant emissions. Proof or maintenance register will be required by the equipment suppliers and contractors. • Focus special attention on containing the emissions from generators. • Machinery causing excess pollution (e.g. visible smoke) will be banned from construction sites. • Service all equipment regularly to minimize emissions. • Provide filtering systems, duct collectors or humidification or other techniques (as applicable) to any concrete batching and mixing plant to control the particle emissions in all its stages, including unloading, collection, aggregate handling, cement dumping, circulation of trucks and machinery. |
| Construction activities | Dust generation from construction sites, material stockpiles and access roads is not only a nuisance for local | <p>The Contractor will</p> <ul style="list-style-type: none"> • Water the material stockpiles, access roads and bare soils on an as required basis to minimize the potential for environmental nuisance due to dust. Increase the watering |

| Project Activity/ Impact Source | Environmental Impacts | Mitigation Measures/ Management Guidelines |
|--|--|---|
| | <p>people, it aggravates the environment and can bring forth multiple health hazards, and can also affect the local crops</p> | <p>frequency during periods of high risk (e.g., high winds).</p> <ul style="list-style-type: none"> • Stored materials such as gravel and sand will be covered and confined to avoid them being wind-drifted. • Minimize the extent and period of exposure of the bare surfaces. • Restore disturbed areas as soon as practicable by vegetation/grass-turfing. • Store the cement in silos and minimize the emissions from silos by equipping them with filters. • Establish adequate locations for storage, mixing and loading of construction materials, in a way that dust dispersion is prevented because of such operations. • Water must not be used as a means of dust suppression on potentially contaminated areas. • Crushing of rocky and aggregate materials will be wet-crushed or performed with particle emission control systems. • Not permit the burning of solid waste. • Handheld sprays are more effective than hoses attached to equipment as the water can be directed to where it is needed. In addition, high volume water suppression systems, manually controlled, can produce fine water droplets that effectively bring the dust particles to the ground. |
| <p>Air Pollution Monitoring at construction site</p> | <p>Ambient dust in air at construction site causes health issues among workers, adjoining community as well as negatively ecologically sensitive areas</p> | <p>The contractor will</p> <ul style="list-style-type: none"> • Monitor regularly air emissions (as mandated by PIU/PIAC) at site by application of national legislated standards, or WHO Air Quality Guidelines 2021 or other internationally recognized sources (whichever is stringent) to ensure pollutant concentrations at site do not reach or exceed relevant ambient quality guidelines and standards • Ensure suitable mitigation measures that include suppression of particulate matter at site, reduction in exhaust from mobile sources through use of cleaner fuels/technologies and/or use of properly maintained equipment, besides application of comprehensive pollution control measures at site. |

ECP 11: Noise and Vibration Management

| Project Activity/ Impact Source | Environmental Impacts | Mitigation Measures/ Management Guidelines |
|------------------------------------|---|--|
| Construction vehicular traffic | Noise quality will deteriorate due to vehicular traffic | <p>The Contractor will</p> <ul style="list-style-type: none"> • Prepare a noise and vibration management plan (under the Pollution Prevention Plan) and submit the plan for PIU and PIAC approval. • Reduce project traffic routing through community areas wherever possible • Maintain all vehicles in order to keep them in good working order in accordance with manufactures maintenance procedures. • Make sure all drivers comply with the traffic codes concerning maximum speed limit, driving hours, etc. • Organize the loading and unloading of trucks, and handling operations for the purpose of minimizing construction noise on the work site. |
| Construction machinery | Noise and vibration may have an impact on people, property, fauna, livestock and the natural environment. | <p>The Contractor will</p> <ul style="list-style-type: none"> • Appropriately site all noise generating activities to avoid noise pollution to local residents. • Use the equipment with lower sound power levels. i.e. the quietest available plant and equipment. • Installing silencers for fans • Installing vibration isolation for mechanical equipment • Fit high efficiency mufflers to appropriate construction equipment such as on engine exhausts and compressor components • Maintain all equipment in order to keep those in good working condition in accordance with manufactures maintenance procedures. Equipment suppliers and contractors will present proof of maintenance register of their equipment. • Install acoustic enclosures around generators to reduce noise levels. • Install acoustic barriers without gaps and with a continuous minimum surface density of 10 kg/m² in order to minimize the transmission of sound through the barrier. • Avoid the unnecessary use of alarms, horns and sirens. |
| Construction activity | Noise and vibration may have an impact on people, property, fauna, livestock and the natural environment. | <p>The Contractor will</p> <ul style="list-style-type: none"> • Notify adjacent landholders prior to any typical noise events outside of daylight hours. • Limiting the hours of operation for specific pieces of equipment or operations, especially mobile sources operating through community areas |

| Project Activity/ Impact Source | Environmental Impacts | Mitigation Measures/ Management Guidelines |
|---------------------------------------|---|---|
| | | <ul style="list-style-type: none"> • Locate barriers should be close to the source or to the receptor location to be effective • Educate the operators of construction equipment on potential noise problems and the techniques to minimize noise emissions. • Employ best available work practices on-site to minimize occupational noise levels. • Install temporary noise control barriers where appropriate. • Notify potentially affected people if major noise generation activities will be undertaken, e.g. blasting. • Plan activities on site and deliveries to and from site to minimize impact. • Monitor and analyze noise and vibration results and adjust construction practices as required. • Avoid undertaking the high noise generating activities, where possible, when working at night near the residential areas. |
| Noise Monitoring at construction site | Noise at construction site causes health issues among workers, adjoining community as well as negatively ecologically sensitive areas that have birds | <p>The contractor will:</p> <ul style="list-style-type: none"> • Monitor regularly noise emissions (as mandated by PIU/PIAC) at site by application of national legislated standards, or Guidelines for Community Noise, World Health Organization (WHO), (whichever is stringent) to ensure noise impacts do not exceed the prescribed levels or result in a maximum increase in background levels of 3 dB at the nearest receptor location off-site. • Implement noise reduction options that include: <ul style="list-style-type: none"> ○ Re-locating noise sources to less sensitive areas to take advantage of distance and shielding ○ Siting permanent facilities away from community areas if possible ○ Taking advantage of the natural topography as a noise buffer during facility design ○ Developing a mechanism to record and respond to complaints |

ECP 12: Protection of Flora

| Project Activity/ Impact Source | Environmental Impacts | Mitigation Measures/ Management Guidelines |
|---------------------------------|---|--|
| Vegetation clearance | Local flora is important to provide shelter for the birds and small animals, offer fruits and/or timber/firewood, and protect soil erosion. As such damage to flora can have adverse environmental impacts. | <p>The Contractor will</p> <ul style="list-style-type: none"> • Prepare a plan for protection of flora and submit the plan for PIU and PIAC approval. • Minimize disturbance to surrounding vegetation. • Use appropriate type and minimum size of machine to avoid disturbance to adjacent vegetation. • Get approval from PIU and PIAC for clearance of vegetation. • Undertake selective and careful pruning of trees where possible to reduce need of tree removal. • Control noxious weeds by disposing of at a suitably licensed waste management facility. • Clear only the vegetation that needs to be cleared in accordance with the engineering plans and designs. • Not burn off of cleared vegetation – where feasible, chip or mulch and reuse it for the rehabilitation of affected areas, temporary access tracks or landscaping. Mulch provides a seed source, can limit erosion, retains soil moisture and nutrients, and encourages re-growth and protection from weeds. • Return topsoil and mulched vegetation (in areas of native vegetation) to approximately the same area it came from. • Avoid work within the drip-line of trees to prevent damage to the tree roots and compacting the soil. • Minimize the length of time the ground is exposed or excavation left open by clearing and re-vegetate the area at the earliest practically possible. • Ensure excavation works occur progressively and re-vegetation is done at the earliest. • Provide adequate knowledge to the workers regarding nature protection and the need to avoid felling trees during construction. • Supply appropriate fuel in the work camps to prevent fuel wood collection. • These measures are applicable to both the construction areas as well as to any associated activities such as sites for stockpiles, disposal of fill, etc. |

| Project Activity/ Impact Source | Environmental Impacts | Mitigation Measures/ Management Guidelines |
|-----------------------------------|------------------------------|--|
| Cutting of Trees/Lopping of trees | Loss of trees at substations | <p>The Contractor will</p> <ul style="list-style-type: none"> • Prepare a plan for cutting and trimming of trees at substation and buildings and submit the plan for PIU and PIAC approval. • Minimize the number of trees cut by using ecologically balanced detailed design layout. • Felled trees and other cleared or pruned vegetation to be disposed of by authorized agents/forest department. • Any tree species that is protected by law, religious beliefs or is an critically endangered, endangered or vulnerable variety should be retained |

ECP 13: Protection of Fauna

| Project Activity/ Impact Source | Environmental Impacts | Mitigation Measures/ Management Guidelines |
|------------------------------------|---|---|
| Construction activities | The location of construction activities can result in the loss of wildlife habitat and habitat quality, | <p>The Contractor will</p> <ul style="list-style-type: none"> • Prepare a plan for protection of fauna and submit the plan for PIU and PIAC approval. • Limit the construction works within the designated sites allocated to the contractors. • Check the site for animals trapped in, or in danger from site works and use a qualified person (Environmentalist or veterinary) to relocate the animal. |
| | Impact on birds, their habitat and their active nests | <p>The Contractor will</p> <ul style="list-style-type: none"> • Not be permitted to destruct active nests or eggs of birds. • Minimize the tree removal during the bird breeding season. If work must be continued during the bird breeding season, a nest survey will be conducted by a qualified biologist prior to commencing works to identify and locate active nests. • If bird nests are located/detected within the trees or on ledges or the ground, then those areas must be avoided. • Petroleum products must not come in contact with sensitive ecosystems. • Minimize the release of oil, oil wastes or any other substances harmful to birds' habitats, to any water bodies, wetlands or any areas frequented by birds. |
| Night time lighting | Lighting from construction sites and construction camps may affect the visibility of night time migratory birds that use the moon and stars for navigation during their migrations. | <p>The Contractor will</p> <ul style="list-style-type: none"> • Use lower wattage flat fixtures that direct light down and reduce glare, thus reducing light pollution, • Avoid flood lights unless those are absolutely required. • Use motion sensitive lighting to minimize needless lighting. • Use, if possible, green lights that are considered as bird friendly lighting instead of white or red colored lights. • Install light shades or plan the direction of lights to reduce light spilling outside the construction area. |
| Construction camps | Illegal poaching | <p>The Contractor will</p> <ul style="list-style-type: none"> • Provide adequate knowledge to the workers regarding protection of flora and fauna including avifauna that is notified as endangered/ critical/vulnerable species by relevant biodiversity related international agencies such as IUCN etc. |

| Project Activity/ Impact Source | Environmental Impacts | Mitigation Measures/ Management Guidelines |
|------------------------------------|-----------------------|--|
| | | <ul style="list-style-type: none"> • Implement relevant government regulations and enforcements for illegal poaching. • Ensure that staff and subcontractors are trained and empowered to identify, address and report potential environmental problems to these threatened species. |

ECP 14: Protection of Fisheries

| Project Activity/ Impact Source | Environmental Impacts | Mitigation Measures/ Management Guidelines |
|--|---|--|
| Construction activities on the land | The main potential impacts to aquatic flora and fauna are increased suspended solids from earthworks erosion, sanitary discharge from work camps, and hydrocarbon spills and also potential impacts to fisheries are hydrocarbon spills and leaks from riverine transport and disposal of wastes into the river | <p>The Contractor will</p> <p>Follow mitigation measures proposed in ECP 3: Water Resources Management and EC4: Drainage Management.</p> <p>Prepare procedures for protection of fish and other aquatic life and submit those for PIU and PIAC for approval.</p> <p>Ensure the riverine transports, vessels and ships are well maintained and do not have oil leakage to contaminate river water.</p> <p>Contain oil immediately on any waterbody or drainage in case of accidental spillage from equipment,; make an emergency oil spill containment plan (under the Fuels and Other Hazardous Substances Management Plan) to be supported with enough equipment, materials and human resources.</p> <p>Not dump wastes, - be it hazardous or non-hazardous into the nearby water bodies, drains or in the river.</p> <p>Follow proper mitigation for acquiring dredged sand from river for site filling in proposed ECP 9: Borrow Management Areas</p> |
| Construction activities inside water body/pond | Filling of seasonal ponds for site preparation will impact the fishes. | <p>The Contractor will</p> <p>Inspect any area of a water body containing fish that is temporarily isolated for the presence of fish, and all fish shall be captured and released unharmed in adjacent fish habitat</p> <p>Install and maintain fish screens etc. on any water intake with drawing water from any water body that contain fish</p> |

ECP 15: Road Transport and Road Traffic Management

| Project Activity/ Impact Source | Environmental Impacts | Mitigation Measures/ Management Guidelines |
|------------------------------------|--|--|
| Construction vehicular traffic | Increased traffic use of road by construction vehicles will affect the movement of normal road traffic and the safety of the road-users. | <p>The Contractor will</p> <ul style="list-style-type: none"> • Prepare a traffic management plan and submit the plan for PIU and PIAC approval at least 30 days before commencing work on any project component involved in traffic diversion and management. • Include in the traffic management plan to ensure uninterrupted traffic movement during construction: detailed drawings of traffic arrangements showing all detours, temporary road, temporary bridges temporary diversions, necessary barricades, warning signs / lights, and road signs. Updating it as needed if additional traffic routes or traffic diversion and management required. • Strictly follow the traffic management plan and work in close coordination with the local authorities. • Provide signs at strategic locations of the roads complying with the schedules of signs contained in the national traffic regulations. • A designated person, traffic controller, wearing colored vest will be engaged for traffic management. • Install and maintain a display board at each important road intersection on the roads to be used during construction, which shall clearly show the following information in Bangla: <ul style="list-style-type: none"> o Location: chainage and village name o Duration of construction period o Period of proposed detour / alternative route o Suggested detour route map o Name and contact address/telephone number of the concerned personnel o Name and contact address / telephone number of the Contractor o Inconvenience due to ongoing work is sincerely regretted. |
| Pollution incidents | Accidents and spillage of fuels and chemicals | <p>The Contractor will</p> <ul style="list-style-type: none"> • Restrict truck deliveries, where practicable, to day time working hours. • Restrict the transport of oversize loads. • Operate vehicles, if possible, to non-peak periods to minimize traffic disruptions. • Enforce off- and on-site speed limit. |
| Parking nuisance | Parking of construction vehicles or truck trailer bring in construction | <p>The Contractor will</p> <ul style="list-style-type: none"> • Restrain any truck containing deliveries/construction material to park on the main or access roads for the project. |

| Project Activity/ Impact Source | Environmental Impacts | Mitigation Measures/ Management Guidelines |
|------------------------------------|---|---|
| | material/equipment for erection parked outside on main road and unloading operations at main road | <ul style="list-style-type: none"> • Demarcate a designated loading/unloading area for the above category • Designate the delivery times to particular time of day and any night deliveries should not be encouraged. |

ECP 16: Construction Site and Labor Camp Management

| Project Activity/ Impact Source | Environmental Impacts | Mitigation Measures/ Management Guidelines |
|---|--|---|
| Siting and location of construction camps | Labor campsites for construction workers can impact health and safety and disrupt nearby communities. | <p>The Contractor will</p> <ul style="list-style-type: none"> • Prepare a construction camp management plan and submit the plan for PIU and PIAC approval. • Build the construction camps within the designed construction sites or at areas which are acceptable from environmental, cultural or social point of view; and approved by the PIU and PIAC. • Consider the location of construction camps away from communities in order to avoid social conflict in using the natural resources such as water or to avoid the possible adverse impacts of the construction camps on the surrounding communities. • Submit to the PIU and PIAC for approval a detailed layout plan for the development of the construction camp showing the relative locations of all temporary buildings and facilities that are to be constructed together with the location of site roads, fuel storage areas (for use in power supply generators), solid waste management and dumping locations, and drainage facilities, prior to the development of the construction camps. • Local authorities responsible for health, conducting religious rituals and security will be duly informed on the set up of camp facilities to maintain effective surveillance over public health, social and security matters. |
| Construction Camp Facilities | Lack of proper infrastructure facilities, such as water supply and sanitation facilities will increase pressure on the local services and generate substandard living standards and health hazards for construction workers. | <p>Contractor will provide the following facilities in the campsites</p> <ul style="list-style-type: none"> • Adequate camps/housing for all workers. • Safe and reliable water supply, which should meet the national and WBG EHS guidelines. • Water supply from deep tube wells of 300 m depth. Drinking water to be chlorinated at source, and ensure presence of residual chlorine with 0.1 ~ 0.25 ppm as minimum after 30 minutes of chlorine contact time (WHO guideline). • Hygienic sanitary facilities and sewerage system. The toilets and domestic waste water will be collected through a common sewerage. Provide separate latrines and bathing places for males and females workers with total isolation by location. The minimum number of toilet facilities required is one toilet for every six persons. • Treatment facilities for sewerage of wastewater. • Storm water drainage facilities. Both sides of roads are to be provided with shallow v drains to drain off storm water to a silt retention pond which shall be sized to provide a minimum of 20 minutes retention |

| Project Activity/ Impact Source | Environmental Impacts | Mitigation Measures/ Management Guidelines |
|------------------------------------|---|---|
| | | <p>of storm water flow from the whole site. Channel all discharge from the silt retention pond to natural drainage via a grassed swale at least 20 meters in length with suitable longitudinal gradient.</p> <ul style="list-style-type: none"> • Paved internal roads. Ensure with grass/vegetation coverage to be made of the use of top soil that there is no dust generation from the loose/exposed sandy surface. Pave the internal roads of at least haring-bond bricks to suppress dusts and to work against possible muddy surface during monsoon. • Provide child crèches for women working construction site. The crèche shall have facilities for dormitory, kitchen, indoor and outdoor play area. Schools shall be attached to these crèches so that children are not deprived of education whose mothers are construction workers • Provide in-house community/common entertainment facilities. dependence of local entertainment outlets by the construction camps to be discouraged/prohibited to the extent possible. • Labor Camp will be constructed by maintaining all the safety issues of DG Health, Bangladesh |
| Disposal of waste | Management of wastes is crucial to minimize negative impacts on the environment | <p>The Contractor will</p> <ul style="list-style-type: none"> • Ensure the collection and disposal of solid wastes from the labor camps with disposal to suitably licensed waste management facilities • Insist on waste separation by source; organic wastes in one container and inorganic wastes in another container at household level. • Store inorganic wastes in a safe place within the household and clear organic wastes on a daily basis to waste collector. • Establish waste collection, transportation and disposal systems with the manpower and equipment/vehicles needed. • Dispose organic wastes in a covered storage container in a designated safe place on daily basis. Do not establish site specific landfill sites. Solid waste will be collected and removed from the work camps and disposed in approval waste disposal sites. |
| Fuel supplies for cooking purposes | Illegal sourcing of fuel wood by construction workers will impact the local flora and fauna | <p>The Contractor will</p> <ul style="list-style-type: none"> • Provide fuel to the construction camps for their domestic purpose, in order to discourage them to use fuel wood or other biomass. • Make available alternative fuels like natural gas or kerosene on ration to the workforce to prevent it from using biomass for cooking. |

| Project Activity/ Impact Source | Environmental Impacts | Mitigation Measures/ Management Guidelines |
|---------------------------------|---|--|
| | | <ul style="list-style-type: none"> • Conduct awareness campaigns to educate workers on preserving and protecting the biodiversity and wildlife of the project area, and relevant government regulations and enforcements on wildlife protection. |
| Health and Hygiene | <p>There will be a potential for diseases to be transmitted including malaria, exacerbated by inadequate health and safety practices. There will be an increased risk of construction workers spreading sexually transmitted infections and HIV/AIDS.</p> | <p>The Contractor will</p> <ul style="list-style-type: none"> • Provide adequate health care facilities within the construction sites. • Provide first aid facility round the clock. Maintain stock of medicines in the facility and appoint fulltime designated first aider or nurse. • Provide ambulance facility for the labors during emergency to be transported to nearest hospitals. • Carry out initial health screening of the labors coming from outside areas. • Train all construction workers in basic sanitation and health care issues and safety matters, and on the specific hazards of their work. • Provide HIV awareness programming, including STI (sexually transmitted infections) and HIV information, education and communication for all workers on a regular basis. • Provide complement educational interventions with easy access to condoms at campsites as well as voluntary counselling and testing • Provide adequate drainage facilities throughout the camps to ensure that disease vectors such as stagnant water bodies and puddles do not form anywhere near the site. • Regular mosquito repellent sprays (not pesticides subject to bans) are used during rainy season in offices and construction camps and yards. • Do not dispose food waste openly as that will attract rats, cockroaches and other insects, and stray dogs. • Carry out short training sessions on best hygiene practices to be mandatorily participated by all workers. • Place display boards at strategic locations within the camps containing messages on best hygienic practices. |
| Safety | <p>Inadequate safety facilities to the construction camps may create security problems and fire hazards</p> | <p>The Contractor will</p> <ul style="list-style-type: none"> • Provide appropriate security personnel (police or private security guards) and enclosures to prevent unauthorized entry into the camp area. • Maintain a register to keep a track on a head count of persons present in the camp at any given time. • Use flameproof material for the construction of labor housing / site office. Also, ensure that these |

| Project Activity/ Impact Source | Environmental Impacts | Mitigation Measures/ Management Guidelines |
|---------------------------------|--|---|
| | | <p>houses/rooms are of sound construction and capable of withstanding wind storms/cyclones.</p> <ul style="list-style-type: none"> • Provide firefighting equipment at the labor camps • Display emergency contact numbers clearly and prominently at strategic places in camps. • Communicate the roles and responsibilities of labourers in case of emergency in the monthly meetings with contractors. |
| Site Restoration | Restoration of the construction camps to original condition requires demolition of construction camps. | <p>The Contractor will</p> <ul style="list-style-type: none"> • Dismantle and remove from the site all facilities established within the construction camp including the perimeter fence and lockable gates at the completion of the construction work. • Dismantle camps in phases as certain work gets done/decreased and not wait for the entire work to be completed. • Give prior notice to the labourers before demolishing their camps/units. • Maintain the noise levels within the applicable noise levels during demolition activities. • Different subcontractors must be hired to demolish different structures to promote recycling or reuse of demolished materials. • Reuse the demolition debris to a maximum extent. • Dispose remaining debris at the suitably licensed waste management facility. • Restore the site to its condition prior to commencement of the works or to an agreed condition with the landowner. |

ECP 17: Cultural and Religious Issues

| Project Activity/ | Environmental Impacts | Mitigation Measures/ Management Guidelines |
|---|---|--|
| Construction activities near religious and cultural sites | Disturbance from construction works to the cultural, religious and educational sites, and construction workers lack of knowledge on cultural issues causes social disturbances. | <p>The Contractor will</p> <ul style="list-style-type: none"> • Communicate to the public through community consultation regarding the scope and schedule of construction, as well as certain construction activities causing disruptions or access restriction. • Not block access to cultural and religious sites, wherever possible. • Restrict all construction activities to within the footprints of the construction sites. • Stop construction works that produce noise (particularly during prayer time and school hours) if there are any mosque/religious/educational institutions close to the construction sites and users make objections. • Provide separate prayer facilities to the construction workers. • Allow the workers to participate in praying during construction time. • Show appropriate and decent behavior with all construction workers especially women and elderly people. • Resolve cultural issues in consultation with local leaders, PIU and PIAC. • Establish a mechanism that allows local people to raise grievances arising from the construction process. • Inform the local authorities responsible for health, religious and security before commencement of construction works so as to maintain effective surveillance over public health, social and security matters. |
| Construction activities near archaeological, burial sites | Disturbance from construction works to the archaeological or burial sites and construction workers lack of knowledge on these issues causes social disturbances | <ul style="list-style-type: none"> • Take special care and use appropriate equipment when working next to cultural/religious institutions. • Develop a Chance Find Procedure for archaeological remains. This procedure will require stopping work immediately and notify the site manager if, during construction, an archaeological or burial site is discovered. It is an offence to recommence work in the vicinity of the site until approval to continue is given. • Stop work immediately and notify the site manager if, during construction, an archaeological or burial site is discovered. It is an offence to recommence work in the vicinity of the site until approval to continue is given by the PIAC/PMU. |
| Construction activity unearths any | Digging foundations of buildings electrical etc., | <ul style="list-style-type: none"> • If suspected physical cultural resources are encountered, all works at the find site should be immediately halted. |

| Project Activity/ | Environmental Impacts | Mitigation Measures/ Management Guidelines |
|---------------------------|--|--|
| physical cultural objects | infrastructure may unearth any physical cultural object that is protected by law | <ul style="list-style-type: none"> • The find should be assessed by a competent official of government, and procedures to avoid, minimize or mitigate impacts to such physical cultural objects should then be agreed in writing with them. • Work will not begin or resume until the procedures to avoid, minimize, or mitigate impacts to the physical cultural resources have been agreed and implemented in full. • If avoidance is not feasible, and no alternatives to removal exist, cost-benefit assessment needs to be carried out to assess whether the project works should continue or stop at site. If the project benefits outweigh the anticipated cultural heritage loss from removal which is unlikely unless in case of resource of local value, following clearance of NESCO and ADB, the physical cultural resources should be removed and preserved using the best available technique in accordance with relevant provisions of national heritage protection laws and decrees as well as international best archaeological practice. • Records to be maintained of all finds, including chain of custody instructions for movable finds. |

ECP 18: Worker's Health and Safety including Labor Accommodation

| Project Activity/ Impact Source | Environmental Impacts | Mitigation Measures/ Management Guidelines |
|---------------------------------|---|---|
| Best practices | Construction works may pose health and safety risks to the construction workers and site visitors leading to severe injuries and deaths. The population in the proximity of the construction site and the construction workers will be exposed to a number of (i) biophysical health risk factors, (e.g. noise, dust, chemicals, construction material, solid waste, waste water, vector transmitted diseases etc.), (ii) risk factors resulting from human behavior (e.g. STD, HIV etc.) and (iii) road accidents from construction traffic. | <p>The Contractor will</p> <ul style="list-style-type: none"> • Prepare an Occupational Health and Safety plan and submit the plan for PIU and PIAC approval. • Implement suitable safety standards for all workers and site visitors which must not be less than those laid down in international good practice guidelines (e.g., International Labor Organization guideline on 'Safety and Health in Construction; World Bank Group's 'Environmental Health and Safety Guidelines') and the contractor's own national standards or statutory regulations, in addition to complying with national requirements. • Appoint an environment, health and safety manager to look after the health and safety of the workers. • Provide the workers with a safe and healthy work environment, considering inherent risks in its particular construction activity and specific classes of hazards in the work areas. • Provide personal protection equipment (PPE) for workers, such as safety boots, helmets, masks, gloves, protective clothing, goggles, full-face eye shields, and ear protection. Maintain the PPE properly by cleaning dirty ones and replacing the damaged ones. • Safety procedures to include provision of information, training and protective clothing to workers involved in hazardous operations and ensuring safe performance in their job. • Inform the local authorities responsible for health, religious rituals and security before commencement of construction works and establishment of labor camps so as to maintain effective surveillance over public health, social and security matters. |
| | Child and pregnant labor | The Contractor shall not hire children of less than 14 years of age and pregnant women or women who delivered a child within 8 preceding weeks, in accordance with the Bangladesh Labor Code, 2006 |
| Incident Management | Lack of first aid facilities and health care facilities in the | <p>The Contractor will</p> <ul style="list-style-type: none"> • Ensure health care facilities and first aid facilities are readily available; appropriately equipped first-aid stations to be easily accessible throughout the place of work. |

| Project Activity/ Impact Source | Environmental Impacts | Mitigation Measures/ Management Guidelines |
|---|--|---|
| | immediate vicinity will aggravate the health conditions of the victims | <ul style="list-style-type: none"> • Prevent accidents, injury, and disease arising from, associated with, or occurring in the course of work by minimizing, as far as reasonably practicable, the causes of hazards, in a manner consistent with good international industry practice. • Identify potential hazards to workers, particularly those that may be life-threatening and provide necessary preventive and protective measures. • Document and report occupational accidents, diseases, and incidents. • Provide awareness raising to the construction drivers to strictly follow the driving rules. • Provide adequate lighting in the construction area. |
| Construction Camps | Lack of proper infrastructure facilities, such as water supply and sanitation facilities will increase pressure on the local services and generate substandard living standards and health hazards for construction workers. | <p>The Contractor will provide the following facilities in the labor campsites or other accommodation being provided to improve health and hygienic conditions as mentioned in ECP 16</p> <p>Construction Camp Management</p> <ul style="list-style-type: none"> • Adequate ventilation facilities • Safe and reliable water supply meeting drinking water standards • Hygienic sanitary facilities and sewerage system. • Treatment facilities for sewerage • Storm water drainage facilities. • Safe storage facilities for petroleum and other chemicals in accordance with ECP 2 • Solid waste collection and disposal system in accordance with ECP1. • Arrangements for trainings • Recreational and social facilities • Sick bay and first aid facilities • Paved internal roads. • Security fence at least 2 m height. |
| Water and sanitation facilities at the construction sites | Lack of water and sanitation facilities at construction sites causes inconvenience to the construction workers and affects their personal hygiene. | <p>The Contractor will</p> <ul style="list-style-type: none"> • Provide portable toilets at construction sites. • The location of portable toilets should be at least 6 m away from the storm drain system and surface waters. • Portable toilets must be cleaned once a day and all the sewerage pumped from the collection tank once a day and brought to a common septic tank for further treatment. • Provide safe and reliable drinking water facilities meeting drinking water standards to the construction workers at all the construction sites and accommodation provided for them |
| Other ECPs | Potential risks to health of construction | <p>The Contractor will follow the following ECPs to reduce health risks to the construction workers and nearby communities</p> <ul style="list-style-type: none"> • ECP 2: Fuels, Oils and Other Hazardous Substances Management |

| Project Activity/ Impact Source | Environmental Impacts | Mitigation Measures/ Management Guidelines |
|---|---|--|
| | workers (and general public) | <ul style="list-style-type: none"> • ECP 4: Drainage Management • ECP 10: Air Quality Management • ECP 11: Noise and Vibration Management • ECP 15: Road Transport and Road Traffic Management |
| Training and Awareness Raising | Lack of awareness and basic knowledge in health and safety among the construction workforce, increases the risk of an incident or contracting of diseases | <p>The Contractor will</p> <ul style="list-style-type: none"> • Train all construction workers in general health and safety matters, and on the specific hazards of their work. Training should consist of basic hazard awareness, site specific hazard awareness, safe work practices, and emergency procedures for fire, natural hazards, and evacuation, as appropriate. • Train all construction workers in basic sanitation and health care issues (e.g., hand washing etc.) • Implement communicable disease including malaria, HIV/AIDS and STI education campaign targeting all workers hired by contractor and subcontractors, international and national, female and male, skilled, semi- and unskilled occupations, at the time of recruitment and thereafter pursued throughout the construction phase on an ongoing and regular basis. This should be complemented by easy access to condoms at the workplace as well as to voluntary counselling and testing. |
| PPE requirements to based on Job Hazard Analysis for the specific work that is to be performed. | Proper PPE availability and training on how to use them are important for workers to ensure their H&S during work | <p>General PPE Instructions: Inspect all PPE prior to use to ensure it is safe, properly assembled and not visibly defective. Personal Protective Equipment (PPE) shall be maintained in a sanitary and reliable condition. Damaged or otherwise unserviceable PPE shall be properly disposed of and replaced. Personnel shall be trained and must demonstrate that they understand the following:</p> <ul style="list-style-type: none"> • When PPE is necessary • What PPE is necessary • How to properly adjust, wear and use PPE • The limitations of the PPE • The care, maintenance, useful life, and disposal of PPE. <p>Minimum PPE Requirements: Minimum PPE requirements are usually established for routine work such as site tours and visual inspections. These minimum requirements are:</p> <ul style="list-style-type: none"> • Hard Hat • Safety Glasses • Safety Shoes –Safety Toed with Electrical rated soles preferred • Work Clothing – No shorts, sweatpants or sleeveless shirts allowed. Long pants and work type shirt (long or short sleeved). Site Technicians are required to wear Arc Rated clothing as part of their regular work uniform (HRC 2 or >8.1 cal/cm²) • Work Gloves – Leather, shall be carried if there is a |

| | | |
|---|--|--|
| | | <p>possibility of material handling.</p> <ul style="list-style-type: none"> • Based on the job you are performing additional PPE may be required. Additional PPE may include: <ul style="list-style-type: none"> ○ Arc Rated (FR) Clothing – Arc rating is based on Arc Hazard Analysis and is typically identified on Equipment Arc Flash Hazard Labels. Clothing may include shirt and pants or could include higher rated Arc Flash Suits ○ Arc Flash Face Shield – Arc Flash Face Shields are required where hazards are HRC 2 or above ○ Hearing Protection – For areas posted as greater than 80dB or where noise levels make it difficult to hear another worker speaking ○ Safety Vest – To improve visibility ○ Kevlar or cut resistant gloves – For glass handling activities ○ Protective Chemical Clothing – If exposed to or handling chemicals ○ Insulated gloves for electrical work. <p>NESCO will provide PPE including, hard hats, safety eyeglasses, hearing protection, and work gloves.</p> <ul style="list-style-type: none"> • Work Clothing: Arc Flash Clothing including a shirt covering the shoulders and trousers covering the legs and ankles shall be always worn when working on or near energized electrical equipment. • Arms—When working in the vicinity of energized lines or equipment (both high and low voltage), on high temperature lines, grinding, welding, or other high exposure hazards to the arm, full-length sleeves shall be worn. • Legs—Workers should not have cuffs on trousers when welding or performing any job that produces sparks. |
| <p>Risks to the health and safety of workers prevented by provision of suitable PPE</p> | <p>Risk to workers without proper PPE at each site for all tasks to be performed..</p> | <p>Personnel Protective Equipment. Personal Protective Equipment (PPEs) like safety gloves, helmet, mufflers etc. will be provided during the construction period and during the maintenance work. Depending on the nature of work and the risks involved, contractors must provide without any cost to the workers, the following protective equipment.</p> <ul style="list-style-type: none"> • Helmet shall be provided to all workers, or visitors visiting the site, for protection of the head against impact or penetration of falling or flying objects. • All PPE must be of good quality with mark of quality standard certification. • Safety belt shall be provided to workers working at heights for bridge construction, etc. • Safety boots shall be provided to all workers for protection of feet from impact or penetration of falling objects on feet. • Ear protecting/ earmuffs/plugs shall be provided to all workers in high noise zones. (vi) Eye and face protection equipment shall be provided to all welders to protect against sparks. |

| | | |
|--|--|---|
| | | <ul style="list-style-type: none"> • Respiratory protection devices shall be provided to all workers during occurrence of fumes, dusts, or toxic gas/vapor. • The supervisor must ensure that appropriate personal protective equipment is available to workers; properly worn when required and properly cleaned, inspected, maintained, and stored. • A worker shall be responsible for using the items of personal protective equipment provided by the employer; • A worker who is required to use personal protective equipment must- <ul style="list-style-type: none"> ○ Use the equipment in accordance with training and instruction. ○ Inspect the equipment before use. ○ Refrain from wearing protective equipment outside of the work area which if done so would constitute a hazard; and ○ Report any equipment malfunction to the supervisor or employer. • A worker who is assigned responsibility for cleaning, maintaining, or storing personal protective equipment must do so in accordance with training and instruction provided. • The safety and emergency procedures manual will be kept. Necessary training regarding the safety aspects of the personnel working at the project site will be provided. • First aid facilities will be made available, and doctors called in from nearby village/towns when necessary. Contents of the First aid box is given in Table below |
|--|--|---|

Personal Protective Equipment for Safety of Different Body Parts

Recommended Personal Protective Equipment According to Workplace Hazards

| No | Objective | Workplace Hazard | PPE |
|----|-------------------------|--|---|
| 1. | Eye and Face Protection | Flying particles, Molten metal, Liquid chemicals, gases, vapor. | Safety glasses with side-shields, protective shades, etc. |
| 2 | Head Protection | Falling objects, inadequate height clearance, and overhead power cords | Plastic helmets with top and side impact protection. |
| 3 | Hearing Protection | Noise | Hearing protectors (ear plugs or ear muffs) |
| 4 | Foot Protection | Falling or rolling objects, pointed objects, corrosive or hot liquids | Safety shoes and boots for protection against moving & falling objects, liquids and chemicals. |
| 5 | Hand Protection | Hazardous materials, cuts or lacerations, vibrations, extreme temperatures | Gloves made of rubber or synthetic materials (Neoprene), leather, steel, insulating materials, etc. |
| 6 | Respiratory Protection | Dust, fogs, fumes, mists, gases, smokes, vapours | Facemasks with appropriate filters for dust removal and air purification (chemicals, mists, vapor and gases). |
| 7 | Body/leg Protection | Extreme temperatures, hazardous materials, cutting and laceration. | Insulating clothing, body suits, aprons, etc of appropriate materials. |

Recommended contents of First Aid Kit According to Workplace Hazards

| Sr. No. | Description | Quantity |
|---------|---|------------|
| 1 | First aid leaflet | 1 copy |
| 2 | Sterilized finger dressing | 10 nos. |
| 3 | Sterilized hand or foot dressing | 10 nos. |
| 4 | Sterilized body or large dressing | 6 nos. |
| 5 | Sterilized burns dressing – small | 4 nos. |
| 6 | Sterilized burns dressing – large | 2 nos. |
| 7 | Sterilized burns dressing – extra large | 6 nos. |
| 8 | Sterilized cotton wool (25 gms) | 2 tubes |
| 9 | Cetavolon | 2 tubes |
| 10 | Eye pads | 6 nos. |
| 11 | Adhesive plaster | 1 spool |
| 12 | Assorted roller bandage | 6 nos. |
| 13 | Triangular bandages | 6 nos. |
| 14 | Safety pins | 6 nos. |
| 15 | Scissors, ordinary, 12.7cms, both sides sharp | 1 pair |
| 16 | Antiseptic liquid, 150 ml, or equivalent | 2 nos. |
| 17 | Cotton wool for padding, 100 gms | 2 packets |
| 18 | Eye Ointment of sulphacetamide preparation | 1 tube |
| 19 | Loose woven gauze (28"x8"), compressed pack | 1 packet |
| 20 | Aspirin, 300 mg (10 tablets) | 5 strips |
| 21 | Note Pad, with a pencil in a plastic cover | 1 no. |
| 22 | Adhesive dressing strips | 10 strips |
| 23 | Field dressing of modified army pattern | 3 nos. |
| 24 | Record cards in a plastic cover | 1 set |
| 25 | Torch, medium size | 1 no. |
| 26 | Eye wash | 1 no. |
| 27 | Wooden splints, small | 1 set |
| 28 | Wooden splints, big | 1 set |
| 29 | Disinfectant, Spirt, 100ml | 1 bottle |
| 30 | Oral rehydration salts | 10 packets |

| | | |
|--|--|--|
| <p>Emergency preparedness and response plan tailored to the hazards associated with the project such as spills, leaks etc.</p> | <p>Delay in response in the event of a leak, spill, release, or other emergency to adverse environmental impacts</p> | <p>The contractor should conduct/prepare:</p> <ul style="list-style-type: none"> • SOP for the management of containment structures, specifically the removal of any accumulated fluid, such as rainfall, to ensure that the intent of the system is not accidentally or wilfully defeated • Implementation plan of inspection programs to ensure containment structures are physically intact and being well managed • Identification plan of locations of hazardous materials and associated activities on an emergency plan • Documentation of availability of specific personal protective equipment and training needed to respond to an emergency • Documentation of availability of spill response equipment sufficient to handle at least initial stages of a spill and a list of external resources for equipment and personnel, if necessary, to supplement internal resources • Description of response activities in the event of a leak, spill, release, or other emergency including internal and external notification procedures, specific responsibilities of individuals, decision process for |
|--|--|--|

| | | |
|--|--|--|
| | | <p>assessing severity of the incident and determining appropriate action, first aid and emergency medical treatment, evacuation routes, post- event activities such as clean-up and disposal, incident investigation, worker re-entry, and replenishment of used PPE and spill response equipment</p> <ul style="list-style-type: none">• Inspecting, testing, and maintaining the emergency response equipment• Training of workers on release prevention, including drills specific to hazardous materials stored on site |
|--|--|--|

