

গণপ্রজাতন্ত্রী বাংলাদেশ সরকার
পেটেন্ট, শিল্প-নকশা ও ট্রেডমার্কস অধিদপ্তর
শিল্প মন্ত্রণালয়
৯১, মতিঝিল বা/এ, ঢাকা-১০০০
www.dpdt.gov.bd

নং-৩৬.০৮.০০০০.২০০.১৬.০০১.২২. ৬৬৩

তারিখঃ ২১/৬/২০২৬ খ্রি.

বিষয়ঃ দাখিলকৃত পেটেন্ট আবেদনসমূহ ওয়েবসাইটে প্রকাশ।

বাংলাদেশ পেটেন্ট আইন, ২০২৩ এর ধারা ১৭ অনুযায়ী ডিপিডিটিতে ২০২৪ সালে দাখিলকৃত পেটেন্ট আবেদন নং ২৬২-২৬৩, ২৬৫-২৬৮, ২৭০-২৮২, ২৮৫-২৯২, ২৯৪-৩০১, ৩০৩-৩০৫, ৩০৭-৩২৭, ৩২৯-৩৪২, ৩৪৪-৩৪৬, ৩৪৮-৩৫২, ৩৫৪ মোট ৮২ (বিরাশি) টি আবেদন নিম্নবর্ণিত তথ্যাদি সহ অধিদপ্তরের ওয়েবসাইটে (www.dpdt.gov.bd) প্রকাশ করা হল।

- (ক) উদ্ভাবনের শিরোনাম;
- (খ) পেটেন্ট আবেদনকারী ও উদ্ভাবকের নাম;
- (গ) আবেদন দাখিলের তারিখ ও নম্বর;
- (ঘ) অগ্রাধিকার নম্বর ও তারিখ, যদি থাকে;
- (ঙ) পেটেন্ট এর শ্রেণিবিন্যাস;
- (চ) উদ্ভাবনের মূল উপাদান চিত্রায়িত করে এইরূপ অংকন, যদি থাকে;
- (ছ) বিষয়বস্তুর সার-সংক্ষেপ।

সংযুক্তিঃ ৮২ (বিরাশি) পাতা।

২১/০৬/২৬
মোঃ হাবিবুর রহমান
উপ-পরিচালক (পেটেন্ট)

অনুলিপিঃ

- ১। পরিচালক (সকল), পেটেন্ট, শিল্প-নকশা ও ট্রেডমার্কস অধিদপ্তর, ঢাকা।
- ২। সিস্টেম এনালিস্ট, পেটেন্ট, শিল্প-নকশা ও ট্রেডমার্কস অধিদপ্তর। (ওয়েবসাইটে প্রকাশের জন্য)
- ৩। উপ-পরিচালক (পেটেন্ট) (সকল), পেটেন্ট, শিল্প-নকশা ও ট্রেডমার্কস অধিদপ্তর, ঢাকা।
- ৪। মহাপরিচালক মহোদয়ের ব্যক্তিগত সহকারী, পেটেন্ট, শিল্প-নকশা ও ট্রেডমার্কস অধিদপ্তর, ঢাকা।



গণপ্রজাতন্ত্রী বাংলাদেশ সরকার
পেটেন্ট, শিল্প-নকশা ও ট্রেডমার্কস অধিদপ্তর
শিল্প মন্ত্রণালয়
৯১, মতিঝিল বা/এ, ঢাকা-১০০০
www.dpdt.gov.bd

Publication of Filed Patent Application
Publication No: 33 & Date: 21 June 2026

(11) Patent registration No and date , (21) Appl. No. BD-P-2024-262 (22) Filed: 01/09/2024	
(23) Priority Data: European Patent Office (EPO), Number :231956772, Date : 06-09-2023.	
(71) Applicant: SICPA HOLDING SA of Avenue de Florissant 41 1008 Prilly, Nationality -Switzerland	
(72) Inventors: (1) ESPINOSA David of Chemin Champ du clos 14, 1418 Vuarrens, Switzerland Nationality - Switzerland, (2) MARTINI Thibaut of Route du Stand 60, 1260 Nyon, Switzerland Nationality -France, (3) RUGGERONE Riccardo of Chemin du Marais 3, 1040 Echallens, Switzerland Nationality -Italy, (4) MOLINA Aldric of Rue du Bicentenaire 6b, 1304 Cossonay, Switzerland Nationality -Switzerland	
(74) Agent : Advanced IP Law Firm, Suite#9/C (9th Floor), Fahima Tower, 42-43, Purana Paltan, Dhaka-1000, Bangladesh	
(51) INT. CL. : B42D 25/378	
(54) Invention Title: UV-VIS CURABLE SECURITY INKS COMPRISING TAGS AND SECURITY FEATURES OBTAINED THEREOF	
(57) Abstract The present invention relates to the technical field of security features comprising taggants by means of Surface-Enhanced Raman Spectroscopy (SERS) and their detection. Furthermore, the present invention relates to the field of UV-Vis curable security inks comprising SERS tags for printing security features on substrates, in particular on security documents or articles, wherein said inks comprise i) one or more surface enhanced Raman spectroscopy (SERS) tags, ii) one or more vinyl ether containing compounds, iii) one or more cationically radiation curable compounds different from the one or more vinyl ether containing compounds of ii) and iv) one or more cationic photoinitiators being a salt of hexafluorophosphate.	



গণপ্রজাতন্ত্রী বাংলাদেশ সরকার
পেটেন্ট, শিল্প-নকশা ও ট্রেডমার্কস অধিদপ্তর
শিল্প মন্ত্রণালয়
৯১, মতিঝিল বা/এ, ঢাকা-১০০০
www.dpdt.gov.bd

Publication of Filed Patent Application
Publication No: 33 & Date: 21 June 2026

(11) Patent registration No and date , (21) Appl. No. BD-P-2024-263 (22) Filed: 01/09/2024	
(23) Priority Data: European Patent Office (EPO), Number :231956780, Date : 06-09-2023.	
(71) Applicant: SICPA HOLDING SA of Avenue de Florissant 41 1008 Prilly, Nationality -Switzerland	
(72) Inventors: (1) ESPINOSA David of Chemin Champ du clos 14, 1418 Vuarrens, Switzerland Nationality - Switzerland, (2) MARTINI Thibaut of Route du Stand 60, 1260 Nyon, Switzerland Nationality -France, (3) MOLINA Aldric of Rue du Bicentenaire 6b, 1304 Cossonay, Switzerland Nationality -Switzerland, (4) PASQUIER Cécile of Impasse des Primevères 1, 1723 Marly , Switzerland Nationality -Switzerland, (5) YADEL Cindy of 207 Chemin des Hivouettes, 01170 Crozet, France Nationality -France, (6) ROD Coraline of Route Dessous-la-Ville 6, 1305 Penthalaz, Switzerland Nationality -Switzerland	
(74) Agent : Advanced IP Law Firm, Suite#9/C (9th Floor), Fahima Tower, 42-43, Purana Paltan, Dhaka-1000, Bangladesh	
(51) INT. CL. : B41M 3/14	
(54) Invention Title: UV-VIS CURABLE SECURITY INKS COMPRISING TAGS AND SECURITY FEATURES OBTAINED THEREOF	
(57) Abstract The present invention relates to the technical field of security features comprising taggants by means of Surface-Enhanced Raman Spectroscopy (SERS) and their detection. Furthermore, the present invention relates to the field of UV-Vis curable security inks comprising SERS tags for printing security features on substrates, in particular on security documents or articles, wherein said inks comprise one or more surface enhanced Raman spectroscopy (SERS) tags, one or more radiation curable compounds, and one or more photoinitiators and wherein said inks lack a vinyl ether containing compound.	



গণপ্রজাতন্ত্রী বাংলাদেশ সরকার
পেটেন্ট, শিল্প-নকশা ও ট্রেডমার্কস অধিদপ্তর
শিল্প মন্ত্রণালয়
৯১, মতিঝিল বা/এ, ঢাকা-১০০০
www.dpdt.gov.bd

Publication of Filed Patent Application
Publication No: 33 & Date: 21 June 2026

(11) Patent registration No and date , (21) Appl. No. BD-P-2024-265 (22) Filed: 05/09/2024
(23) Priority Data: N/A
(71) Applicant: Bangladesh Machine Tools Factory Ltd. of Joydebpur, Gazipur-1700 , Nationality -Bangladesh
(72) Inventors: (1) Maj Shahidollah Tareq, psc, AC of Deputy General Manager, Bangladesh Machine Tools Factory, Joydebpur, Gazipur - 1700, Bangladesh Nationality -Bangladesh
(51) INT. CL. : B60L 9/00
(54) Invention Title: Solar Powered Three Wheeled Electric Vehicle
(57) Abstract The present invention relates to a solar powered three wheeled electric vehicle, particularly designed for use in the agricultural sector, especially by marginal farmers. The vehicle comprises a frame, an electric motor, a battery pack, a control system, a cargo platform, a display section, and a solar panel system. The solar panel system charges the battery pack, extending the vehicle's range and reducing reliance on external charging infrastructure. The vehicle, equipped with a cargo platform and a display section, allows for both carrying and selling goods resulting in benefits for the farmer.

Fig 01: Front view of the solar powered three wheeled electric vehicle



গণপ্রজাতন্ত্রী বাংলাদেশ সরকার
পেটেন্ট, শিল্প-নকশা ও ট্রেডমার্কস অধিদপ্তর
শিল্প মন্ত্রণালয়
৯১, মতিঝিল বা/এ, ঢাকা-১০০০
www.dpdt.gov.bd

Publication of Filed Patent Application
Publication No: 33 & Date: 21 June 2026

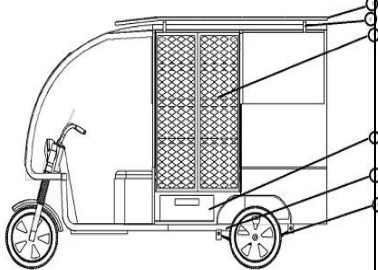
(11) Patent registration No and date , (21) Appl. No. BD-P-2024-266 (22) Filed: 05/09/2024
(23) Priority Data: India, Number :202341059500, Date : 05-09-2023.
(71) Applicant: TVS Motor Company Limited of “Chaitanya”, No.12 Khader Nawaz Khan Road, Nungambakkam, Chennai 600 006, Tamil Nadu, Nationality -India
(72) Inventors: (1) GUTTI GNANAKOTAIAH of “Chaitanya”, No.12 Khader Nawaz Khan Road, Nungambakkam, Chennai 600 006, Tamil Nadu, India Nationality -India, (2) KUPPUSAMY LOGANATHAN of “Chaitanya”, No.12 Khader Nawaz Khan Road, Nungambakkam, Chennai 600 006, Tamil Nadu, India Nationality -India, (3) HARIPRASAD SOUNDARRAJAN of “Chaitanya”, No.12 Khader Nawaz Khan Road, Nungambakkam, Chennai 600 006, Tamil Nadu, India Nationality -India, (4) SURENDRAN PRASANNA RAJESH of “Chaitanya”, No.12 Khader Nawaz Khan Road, Nungambakkam, Chennai 600 006, Tamil Nadu, India Nationality -India, (5) MYSORE KRISHNAMOORTHY AJAYKUMAR of “Chaitanya”, No.12 Khader Nawaz Khan Road, Nungambakkam, Chennai 600 006, Tamil Nadu, India Nationality -India
(74) Agent : Rana & Associates, Nipobon Asgar Garden, 462, Green Way, Flat No. A/2, (2nd Floor), Moghbazar, Dhaka-1217, Bangladesh
(51) INT. CL. : B60R 21/213
(54) Invention Title: A MOUNTING ASSEMBLY FOR MOUNTING A RESERVOIR MEMBER OF A VEHICLE
(57) Abstract The present invention relates to a mounting assembly (200) for mounting a reservoir member (400) over a frame assembly (101) of a vehicle (100). The mounting assembly (200) comprises a plurality of first mounting members (201), and one or more second mounting members (300). The plurality of first mounting members (201) supports the reservoir member (400) from a first side and the one or more second mounting members (300) support from a second side. The present invention further relates to the second mounting member (300) for mounting a reservoir member (400). The second mounting member (300) comprises a top side (301) and a vertical side (302). The present invention also relates to a vehicle (100) comprising the frame assembly (101), a prime mover (102), a cover body (103), and the mounting assembly (200) for mounting the reservoir member (400).

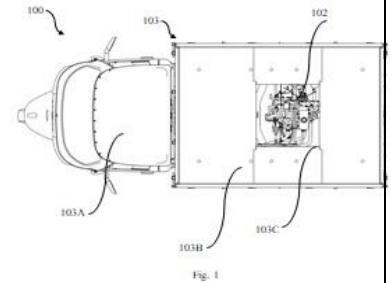



গণপ্রজাতন্ত্রী বাংলাদেশ সরকার
পেটেন্ট, শিল্প-নকশা ও ট্রেডমার্কস অধিদপ্তর
শিল্প মন্ত্রণালয়
৯১, মতিঝিল বা/এ, ঢাকা-১০০০
www.dpdt.gov.bd

Publication of Filed Patent Application
Publication No: 33 & Date: 21 June 2026

(11) Patent registration No and date , (21) Appl. No. BD-P-2024-267 (22) Filed: 09/09/2024
(23) Priority Data: United Kingdom, Number :23165509, Date : 30-10-2023.
(71) Applicant: Nokia Technologies Oy of Karakaari 7, 02610 Espoo, Nationality -Finland
(72) Inventors: (1) Ugur Baran ELMALI of Eisnergutbogen 54, Munich, 80639, Germany Nationality -Turkey, (2) Philippe GODIN of 20 rue de la Chaumiere, Versailles, 78000, France Nationality -France, (3) Bighnaraj PANIGRAHI of 301, Maruthi Homes Apartment, Hagadur Main Road, Whitefield, Bangalore, 560005, India Nationality -India, (4) Horst Thomas BELLING of Gleiwitzerstr. 25, Erding, 85435, Germany Nationality -Germany
(74) Agent : REMFRY & SON LIMITED, 56, NEW ESKATON ROAD 4TH FLOOR, DHAKA-1000, DHAKA, Bangladesh
(51) INT. CL. : H04L 65/611
(54) Invention Title: FREQUENCY PRIORITIZATION FOR TERMINAL DEVICES RECEIVING A MULTICAST BROADCAST SERVICE
(57) Abstract According to an aspect, there is provided an apparatus configured to perform the following. The apparatus receives a service announcement of a multicast broadcast service. The apparatus receives, in the service announcement and/or in at least one message following the service announcement, at least one indication indicating support for all or at least some reduced capability terminal devices for the multicast broadcast service. The apparatus performs a cell reselection process based on cell measurements and the at least one indication.
<p>Fig. 1</p> <p>Fig. 2</p> <p>Fig. 3</p>



গণপ্রজাতন্ত্রী বাংলাদেশ সরকার
 পেটেন্ট, শিল্প-নকশা ও ট্রেডমার্কস অধিদপ্তর
 শিল্প মন্ত্রণালয়
 ৯১, মতিঝিল বা/এ, ঢাকা-১০০০
www.dpdt.gov.bd

**Publication of Filed Patent Application
 Publication No: 33 & Date: 21 June 2026**

(11) Patent registration No and date , (21) Appl. No. BD-P-2024-268 (22) Filed: 09/09/2024	
(23) Priority Data: United Kingdom, Number :23165467, Date : 30-10-2023.	
(71) Applicant: Nokia Technologies Oy of Karakaari 7, 02610 Espoo, Nationality -Finland	
(72) Inventors: (1) Ugur Baran ELMALI of Eisnergutbogen 54, Munich, 80639, Germany Nationality -Turkey, (2) Philippe GODIN of 20 rue de la Chaumiere, Versailles, 78000, France Nationality -France, (3) Bighnaraj PANIGRAHI of 301, Maruthi Homes Apartment, Hagadur Main Road, Whitefield, Bangalore, 560005, India Nationality -India, (4) Horst Thomas BELLING of Gleiwitzerstr. 25, Erding, 85435, Germany Nationality -Germany	
(74) Agent : REMFRY & SON LIMITED, 56, NEW ESKATON ROAD 4TH FLOOR, DHAKA-1000, DHAKA, Bangladesh	
(51) INT. CL. : H04L 65/611	
(54) Invention Title: FREQUENCY PRIORITIZATION FOR TERMINAL DEVICES RECEIVING A MULTICAST BROADCAST SERVICE	
(57) Abstract <p>According to an aspect, there is provided an apparatus configured to perform the following. The apparatus receives a service announcement of a multicast broadcast service. The service announcement comprises either at least one frequency selection area identity, FSAI, and at least one indication indicating that the at least one FSAI is defined for reduced capability terminal devices or at least one frequency and at least one indication indicating that the at least one frequency is defined for reduced capability terminal devices. The apparatus performs a cell reselection process based on cell measurements and the service announcement.</p>	<p>Fig. 1</p> <p>Fig. 2</p> <p>Fig. 3</p>



গণপ্রজাতন্ত্রী বাংলাদেশ সরকার
পেটেন্ট, শিল্প-নকশা ও ট্রেডমার্কস অধিদপ্তর
শিল্প মন্ত্রণালয়
৯১, মতিঝিল বা/এ, ঢাকা-১০০০
www.dpdt.gov.bd

Publication of Filed Patent Application
Publication No: 33 & Date: 21 June 2026

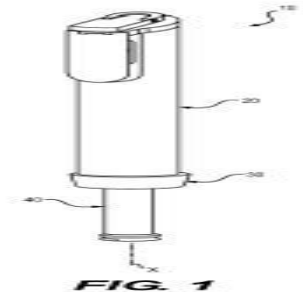
(11) Patent registration No and date , (21) Appl. No. BD-P-2024-270 (22) Filed: 11/09/2024	
(23) Priority Data: United States of America, Number :18244868, Date : 11-09-2023.	
(71) Applicant: INTEGRIMEDICAL LLC of 7862 N. Co. Rd. 100 East, Bainbridge IN 46105, Nationality -United States of America	
(72) Inventors: (1) Hassan Salari of c/o Integrimedical, LLC, 7862 N. Co. Rd. 100 East, Bainbridge IN 46105, United States of America Nationality -Canada, (2) Ankur Ramesh Naik of c/o Integrimedical, LLC, 7862 N. Co. Rd. 100 East, Bainbridge IN 46105, United States of America Nationality -India, (3) Sambath Kumar Rajagopal of c/o Integrimedical, LLC, 7862 N. Co. Rd. 100 East, Bainbridge IN 46105, United States of America Nationality -India	
(74) Agent : Shahid & Alliance, 30/3 B C Das Street, Lalbagh, Dhaka-1205, Bangladesh	
(51) INT. CL. : F02D 3/00	
(54) Invention Title: MEDICAL NEEDLE-FREE INJECTION SYSTEM AND METHOD	
(57) Abstract A spring-loadable fluid injection device for a needle-free syringe is provided and comprises a trigger positioned within the housing and actuated by depression of a push button or lever disposed opposite the dispensing end at an external actuation surface. The trigger has a trigger latch configured to release a trigger catch as heaving part of the spring-loaded piston of the device. The trigger catch is configured to urge the trigger latch in a direction transverse to the injection axis when the piston moves from the unloaded position to the loaded position. The compression spring is retained around the piston and retained within the housing by a piston head. The device further comprises a syringe adapter and a safety cap which prevents accidental triggering. An embodiment further includes a prefilled syringe adapter for aseptic filling of a needle-free syringe from a prefilled syringe.	



গণপ্রজাতন্ত্রী বাংলাদেশ সরকার
পেটেন্ট, শিল্প-নকশা ও ট্রেডমার্কস অধিদপ্তর
শিল্প মন্ত্রণালয়
৯১, মতিঝিল বা/এ, ঢাকা-১০০০
www.dpdt.gov.bd

Publication of Filed Patent Application
Publication No: 33 & Date: 21 June 2026

(11) Patent registration No and date , (21) Appl. No. BD-P-2024-271 (22) Filed: 12/09/2024	
(23) Priority Data: European Patent Office (EPO), Number :232109447, Date : 20-11-2023. and India, Number :202311062832, Date : 19-09-2023.	
(71) Applicant: Archroma (Switzerland) GmbH of Hardstrasse 1, 4133 Pratteln, Nationality -Switzerland	
(72) Inventors: (1) Meenal Mehra of S-4/116A, Old Mahavir Nagar, New Delhi-110018, India Nationality -India, (2) Sanooj Narayanan of 13/402, Vijay Park, Kasaravadavali, Ghodbunder road, Thane west, Maharashtra 400615, India Nationality -India, (3) Chaya M Thakkar Patel of 39, M.K. Building, 1st floor, 5th road, Khar (west), opposite Mohini tower, Mumbai - 400052, India Nationality -India, (4) Rishi Kumar of H. No. 2740, Street No. 3, Tehsil Pura, Amritsar - 143001, India Nationality -India, (5) Raja Kaliappan of 8/180A, Kanjana, Railway Station Road, Aralvoimoli - 629301, Kanyakumari District, Tamil Nadu, India Nationality -India	
(74) Agent : REMFRY & SON LIMITED, 56, NEW ESKATON ROAD 4TH FLOOR, DHAKA-1000, DHAKA, Bangladesh	
(51) INT. CL. : C09D 183/00	
(54) Invention Title: ORGANO-FUNCTIONAL SILICONE CROSSLINKER AND DURABLE FINISHING COMPOSITION FORMED THEREFROM.	
(57) Abstract The present invention relates to the field of copolymers suitable for textile, more particularly relates to copolymers suitable for textile end finishing products such as softeners. More particularly, the present invention relates to an organo-functional silicone copolymer which results from the polymerization of silicone monomers, trialkoxy silane monomers and amine compounds. The present invention also relates to a composition of said copolymers with other hydrophilic polymers and uses of said copolymers as well as their compositions.	<p>Figure 1: Example 1, 4, 7</p> <p>Figure 2: Example 1, 5, 8</p>



গণপ্রজাতন্ত্রী বাংলাদেশ সরকার
পেটেন্ট, শিল্প-নকশা ও ট্রেডমার্কস অধিদপ্তর
শিল্প মন্ত্রণালয়
৯১, মতিঝিল বা/এ, ঢাকা-১০০০
www.dpdt.gov.bd

Publication of Filed Patent Application
Publication No: 33 & Date: 21 June 2026

(11) Patent registration No and date , (21) Appl. No. BD-P-2024-272 (22) Filed: 12/09/2024
(23) Priority Data: India, Number :202341061938, Date : 14-09-2023.
(71) Applicant: LAKSHMI MACHINE WORKS LTD of Perianaickenpalayam, Coimbatore – 641020, Tamilnadu, Nationality -India
(72) Inventors: (1) JEGANATHAN PASUPATHY of Lakshmi Machine Works Limited Perianaickenpalayam, Coimbatore -641020, Tamilnadu, India Nationality -India, (2) SELVARAJ, SANTHOSH of Lakshmi Machine Works Limited Perianaickenpalayam, Coimbatore -641020, Tamilnadu, India Nationality -India
(74) Agent : REMFRY & SON LIMITED, 56, NEW ESKATON ROAD 4TH FLOOR, DHAKA-1000, DHAKA, Bangladesh
(51) INT. CL. : D01H 15/00
(54) Invention Title: A POSITIONING DEVICE FOR A PIECING UNIT OF A TEXTILE RING SPINNING MACHINE AND METHOD THEREOF.
(57) Abstract A positioning device (100) for a piecing unit (2) in a textile ring spinning machine (1) having a yarn breakage detecting sensor mounted for each spindle position. The positioning device (100) includes a sensing unit (6) and a reflector to detect the position of the piecing unit (2). The positioning device (100) also includes a control unit (5), configured to determine the distance to be travelled by the piecing unit (2) and align the piecing unit (2) with the spindle position containing the broken yarn for initiating a yarn piecing operation. The positioning device (100) is compatible with textile ring spinning machines (1) having an automatic piecing unit (2) and does not require additional construction for functioning.

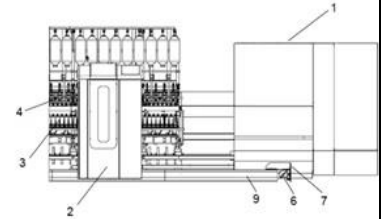
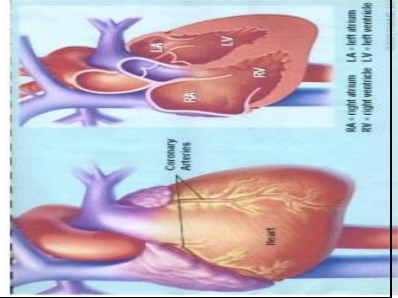

FIG. 1



গণপ্রজাতন্ত্রী বাংলাদেশ সরকার
পেটেন্ট, শিল্প-নকশা ও ট্রেডমার্কস অধিদপ্তর
শিল্প মন্ত্রণালয়
৯১, মতিঝিল বা/এ, ঢাকা-১০০০
www.dpdt.gov.bd

Publication of Filed Patent Application
Publication No: 33 & Date: 21 June 2026

(11) Patent registration No and date , (21) Appl. No. BD-P-2024-273 (22) Filed: 12/09/2024	
(23) Priority Data: N/A	
(71) Applicant: Dr. Md. Abdullah Al Mamun of Plot No: 3612, Road 11, Block-M, Bashundhara R/A, Vatara, Dhaka-1212, Nationality -Bangladesh	
(72) Inventors: (0) Dr. Md. Abdullah Al Mamun of Plot No: 3612, Road 11, Block-M, Bashundhara R/A, Vatara, Dhaka-1212, Bangladesh Nationality -Bangladesh	
(51) INT. CL. : G07F 17/34	
(54) Invention Title: DUEL MOTOR ARTIFICIAL HEART WITH ARTIFICIAL INTELLIGENCE AND SELF DIAGNOSIS SYSTEM POWERED BY NUCLEAR ENERGY	
(57) Abstract Artificial heart is going to be the final treatment for heart patient. Unique design, nuclear technology will ensure and the durability of this machine. Four turbine will be helpful for MI patients also. If we can provide this machine in cheap price it will change the history of medical science. Ai technology and Camera systems are also used in to make it most valuable products in the sector of human Cardiology.	



গণপ্রজাতন্ত্রী বাংলাদেশ সরকার
পেটেন্ট, শিল্প-নকশা ও ট্রেডমার্কস অধিদপ্তর
শিল্প মন্ত্রণালয়
৯১, মতিঝিল বা/এ, ঢাকা-১০০০
www.dpdt.gov.bd

Publication of Filed Patent Application
Publication No: 33 & Date: 21 June 2026

(11) Patent registration No and date , (21) Appl. No. BD-P-2024-274 (22) Filed: 15/09/2024
(23) Priority Data: China, Number :2023111877478, Date : 14-09-2023.
(71) Applicant: Xiamen Hongfa Electric Power Controls Co., Ltd. of No. 93 Yinong Road, Haicang District, Xiamen, Fujian 361027, Nationality -China
(72) Inventors:
(74) Agent : DOULAH & DOULAH , Doulah House (Annexe) Plot-153/2, Road-2/2, Block-A, Section-12, MIRPUR, DHAKA 1216, DHAKA, Bangladesh
(51) INT. CL. : F16K 31/06
(54) Invention Title: RELAY
(57) Abstract A relay includes a movable contact assembly (3100) comprising a movable contact piece (3110); a push rod assembly (3200) configured to push the movable contact assembly (3100) to move, to make the movable contact piece (3110) contact with or separate from a static contact leading-out terminal (2000); a limiting component (300) connected to the movable contact assembly (3100) and the push rod assembly (3200), and configured to restrict the movable contact assembly (3100) from rotating around an axis of the push rod assembly (3200) relative to the push rod assembly (3200); and an elastic assembly (3230) configured to provide a contact pressure.

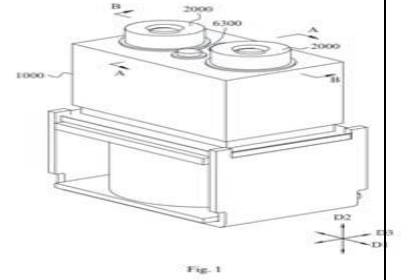



গণপ্রজাতন্ত্রী বাংলাদেশ সরকার
পেটেন্ট, শিল্প-নকশা ও ট্রেডমার্কস অধিদপ্তর
শিল্প মন্ত্রণালয়
৯১, মতিঝিল বা/এ, ঢাকা-১০০০
www.dpdt.gov.bd

Publication of Filed Patent Application
Publication No: 33 & Date: 21 June 2026

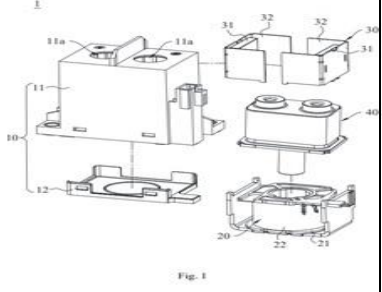
(11) Patent registration No and date , (21) Appl. No. BD-P-2024-275 (22) Filed: 15/09/2024
(23) Priority Data: China, Number :2023111876668, Date : 14-09-2023.
(71) Applicant: Xiamen Hongfa Electric Power Controls Co., Ltd. of No. 93 Yinong Road, Haicang District, Xiamen, Fujian 361027, Nationality -China
(72) Inventors:
(74) Agent : DOULAH & DOULAH, DOULAH HOUSE (ANNEX), PLOT-153/2, ROAD-2/2, BLOCK- A, SECTION-12, MIRPUR, DHAKA-1216, DHAKA, Bangladesh
(51) INT. CL. : F16K 31/06
(54) Invention Title: RELAY
(57) Abstract A relay includes a pair of static contact leading-out terminals (2000); movable contact pieces (3110), two ends of each of the movable contact pieces (3110) along a first direction (D1) is configured to contact with or separate from the pair of static contact leading-out terminals (2000); the first direction (D1) is an arrangement direction of the pair of static contact leading-out terminals (2000); wherein a contact gap between at least one of the movable contact pieces (3110) and the static contact leading-out terminal (2000) is smaller than contact gaps between remaining ones of the movable contact pieces (3110) and the static contact leading-out terminal (2000); and an anti-short circuit structure (6000) for forming suction forces on the movable contact pieces (3110) in a contact closing direction; wherein the suction force on the movable contact piece (3110) with a smaller contact gap is smaller than that on the remaining ones.
 <p>Fig. 1</p>



গণপ্রজাতন্ত্রী বাংলাদেশ সরকার
পেটেন্ট, শিল্প-নকশা ও ট্রেডমার্কস অধিদপ্তর
শিল্প মন্ত্রণালয়
৯১, মতিঝিল বা/এ, ঢাকা-১০০০
www.dpdt.gov.bd

Publication of Filed Patent Application
Publication No: 33 & Date: 21 June 2026

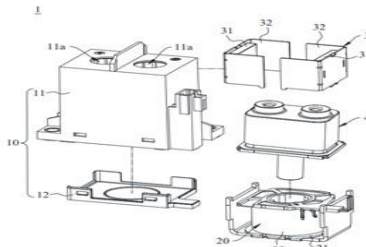
(11) Patent registration No and date , (21) Appl. No. BD-P-2024-276 (22) Filed: 15/09/2024	
(23) Priority Data: China, Number :2023111877872, Date : 14-09-2023.	
(71) Applicant: Xiamen Hongfa Electric Power Controls Co., Ltd. of No. 93 Yinong Road, Haicang District, Xiamen, Fujian 361027, Nationality -China	
(72) Inventors:	
(74) Agent : DOULAH & DOULAH, DOULAH HOUSE (ANNEX), PLOT-153/2, ROAD-2/2, BLOCK- A, SECTION-12, MIRPUR, DHAKA-1216, DHAKA, Bangladesh	
(51) INT. CL. : F16K 31/06	
(54) Invention Title: RELAY	
(57) Abstract A relay includes a pair of static contact leading-out terminals (2000); a movable contact assembly (3100) including a movable contact piece (3110) are configured to contact with or separate from the pair of static contact leading-out terminals (2000) along a first direction (D1); the movable contact assembly (3100) has a first and a second side surfaces (3100b) along a third direction (D3); wherein a moving direction of the movable contact piece (3110), the first direction (D1), and the third direction (D3) are perpendicular with each other; a push rod assembly (3200) including a contact bracket (3220); the contact bracket (3220) has a first side wall (3222a) corresponding to the first side surface (3100a) and a second side wall (3222b) corresponding to the second side surface (3100b) along the third direction (D3); and an anti-rotation structure (300) including a first anti-rotation piece (310) located between the first side wall (3222a) and the first side surface (3100a) and a second anti-rotation piece (320) located between the second side wall (3222b) and the second side surface (3100b).	
 <p>Fig. 1</p>	



গণপ্রজাতন্ত্রী বাংলাদেশ সরকার
পেটেন্ট, শিল্প-নকশা ও ট্রেডমার্কস অধিদপ্তর
শিল্প মন্ত্রণালয়
৯১, মতিঝিল বা/এ, ঢাকা-১০০০
www.dpdt.gov.bd

Publication of Filed Patent Application
Publication No: 33 & Date: 21 June 2026

(11) Patent registration No and date , (21) Appl. No. BD-P-2024-277 (22) Filed: 15/09/2024	
(23) Priority Data: China, Number :2023111897467, Date : 14-09-2023.	
(71) Applicant: Xiamen Hongfa Electric Power Controls Co., Ltd. of No. 93 Yinong Road, Haicang District, Xiamen, Fujian 361027, Nationality -China	
(72) Inventors:	
(74) Agent : DOULAH & DOULAH, DOULAH HOUSE (ANNEX), PLOT-153/2, ROAD-2/2, BLOCK- A, SECTION-12, MIRPUR, DHAKA-1216, DHAKA, Bangladesh	
(51) INT. CL. : F16K 31/06	
(54) Invention Title: RELAY	
(57) Abstract A relay includes a movable contact assembly (3100) including a movable contact piece (3110); a push rod assembly (3200) configured to push the movable contact assembly (3100) to move so that the movable contact piece (3110) contacts with or separates from a static contact leading-out terminal (2000); and an elastic assembly (3230) connected to the push rod assembly (3200) through a first anti-rotation structure (300) and connected to the movable contact assembly (3100) through a second anti-rotation structure (400), the elastic assembly (3230) is configured to provide contact pressure and to limit the movable contact assembly (3100) from rotating relative to the push rod assembly (3200) around an axis of the push rod assembly (3200).	



গণপ্রজাতন্ত্রী বাংলাদেশ সরকার
পেটেন্ট, শিল্প-নকশা ও ট্রেডমার্কস অধিদপ্তর
শিল্প মন্ত্রণালয়
৯১, মতিঝিল বা/এ, ঢাকা-১০০০
www.dpdt.gov.bd

Publication of Filed Patent Application
Publication No: 33 & Date: 21 June 2026

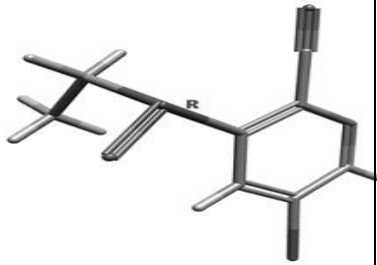
(11) Patent registration No and date , (21) Appl. No. BD-P-2024-278 (22) Filed: 17/09/2024
(23) Priority Data: European Patent Office (EPO), Number :231983396, Date : 19-09-2023.
(71) Applicant: SYNGENTA CROP PROTECTION AG of Rosentalstrasse 67, 4058 Basel, Nationality -Switzerland
(72) Inventors: (1) SMITS, Helmars of Syngenta Crop Protection AG, Schaffhauserstrasse, 4332 Stein, Switzerland Nationality -Latvia, (2) DUMEUNIER, Raphael of Syngenta Crop Protection AG, Schaffhauserstrasse, 4332 Stein, Switzerland Nationality -Belgium, (3) PERROTTA, Daniele of Syngenta Crop Protection AG, Schaffhauserstrasse, 4332 Stein, Switzerland Nationality -Italy
(74) Agent : Advanced IP Law Firm, Suite#9/C (9th Floor), Fahima Tower, 42-43, Purana Paltan, Dhaka-1000, Bangladesh
(51) INT. CL. : C09K 15/08
(54) Invention Title: SYNTHESIS OF SULFOXIMINES CONTAINING A BENZIMIDAZOLE MOIETY
(57) Abstract A process for the preparation of enantiomerically enriched sulfoximines of formula (I) is provided (I) wherein R1, R2, S*, R3, R4, X1 and X2 are as defined in the description.
 <p style="text-align: right;">Figure 1</p>



গণপ্রজাতন্ত্রী বাংলাদেশ সরকার
পেটেন্ট, শিল্প-নকশা ও ট্রেডমার্কস অধিদপ্তর
শিল্প মন্ত্রণালয়
৯১, মতিঝিল বা/এ, ঢাকা-১০০০
www.dpdt.gov.bd

Publication of Filed Patent Application
Publication No: 33 & Date: 21 June 2026

(11) Patent registration No and date , (21) Appl. No. BD-P-2024-279 (22) Filed: 17/09/2024	
(23) Priority Data: United States of America, Number :63589491, Date : 11-10-2023.	
(71) Applicant: Nokia Technologies Oy of Karakaari 7, 02610 Espoo, Nationality -Finland	
(72) Inventors: (1) Samuli Heikki TURTINEN of Salongintie 15, Ii, 91100, Finland Nationality -Finland, (2) Jussi-Pekka KOSKINEN of Kipinäkuja 10, Oulu, 90420, Finland Nationality -Finland, (3) Jarkko Tuomo KOSKELA of Kajuuttapiha 3, Oulu, 90510, Finland Nationality -Finland	
(74) Agent : REMFRY & SON LIMITED, 56, NEW ESKATON ROAD 4TH FLOOR, DHAKA-1000, DHAKA, Bangladesh	
(51) INT. CL. : E05B 85/10	
(54) Invention Title: HANDLING EMERGENCY ACCESS	
(57) Abstract Example embodiments of the present disclosure relate to handling emergency access. A method comprises: at a first apparatus, in accordance with a determination that an access to a cell by the first apparatus is barred, monitoring an indication related to an emergency access in the cell; determining, based on a result of the monitoring, whether the first apparatus is allowed to perform emergency access in the cell.	



গণপ্রজাতন্ত্রী বাংলাদেশ সরকার
পেটেন্ট, শিল্প-নকশা ও ট্রেডমার্কস অধিদপ্তর
শিল্প মন্ত্রণালয়
৯১, মতিঝিল বা/এ, ঢাকা-১০০০
www.dpdt.gov.bd

Publication of Filed Patent Application
Publication No: 33 & Date: 21 June 2026

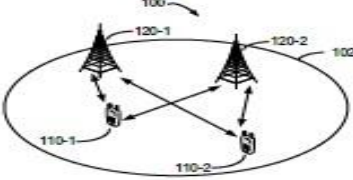
(11) Patent registration No and date , (21) Appl. No. BD-P-2024-280 (22) Filed: 17/09/2024	
(23) Priority Data: China, Number :2023121240, Date : 25-09-2023.	
(71) Applicant: Nokia Technologies Oy of Karakaari 7, 02610 Espoo, Nationality -Finland	
(72) Inventors: (0) Samuli Heikki TURTINEN of Salongintie 15, Ii, 91100, Finland Nationality -Finland, (1) Chunli WU of No.1 Wangjing East Road, Chaoyang, Beijing, 100102, China Nationality -China	
(74) Agent : REMFRY & SON LIMITED, 56, NEW ESKATON ROAD 4TH FLOOR, DHAKA-1000, DHAKA, Bangladesh	
(51) INT. CL. : G07C 1/04	
(54) Invention Title: TIMING ADVANCE GROUP INDICATION	
(57) Abstract Embodiments of the present disclosure relate to devices, methods, apparatuses and computer readable storage media of blind user equipment (UE) specific timing advance group (TAG) indication. The method comprises: determining, at a first apparatus, whether an association between at least one TAG associated with a SpCell of the first apparatus and respective one or more indices in an RAR is obtained from a second apparatus; and determining, based on the determination of the association, an applicability of the RAR for a random access procedure of the first apparatus.	



গণপ্রজাতন্ত্রী বাংলাদেশ সরকার
 পেটেন্ট, শিল্প-নকশা ও ট্রেডমার্কস অধিদপ্তর
 শিল্প মন্ত্রণালয়
 ৯১, মতিঝিল বা/এ, ঢাকা-১০০০
www.dpd.gov.bd

Publication of Filed Patent Application
Publication No: 33 & Date: 21 June 2026

(11) Patent registration No and date , (21) Appl. No. BD-P-2024-281 (22) Filed: 17/09/2024	
(23) Priority Data: United States of America, Number :63539712, Date : 21-09-2023.	
(71) Applicant: Nokia Technologies Oy of Karakaari 7, 02610 Espoo, Nationality -Finland	
(72) Inventors: (1) Tero HENTTONEN of Joupinkuja 4 A 5, Espoo, 02760, Finland Nationality -Finland, (2) Samuli Heikki TURPINEN of Salongintie 15, Ii, 91100, Finland Nationality -Finland, (3) Jussi-Pekka KOSKINEN of Kipinäkuja 10, Oulu, 90420, Finland Nationality -Finland	
(74) Agent : REMFRY & SON LIMITED, 56, NEW ESKATON ROAD 4TH FLOOR, DHAKA-1000, DHAKA, Bangladesh	
(51) INT. CL. : B60F 5/00	
(54) Invention Title: OPTIMIZED UE CAPABILITY	
(57) Abstract An apparatus configured to: receive, from a network node, a user equipment capability enquiry;determine whether ignoring a capability filter in a cell is allowed; generate a capability information message based, at least partially, on a determination of whether ignoring the capability filter in the cell is allowed; andtransmit, to the network node, the capability information message. An apparatus configured to: provide, to a user equipment, an indication of whether the user equipment is allowed to ignore a capability filter in a cell; provide, to the user equipment, a user equipment capability enquiry with respect to, at least, the capability filter; andreceive, from the user equipment in response to the user equipment capability enquiry, a capability information message.	



গণপ্রজাতন্ত্রী বাংলাদেশ সরকার
পেটেন্ট, শিল্প-নকশা ও ট্রেডমার্কস অধিদপ্তর
শিল্প মন্ত্রণালয়
৯১, মতিঝিল বা/এ, ঢাকা-১০০০
www.dpdt.gov.bd

Publication of Filed Patent Application
Publication No: 33 & Date: 21 June 2026

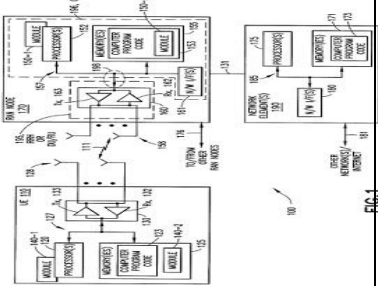
(11) Patent registration No and date , (21) Appl. No. BD-P-2024-282 (22) Filed: 17/09/2024
(23) Priority Data: United States of America, Number :63539720, Date : 21-09-2023.
(71) Applicant: Nokia Technologies Oy of Karakaari 7, 02610 Espoo, Nationality -Finland
(72) Inventors: (1) Tero HENTTONEN of Joupinkuja 4 A 5, Espoo, 02760, Finland Nationality -Finland, (2) Samuli Heikki TURPINEN of Salongintie 15, Ii, 91100, Finland Nationality -Finland, (3) Jussi-Pekka KOSKINEN of Kipinäkuja 10, Oulu, 90420, Finland Nationality -Finland
(74) Agent : REMFRY & SON LIMITED, 56, NEW ESKATON ROAD 4TH FLOOR, DHAKA-1000, DHAKA, Bangladesh
(51) INT. CL. : E04B 9/08
(54) Invention Title: INDICATION OF UE CAPABILITY USAGE.
(57) Abstract An apparatus configured to: determine whether to ignore a capability filter, wherein the capability filter defines a set of frequency bands for reporting a capability information message; and transmit, to a network node in response to the determining, an indication of whether the apparatus has determined to ignore the capability filter. An apparatus configured to: transmit, to a user equipment, a user equipment capability enquiry, wherein the user equipment capability enquiry comprises, at least, a capability filter defining a set of frequency bands for reporting a capability information message; receive, from the user equipment, an indication of whether the user equipment has determined to ignore the capability filter; and determine, whether to request at least one additional capability from the user equipment based, at least partially, on the indication.



গণপ্রজাতন্ত্রী বাংলাদেশ সরকার
পেটেন্ট, শিল্প-নকশা ও ট্রেডমার্কস অধিদপ্তর
শিল্প মন্ত্রণালয়
৯১, মতিঝিল বা/এ, ঢাকা-১০০০
www.dpdt.gov.bd

Publication of Filed Patent Application
Publication No: 33 & Date: 21 June 2026

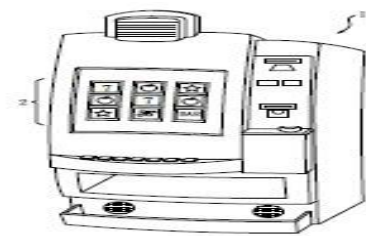
(11) Patent registration No and date , (21) Appl. No. BD-P-2024-285 (22) Filed: 19/09/2024	
(23) Priority Data: N/A	
(71) Applicant: JUMBO TECHNOLOGY CO., LTD. of 6F.-1, 6F.-2, 6F.-3, 6F.-5, NO.210, GONGYECYU 38TH RD., SHITUN DIST., TAICHUNG CITY 407, Nationality -China	
(72) Inventors: (1) HSU, Shun Tsung of 6F.-1, 6F.-2, 6F.-3, 6F.-5, NO.210, GONGYECYU 38TH RD., SHITUN DIST., TAICHUNG CITY 407, China Nationality -China, (2) WANG, Chang Yi of 6F.-1, 6F.-2, 6F.-3, 6F.-5, NO.210, GONGYECYU 38TH RD., SHITUN DIST., TAICHUNG CITY 407, China Nationality -China	
(74) Agent : Rana & Associates, Nipobon Asgar Garden, 462, Green Way, Flat No. A/2 (2nd Floor), Moghbazar, Dhaka-1217, Bangladesh	
(51) INT. CL. : G07F 17/34	
(54) Invention Title: GAME SYSTEM CAPABLE OF DETERMINING USE TIME	
(57) Abstract The present invention relates to a game system for storing a special symbol and freely deciding when to use the special symbol. Any one of a plurality of special symbols generated is stored in a temporary storing unit, and the plurality of special symbols each have a game effect. A process unit determines whether a player uses at least one special symbol stored in the temporary storing unit to perform a special symbol step or a normal game step, and in the special symbol step, the process unit generates a corresponding game effect, and deletes the used special symbol. According to the present invention, the special symbols having different game effects can be collected, and the player can freely select use time, so that the player can wait for optimal use time, the effect of continuously using the game system is achieved, and the turnover of the game system can be effectively increased.	



গণপ্রজাতন্ত্রী বাংলাদেশ সরকার
পেটেন্ট, শিল্প-নকশা ও ট্রেডমার্কস অধিদপ্তর
শিল্প মন্ত্রণালয়
৯১, মতিঝিল বা/এ, ঢাকা-১০০০
www.dpdt.gov.bd

Publication of Filed Patent Application
Publication No: 33 & Date: 21 June 2026

(11) Patent registration No and date , (21) Appl. No. BD-P-2024-286 (22) Filed: 19/09/2024	
(23) Priority Data: United States of America, Number :63539538, Date : 20-09-2023.	
(71) Applicant: Kerry Group Services International Limited of Prince's Street, Tralee Co. Kerry, V92 EH11, Nationality -Ireland	
(72) Inventors: (1) OLIVARES MARTÍN, Mónica of Jamileros 4, Cájar, Granada 18199, Spain Nationality -Spain, (2) BAÑUELOS HORTIGÜELA, Oscar of Calle Maria Zambrano N° 20, Cullar Vega, Granada 18195, Spain Nationality - Spain, (3) BLANCO ROJO, Ruth of c/o Cuesta de Prausteros 2, Colmenarejo 28270, Madrid, Spain Nationality -Spain, (4) HURTADO SUAZO, Jose Antonio of Plaza Sor Cristina de la Cruz Arteaga 5, 1 Izq, Granada 18001, Spain Nationality -Spain	
(74) Agent : Rana & Associates, Nipobon Asgar Garden, 462, Green Way, Flat No. A/2 (2nd Floor), Moghbazar, Dhaka-1217, Bangladesh	
(51) INT. CL. : A61P 9/00	
(54) Invention Title: COMPOSITIONS TO IMPROVE IMMUNE SYSTEM AND GUT FUNCTION AND TO TREAT PERSISTENT DUCTUS ARTERIOSUS IN INFANTS	
(57) Abstract The invention relates to compositions for treating or preventing persistent ductus arteriosus in infants, in particular neonates who were born preterm. The invention also relates to compositions for treating or preventing sepsis, improving the immune system and gut function. Figure 3A is to accompany the abstract.	<p>Figure 1</p> <p>Birth Weekly follow-up 32 weeks 34 weeks 37 weeks</p> <p>Group LD</p> <p>Group HD</p>



গণপ্রজাতন্ত্রী বাংলাদেশ সরকার
পেটেন্ট, শিল্প-নকশা ও ট্রেডমার্কস অধিদপ্তর
শিল্প মন্ত্রণালয়
৯১, মতিঝিল বা/এ, ঢাকা-১০০০
www.dpdt.gov.bd

Publication of Filed Patent Application
Publication No: 33 & Date: 21 June 2026

(11) Patent registration No and date , (21) Appl. No. BD-P-2024-287 (22) Filed: 24/09/2024
(23) Priority Data: India, Number :202421037585, Date : 13-05-2024.
(71) Applicant: GODREJ CONSUMER PRODUCTS LIMITED of 4th Floor Godrej One, Pirojshanagar, Eastern Express Highway, Vikhroli East, Mumbai – 400079, Maharashtra, Nationality -India
(72) Inventors: (1) RAGHAVACHARI, Rajan of Godrej Consumer Products Ltd., 4th Floor, Godrej One, Pirojshanagar, Eastern Express Highway, Vikhroli (East), Mumbai 400079, Maharashtra, India Nationality -India, (2) YADLAPALLI, Venkateswara of Godrej Consumer Products Ltd., 4th Floor, Godrej One, Pirojshanagar, Eastern Express Highway, Vikhroli (East), Mumbai 400079, Maharashtra, India Nationality -India, (3) NAYAK, Meghana of Godrej Consumer Products Ltd., 4th Floor, Godrej One, Pirojshanagar, Eastern Express Highway, Vikhroli (East), Mumbai 400079, Maharashtra, India Nationality -India, (4) KUMAR, Krishnaraj of Godrej Consumer Products Ltd., 4th Floor, Godrej One, Pirojshanagar, Eastern Express Highway, Vikhroli (East), Mumbai 400079, Maharashtra, India Nationality -India, (5) RAWAT, Rupinder Kaur of Godrej Consumer Products Ltd., 4th Floor, Godrej One, Pirojshanagar, Eastern Express Highway, Vikhroli (East), Mumbai 400079, Maharashtra, India Nationality -India, (6) OVHAL, Vinod of Godrej Consumer Products Ltd., 4th Floor, Godrej One, Pirojshanagar, Eastern Express Highway, Vikhroli (East), Mumbai 400079, Maharashtra, India Nationality -India, (7) PETER KURUTHIKULAM, Abraham of Godrej Consumer Products Ltd., 4th Floor, Godrej One, Pirojshanagar, Eastern Express Highway, Vikhroli (East), Mumbai 400079, Maharashtra, India Nationality -India
(74) Agent : Advanced IP Law Firm, Suite#9/C (9th Floor), Fahima Tower, 42-43, Purana Paltan, Dhaka-1000, Bangladesh
(51) INT. CL. : A45D 19/18
(54) Invention Title: SELF OXIDATIVE SINGLE COMPOSITION HAIR COLOUR
(57) Abstract Disclosed herein is a single composition self oxidative hair colour product containing optimal concentration of self-oxidative molecule preferably Gallic acid which leads to the desired shade (intensity and coverage) within an intended duration of treatment. Gallic acid auto oxidises in the presence of air and alkaline pH further enabling oxidation of oxidative dyes (precursors and couplers) present in the colorant leading to shade delivery on the hair. The composition of invention is preferably an antioxidant-free formulation.
 Fig 1



গণপ্রজাতন্ত্রী বাংলাদেশ সরকার
পেটেন্ট, শিল্প-নকশা ও ট্রেডমার্কস অধিদপ্তর
শিল্প মন্ত্রণালয়
৯১, মতিঝিল বা/এ, ঢাকা-১০০০
www.dpdt.gov.bd

Publication of Filed Patent Application
Publication No: 33 & Date: 21 June 2026

(11) Patent registration No and date , (21) Appl. No. BD-P-2024-288 (22) Filed: 24/09/2024	
(23) Priority Data: United States of America, Number :63540470, Date : 26-09-2023.	
(71) Applicant: Nokia Technologies Oy of Karakaari 7, 02610 Espoo, Nationality -Finland	
(72) Inventors: (0) Timo KOSKELA of Suojuoksuntie 2 B 7, Oulu, 90670, Finland Nationality -Finland, (1) Riikka Karoliina DIMNIK of Lohansuontie 7 L, Kirkkonummi,02880, Finland Nationality -Finland, (2) Jani-Pekka KAINULAINEN of 3 Peacock Close, Cottenham, CB24 8BA, United Kingdom Nationality -Finland, (3) Lars DALSGAARD of Torpantie 56, Oulu, 90230, Finland Nationality -Denmark, (4) Sanjay GOYAL of 304 Dalton Ct, Denville, New Jersey, 07834, United States of America Nationality -India, (5) Samuli Heikki TURTINEN of Salongintie 15, Ii, 91100, Finland Nationality -Finland	
(74) Agent : REMFRY & SON LIMITED, 56, NEW ESKATON ROAD 4TH FLOOR, DHAKA-1000, DHAKA, Bangladesh	
(51) INT. CL. : H04W 36/00	
(54) Invention Title: METHOD AND APPARATUS FOR TCI STATE DEACTIVATION AND ACTIVATION	
(57) Abstract A user equipment (UE) may receive, from a network entity, a configuration of one or more candidate cells for switching to from a serving cell. The UE may receive, from the network entity, an indication to deactivate all transmission configuration indicator (TCI) states associated with one or more indicated cells. The UE may deactivate the all TCI states associated with the one or more indicated cells based at least in part on receiving the indication to deactivate the all TCI states. One or more of the one or more candidate cells or the serving cell may include the one or more indicated cells.	<pre>sequenceDiagram participant UE as 105 UE participant gNB as 115-a gNB participant gNB as 115-b gNB Note over UE: UE in RRC_CONNECTED CM-CONNECTED gNB->>UE: 1. RRC Reconfiguration (including a list of TCI states of Cell B) UE->>gNB: 2. RRC Reconfiguration Complete gNB->>UE: 3. Early TCI state activation MAC CE (indicating TCI state(s) of Cell B) Note over UE: 4. UE deactivates the TCI state(s) of Cell B Note over UE: 5. TCI state (e.g. in cell switch command indicating Cell B as target cell)</pre>



গণপ্রজাতন্ত্রী বাংলাদেশ সরকার
 পেটেন্ট, শিল্প-নকশা ও ট্রেডমার্কস অধিদপ্তর
 শিল্প মন্ত্রণালয়
 ৯১, মতিঝিল বা/এ, ঢাকা-১০০০
www.dpdt.gov.bd

Publication of Filed Patent Application
Publication No: 33 & Date: 21 June 2026

(11) Patent registration No and date ,	
(21) Appl. No. BD-P-2024-289	
(22) Filed: 24/09/2024	
(23) Priority Data:	
United Kingdom, Number :23148281, Date : 27-09-2023.	
(71) Applicant:	Nokia Technologies Oy of Karakaari 7, 02610 Espoo, Nationality -Finland
(72) Inventors:	(1) Lars DALSGAARD of Torpantie 56, Oulu, 90230, Finland Nationality -Denmark, (2) Riikka Karoliina DIMNIK of Lohansuontie 7 L, Kirkkonummi,02880, Finland Nationality -Finland, (3) Jani-Pekka KAINULAINEN of 3 Peacock Close, Cottenham, CB24 8BA, United Kingdom Nationality -Finland
(74) Agent :	REMFY & SON LIMITED, 56, NEW ESKATON ROAD 4TH FLOOR, DHAKA-1000, DHAKA, Bangladesh
(51) INT. CL. :	G06G 7/06
(54) Invention Title:	METHOD, APPARATUS AND COMPUTER PROGRAM
(57) Abstract	<p>There is provided an apparatus comprising: means for receiving (600), on a source cell, a radio resource control configuration for at least one candidate cell including first configuration information and second configuration information; means for decoding (602) the first configuration information; means for performing (604) the at least one measurement based on the first configuration information; means for transmitting (606), on the source cell, a measurement report comprising at least one result of the at least one measurement; means for receiving (608), on the source cell, a message triggering the apparatus to decode the second configuration information; means for decoding (610) the second configuration information; means for receiving, on the source cell, a command to switch the apparatus to a target cell selected amongst the at least one candidate cell; and means for switching (612) to the target cell based on the second configuration information.</p>

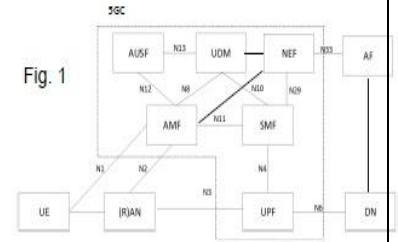



গণপ্রজাতন্ত্রী বাংলাদেশ সরকার
পেটেন্ট, শিল্প-নকশা ও ট্রেডমার্কস অধিদপ্তর
শিল্প মন্ত্রণালয়
৯১, মতিঝিল বা/এ, ঢাকা-১০০০
www.dpdt.gov.bd

Publication of Filed Patent Application
Publication No: 33 & Date: 21 June 2026

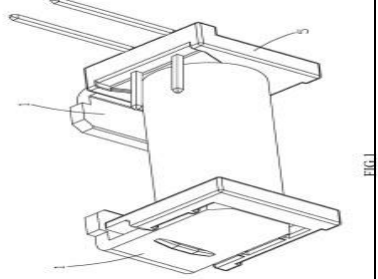
(11) Patent registration No and date , (21) Appl. No. BD-P-2024-290 (22) Filed: 25/09/2024
(23) Priority Data: China, Number :2023112512048, Date : 26-09-2023.
(71) Applicant: Xiamen Hongfa Electric Power Controls Co., Ltd. of No. 93 Yinong Road, Haicang District, Xiamen, Fujian 361027, Nationality -China
(72) Inventors:
(74) Agent : DOULAH & DOULAH, DOULAH HOUSE (ANNEX), PLOT-153/2, ROAD-2/2, BLOCK- A, SECTION-12, MIRPUR, DHAKA-1216, DHAKA, Bangladesh
(51) INT. CL. : F16D 65/12
(54) Invention Title: CONNECTION STRUCTURE FOR YOKE AND IRON CORE, COIL ASSEMBLY AND RELAY
(57) Abstract The present disclosure provides a connection structure for a yoke and an iron core, a coil assembly and a relay. The connection structure includes the yoke and the iron core. The yoke has a yoke assembling surface, and the iron core has an iron core assembling end corresponding to the yoke assembling surface. One of the yoke assembling surface and the iron core assembling end is provided with a protrusion, and the other thereof is provided with a concave hole of a blind hole structure. The yoke and the iron core are connected together by an interference fit through male-female insertion between the protrusion and the concave hole. According to the present disclosure, the yoke is connected with the end of the iron core by the interference fit through male-female insertion between the protrusion and the concave hole which are fitted with each other, and a connection position is on an inner side of the yoke assembling surface1, which can improve the problem of magnetic leakage at the riveting position caused by riveting between the yoke and the iron core, and ensure that the magnetic field circulates inside the magnetic circuit as much as possible.



গণপ্রজাতন্ত্রী বাংলাদেশ সরকার
পেটেন্ট, শিল্প-নকশা ও ট্রেডমার্কস অধিদপ্তর
শিল্প মন্ত্রণালয়
৯১, মতিঝিল বা/এ, ঢাকা-১০০০
www.dpdt.gov.bd

Publication of Filed Patent Application
Publication No: 33 & Date: 21 June 2026

(11) Patent registration No and date , (21) Appl. No. BD-P-2024-291 (22) Filed: 25/09/2024	
(23) Priority Data: United States of America, Number :63602487, Date : 24-11-2023.	
(71) Applicant: Nokia Technologies Oy of Karakaari 7, 02610 Espoo, Nationality -Finland	
(72) Inventors: (0) Sanjay GOYAL of 304 Dalton Ct, Denville, New Jersey, 07834, United States of America Nationality -India, (1) Timo KOSKELA of Suojuoksuntie 2 B 7, Oulu, 90670, Finland Nationality -Finland	
(74) Agent : REMFRY & SON LIMITED, 56, NEW ESKATON ROAD 4TH FLOOR, DHAKA-1000, DHAKA, Bangladesh	
(51) INT. CL. : H04W 52/28	
(54) Invention Title: CHANNEL STATE INFORMATION REPORTING PRIORITY FOR LOWER-LAYER TRIGGERED MOBILITY	
(57) Abstract A method is provided that includes determining that at least two channel state information (CSI) reports are to be reported. The method includes calculating priority values associated with the at least two CSI reports, at least one of the priority values calculated based on a determination that at least one of the at least two CSI reports is a lower-layered triggered mobility (LTM) CSI report. The method includes determining that a time occupancy of physical channels scheduled to carry the at least two CSI reports at least partially overlap on a carrier, the at least two CSI reports thereby said to collide. And the method includes sending one or more of the at least two CSI reports that are said to collide based on the priority values.	<p>FIG. 1</p>



গণপ্রজাতন্ত্রী বাংলাদেশ সরকার
 পেটেন্ট, শিল্প-নকশা ও ট্রেডমার্কস অধিদপ্তর
 শিল্প মন্ত্রণালয়
 ৯১, মতিঝিল বা/এ, ঢাকা-১০০০
www.dpdt.gov.bd

**Publication of Filed Patent Application
 Publication No: 33 & Date: 21 June 2026**

(11) Patent registration No and date ,	
(21) Appl. No. BD-P-2024-292	
(22) Filed: 25/09/2024	
(23) Priority Data:	
China, Number :2023112771254, Date : 28-09-2023.	
(71) Applicant: HUNAN WULING POWER TECHNOLOGY CO., LTD. of No. 188, Wuling Road, Tianxin District, Changsha City, Hunan Province, 410004, Nationality -China, WULING POWER CORPORATION LTD. of No. 188, Wuling Road, Tianxin District, Changsha City, Hunan Province, 410004, Nationality -China	
(72) Inventors: (2) Chengcheng LI of No. 188, Wuling Road, Tianxin District, Changsha City, Hunan Province, 410004, China Nationality -China, (3) Yongsheng HU of No. 188, Wuling Road, Tianxin District, Changsha City, Hunan Province, 410004, China Nationality -China, (4) Yuan WAN of No. 188, Wuling Road, Tianxin District, Changsha City, Hunan Province, 410004, China Nationality -China, (5) Pingheng PAN of No. 188, Wuling Road, Tianxin District, Changsha City, Hunan Province, 410004, China Nationality -China, (6) Wei TANG of No. 188, Wuling Road, Tianxin District, Changsha City, Hunan Province, 410004, China Nationality -China, (7) Bian HU of No. 188, Wuling Road, Tianxin District, Changsha City, Hunan Province, 410004, China Nationality -China, (8) Miao CHEN of No. 188, Wuling Road, Tianxin District, Changsha City, Hunan Province, 410004, China Nationality -China, (9) Wang CAO of No. 188, Wuling Road, Tianxin District, Changsha City, Hunan Province, 410004, China Nationality -China, (10) Haotian WU of No. 188, Wuling Road, Tianxin District, Changsha City, Hunan Province, 410004, China Nationality -China, (11) Xueshun LIAO of No. 188, Wuling Road, Tianxin District, Changsha City, Hunan Province, 410004, China Nationality -China	
(74) Agent : SUPREMEiP law Firm, 121 Motijheel C/A (1st Floor), Dhaka-1000, Bangladesh	
(51) INT. CL. : F23D 14/02	
(54) Invention Title: APPARATUS AND METHOD FOR DETECTING MIXED GAS, ELECTRONIC DEVICE AND STORAGE MEDIUM	
(57) Abstract An apparatus and a method for detecting a mixed gas, an electronic device, and a storage medium are provided in the disclosure. The method for detecting the mixed gas includes: respectively calibrating the mixed gas to obtain calibration curves; and performing secondary harmonic correction at a characteristic wavelength of ethane in detection of the mixed gas according to linear correction principle of time-domain waveforms. The disclosure has beneficial effects that stability and accuracy of detection of the mixed gas which is susceptible to noise and has overlapping wavelengths are improved.	<p>FIG. 1</p> <p>FIG. 2</p>



গণপ্রজাতন্ত্রী বাংলাদেশ সরকার
পেটেন্ট, শিল্প-নকশা ও ট্রেডমার্কস অধিদপ্তর
শিল্প মন্ত্রণালয়
৯১, মতিঝিল বা/এ, ঢাকা-১০০০
www.dpdt.gov.bd

Publication of Filed Patent Application
Publication No: 33 & Date: 21 June 2026

(11) Patent registration No and date , (21) Appl. No. BD-P-2024-294 (22) Filed: 26/09/2024
(23) Priority Data: United Kingdom, Number :23150782, Date : 02-10-2023.
(71) Applicant: Nokia Technologies Oy of Karakaari 7, 02610 Espoo, Nationality -Finland
(72) Inventors: (1) Jose Angel LEON CALVO of Euckenstr. 8, Munich, 81369, Germany Nationality -Spain, (2) Sung Hwan WON of 1250 Mourning Dove Dr, Flower Mound, Texas, 75028, United States of America Nationality -Republic of Korea
(74) Agent : REMFRY & SON LIMITED, 56, NEW ESKATON ROAD 4TH FLOOR, DHAKA-1000, DHAKA, Bangladesh
(51) INT. CL. : H04W 48/18
(54) Invention Title: DISABLING N1 MODE UPON RECEIVING A 5GMM CAUSE VALUE MESSAGE
(57) Abstract A method includes transmitting, by a user equipment (UE), a first message to a network node, the first message including a request for access to a first network according to a non-access stratum (NAS) protocol. The UE receives a second message from the network node, the second message including an indication of no network slice being available to service access to the first network requested by the UE. The UE disables a capability to access networks using the NAS protocol based upon the receiving the second message, stores an identity of the first network, and after storing, exploits the stored identity of the first network, by the UE, during a network selection process.
<p>FIG. 1</p>



গণপ্রজাতন্ত্রী বাংলাদেশ সরকার
পেটেন্ট, শিল্প-নকশা ও ট্রেডমার্কস অধিদপ্তর
শিল্প মন্ত্রণালয়
৯১, মতিঝিল বা/এ, ঢাকা-১০০০
www.dpdt.gov.bd

Publication of Filed Patent Application
Publication No: 33 & Date: 21 June 2026

(11) Patent registration No and date , (21) Appl. No. BD-P-2024-295 (22) Filed: 26/09/2024	
(23) Priority Data: United Kingdom, Number :23150790, Date : 02-10-2023.	
(71) Applicant: Nokia Technologies Oy of Karakaari 7, 02610 Espoo, Nationality -Finland	
(72) Inventors: (1) Jose Angel LEON CALVO of Euckenstr. 8, Munich, 81369, Germany Nationality -Spain, (2) Sung Hwan WON of 1250 Mourning Dove Dr, Flower Mound, Texas, 75028, United States of America Nationality -Republic of Korea	
(74) Agent : REMFRY & SON LIMITED, 56, NEW ESKATON ROAD 4TH FLOOR, DHAKA-1000, DHAKA, Bangladesh	
(51) INT. CL. : G10K 11/18	
(54) Invention Title: DISABLING N1 MODE UPON RECEIVING A 5GMM CAUSE VALUE MESSAGE	
(57) Abstract A method includes transmitting, by a user equipment (UE), a registration request message to a network node according to a non-access stratum (NAS) protocol, the registration request message including a request for one or more single-network slice selection assistance informations (S-NSSAIs) in a first network. The UE receives a registration reject message from the network node, the registration reject message including a 5G system mobility management (5GMM) cause value #62 “no network slices available” indication. The UE disables N1 mode capability for the first network based upon the receiving the registration reject message, stores an identity of the first network, and, after storing, exploits the stored identity of the first network, by the UE, during a network selection process.	<pre>graph LR UE[150] <--> NN1((100)) subgraph NN1 S[110 Server] NE[130 Network Equipment] end NN1 <--> NN2[120 Network Node]</pre>

FIG. 1



গণপ্রজাতন্ত্রী বাংলাদেশ সরকার
 পেটেন্ট, শিল্প-নকশা ও ট্রেডমার্কস অধিদপ্তর
 শিল্প মন্ত্রণালয়
 ৯১, মতিঝিল বা/এ, ঢাকা-১০০০
www.dpdt.gov.bd

Publication of Filed Patent Application
Publication No: 33 & Date: 21 June 2026

(11) Patent registration No and date ,	
(21) Appl. No. BD-P-2024-296	
(22) Filed: 29/09/2024	
(23) Priority Data:	
China, Number :2023112771254, Date : 28-09-2023.	
(71) Applicant: HUNAN WULING POWER TECHNOLOGY CO., LTD. of No. 188, Wuling Road, Tianxin District, Changsha City, Hunan Province, 410004, Nationality -China, WULING POWER CORPORATION LTD. of No. 188, Wuling Road, Tianxin District, Changsha City, Hunan Province, 410004, Nationality -China	
(72) Inventors: (2) Chengcheng LI of No. 188, Wuling Road, Tianxin District, Changsha City, Hunan Province, 410004, China Nationality -China, (3) Yongsheng HU of No. 188, Wuling Road, Tianxin District, Changsha City, Hunan Province, 410004, China Nationality -China, (4) Yuan WAN of No. 188, Wuling Road, Tianxin District, Changsha City, Hunan Province, 410004, China Nationality -China, (5) Pingheng PAN of No. 188, Wuling Road, Tianxin District, Changsha City, Hunan Province, 410004, China Nationality -China, (6) Wei TANG of No. 188, Wuling Road, Tianxin District, Changsha City, Hunan Province, 410004, China Nationality -China, (7) Bian HU of No. 188, Wuling Road, Tianxin District, Changsha City, Hunan Province, 410004, China Nationality -China, (8) Miao CHEN of No. 188, Wuling Road, Tianxin District, Changsha City, Hunan Province, 410004, China Nationality -China, (9) Wang CAO of No. 188, Wuling Road, Tianxin District, Changsha City, Hunan Province, 410004, China Nationality -China, (10) Haotian WU of No. 188, Wuling Road, Tianxin District, Changsha City, Hunan Province, 410004, China Nationality -China, (11) Xueshun LIAO of No. 188, Wuling Road, Tianxin District, Changsha City, Hunan Province, 410004, China Nationality -China	
(74) Agent : Rasheduzzaman Khokon, Advocate, Flat: G, Plot:638, Road:09, Avn: 03, Mirpur DOHS, Dhaka-1216, Bangladesh	
(51) INT. CL. : F23D 14/02	
(54) Invention Title: APPARATUS AND METHOD FOR DETECTING MIXED GAS, ELECTRONIC DEVICE AND STORAGE MEDIUM	
(57) Abstract	
<p>An apparatus and a method for detecting a mixed gas, an electronic device, and a storage medium are provided in the disclosure. The method for detecting the mixed gas includes: respectively calibrating the mixed gas to obtain calibration curves; and performing secondary harmonic correction at a characteristic wavelength of ethane in detection of the mixed gas according to linear correction principle of time-domain waveforms. The disclosure has beneficial effects that stability and accuracy of detection of the mixed gas which is susceptible to noise and has overlapping wavelengths are improved.</p>	
	<p>FIG. 1</p> <p>FIG. 2</p>



গণপ্রজাতন্ত্রী বাংলাদেশ সরকার
পেটেন্ট, শিল্প-নকশা ও ট্রেডমার্কস অধিদপ্তর
শিল্প মন্ত্রণালয়
৯১, মতিঝিল বা/এ, ঢাকা-১০০০
www.dpdt.gov.bd

Publication of Filed Patent Application
Publication No: 33 & Date: 21 June 2026

(11) Patent registration No and date , (21) Appl. No. BD-P-2024-297 (22) Filed: 30/09/2024	
(23) Priority Data: China, Number :2023130310, Date : 07-11-2023.	
(71) Applicant: Nokia Technologies Oy of Karakaari 7, 02610 Espoo, Nationality -Finland	
(72) Inventors: (0) Mads LAURIDSEN of Nørgårdsvej 4B, Gistrup, 9260, Denmark Nationality -Denmark, (1) Ping YUAN of Room 1805, Building 24, ANHUAXILI DISTRICT 1, Chaoyang, Beijing, 100011, China Nationality -China, (2) Jing Yuan SUN of 1601, Building No 4, Block 6 Hepingli, Dongcheng District, Beijing, China Nationality -China, (3) Srinivasan SELVAGANAPATHY of Manyata Embassy Business Park, Bangalore, 560045, India Nationality -India	
(74) Agent : REMFRY & SON LIMITED, 56, NEW ESKATON ROAD 4TH FLOOR, DHAKA-1000, DHAKA, Bangladesh	
(51) INT. CL. : E21B 19/15	
(54) Invention Title: HANDLING POSITIONING MEASUREMENT	
(57) Abstract Example embodiments of the present disclosure relate to a solution for handling positioning measurement. In this solution, a first apparatus may determine a relationship between a completion time of a positioning measurement and an availability time of a serving cell of the first apparatus, or a first time length of a duration for performing the positioning measurement and a second time length of a validity duration of an uplink synchronization parameter in the serving cell. Then based on the determined relationship, the mobility activities may be processed properly.	<p>FIG. 1</p> <p>FIG. 2</p>



গণপ্রজাতন্ত্রী বাংলাদেশ সরকার
পেটেন্ট, শিল্প-নকশা ও ট্রেডমার্কস অধিদপ্তর
শিল্প মন্ত্রণালয়
৯১, মতিঝিল বা/এ, ঢাকা-১০০০
www.dpdt.gov.bd

Publication of Filed Patent Application
Publication No: 33 & Date: 21 June 2026

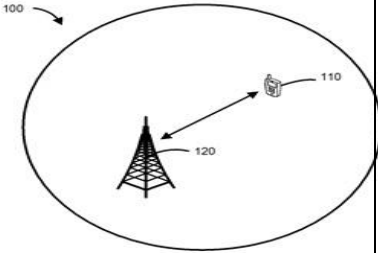
(11) Patent registration No and date , (21) Appl. No. BD-P-2024-298 (22) Filed: 02/10/2024	
(23) Priority Data: China, Number :2023129665, Date : 03-11-2023.	
(71) Applicant: Nokia Technologies Oy of Karakaari 7, 02610 Espoo, Nationality -Finland	
(72) Inventors: (0) Chunli WU of No.1 Wangjing East Road, Chaoyang, Beijing, 100102, China Nationality -China, (1) Benoist Pierre SEBIRE of 6-10-1 Roppongi, Minato-ku, Tokyo, 106-6141, Japan Nationality -France	
(74) Agent : REMFRY & SON LIMITED, 56, NEW ESKATON ROAD 4TH FLOOR, DHAKA-1000, DHAKA, Bangladesh	
(51) INT. CL. : H04W 80/02	
(54) Invention Title: DELAY STATUS REPORT	
(57) Abstract Embodiments of the present disclosure relate to a delay status report (DSR). In an aspect, a terminal device determines a criterion for one or more data units. The one or more data units are buffered and not submitted to a lower layer in a packet data convergence protocol (PDCP). Moreover, the terminal device triggers, based on said criterion, a DSR comprising a data volume of the one or more data units and a remaining time associated with the one or more data units. In this way, it is possible to improve the DSR reporting with enhanced efficiency.	 <p>FIG. 1A</p>



গণপ্রজাতন্ত্রী বাংলাদেশ সরকার
পেটেন্ট, শিল্প-নকশা ও ট্রেডমার্কস অধিদপ্তর
শিল্প মন্ত্রণালয়
৯১, মতিঝিল বা/এ, ঢাকা-১০০০
www.dpdt.gov.bd

Publication of Filed Patent Application
Publication No: 33 & Date: 21 June 2026

(11) Patent registration No and date ,	
(21) Appl. No. BD-P-2024-299	
(22) Filed: 02/10/2024	
(23) Priority Data:	
United States of America, Number :63598291, Date : 13-11-2023.	
(71) Applicant: Nokia Technologies Oy of Karakaari 7, 02610 Espoo, Nationality -Finland	
(72) Inventors: (1) Riikka Karoliina DIMNIK of Lohansuontie 7 L, Kirkkonummi, 02880, Finland Nationality - Finland, (2) Rafael CAUDURO DIAS DE PAIVA of Suojuoksuntie 2 B 7, Oulu, 90670, Denmark Nationality -Brazil	
(74) Agent : REMFRY & SON LIMITED, 56, NEW ESKATON ROAD 4TH FLOOR, DHAKA-1000, DHAKA, Bangladesh	
(51) INT. CL. : H04W 56/00	
(54) Invention Title: Methods For Dual TCI State Switch	
(57) Abstract A method includes: receiving one or more medium-access-control control-elements for one or more transmission configuration indicator state activations, wherein synchronization signal blocks of associated transmission configuration indicator states are overlapping or adjacent, and wherein the transmission configuration indicator states are activated with the one or more medium-access-control control-elements; and determining in which order the individual transmission configuration indicators states are activated.	



গণপ্রজাতন্ত্রী বাংলাদেশ সরকার
 পেটেন্ট, শিল্প-নকশা ও ট্রেডমার্কস অধিদপ্তর
 শিল্প মন্ত্রণালয়
 ৯১, মতিঝিল বা/এ, ঢাকা-১০০০
www.dpdt.gov.bd

Publication of Filed Patent Application
Publication No: 33 & Date: 21 June 2026

(11) Patent registration No and date ,	
(21) Appl. No. BD-P-2024-300	
(22) Filed: 03/10/2024	
(23) Priority Data: China, Number :2024077250, Date : 15-02-2024.	
(71) Applicant: Nokia Technologies Oy of Karakaari 7, 02610 Espoo, Nationality -Finland	
(72) Inventors: (1) Ping YUAN of Room 1805, Building 24, ANHUAXILI DISTRICT1, Chaoyang, Beijing, 100011, China Nationality -China, (2) Jeroen WIGARD of Septembervej 1A, Klarup, 9270, Denmark Nationality -Denmark, (3) Enric JUAN of Áparken 10, 3 4, Aalborg, 9000, Denmark Nationality -Spain	
(74) Agent : REMFRY & SON LIMITED, 56, NEW ESKATON ROAD 4TH FLOOR, DHAKA-1000, DHAKA, Bangladesh	
(51) INT. CL. : G01S 19/28	
(54) Invention Title: SATELLITE SWITCHWITH RESYNCHRONIZATION	
(57) Abstract Embodiments of the present disclosure relate to satellite switch with resynchronization. In an aspect, a terminal device receives, from a network device, an indication for determining time for at least one operation associated with switching from a first satellite to a second satellite. The at least one operation comprises at least one of (i) initiating a resynchronization procedure to the network device via the second satellite or (ii) performing an uplink transmission via the second satellite. The terminal device performs the at least one operation based on the received indication. The embodiments of the present disclosure can avoid scheduling request (SR) bursts at the t-Service and NW overloading due to scheduling a large number of PUSCH transmissions. Therefore, UEs may suffer less risk of long interruptions, and the NW may schedule first UL transmissions of UEs through the target satellite in a distributed manner.	



গণপ্রজাতন্ত্রী বাংলাদেশ সরকার
পেটেন্ট, শিল্প-নকশা ও ট্রেডমার্কস অধিদপ্তর
শিল্প মন্ত্রণালয়
৯১, মতিঝিল বা/এ, ঢাকা-১০০০
www.dpdt.gov.bd

Publication of Filed Patent Application
Publication No: 33 & Date: 21 June 2026

(11) Patent registration No and date , (21) Appl. No. BD-P-2024-301 (22) Filed: 03/10/2024	
(23) Priority Data: Italy, Number :2023000020580, Date : 04-10-2023.	
(71) Applicant: NXTCHEM TECH S.p.A. of Via di Vannina n. 88/94 00156 Roma, Nationality -Italy	
(72) Inventors: (1) ORSETTI, Andrea of c/o Via di Vannina n. 88/94 00156 Roma, Italy Nationality -Italy, (2) FELICI, Paolo of c/o Via di Vannina n. 88/94 00156 Roma, Italy Nationality -Italy, (3) FERRARI, Fabio Enrico Gianfranco of c/o Via di Vannina n. 88/94 00156 Roma, Italy Nationality -Italy	
(74) Agent : REMFRY & SON LIMITED, 56, NEW ESKATON ROAD 4TH FLOOR, DHAKA-1000, DHAKA, Bangladesh	
(51) INT. CL. : B01D 1/28	
(54) Invention Title: METHOD AND SYSTEM FOR CARBON DIOXIDE CAPTURE	
(57) Abstract Disclosed is a method and system to recover heat from hot flue gas and use said heat to regenerate a used CO ₂ capturing fluid. The system comprises, in downstream order, a quenching section, an absorption section, a regeneration section, and a reboiling section. The invention presents the addition of a heat pump configured to recover heat from the quenching section and provide heat to the reboiling section.	<p>FIG 1</p> <p>FIG 2</p> <p>FIG 3</p>



গণপ্রজাতন্ত্রী বাংলাদেশ সরকার
পেটেন্ট, শিল্প-নকশা ও ট্রেডমার্কস অধিদপ্তর
শিল্প মন্ত্রণালয়
৯১, মতিঝিল বা/এ, ঢাকা-১০০০
www.dpdt.gov.bd

Publication of Filed Patent Application
Publication No: 33 & Date: 21 June 2026

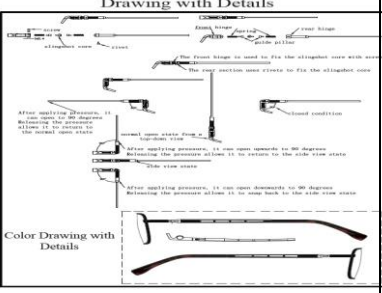
(11) Patent registration No and date , (21) Appl. No. BD-P-2024-303 (22) Filed: 08/10/2024
(23) Priority Data: N/A
(71) Applicant: Mazen (Bangladesh) Industries Limited of Plot# 2-21 & 53-55, Sector#3, Uttara EPZ, Nilphamari, Nationality -Bangladesh
(72) Inventors: (1) Mr. PETER CHANG of Plot# 2-21 & 53-55, Sector#3, Uttara EPZ, Nilphamari, Bangladesh Nationality -China
(51) INT. CL. : G02C 5/14
(54) Invention Title: 360°SPRING TEMPLE
(57) Abstract Introduction – In the world lots of optical producing companies are using for making frames. But no one invented 360° Spring Temple before MAZAN (BANGLADESH) INDUSTRIES LIMITED. It is a unique innovation with some special quality. So it is important for us to do PATENT. The main argument of the claim is – Enhanced Range of Motion : The hinge allows the temple (arm) to move in multiple directions, including forward and backward, and sometimes even allowing it to rotate completely around the hinge point. This flexibility can help prevent breakage when the temples are bent in unusual directions. Spring Mechanism : The spring in the hinge allows the temples to extend outward and snap back into place. This can help the glasses fit more comfortably on a wider range of head sizes and reduce pressure on the temples, providing a more secure and comfortable fit. Durability : By allowing the temples to flex and move in multiple directions, the hinge reduces the likelihood of damage from everyday use, such as putting on or taking off the glasses with one hand or accidentally sitting on them. Methodology – Attach the Hinge (spring core, Nail Pin, spring, Nail button) to the End Piece and temple then connected by a screw to forming a 360 degree spring hinge temple. A 360-degree spring hinge temple on eyeglasses provides enhanced flexibility and durability. Results – This is the combination of front hinge and temple hinge attached with slingshot core and screw, our temples rotate a full 360 degrees, and it's easy to twist advanced memory metal lets our bridges bend and twist and return to their original shape.



গণপ্রজাতন্ত্রী বাংলাদেশ সরকার
পেটেন্ট, শিল্প-নকশা ও ট্রেডমার্কস অধিদপ্তর
শিল্প মন্ত্রণালয়
৯১, মতিঝিল বা/এ, ঢাকা-১০০০
www.dpdt.gov.bd

Publication of Filed Patent Application
Publication No: 33 & Date: 21 June 2026

(11) Patent registration No and date , (21) Appl. No. BD-P-2024-304 (22) Filed: 14/10/2024	
(23) Priority Data: United States of America, Number :18388410, Date : 09-11-2023.	
(71) Applicant: GELMART INDUSTRIES, INC. of 48 W 38 Street, New York, New York 10018, Nationality -United States of America	
(72) Inventors: (1) Eve Bastug of North Haledon, NJ, United States of America Nationality -United States of America, (2) Giancarlo Delevati of New York, NY, United States of America Nationality -United States of America, (3) Yoseph Nasser of New York, NY, United States of America Nationality -United States of America	
(74) Agent : SUPREMEiP Law Firm, 121 Motijheel C/A (1st Floor), Dhaka-1000, Bangladesh	
(51) INT. CL. : A41C 3/14	
(54) Invention Title: SUSTAINABLE BRA GARMENT AND IMPROVED BIO-BASED OPEN CELL FOAM PAD PORTIONS	
(57) Abstract A sustainable bra garment that includes first and second cup portions that are formed of one or more recycled flexible materials and first and second side wing panels that extend from the first and second cup portions, respectively, and having first and second cushioning support pads formed of a bio-based foam material having a very soft open cell structure. The first and second side wing panels are formed of one or more recycled flexible materials. First and second cushioning support pads are configured to be coupled with the first and second cup portions, respectively, each of the pads has front and back surfaces. The front surface of each pad has a generally convex shape and the back surface of each pad has a generally concave shape. Each of the pads is formed of a bio-based material, such as a sugar cane-based open cell foam material, that has hardness and density values that provide both cushioning and support to breasts of a wearer of the sustainable bra garment. The cushioning support pads may be used with a bra garment or with other garments such as swimwear and other apparel where bra support pads can be incorporated.	



গণপ্রজাতন্ত্রী বাংলাদেশ সরকার
পেটেন্ট, শিল্প-নকশা ও ট্রেডমার্কস অধিদপ্তর
শিল্প মন্ত্রণালয়
৯১, মতিঝিল বা/এ, ঢাকা-১০০০
www.dpdt.gov.bd

Publication of Filed Patent Application
Publication No: 33 & Date: 21 June 2026

(11) Patent registration No and date , (21) Appl. No. BD-P-2024-305 (22) Filed: 16/10/2024
(23) Priority Data: United States of America, Number :63595581, Date : 02-11-2023.
(71) Applicant: Nokia Technologies Oy of Karakaari 7, 02610 Espoo, Nationality -Finland
(72) Inventors: (1) Mads LAURIDSEN of Nørgårdsvej 4B, Gistrup, 9260, Denmark Nationality -Denmark, (2) Rafhael MEDEIROS DE AMORIM of Thorsgade 28, Aalborg, 9000, Denmark Nationality -Brazil
(74) Agent : REMFRY & SON LIMITED, 56, NEW ESKATON ROAD 4TH FLOOR, DHAKA-1000, DHAKA, Bangladesh
(51) INT. CL. : G01S 5/14
(54) Invention Title: ADAPTING RADIO MEASUREMENTS BASED ON A GLOBAL NAVIGATION SATELLITE SYSTEM MEASUREMENT GAP
(57) Abstract A method is provided that includes acquiring radio measurements associated with a non-terrestrial network (NTN) in a telecommunications system, during an evaluation period. The method includes performing a global navigation satellite system (GNSS) measurement to determine location information on which uplink transmissions to the NTN are based, the GNSS measurement associated with a GNSS measurement gap. The method includes performing a comparison of a duration of the GNSS measurement gap to a threshold duration. And the method includes performing an evaluation on the radio measurements based on the comparison.

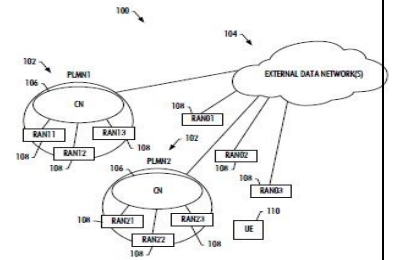

FIG. 1



গণপ্রজাতন্ত্রী বাংলাদেশ সরকার
পেটেন্ট, শিল্প-নকশা ও ট্রেডমার্কস অধিদপ্তর
শিল্প মন্ত্রণালয়
৯১, মতিঝিল বা/এ, ঢাকা-১০০০
www.dpdt.gov.bd

Publication of Filed Patent Application
Publication No: 33 & Date: 21 June 2026

(11) Patent registration No and date , (21) Appl. No. BD-P-2024-307 (22) Filed: 17/10/2024	
(23) Priority Data: Germany, Number :1020231304402, Date : 03-11-2023.	
(71) Applicant: EnPV GmbH of Durlacher Allee 93, 76131, Karlsruhe, Nationality -Germany	
(72) Inventors: (1) Erik Hoffmann of Im Wolbusch 39e, 70499, Stuttgart, Germany Nationality -Germany	
(74) Agent : SUPREMEiP Law Firm, 121 Motijheel C/A (1st Floor), Dhaka-1000, Bangladesh	
(51) INT. CL. : F24S 23/00	
(54) Invention Title: BACK-CONTACT SOLAR CELL AND METHOD FOR PRODUCING A BACK-CONTACT SOLAR CELL	
(57) Abstract The invention relates to a back-contact solar cell (10) having the features of claim 1 and to a method for producing such a back-contact solar cell (10).	



গণপ্রজাতন্ত্রী বাংলাদেশ সরকার
 পেটেন্ট, শিল্প-নকশা ও ট্রেডমার্কস অধিদপ্তর
 শিল্প মন্ত্রণালয়
 ৯১, মতিঝিল বা/এ, ঢাকা-১০০০
www.dpd.gov.bd

Publication of Filed Patent Application
Publication No: 33 & Date: 21 June 2026

(11) Patent registration No and date ,	
(21) Appl. No. BD-P-2024-308	
(22) Filed: 20/10/2024	
(23) Priority Data: China, Number :2023129751, Date : 03-11-2023.	
(71) Applicant: Nokia Technologies Oy of Karakaari 7, 02610 Espoo, Nationality -Finland	
(72) Inventors: (1) Mads LAURIDSEN of Nørgårdsvej 4B, Gistrup, 9260, Denmark Nationality -Denmark, (2) Ping YUAN of Room 1805, Building 24, ANHUAXILI DISTRICT1, Chaoyang, Beijing, 100011, China Nationality -China, (3) Jing Yuan SUN of 1601, Building No 4, Block 6 Hepingli, Dongcheng District, Beijing , China Nationality -China	
(74) Agent : REMFRY & SON LIMITED, 56, NEW ESKATON ROAD 4TH FLOOR, DHAKA-1000, DHAKA, Bangladesh	
(51) INT. CL. : H04W 72/04	
(54) Invention Title: DEVICES, METHODS, APPARATUSES, AND COMPUTER READABLE MEDIA FOR UPLINK TRANSMISSION DURATION EXTENSION	
(57) Abstract Disclosed are devices, methods, apparatuses, and computer readable media for uplink transmission duration extension. An example apparatus for a terminal device may include at least one processor and at least one memory. The at least one memory may store instructions that, when executed by the at least one processor, may cause the terminal device at least to: receive from a network device, at least one first indication indicating whether allowing the terminal device to extend an uplink transmission duration, during which uplink transmission is allowed, after expiry of a position validity duration; and perform one of the following: extending the uplink transmission duration according to the at least one first indication if the at least one first indication allows the terminal device to extend the uplink transmission duration, until receiving from the network device a second indication indicating the terminal device to stop the uplink transmission duration, or extending the uplink transmission duration according to each of received multiple first indications if said each of the received multiple first indications allows the terminal device to extend the uplink transmission duration, and stopping the uplink transmission duration when the uplink transmission duration extended according to said each of the first indications expires.	<p>The diagram illustrates the interaction between a UE 110 and a Network device 110 in a connected mode. It shows two scenarios for uplink transmission duration extension. In the first scenario, the UE receives a first indication (152) in TAC 154, MAC CE 156, or RRC message 158, which allows it to extend its uplink transmission duration (112). After this extension, it receives a second indication (162) in TAC 164, MAC CE 166, or RRC message 168, which instructs it to stop the uplink transmission duration (114). In the second scenario, the UE receives multiple first indications (122) and extends its uplink transmission duration (124) accordingly. It then receives a second indication (126) in TAC 128, MAC CE 130, or RRC message 132, which instructs it to stop the uplink transmission duration (124). Both scenarios conclude with the UE performing periodic position measurements (116, 126) and autonomously performing position measurements (118, 130) before entering idle or inactive mode (118, 130).</p>



গণপ্রজাতন্ত্রী বাংলাদেশ সরকার
পেটেন্ট, শিল্প-নকশা ও ট্রেডমার্কস অধিদপ্তর
শিল্প মন্ত্রণালয়
৯১, মতিঝিল বা/এ, ঢাকা-১০০০
www.dpdt.gov.bd

Publication of Filed Patent Application
Publication No: 33 & Date: 21 June 2026

(11) Patent registration No and date , (21) Appl. No. BD-P-2024-309 (22) Filed: 21/10/2024	
(23) Priority Data: China, Number :2023129457, Date : 02-11-2023.	
(71) Applicant: Nokia Technologies Oy of Karakaari 7, 02610 Espoo, Nationality -Finland	
(72) Inventors: (0) Ahlem KHLASS of 12 rue Jean Bart, Massy, 91300, France Nationality -France, (1) Naizheng ZHENG of Room-404, Building-3, No.60 GuangAnMen NanJie, XichengDistrict, Beijing, 100054, China Nationality - China, (2) Matha DEGHEL of 5 rue Radiguy, Montrouge, 92120, France Nationality -France, (3) Chunli WU of No.1 Wangjing East Road, Chaoyang, Beijing, 100102, China Nationality -China	
(74) Agent : REMFRY & SON LIMITED, 56, NEW ESKATON ROAD 4TH FLOOR, DHAKA-1000, DHAKA, Bangladesh	
(51) INT. CL. : H04W 48/12	
(54) Invention Title: CELL OFF INDICATION VIA DOWNLINK CONTROL INFORMATION	
(57) Abstract The present disclosure relates to a solution on cell off indication via DCI. In particular, a group common DCI format is used to indicate an activation/deactivation of the cell off for entering NES mode. DCI in the group common DCI format may include separate bits for a first indication regarding the activation/deactivation of the cell off for entering NES mode and a second indication regarding the activation/deactivation of cell DTX/DRX. Alternatively, the DCI may include common bits for the first and second indications with a flag to indicate which indication. In this way, the cell off for entering NES mode can be indicated more efficiently.	<p>FIG. 1</p>



গণপ্রজাতন্ত্রী বাংলাদেশ সরকার
পেটেন্ট, শিল্প-নকশা ও ট্রেডমার্কস অধিদপ্তর
শিল্প মন্ত্রণালয়
৯১, মতিঝিল বা/এ, ঢাকা-১০০০
www.dpd.gov.bd

**Publication of Filed Patent Application
Publication No: 33 & Date: 21 June 2026**

(11) Patent registration No and date , (21) Appl. No. BD-P-2024-310 (22) Filed: 21/10/2024	
(23) Priority Data: United Kingdom, Number :23166614, Date : 31-10-2023.	
(71) Applicant: Nokia Technologies Oy of Karakaari 7, 02610 Espoo, Nationality -Finland	
(72) Inventors: (0) Mohamed Amin NASSAR of Vorhoelzerstrasse 3, Munich, 81477, Germany Nationality -Egypt, (1) Sung Hwan WON of 1250 Mourning Dove Dr, Flower Mound, Texas, 75028, United States of America Nationality - Republic of Korea, (2) Ioannis MOUROULIS of Ifigeneias 10 Lagonissi, Athens,19010, Greece Nationality -Greece	
(74) Agent : REMFRY & SON LIMITED, 56, NEW ESKATON ROAD 4TH FLOOR, DHAKA-1000, DHAKA, Bangladesh	
(51) INT. CL. : H04L 65/1083	
(54) Invention Title: URSP EVALUATION FOR UNKNOWN PDU SESSION TYPE	
(57) Abstract A method includes transmitting, by a user equipment (UE), a first message to a first apparatus, the first message including a request to establish communication based on a first communication session type and a first set of one or more session attributes associated with the first message. The UE receives a second message from the first apparatus, the second message including an indication that the request to establish communication using the first communication session type is rejected, and after the receiving the second message, removes from use, a retransmission of the first communication session type and the first set of one or more session attributes for establishing communication, and transmits a third message to the first apparatus or a second apparatus, the third message including a request for communication based on a second communication session type and a second set of one or more session attributes, associated with the third message, wherein a first combination including the first communication session type and the first set of one or more session attributes, is not identical to a second combination including the second communication session type and the second set of one or more session attributes.	<p>FIG. 1</p>



গণপ্রজাতন্ত্রী বাংলাদেশ সরকার
পেটেন্ট, শিল্প-নকশা ও ট্রেডমার্কস অধিদপ্তর
শিল্প মন্ত্রণালয়
৯১, মতিঝিল বা/এ, ঢাকা-১০০০
www.dpdt.gov.bd

Publication of Filed Patent Application
Publication No: 33 & Date: 21 June 2026

(11) Patent registration No and date , (21) Appl. No. BD-P-2024-311 (22) Filed: 22/10/2024	
(23) Priority Data: China, Number :2023228457084, Date : 23-10-2023.	
(71) Applicant: Xiamen Hongfa Electric Power Controls Co., Ltd. of No. 93 Yinong Road, Haicang District, Xiamen, Fujian 361027, Nationality -China	
(72) Inventors:	
(74) Agent : Doulah & Doulah, DOULAH HOUSE (ANNEXE) PLOT-153/2, ROAD-2/2, BLOCK- A, SEC.-12, MIRPUR, DHAKA-1216, Bangladesh	
(51) INT. CL. : F16F 6/00	
(54) Invention Title: COMPRESSION SPRING AND MAGNETIC LATCHING RELAY	
(57) Abstract The Present disclosure provides a compression spring and a magnetic latching relay. The compression spring includes a fixed portion and an elastic portion. The elastic portion is connected to the fixed portion, an angle is formed between the elastic portion and the fixed portion, and the angle is an obtuse angle. The elastic portion has at least one bending structure. According to the compression spring of the embodiment of the present disclosure, the elastic coefficient of the elastic part can be reduced by arranging the bending structure. When the compression spring is applied to a relay and a short-circuit current flows in the relay, a tilting of the compression spring can be avoided, and the stability of a connecting state of the relay can be maintained.	



গণপ্রজাতন্ত্রী বাংলাদেশ সরকার
পেটেন্ট, শিল্প-নকশা ও ট্রেডমার্কস অধিদপ্তর
শিল্প মন্ত্রণালয়
৯১, মতিঝিল বা/এ, ঢাকা-১০০০
www.dpdt.gov.bd

Publication of Filed Patent Application
Publication No: 33 & Date: 21 June 2026

(11) Patent registration No and date , (21) Appl. No. BD-P-2024-312 (22) Filed: 22/10/2024	
(23) Priority Data: China, Number :2023113786539, Date : 23-10-2023.	
(71) Applicant: Xiamen Hongfa Electric Power Controls Co., Ltd. of No. 93 Yinong Road, Haicang District, Xiamen, Fujian 361027, Nationality -China	
(72) Inventors:	
(74) Agent : Doulah & Doulah, DOULAH HOUSE (ANNEXE) PLOT-153/2, ROAD-2/2, BLOCK- A, SEC.-12, MIRPUR, DHAKA-1216, Bangladesh	
(51) INT. CL. : G05F 1/325	
(54) Invention Title: LEAD-OUT STRUCTURE AND MAGNETIC LATCHING RELAY	
(57) Abstract The embodiment of the disclosure provides a lead-out structure and a magnetic latching relay. The lead-out structure includes a lead-out part and at least one auxiliary part. The lead-out part includes a first lead-out part and a second lead-out part, one end of the second lead-out part is connected to one side of the first lead-out part. In a width direction of the lead-out part, the width of the second lead-out part is smaller than the width of the first lead-out part. The first lead-out part is used to electrically connect to the static contact portion of a relay. At least one auxiliary part is fixedly connected to the second lead-out part. Wherein the lead-out part is formed by a stamping process, and the auxiliary part is formed by using a remaining material after the lead-out part is formed by the stamping process. The lead-out structure of the invention can simplify the manufacturing process, reduce the impedance of the load circuit, increase the current-carrying area, reduce the temperature rise, save materials and reduce the cost.	



গণপ্রজাতন্ত্রী বাংলাদেশ সরকার
পেটেন্ট, শিল্প-নকশা ও ট্রেডমার্কস অধিদপ্তর
শিল্প মন্ত্রণালয়
৯১, মতিঝিল বা/এ, ঢাকা-১০০০
www.dpdt.gov.bd

Publication of Filed Patent Application
Publication No: 33 & Date: 21 June 2026

(11) Patent registration No and date , (21) Appl. No. BD-P-2024-313 (22) Filed: 22/10/2024
(23) Priority Data: China, Number :2023113770456, Date : 23-10-2023.
(71) Applicant: Xiamen Hongfa Electric Power Controls Co., Ltd. of No. 93 Yinong Road, Haicang District, Xiamen, Fujian 361027, Nationality -China
(72) Inventors:
(74) Agent : Doulah & Doulah, DOULAH HOUSE (ANNEXE) PLOT-153/2, ROAD-2/2, BLOCK- A, SEC.-12, MIRPUR, DHAKA-1216, Bangladesh
(51) INT. CL. : G05F 1/325
(54) Invention Title: MAGNETIC LATCHING RELAY
(57) Abstract The embodiment of the disclosure provides a magnetic latching relay including a base; a contact structure located on the base, the contact structure has a first end and a second end in the transverse direction, the first end is provided with a first contact set, the second end is provided with a second contact set; a first static lead-out piece, one end of the first static lead-out piece is connected to the first end, and another end of the first static lead-out piece extends out from a bottom of the base along a vertical direction of the base; and a coil module and a magnetic circuit structure, disposed on the base and located on one side of the contact structure in a longitudinal direction; when an impulse voltage is applied to the coil module, the magnetic circuit structure and the coil module can form a constant magnetic field, and a first centerline of the constant magnetic field in the longitudinal direction deviates from a second centerline between the first contact set and the second contact set and is closer to the second contact set, so that the constant magnetic field is away from the first static lead-out piece. The magnetic latching relay is of high stability.

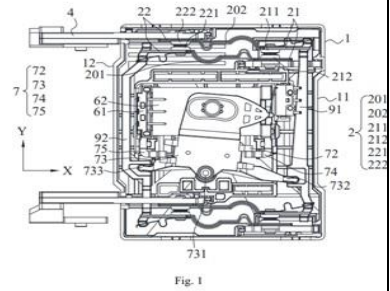



গণপ্রজাতন্ত্রী বাংলাদেশ সরকার
পেটেন্ট, শিল্প-নকশা ও ট্রেডমার্কস অধিদপ্তর
শিল্প মন্ত্রণালয়
৯১, মতিঝিল বা/এ, ঢাকা-১০০০
www.dpdt.gov.bd

Publication of Filed Patent Application
Publication No: 33 & Date: 21 June 2026

(11) Patent registration No and date , (21) Appl. No. BD-P-2024-314 (22) Filed: 22/10/2024
(23) Priority Data: China, Number :2023113788375, Date : 23-10-2023.
(71) Applicant: Xiamen Hongfa Electric Power Controls Co., Ltd. of No. 93 Yinong Road, Haicang District, Xiamen, Fujian 361027, Nationality -China
(72) Inventors:
(74) Agent : Doulah & Doulah, DOULAH HOUSE (ANNEXE) PLOT-153/2, ROAD-2/2, BLOCK- A, SEC.-12, MIRPUR, DHAKA-1216, Bangladesh
(51) INT. CL. : G05F 1/325
(54) Invention Title: MAGNETIC LATCHING RELAY
(57) Abstract The disclosure provides a magnetic latching relay including a base; a contact structure located on the base, the contact structure has a first end and a second end in the transverse direction, the first static lead-out piece includes a first lead-out part connected to the first end of the contact structure and a second lead-out part, the second lead-out part is connected to the first lead-out part, and extends out from a bottom of the base along a vertical direction of the base, the first lead-out part has a guiding groove, the guiding groove extends from one side of the first lead-out part close to the second end along a transverse direction and does not penetrate the first lead-out part, and an opening of the guiding groove faces the second end of the contact structure; and a coil module and a magnetic circuit structure disposed on the base and located on one side of the contact structure in a longitudinal direction. The magnetic latching relay is of high stability.

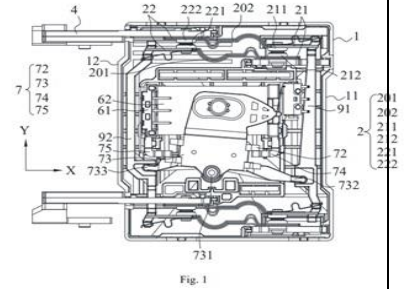



গণপ্রজাতন্ত্রী বাংলাদেশ সরকার
পেটেন্ট, শিল্প-নকশা ও ট্রেডমার্কস অধিদপ্তর
শিল্প মন্ত্রণালয়
৯১, মতিঝিল বা/এ, ঢাকা-১০০০
www.dpdt.gov.bd

Publication of Filed Patent Application
Publication No: 33 & Date: 21 June 2026

(11) Patent registration No and date , (21) Appl. No. BD-P-2024-315 (22) Filed: 22/10/2024	
(23) Priority Data: China, Number :2023228480790, Date : 23-10-2023.	
(71) Applicant: Xiamen Hongfa Electric Power Controls Co., Ltd. of No. 93 Yinong Road, Haicang District, Xiamen, Fujian 361027, Nationality -China	
(72) Inventors:	
(74) Agent : Doulah & Doulah, DOULAH HOUSE (ANNEXE) PLOT-153/2, ROAD-2/2, BLOCK- A, SEC.-12, MIRPUR, DHAKA-1216, BANGLADESH, DHAKA, Bangladesh	
(51) INT. CL. : G05F 1/325	
(54) Invention Title: MAGNETIC LATCHING RELAY	
(57) Abstract The present disclosure provides a magnetic latching relay, including a base, a microswitch and a magnetic circuit structure. The microswitch is disposed on the base and includes a housing and an elastic sheet, the elastic sheet extending from the housing in a direction away from the housing. The magnetic circuit structure includes an armature, a permanent magnet, and an injection molded part. The injection molded part includes: a body portion wrapped around the permanent magnet and a part of the armature, to enable the permanent magnet to swing; and a toggle portion, integrally injection molded with the body portion and having a protrusion protruding towards the elastic sheet. When the permanent magnet swings towards a direction close to the microswitch, the protrusion moves towards a direction close to the elastic sheet, and drives the elastic sheet to move towards a direction close to the housing, making the microswitch connected. When the permanent magnet swings towards a direction away from the microswitch, the protrusion moves towards a direction away from the elastic sheet, and the elastic sheet is reset, making the microswitch disconnected. The magnetic latching relay of the present disclosure enables more accurate monitoring of the microswitch, and can extend the service life and save space.	



গণপ্রজাতন্ত্রী বাংলাদেশ সরকার
 পেটেন্ট, শিল্প-নকশা ও ট্রেডমার্কস অধিদপ্তর
 শিল্প মন্ত্রণালয়
 ৯১, মতিঝিল বা/এ, ঢাকা-১০০০
www.dpdt.gov.bd

Publication of Filed Patent Application
Publication No: 33 & Date: 21 June 2026

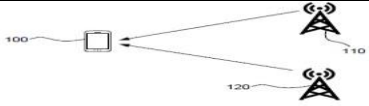
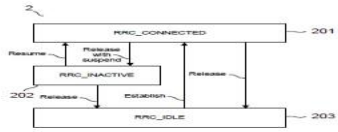
(11) Patent registration No and date , (21) Appl. No. BD-P-2024-316 (22) Filed: 22/10/2024	
(23) Priority Data: United Kingdom, Number :23172257, Date : 10-11-2023.	
(71) Applicant: Nokia Technologies Oy of Karakaari 7, 02610 Espoo, Nationality -Finland	
(72) Inventors: (1) Tero HENTTONEN of Joupinkuja 4 A 5, Espoo, 02760, Finland Nationality -Finland, (2) Ali KARIMIDEHKORDI of Rabenkopfstr. 41, Munich, 81545, Germany Nationality -Iran (Islamic Republic of), (3) Lars DALSGAARD of Torpantie 56, Oulu, 90230, Finland Nationality -Denmark, (4) Riikka Karoliina DIMNIK of Lohansuontie 7 L, Kirkkonummi, 02880, Finland Nationality -Finland, (5) Jani-Pekka KAINULAINEN of 3 Peacock Close, Cottenham, CB24 8BA, United Kingdom Nationality -Finland	
(74) Agent : REMFRY & SON LIMITED, 56, NEW ESKATON ROAD 4TH FLOOR, DHAKA-1000, DHAKA, Bangladesh	
(51) INT. CL. : H04W 28/18	
(54) Invention Title: Methods and Apparatuses Relating to Wireless Communication	
(57) Abstract This specification describes a terminal device comprising: means for receiving, at the terminal device from at least one base station of a telecommunications network, configuration information which is indicative of a modified configuration for a measurement validity duration pre-configured at the terminal device, wherein the measurement validity duration is for use in validating measurements of signals received from at least one cell of the telecommunications network performed by the terminal device in an idle mode or an inactive mode; and means for determining whether to follow the modified configuration for the measurement validity duration or the pre-configured measurement validity duration	 <p>FIG. 1</p>  <p>FIG. 2</p>



গণপ্রজাতন্ত্রী বাংলাদেশ সরকার
পেটেন্ট, শিল্প-নকশা ও ট্রেডমার্কস অধিদপ্তর
শিল্প মন্ত্রণালয়
৯১, মতিঝিল বা/এ, ঢাকা-১০০০
www.dpdt.gov.bd

Publication of Filed Patent Application
Publication No: 33 & Date: 21 June 2026

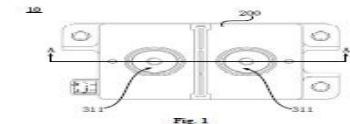
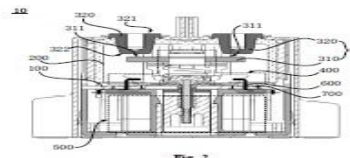
(11) Patent registration No and date , (21) Appl. No. BD-P-2024-317 (22) Filed: 24/10/2024	
(23) Priority Data: China, Number :2023113945037, Date : 25-10-2023.	
(71) Applicant: Xiamen Hongfa Electric Power Controls Co., Ltd. of No. 93 Yinong Road, Haicang District, Xiamen, Fujian 361027, Nationality -China	
(72) Inventors:	
(74) Agent : DOULAH & DOULAH, DOULAH HOUSE (ANNEXE) PLOT-153/2, ROAD-2/2 BLOCK-A SECTION-12 MIRPUR, DHAKA-1216, DHAKA, Bangladesh	
(51) INT. CL. : F21K 9/90	
(54) Invention Title: PUSH ROD ASSEMBLY, MANUFACTURING METHOD THEREOF AND RELAY	
(57) Abstract The present disclosure relates to the technical field of electronic control devices, specifically to a push rod assembly, a manufacturing method thereof and a relay. The push rod assembly includes a push rod (410), an auxiliary movable contact part (420) and an isolation cover (430). The auxiliary movable contact part (420) includes an auxiliary movable contact piece (421) and an auxiliary movable contact (422) provided on an end portion of the auxiliary movable contact piece (421). The isolation cover (430) is connected to the push rod (410) and the auxiliary movable contact piece (421), so as to follow the push rod (410). The isolation cover (430) covers the auxiliary movable contact (422) to isolate the auxiliary movable contact (422) from a main movable contact part (310). The isolation cover (430) is configured to extend a creepage distance from the main movable contact part (310) to the auxiliary movable contact part (420).	
 Fig. 1	
 Fig. 2	



গণপ্রজাতন্ত্রী বাংলাদেশ সরকার
পেটেন্ট, শিল্প-নকশা ও ট্রেডমার্কস অধিদপ্তর
শিল্প মন্ত্রণালয়
৯১, মতিঝিল বা/এ, ঢাকা-১০০০
www.dpdt.gov.bd

Publication of Filed Patent Application
Publication No: 33 & Date: 21 June 2026

(11) Patent registration No and date , (21) Appl. No. BD-P-2024-318 (22) Filed: 24/10/2024
(23) Priority Data: European Patent Office (EPO), Number :232059964, Date : 26-10-2023.
(71) Applicant: SYNGENTA CROP PROTECTION AG of Rosentalstrasse 67, 4058 Basel, Nationality -Switzerland
(72) Inventors: (1) LOISELEUR, Olivier of Syngenta Crop Protection AG; Schaffhauserstrasse, 4332 Stein, Switzerland Nationality -France, (2) DRAKOPOULOS, Dimitrios of Syngenta Crop Protection AG; Schaffhauserstrasse, 4332 Stein, Switzerland Nationality -Greece
(74) Agent : Advanced IP Law Firm, Suite#9/C (9th Floor), Fahima Tower, 42-43, Purana Paltan, Dhaka-1000, Bangladesh
(51) INT. CL. : C12Q 1/6895
(54) Invention Title: METHOD OF CONTROLLING PHYTOPATHOGENIC FUNGI
(57) Abstract The present disclosure relates to a method of controlling or preventing phytopathogenic diseases or phytopathogenic fungi on plant propagation material, the method comprising applying to the plant propagation material, a composition comprising at least a component (A), wherein compound (A) comprises jawsamycin according to following formula (IIa): (IIa) . , preferably in a fungicidally effective amount.



গণপ্রজাতন্ত্রী বাংলাদেশ সরকার
 পেটেন্ট, শিল্প-নকশা ও ট্রেডমার্কস অধিদপ্তর
 শিল্প মন্ত্রণালয়
 ৯১, মতিঝিল বা/এ, ঢাকা-১০০০
www.dpdt.gov.bd

Publication of Filed Patent Application
Publication No: 33 & Date: 21 June 2026

(11) Patent registration No and date ,	
(21) Appl. No. BD-P-2024-319	
(22) Filed: 30/10/2024	
(23) Priority Data:	
United States of America, Number :63595673, Date : 02-11-2023.	
(71) Applicant: Nokia Technologies Oy of Karakaari 7, 02610 Espoo, Nationality -Finland	
(72) Inventors: (0) Sanjay GOYAL of 304 Dalton Ct, Denville, New Jersey, 07834, United States of America Nationality -India, (1) Timo KOSKELA of Suojuoksuntie 2 B 7, Oulu, 90670, Finland Nationality -Finland	
(74) Agent : REMFRY & SON LIMITED, 56, NEW ESKATON ROAD 4TH FLOOR, DHAKA-1000, DHAKA, Bangladesh	
(51) INT. CL. : H04W 24/10	
(54) Invention Title: METHODS FOR MEASUREMENT REPORTING VIA CHANNEL STATE INFORMATION ACTIVATION OR DEACTIVATION	
(57) Abstract	



গণপ্রজাতন্ত্রী বাংলাদেশ সরকার
পেটেন্ট, শিল্প-নকশা ও ট্রেডমার্কস অধিদপ্তর
শিল্প মন্ত্রণালয়
৯১, মতিঝিল বা/এ, ঢাকা-১০০০
www.dpdt.gov.bd

Publication of Filed Patent Application
Publication No: 33 & Date: 21 June 2026

(11) Patent registration No and date , (21) Appl. No. BD-P-2024-320 (22) Filed: 30/10/2024	
(23) Priority Data: China, Number :2023229609597, Date : 01-11-2023.	
(71) Applicant: Xiamen Hongfa Electric Power Controls Co., Ltd. of No.93, Yinong Road, Haicang District, Xiamen, Fujian Province 361027, Nationality -China	
(72) Inventors: (1) DAI, Wenguang of No. 93, Yinong Road, Haicang District, Xiamen, Fujian Province 361027, China Nationality -China, (2) ZHONG, Shuming of No.93, Yinong Road, Haicang District, Xiamen, Fujian Province 361027, China Nationality -China, (3) LI, Fangneng of No.93, Yinong Road, Haicang District, Xiamen, Fujian Province 361027, China Nationality -China, (4) HU, Jianxin of No.93, Yinong Road, Haicang District, Xiamen, Fujian Province 361027, China Nationality -China	
(74) Agent : SUPREMEiP Law Firm, 121 Motijheel C/A (1st Floor), Dhaka-1000, Bangladesh	
(51) INT. CL. : G05F 1/325	
(54) Invention Title: MAGNETIC LATCHING RELAY	
(57) Abstract The present disclosure provides a magnetic latching relay, including a bottom plate, a case, a first lead-out pin, a second lead-out pin, a coil lead-out pin, a magnetic circuit system and a contact system, wherein the contact system uses a double-contact anti-short circuit structure; and the magnetic circuit system and the contact system are cladded in an internal space by the case and the base; the first lead-out pin, the second lead-out pin and the coil lead-out pin are led down through the bottom surface of the base, so as to facilitate a installation and wiring of an electromagnetic relay in a later stage, thereby facilitating the installation and use by the customer. Furthermore, the case is fitted to the base to form an enclosed space, thereby improving the protection of internal devices and improving the adaptability of the electromagnetic relay to a harsh external environment. In addition, after the case is fitted to the base, a sealing process can be performed by dispensing on the bottom surface of the base, thereby further improving the sealing performance of the electromagnetic relay and the adaptability to the external environment.	



গণপ্রজাতন্ত্রী বাংলাদেশ সরকার
পেটেন্ট, শিল্প-নকশা ও ট্রেডমার্কস অধিদপ্তর
শিল্প মন্ত্রণালয়
৯১, মতিঝিল বা/এ, ঢাকা-১০০০
www.dpdt.gov.bd

Publication of Filed Patent Application
Publication No: 33 & Date: 21 June 2026

(11) Patent registration No and date , (21) Appl. No. BD-P-2024-321 (22) Filed: 30/10/2024	
(23) Priority Data: China, Number :2023229617199, Date : 01-11-2023.	
(71) Applicant: Xiamen Hongfa Electric Power Controls Co., Ltd. of No.93, Yinong Road, Haicang District, Xiamen, Fujian Province 361027, Nationality -China	
(72) Inventors: (1) DAI, Wenguang of No. 93, Yinong Road, Haicang District, Xiamen, Fujian Province 361027, China Nationality -China, (2) ZHONG, Shuming of No.93, Yinong Road, Haicang District, Xiamen, Fujian Province 361027, China Nationality -China, (3) LI, Fangneng of No.93, Yinong Road, Haicang District, Xiamen, Fujian Province 361027, China Nationality -China, (4) HU, Jianxin of No.93, Yinong Road, Haicang District, Xiamen, Fujian Province 361027, China Nationality -China	
(74) Agent : SUPREMEiP Law Firm, 121 Motijheel C/A (1st Floor), Dhaka-1000, Bangladesh	
(51) INT. CL. : H01H 1/00	
(54) Invention Title: SWITCHING DEVICE	
(57) Abstract The present disclosure provides a switching device, including a contact system. The contact system includes two contact sets, where the two contact sets comprise an arc resistant end contact set and a current carrying end contact set, and each of the two contact sets comprises at least one pair of movable and stationary contacts; when the contact system is disconnected, a gap between the movable and stationary contacts of the arc resistant end contact set is less than a gap between the movable and stationary contacts of the current carrying end contact set, wherein a periphery of the arc resistant end contact set is provided with a permanent magnet. By designing the contact system with an anti-short circuit structure of a double-contact parallel circuit, a technical effect of magnetic blowing to extinguish the arc can be achieved on the basis of being able to carry a large current without arranging the permanent magnet at the periphery of each contact set of the double contact sets, thereby simplifying the structure of a relay, saving raw materials and making the layout of the relay more compact.	



গণপ্রজাতন্ত্রী বাংলাদেশ সরকার
পেটেন্ট, শিল্প-নকশা ও ট্রেডমার্কস অধিদপ্তর
শিল্প মন্ত্রণালয়
৯১, মতিঝিল বা/এ, ঢাকা-১০০০
www.dpdt.gov.bd

Publication of Filed Patent Application
Publication No: 33 & Date: 21 June 2026

(11) Patent registration No and date , (21) Appl. No. BD-P-2024-322 (22) Filed: 03/11/2024	
(23) Priority Data: China, Number :2024107009867, Date : 31-05-2024.	
(71) Applicant: CRRC Taiyuan Co., Ltd of No.129 Xinghua West Street, Wanbailin District Taiyuan, Shanxi 030027, Nationality -China	
(72) Inventors:	
(74) Agent : Associate Intellectual Property Law Firm (AIPLF), Chameli bagh no-1, 9th floor, Romna, Shantinagar, Dhaka , Bangladesh	
(51) INT. CL. : B60H 1/00	
(54) Invention Title: A BALLAST REGULATOR VEHICLE AIR CONTROL SYSTEM AND BALLAST REGULATOR VEHICLE	
(57) Abstract The invention relates to the technical field of railway wagon, and provides an air control pipeline system for a ballast regulator, comprising: a four-way joint, wherein the first port of the four- way joint is connected to the main air supply unit of the ballast regulator, the second port of the four-way joint is connected to the bottom door control unit, the third port of the four-way joint is connected to the air storage unit, and the fourth port of the four-way joint is connected to the pressure measurement unit. A single four-way joint replaces the existing first and second three-way joints, and the connection branch pipe between the air supply adjustment valve and the first three-way joint is eliminated, thereby reducing the number of flange interfaces. This decreases the probability of air leakage in the pipeline system and reduces the vehicle's manufacturing cost.	



গণপ্রজাতন্ত্রী বাংলাদেশ সরকার
পেটেন্ট, শিল্প-নকশা ও ট্রেডমার্কস অধিদপ্তর
শিল্প মন্ত্রণালয়
৯১, মতিঝিল বা/এ, ঢাকা-১০০০
www.dpdt.gov.bd

Publication of Filed Patent Application
Publication No: 33 & Date: 21 June 2026

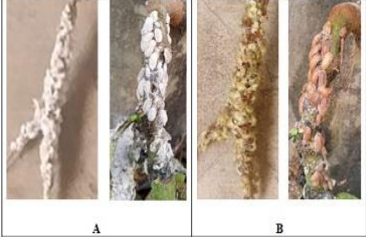
(11) Patent registration No and date , (21) Appl. No. BD-P-2024-323 (22) Filed: 03/11/2024
(23) Priority Data: N/A
(71) Applicant: Registrar of University of Dhaka, Dhaka-1000, Nationality -Bangladesh
(72) Inventors: (1) Dr. Md. Zakir Sultan, Principal Scientist of Centre for Advanced Research in Sciences (CARS), University of Dhaka, Dhaka-1000, Bangladesh Nationality -Bangladesh, (2) Dr. Mohammad A. Rashid, Professor of Department of Pharmaceutical Chemistry, Faculty of Pharmacy, University of Dhaka, Dhaka-1000, Bangladesh Nationality -Bangladesh
(51) INT. CL. : A01P 17/00
(54) Invention Title: A Green Formulation to Control Mealybugs (Pseudococcidae)
(57) Abstract This is an environmental friendly formulation which has been developed from combination of natural resources and environmental friendly solvents. It is highly effective against mealybugs (Pseudococcidae).

Figure 1: (A) Live mealybugs before application of the formulation, (B) Dead mealybugs after application of the formulation.



গণপ্রজাতন্ত্রী বাংলাদেশ সরকার
পেটেন্ট, শিল্প-নকশা ও ট্রেডমার্কস অধিদপ্তর
শিল্প মন্ত্রণালয়
৯১, মতিঝিল বা/এ, ঢাকা-১০০০
www.dpdt.gov.bd

Publication of Filed Patent Application
Publication No: 33 & Date: 21 June 2026

(11) Patent registration No and date , (21) Appl. No. BD-P-2024-324 (22) Filed: 03/11/2024
(23) Priority Data: N/A
(71) Applicant: Kazi Shakhawath Hossain, Professor of Department of Botany, Jagannath University, 9-10, Chittaranjan Avenue, Sutrapur, Dhaka-1100, Nationality -Bangladesh
(72) Inventors: (0) Kazi Shakhawath Hossain, Professor of Department of Botany, Jagannath University, 9-10, Chittaranjan Avenue, Sutrapur, Dhaka-1100, Bangladesh Nationality -Bangladesh, (1) Razia Sultana, PhD student of Department of Botany, Jagannath University, 9-10, Chittaranjan Avenue, Sutrapur, Dhaka-1100, Bangladesh Nationality -Bangladesh
(51) INT. CL. : C09B 5/28
(54) Invention Title: Diphosphoferrous carbazole (an antifungal carbazole derivative)
(57) Abstract



গণপ্রজাতন্ত্রী বাংলাদেশ সরকার
পেটেন্ট, শিল্প-নকশা ও ট্রেডমার্কস অধিদপ্তর
শিল্প মন্ত্রণালয়
৯১, মতিঝিল বা/এ, ঢাকা-১০০০
www.dpdt.gov.bd

Publication of Filed Patent Application
Publication No: 33 & Date: 21 June 2026

(11) Patent registration No and date , (21) Appl. No. BD-P-2024-325 (22) Filed: 03/11/2024											
(23) Priority Data: United States of America, Number :63547254, Date : 03-11-2023. and United States of America, Number :63655542, Date : 03-06-2024. and United States of America, Number :63661523, Date : 18-06-2024.											
(71) Applicant: Cellarity, Inc. of Somerville, Massachusetts, Nationality -United States of America											
(72) Inventors: (1) Robert Brian Nicewonger of c/o Tyngsboro, Massachusetts, United States of America Nationality - United States of America, (2) Mauricio Cortes of c/o Wellesley, Massachusetts, United States of America Nationality - United States of America, (3) Colin Diner of c/o Somerville, Massachusetts, United States of America Nationality - United States of America, (4) Sriram Krishnamoorthy of c/o Acton, Massachusetts, United States of America Nationality -United States of America, (5) Na Li of c/o Winchester, Massachusetts, United States of America Nationality -United States of America, (6) Frank Lovering of c/o Acton, Massachusetts, United States of America Nationality -United States of America, (7) Kristen Marino of c/o Stoneham, Massachusetts, United States of America Nationality -United States of America, (8) Samuel Miller of c/o Cambridge, Massachusetts, United States of America Nationality -United States of America, (9) Qing Tang of c/o Boxborough, Massachusetts, United States of America Nationality -United States of America, (10) Atli Thorarensen of c/o Stow, Massachusetts, United States of America Nationality -United States of America, (11) Ravi Ujjinamatada of c/o Lexington, Massachusetts, United States of America Nationality -United States of America, (12) David Zhang of c/o West Roxbury, Massachusetts, United States of America Nationality -United States of America											
(74) Agent : ISLAM & CO., 19/D (3rdFloor), East Noyatola, Mogh Bazar, Dhaka -1217, Bangladesh											
(51) INT. CL. : C07H 19/16											
(54) Invention Title: Modulators of DCN-1 and Methods of Use Thereof											
(57) Abstract The present disclosure provides DCN-1 modulating compounds, pharmaceutically acceptable salts thereof, pharmaceutical compositions, and their use for treating sickle cell disorders, diseases, and conditions. Such compounds are of Formula Ia: Ia or a pharmaceutically acceptable salt thereof.	<table border="1"><caption>FIG. 1A: Total HbF+ in GltA+ cells</caption><thead><tr><th>Group</th><th>Mean HbF+ (%)</th></tr></thead><tbody><tr><td>Control</td><td>~10</td></tr><tr><td>100 nM DCN-100</td><td>~25</td></tr><tr><td>100 nM DCN-1000</td><td>~28</td></tr><tr><td>100 nM DCN-10000</td><td>~35</td></tr></tbody></table>	Group	Mean HbF+ (%)	Control	~10	100 nM DCN-100	~25	100 nM DCN-1000	~28	100 nM DCN-10000	~35
Group	Mean HbF+ (%)										
Control	~10										
100 nM DCN-100	~25										
100 nM DCN-1000	~28										
100 nM DCN-10000	~35										



গণপ্রজাতন্ত্রী বাংলাদেশ সরকার
পেটেন্ট, শিল্প-নকশা ও ট্রেডমার্কস অধিদপ্তর
শিল্প মন্ত্রণালয়
৯১, মতিঝিল বা/এ, ঢাকা-১০০০
www.dpdt.gov.bd

**Publication of Filed Patent Application
Publication No: 33 & Date: 21 June 2026**

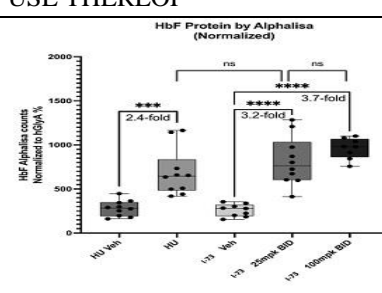
(11) Patent registration No and date ,	
(21) Appl. No. BD-P-2024-326	
(22) Filed: 03/11/2024	
(23) Priority Data:	
United States of America, Number :63547249, Date : 03-11-2023. and United States of America, Number :63618581, Date : 08-01-2024. and United States of America, Number :63655541, Date : 03-06-2024. and United States of America, Number :63661551, Date : 18-06-2024. and United States of America, Number :63682745, Date : 13-08-2024.	
(71) Applicant: Cellarity, Inc. of Somerville, Massachusetts, Nationality -United States of America	
(72) Inventors: (1) Robert Brian Nicewonger of c/o Tyngsboro, Massachusetts, United States of America Nationality - United States of America, (2) Mauricio Cortes of c/o Wellesley, Massachusetts, United States of America Nationality - United States of America, (3) Colin Diner of c/o Somerville, Massachusetts, United States of America Nationality - United States of America, (4) Sriram Krishnamoorthy of c/o Acton, Massachusetts, United States of America Nationality -United States of America, (5) Na Li of c/o Winchester, Massachusetts, United States of America Nationality -United States of America, (6) Frank Lovering of c/o Acton, Massachusetts, United States of America Nationality -United States of America, (7) Kristen Marino of c/o Stoneham, Massachusetts, United States of America Nationality -United States of America, (8) Samuel Miller of c/o Cambridge, Massachusetts, United States of America Nationality -United States of America, (9) Qing Tang of c/o Boxborough, Massachusetts, United States of America Nationality -United States of America, (10) Atli Thorarensen of c/o Stow, Massachusetts, United States of America Nationality -United States of America, (11) Ravi Ujjanmatada of c/o Lexington, Massachusetts, United States of America Nationality -United States of America, (12) David Zhang of c/o West Roxbury, Massachusetts, United States of America Nationality -United States of America, (13) Ragy Haddad of c/o Cambridge, Massachusetts, United States of America Nationality -United States of America	
(74) Agent : ISLAM & CO., 19/D (3rdFloor), East Noyatola, Mogh Bazar, Dhaka -1217, Bangladesh	
(51) INT. CL. : C07H 19/16	
(54) Invention Title: DCN-1 MODULATING COMPOUNDS AND METHODS OF USE THEREOF	
(57) Abstract	
The present disclosure provides DCN-1 modulating compounds, pharmaceutically acceptable salts thereof, pharmaceutical compositions, and their use for treating sickle cell disorders, diseases, and conditions. Such compounds are of Formula I: I or a pharmaceutically acceptable salt thereof.	



গণপ্রজাতন্ত্রী বাংলাদেশ সরকার
পেটেন্ট, শিল্প-নকশা ও ট্রেডমার্কস অধিদপ্তর
শিল্প মন্ত্রণালয়
৯১, মতিঝিল বা/এ, ঢাকা-১০০০
www.dpdt.gov.bd

Publication of Filed Patent Application
Publication No: 33 & Date: 21 June 2026

(11) Patent registration No and date , (21) Appl. No. BD-P-2024-327 (22) Filed: 04/11/2024	
(23) Priority Data: Japan, Number :2023191735, Date : 09-11-2023.	
(71) Applicant: SHIN-ETSU CHEMICAL CO., LTD. of 4-1, Marunouchi 1-chome, Chiyoda-ku, Tokyo 1000005, Nationality -Japan	
(72) Inventors: (1) Junya Fukuda of c/o MMRC, Shin-Etsu Chemical Co., Ltd., 1-5, Kitago 2-chome, Echizen-shi, Fukui 9158515, Japan Nationality -Japan, (2) Tetsuya Kume of c/o MMRC, Shin-Etsu Chemical Co., Ltd., 1-5, Kitago 2-chome, Echizen-shi, Fukui 9158515, Japan Nationality -Japan	
(74) Agent : Munshi & Associates, 194/D/1, Tejkunipara, Tejgaon, Dhaka-1215, Bangladesh	
(51) INT. CL. : F25B 21/00	
(54) Invention Title: RAW MATERIAL ALLOY FOR MAGNETIC REFRIGERATION MATERIAL, PRODUCTION METHOD OF SAME, MAGNETIC REFRIGERATION MATERIAL, AND PRODUCTION METHOD OF SAME	
(57) Abstract To provide a raw material alloy for a magnetic refrigeration material that is capable of controlling the amount of hydrogen adsorbed and homogenizing the distribution of hydrogen concentration on wider hydrogenation conditions than ever before and a production method thereof, and to provide a magnetic refrigeration material that has a high ΔS and a controlled transition temperature and a production method thereof. The raw material alloy for a magnetic refrigeration material of the present invention is represented by a compositional formula of $\text{La}(1-a)\text{Ra}(\text{Fe}(1-b-c-d)\text{TMbSi cAd})z$, contains at least one phase of an (La,R)MSi phase, an (La,R)5M3 phase, an (La,R)6M11Si3 phase, and an (La,R)2M17 phase in a total amount of 0.3% by volume or less as a R-containing subphase, contains an α -Fe phase in an amount of 0.1% by volume or more and 2.2% by volume or less, and contains, as the balance, an (La,R)(Fe,TM,Si,A)13 phase as a main phase. The magnetic refrigeration material of the present invention is obtained by subjecting the raw material alloy for a magnetic refrigeration material of the present invention to a hydrogenation heat treatment.	FIG 1



গণপ্রজাতন্ত্রী বাংলাদেশ সরকার
পেটেন্ট, শিল্প-নকশা ও ট্রেডমার্কস অধিদপ্তর
শিল্প মন্ত্রণালয়
৯১, মতিঝিল বা/এ, ঢাকা-১০০০
www.dpdt.gov.bd

Publication of Filed Patent Application
Publication No: 33 & Date: 21 June 2026

(11) Patent registration No and date , (21) Appl. No. BD-P-2024-329 (22) Filed: 07/11/2024
(23) Priority Data: China, Number :202311495626, Date : 10-11-2023. and European Patent Office (EPO), Number :232089888, Date : 10-11-2023.
(71) Applicant: Archroma International (Germany) GmbH of Rehlinger Straße 1, 86462 Langwied, Nationality - Germany
(72) Inventors: (1) Dr. rer.nat. Johannes Diebler of Graf-Dux Str. 6a, 82278 Althegnenberg, Germany Nationality - Germany, (2) Harshal D. Santan of Jade 12, 2719-RT, Zoetermeer, Netherlands Nationality -India, (3) Tanja Refle of Bürgermeister-Graber-Straße 5, 86494 Emersacker, Germany Nationality -Germany, (4) Günther Tschida of Wertachweg, 86830 Schwabmünchen, Germany Nationality -Germany, (5) Rebika Devi of Vijay vilas Flat no 33, building #3, Ghodbunder Road, Kavesar, Thane West, 400615, Maharastra, India Nationality -India, (6) Dr Khijar Sarnaik of 23 Elias Road, 12-06, Ris Granduer, Singapore 519930, Singapore Nationality -India
(74) Agent : REMFRY & SON LIMITED, 56, NEW ESKATON ROAD 4TH FLOOR, DHAKA-1000, DHAKA, Bangladesh
(51) INT. CL. : C07K 7/04
(54) Invention Title: LINEAR RANDOM SILICONE-POLYETHER COPOLYMERS WITH TERTIARY AMINO LINKS
(57) Abstract The present invention relates to the field of copolymers suitable for textile, more particularly relates to copolymers suitable for textile end finishing products such as softeners. More particularly, the present invention relates to a linear random copolymer which results from the polymerization of silicone monomers, polyglycidyl ether monomers, preferably diglycidyl ether monomers, and secondary amino compounds. The present invention also relates to a method for the preparation of said copolymers and uses of said copolymers.



গণপ্রজাতন্ত্রী বাংলাদেশ সরকার
পেটেন্ট, শিল্প-নকশা ও ট্রেডমার্কস অধিদপ্তর
শিল্প মন্ত্রণালয়
৯১, মতিঝিল বা/এ, ঢাকা-১০০০
www.dpdt.gov.bd

Publication of Filed Patent Application
Publication No: 33 & Date: 21 June 2026

(11) Patent registration No and date , (21) Appl. No. BD-P-2024-330 (22) Filed: 07/11/2024
(23) Priority Data: United States of America, Number :63548063, Date : 10-11-2023.
(71) Applicant: KERRY GROUP SERVICES INTERNATIONAL LIMITED of Prince's Street Tralee, Co. Kerry V92 EH11, Nationality -Ireland
(72) Inventors: (0) HIGGINS, Niall of 53, The Drive, Bellingsfield Naas Kildare, Ireland Nationality -Ireland, (1) GEORIS, Jacques of Rue Basse Trixhes, 10 Couthuin B-4218, Belgium Nationality -Belgium, (2) LLAMAS-MOYA, Sara of Athgarrett, Eadestown Naas, Kildare W91 KC9E, Ireland Nationality -Spain
(74) Agent : Rana & Associates, Nipobon Asgar Garden, 462, Green Way, Flat No. A/2 (2nd Floor), Moghbazar, Dhaka-1217, Bangladesh
(51) INT. CL. : A23K 10/00
(54) Invention Title: Nucleases in animal feed
(57) Abstract The present invention relates to a method for improving an animal's growth performance and/or its nutrient utilization by administering an animal feed composition comprising a feed additive or a feed supplement having at least one nuclease. The nucleases in the feed composition hydrolyze in-situ the nucleic acids (DNA/RNA) present along the gastrointestinal tract (GIT) of an animal which in turn improves the release of nutritive oligonucleotides in the GIT of an animal. The improved release of nutritive oligonucleotides improves an animal's growth performance and/or its nutrient utilization, especially during stages with high metabolism and/or fast growth of the animals.



গণপ্রজাতন্ত্রী বাংলাদেশ সরকার
পেটেন্ট, শিল্প-নকশা ও ট্রেডমার্কস অধিদপ্তর
শিল্প মন্ত্রণালয়
৯১, মতিঝিল বা/এ, ঢাকা-১০০০
www.dpdt.gov.bd

**Publication of Filed Patent Application
Publication No: 33 & Date: 21 June 2026**

(11) Patent registration No and date , (21) Appl. No. BD-P-2024-331 (22) Filed: 10/11/2024	
(23) Priority Data: Russian Federation, Number :2023128962, Date : 08-11-2023.	
(71) Applicant: OOO «GEROPHARM» of Saint Petersburg, ul. Zvenigorodskaya, d. 9 191119, Nationality -Russian Federation	
(72) Inventors: (0) Petr Petrovich RODIONOV of Leningradskaya obl., Vsevolozhskiy r-n, d. Yukki, ul. Sadovaya, d. 20 188652, Russian Federation Nationality -Russian Federation, (1) Roman Vasilevich DRAI of Leningradskaya obl., Vsevolozhskiy r-n, d. Staraya, ul. Verhnyaya, d. 32, kv. 127 188688, Russian Federation Nationality -Russian Federation, (2) Maksim Andreevich MAGRUK of Saint Petersburg, pr. Metallistov, d. 117, k. 1, kv. 1452 195197, Russian Federation Nationality -Russian Federation, (3) Vitalii Feliksovich LATYPOV of g. Gatchina, Leningradskaya obl., pr. 25 Oktyabrya, d. 63, kv. 5 188300, Russian Federation Nationality -Russian Federation, (4) Evgeniia Aleksandrovna BUSLAEVA of Kirovskaya obl., g. Kirov, ul. Pugacheva, d. 33, kv. 62 610014, Russian Federation Nationality -Russian Federation, (5) Sergei Aleksandrovich ISHCHUK of g. Kostroma, ul. Krasnoarmeyskaya, d. 36, kv.25 156025, Russian Federation Nationality -Russian Federation, (6) Alina Nikolaevna AFANASEVA of Saint Petersburg, ul. Generala Kravchenko, d. 3, k. 3, str.1, kv. 431 198264, Russian Federation Nationality -Russian Federation, (7) Anastasiia Dmitrievna IASHTUBAEVA of Saint Petersburg, Petergofskoye sh., d. 78, k. 16, lit. A, kv. 34 198206, Russian Federation Nationality -Russian Federation	
(74) Agent : Rana & Associates, Nipobon Asgar Garden, 462, Green Way, Flat No. A/2 (2nd Floor), Moghbazar, Dhaka-1217, Bangladesh	
(51) INT. CL. : A61K 47/55	
(54) Invention Title: Fc FRAGMENT POLYPEPTIDE FOR PRODUCING THERAPEUTICALLY ACTIVE FUSION POLYPEPTIDES AND CONJUGATES	
(57) Abstract The invention relates to the field of biotechnology, namely to the immunoglobulin Fc fragment polypeptides, and can be used for medical applications. The disclosed immunoglobulin Fc-fragment polypeptides having high binding capacity for FcRn and low binding capacity for FcγRs can be used for the production of therapeutically active fusion polypeptides and conjugates.	<p>The diagram shows a circular plasmid map with a total size of 6811 bp. Key features include: a LacO binding site at position 114; an EcoRI site at position 114; a T7 gene leader at position 6730-6749; a SUMO tag; an RBS (Ribosome Binding Site); a LacI gene; a fragment bacterial origin; a SpeI site at position 1357; and a Prs66 site at position 2444-2489. Other elements like pBR322, pUC, and pUC19 are also indicated.</p>



গণপ্রজাতন্ত্রী বাংলাদেশ সরকার
পেটেন্ট, শিল্প-নকশা ও ট্রেডমার্কস অধিদপ্তর
শিল্প মন্ত্রণালয়
৯১, মতিঝিল বা/এ, ঢাকা-১০০০
www.dpdt.gov.bd

Publication of Filed Patent Application
Publication No: 33 & Date: 21 June 2026

(11) Patent registration No and date , (21) Appl. No. BD-P-2024-332 (22) Filed: 10/11/2024	
(23) Priority Data: Finland, Number :20245027, Date : 15-01-2024.	
(71) Applicant: Nokia Technologies Oy of Karakaari 7, 02610 Espoo, Nationality -Finland	
(72) Inventors: (1) Samuli Heikki TURTINEN of Salongintie 15, Ii, 91100, Finland Nationality -Finland, (2) Jussi-Pekka KOSKINEN of Kipinäkuja 10, Oulu, 90420, Finland Nationality -Finland, (3) Jakub Janusz BLUSZCZ of Macieja Rataja 29, Zabrze, 41-800, Poland Nationality -Poland	
(74) Agent : REMFRY & SON LIMITED, 56, NEW ESKATON ROAD 4TH FLOOR, DHAKA-1000, DHAKA, Bangladesh	
(51) INT. CL. : H03J 7/18	
(54) Invention Title: CELL BARRING BASED ON DEVICE CAPABILITY AT A FREQUENCY BAND	
(57) Abstract Various example embodiments relate to cell barring. A method may comprise: determining, by a device, a frequency band of a cell; receiving, by the device, an indication of a barring status of the cell, wherein the barring status is associated with a capability of the device; determining, by the device, the capability of the device at the frequency band of the cell; and determining, by the device, whether the cell is barred for the device based on the barring status and the capability of the device at the frequency band of the cell.	



গণপ্রজাতন্ত্রী বাংলাদেশ সরকার
পেটেন্ট, শিল্প-নকশা ও ট্রেডমার্কস অধিদপ্তর
শিল্প মন্ত্রণালয়
৯১, মতিঝিল বা/এ, ঢাকা-১০০০
www.dpdt.gov.bd

Publication of Filed Patent Application
Publication No: 33 & Date: 21 June 2026

(11) Patent registration No and date , (21) Appl. No. BD-P-2024-333 (22) Filed: 10/11/2024																																					
(23) Priority Data: India, Number :202341076811, Date : 10-11-2023. and India, Number :202441000286, Date : 02-01-2024. and India, Number :202441001631, Date : 09-01-2024. and India, Number :202441037320, Date : 11-05-2024. and United States of America, Number :63690894, Date : 05-09-2024.																																					
(71) Applicant: VRise Therapeutics, Inc. of Harvard Square,One Mifflin Pl, Ste 400, Cambridge, MA 02138, Nationality -United States of America																																					
(72) Inventors: (0) Prashant Kashinath Bhavar of C/O. VRise Therapeutics, Inc. of Harvard Square,One Mifflin Pl, Ste 400, Cambridge, MA 02138, United States of America Nationality -India, (1) Anuj Ramesh Kshirsagar of C/O. VeGen Therapeutics Pvt Ltd, of 7th Floor, South Wing, Krishe Sapphire, Madhapur Village, Hyderabad Telangana Pin code 500081, India Nationality -India, (2) Partha Pritam Sarma of C/O. VeGen Therapeutics Pvt Ltd, of 7th Floor, South Wing, Krishe Sapphire, Madhapur Village, Hyderabad Telangana Pin code 500081, India Nationality -India, (3) Appaji Baburao Mandhare of C/O. VeGen Therapeutics Pvt Ltd, of 7th Floor, South Wing, Krishe Sapphire, Madhapur Village, Hyderabad Telangana Pin code 500081, India Nationality -India, (4) Uday Kumar Surampudi of C/O. VRise Therapeutics, of Harvard Square,One Mifflin Pl, Ste 400, Cambridge, MA 02138, United States of America Nationality -India																																					
(74) Agent : Bepary & Bepary, 68-69 Concept Tower, Suite # 5-B (4th Floor), Green Road, Dhaka-1205, Bangladesh																																					
(51) INT. CL. : C07D 487/04																																					
(54) Invention Title: NOVEL MOLECULES AS INHIBITORS OF DNA DAMAGE REPAIR PATHWAY																																					
(57) Abstract The present application relates to novel compounds described herein, the method of preparing the same, its pharmaceutical composition and method for use thereof. In particular, the invention relates to compounds of formula (I) or their pharmaceutically acceptable salts thereof as inhibitors of ubiquitin-specific protease 1 (USP1) protein and useful in treatment, prevention and/or amelioration of diseases or disorders associated with ubiquitin-specific protease 1 (USP1) including Cancer.	Figure 1 <table border="1"><thead><tr><th>Days after the start of treatment</th><th>V1</th><th>C</th><th>A</th><th>V2</th><th>N</th></tr></thead><tbody><tr><td>0</td><td>100</td><td>100</td><td>100</td><td>100</td><td>100</td></tr><tr><td>7</td><td>150</td><td>120</td><td>110</td><td>100</td><td>100</td></tr><tr><td>14</td><td>220</td><td>180</td><td>150</td><td>120</td><td>100</td></tr><tr><td>21</td><td>300</td><td>250</td><td>200</td><td>150</td><td>70</td></tr><tr><td>28</td><td>420</td><td>320</td><td>280</td><td>250</td><td>50</td></tr></tbody></table>	Days after the start of treatment	V1	C	A	V2	N	0	100	100	100	100	100	7	150	120	110	100	100	14	220	180	150	120	100	21	300	250	200	150	70	28	420	320	280	250	50
Days after the start of treatment	V1	C	A	V2	N																																
0	100	100	100	100	100																																
7	150	120	110	100	100																																
14	220	180	150	120	100																																
21	300	250	200	150	70																																
28	420	320	280	250	50																																



গণপ্রজাতন্ত্রী বাংলাদেশ সরকার
 পেটেন্ট, শিল্প-নকশা ও ট্রেডমার্কস অধিদপ্তর
 শিল্প মন্ত্রণালয়
 ৯১, মতিঝিল বা/এ, ঢাকা-১০০০
www.dpdt.gov.bd

Publication of Filed Patent Application
Publication No: 33 & Date: 21 June 2026

(11) Patent registration No and date ,	
(21) Appl. No. BD-P-2024-334	
(22) Filed: 11/11/2024	
(23) Priority Data:	
N/A	
(71) Applicant: Bangladesh Council of Scientific and Industrial Research (BCSIR) of Dr. Qudrat-i-Khuda Road, Dhanmondi, Dhaka-1205, Nationality -Bangladesh	
(72) Inventors: (1) Dr. Kanika Mitra, Principal Scientific Officer of IFST, BCSIR, Dhanmondi, Dhaka-1205, Bangladesh Nationality -Bangladesh, (2) Dr. Md. Anwar Hossain, Principal Scientific Officer of Planning and Development Division, BCSIR, Dhanmondi, Dhaka-1205, Bangladesh Nationality -Bangladesh	
(51) INT. CL. : A23J 1/20	
(54) Invention Title: Optimization of the extraction of whey protein from milk	
(57) Abstract	
<p>Whey protein is a component of milk that is regarded as a beneficial nutrient. In order to produce protein hydrolysates with antioxidant and amino acid activities, "Whey protein concentrate (WPC)" was alcalase-acylated under the optimal condition in this study using "Response Surface Modeling (RSM)". To do this, a polynomial function was used to analyze the association between the variables and their individual and joint effects. FTIR analysis was done with ATR mode. An optimization technique was done using "Central Composite Design". Optimizing the ideal Alcalase-hydrolysis settings for producing whey protein was done using RSM of DPPH (AOAC method) and amino acid activity (HPLC method). The Expected R2 and the Adjusted R2 are within a tolerable range, i.e., the variability is less than 0.2. The signal-to-noise ratio is measured with acceptable precision. The model's ability to generate the predicted answers with a high degree of confidence was suggested by the overall desirability (D-value) of 1.00 with solution one. According to the findings, the ideal conditions were reached at pH= 6.14, hydrolysis time= 4.00 hours and temperature= 44.280C to produce the highest yields (8.55%), highest levels of protein (9.46%), highest levels of α, α-diphenyl-β-picrylhydrazyl (DPPH) inhibition activity (45.96%) and highest levels of amino acids (7.00%). The regression model's suitability was confirmed by the well-fitted analysis data. The present study showed that WPC could produce bio-functional hydrolysates with antioxidant and amino acid activity. This finding supports the use of WPC hydrolysate as a new natural ingredient for the production of functional food products.</p>	<p>1: Biological properties of the whey protein derivatives</p>



গণপ্রজাতন্ত্রী বাংলাদেশ সরকার
পেটেন্ট, শিল্প-নকশা ও ট্রেডমার্কস অধিদপ্তর
শিল্প মন্ত্রণালয়
৯১, মতিঝিল বা/এ, ঢাকা-১০০০
www.dpdt.gov.bd

Publication of Filed Patent Application
Publication No: 33 & Date: 21 June 2026

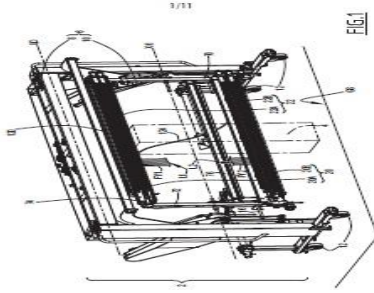
(11) Patent registration No and date , (21) Appl. No. BD-P-2024-335 (22) Filed: 12/11/2024	
(23) Priority Data: European Patent Office (EPO), Number :232094730, Date : 13-11-2023.	
(71) Applicant: STÄUBLI SARGANS AG of Grossfeldstrasse 71 SARGANS, 7320, Nationality -Switzerland	
(72) Inventors: (1) FONTANA Gion of Gürtelstrasse 70, CHUR, 7000, Switzerland Nationality -Switzerland, (2) GAUER Thomas of Schlossgasse 3, SARGANS, 7320, Switzerland Nationality -Switzerland	
(74) Agent : REMFRY & SON LIMITED, 56, NEW ESKATON ROAD 4TH FLOOR, DHAKA-1000, DHAKA, Bangladesh	
(51) INT. CL. : B41F 13/03	
(54) Invention Title: Clamping device for a drawing-in machine, drawing-in machine including such a clamping device and corresponding drawing-in method	
(57) Abstract This clamping device comprises a frame structure (10) movable along a longitudinal direction with respect to a drawing-in unit of a drawing-in machine, a first clamping rail (20A) and a second clamping rail for clamping a first yarn layer (L1), secured with the frame structure (10) along the longitudinal direction, a third clamping rail (22A) and a fourth clamping rail for clamping a second yarn layer (L2), connected to the frame structure (10) through a slide link (88) and movable with respect to the frame structure (10) along the longitudinal direction (LD). A switch element (100) longitudinally secured to the third clamping rail (22A) is movable between a first position, where it longitudinally secures the third clamping rail to the first clamping rail (20A), and a second position, where it allows a relative longitudinal movement of the third clamping rail relative to the first clamping rail and does not cooperate neither with the frame structure nor with the first and second clamping rails.	



গণপ্রজাতন্ত্রী বাংলাদেশ সরকার
পেটেন্ট, শিল্প-নকশা ও ট্রেডমার্কস অধিদপ্তর
শিল্প মন্ত্রণালয়
৯১, মতিঝিল বা/এ, ঢাকা-১০০০
www.dpdt.gov.bd

Publication of Filed Patent Application
Publication No: 33 & Date: 21 June 2026

(11) Patent registration No and date , (21) Appl. No. BD-P-2024-336 (22) Filed: 12/11/2024	
(23) Priority Data: Japan, Number :2024000827, Date : 15-01-2024.	
(71) Applicant: YKK CORPORATION of 1, Kanda izumi-cho, Chiyoda-ku, Tokyo 101-8642, Nationality -Japan	
(72) Inventors: (1) YOSUKE MATSUKI of c/o YKK CORPORATION KUROBE, 200, Yoshida, Kurobe-shi, Toyama, 938-8601, Japan Nationality -Japan, (2) SEIJI UCHIYAMA of c/o YKK CORPORATION KUROBE, 200, Yoshida, Kurobe-shi, Toyama, 938-8601, Japan Nationality -Japan, (3) KOSUKE NAKANO of c/o YKK CORPORATION KUROBE, 200, Yoshida, Kurobe-shi, Toyama, 938-8601, Japan Nationality -Japan, (4) MIKA ARAI of c/o YKK CORPORATION KUROBE, 200, Yoshida, Kurobe-shi, Toyama, 938-8601, Japan Nationality -Japan	
(74) Agent : REMFRY & SON LIMITED, 56, NEW ESKATON ROAD 4TH FLOOR, DHAKA-1000, DHAKA, Bangladesh	
(51) INT. CL. : B23B 39/18	
(54) Invention Title: WORK SETTING DEVICE	
(57) Abstract A work setting device includes:a work;a work holding portion having a plurality of mounting portions;an image data acquiring portion;a conveyance mechanism; and a controller. The controller is configured to:determine whether the work is attachable to the mounting portion by comparing an acquired image data of the mounting portion acquired from the image data acquiring portion with previously stored master image data,cause the work to be attached to the mounting portion when it is determined that the work is attachable to the mounting portion, andcause the work to relatively move toward the mounting portion next to the mounting portion when it is determined that the work is not attachable to the mounting portion, or after the work is attached to the mounting portion.	



গণপ্রজাতন্ত্রী বাংলাদেশ সরকার
পেটেন্ট, শিল্প-নকশা ও ট্রেডমার্কস অধিদপ্তর
শিল্প মন্ত্রণালয়
৯১, মতিঝিল বা/এ, ঢাকা-১০০০
www.dpdt.gov.bd

Publication of Filed Patent Application
Publication No: 33 & Date: 21 June 2026

(11) Patent registration No and date , (21) Appl. No. BD-P-2024-337 (22) Filed: 14/11/2024																									
(23) Priority Data: N/A																									
(71) Applicant: Engr. Md. Ahsan Habib of Jashore University of Science and Technology, Jashore 7408, Nationality - Bangladesh																									
(72) Inventors: (1) Dr. Md. Zaved Hossain Khan, Professor of Dept. of Chemical Engineering, Jashore University of Science and Technology, Jashore 7408 , Bangladesh Nationality -Bangladesh																									
(51) INT. CL. : A24F 13/06																									
(54) Invention Title: Formulation of Nano paint for fire retardant and smoke suppressant																									
(57) Abstract The invention relates to a nano fire-retardant paint that provides enhanced fire resistance and smoke suppression through the incorporation of nano-sized particles. The paint composition includes nano-encapsulated fire-retardant particles, such as nano-silica, nano-phosphates, or nano-aluminum hydroxide, which release fire-retardant gases upon exposure to high temperatures, reducing the spread of fire. Additionally, the formulation contains nano-intumescent agents (e.g., ammonium polyphosphate) that expand under heat to form a protective char layer, insulating the substrate from flames. Nano smoke suppressant particles, such as nano-zinc borate or nano-magnesium hydroxide, reduce smoke density and toxicity during combustion. The paint is designed to be applied in a thin, durable layer that offers long-term fire protection, improving safety in residential, commercial, and industrial applications. This innovative composition is cost-effective, eco-friendly, and suitable for a variety of substrates including wood, metal, and concrete.																									
Figure 1: Nano Fire-Retardant Paint formulation ingredients																									
	<table border="1"> <thead> <tr> <th>Ingredient</th> <th>Percentage (%)</th> <th>Function</th> </tr> </thead> <tbody> <tr> <td>Polymeric Binder</td> <td>12-20%</td> <td>Acts as a film-forming agent, providing adhesion, flexibility, and durability to the paint film. Examples: Acrylic, Epoxy, or Silicone resin.</td> </tr> <tr> <td>Nano-Encapsulated Retardant Particles</td> <td>5-15%</td> <td>Provides fire resistance by releasing fire-retardant gases upon exposure to heat. Examples: Nano-silica, Nano-aluminum hydroxide, Nano-phosphates.</td> </tr> <tr> <td>Intumescent Agents</td> <td>10-20%</td> <td>Expands under heat to form an insulating char layer, slowing down fire spread. Examples: Ammonium polyphosphate, Melamine, or expandable graphite.</td> </tr> <tr> <td>Nano Smoke Suppressant Particles</td> <td>1-10%</td> <td>Reduces smoke density and toxicity during combustion. Examples: Nano zinc borate, Nano magnesium hydroxide.</td> </tr> <tr> <td>Fillers</td> <td>1-5%</td> <td>Adds bulk, reduces cost, and enhances structural stability. Examples: Calcium carbonate, Titanium dioxide, or clay.</td> </tr> <tr> <td>Pigments</td> <td>1-5%</td> <td>Provides color, opacity, and additional UV stability. Example: Titanium dioxide for white or other colors as per requirement.</td> </tr> <tr> <td>Dispersants/Stabilizers</td> <td>0.5-3%</td> <td>Ensures uniform distribution of nano particles and prevents agglomeration. Example: Polyacrylate or lecithin.</td> </tr> </tbody> </table>	Ingredient	Percentage (%)	Function	Polymeric Binder	12-20%	Acts as a film-forming agent, providing adhesion, flexibility, and durability to the paint film. Examples: Acrylic, Epoxy, or Silicone resin.	Nano-Encapsulated Retardant Particles	5-15%	Provides fire resistance by releasing fire-retardant gases upon exposure to heat. Examples: Nano-silica, Nano-aluminum hydroxide, Nano-phosphates.	Intumescent Agents	10-20%	Expands under heat to form an insulating char layer, slowing down fire spread. Examples: Ammonium polyphosphate, Melamine, or expandable graphite.	Nano Smoke Suppressant Particles	1-10%	Reduces smoke density and toxicity during combustion. Examples: Nano zinc borate, Nano magnesium hydroxide.	Fillers	1-5%	Adds bulk, reduces cost, and enhances structural stability. Examples: Calcium carbonate, Titanium dioxide, or clay.	Pigments	1-5%	Provides color, opacity, and additional UV stability. Example: Titanium dioxide for white or other colors as per requirement.	Dispersants/Stabilizers	0.5-3%	Ensures uniform distribution of nano particles and prevents agglomeration. Example: Polyacrylate or lecithin.
Ingredient	Percentage (%)	Function																							
Polymeric Binder	12-20%	Acts as a film-forming agent, providing adhesion, flexibility, and durability to the paint film. Examples: Acrylic, Epoxy, or Silicone resin.																							
Nano-Encapsulated Retardant Particles	5-15%	Provides fire resistance by releasing fire-retardant gases upon exposure to heat. Examples: Nano-silica, Nano-aluminum hydroxide, Nano-phosphates.																							
Intumescent Agents	10-20%	Expands under heat to form an insulating char layer, slowing down fire spread. Examples: Ammonium polyphosphate, Melamine, or expandable graphite.																							
Nano Smoke Suppressant Particles	1-10%	Reduces smoke density and toxicity during combustion. Examples: Nano zinc borate, Nano magnesium hydroxide.																							
Fillers	1-5%	Adds bulk, reduces cost, and enhances structural stability. Examples: Calcium carbonate, Titanium dioxide, or clay.																							
Pigments	1-5%	Provides color, opacity, and additional UV stability. Example: Titanium dioxide for white or other colors as per requirement.																							
Dispersants/Stabilizers	0.5-3%	Ensures uniform distribution of nano particles and prevents agglomeration. Example: Polyacrylate or lecithin.																							



গণপ্রজাতন্ত্রী বাংলাদেশ সরকার
পেটেন্ট, শিল্প-নকশা ও ট্রেডমার্কস অধিদপ্তর
শিল্প মন্ত্রণালয়
৯১, মতিঝিল বা/এ, ঢাকা-১০০০
www.dpdt.gov.bd

Publication of Filed Patent Application
Publication No: 33 & Date: 21 June 2026

(11) Patent registration No and date ,																																											
(21) Appl. No. BD-P-2024-338																																											
(22) Filed: 14/11/2024																																											
(23) Priority Data:																																											
N/A																																											
(71) Applicant: Engr. Md. Ahsan Habib of Jashore University of Science and Technology, Jashore 7408, Nationality - Bangladesh																																											
(72) Inventors: (1) Dr. Md. Zaved Hossain Khan, Professor of Dept. of Chemical Engineering, Jashore University of Science and Technology, Jashore 7408 , Bangladesh Nationality -Bangladesh																																											
(51) INT. CL. : A61Q 19/02																																											
(54) Invention Title: Nano Skin Whitening Soap Formulation																																											
(57) Abstract																																											
<p>This invention relates to a nano whitening soap formulation that combines skin-brightening agents and moisturizers encapsulated in nano-sized particles to enhance efficacy, penetration, and stability. The soap utilizes nanotechnology to deliver active ingredients such as kojic acid, niacinamide, and Vitamin C at a nanoscale, allowing for deeper skin penetration and controlled release, which results in prolonged brightening effects and minimized skin irritation. The nano whitening soap also includes nano-encapsulated moisturizing agents, such as hyaluronic acid and glycerin, to retain skin hydration and prevent dryness. The soap base is formulated with a combination of saponified natural oils to create a gentle and effective cleansing product. This innovative approach ensures improved absorption and distribution of active ingredients, providing users with a smoother, brighter, and more hydrated skin appearance.</p>																																											
<p>Figure 1: Nano Whitening Soap Formulation</p> <table border="1"> <thead> <tr> <th>Ingredients</th> <th>Function</th> <th>Percentage (%)</th> </tr> </thead> <tbody> <tr> <td>Soap Base (Sodium Palmate, Sodium Palm Kernelate, etc.)</td> <td>Cleansing, lather</td> <td>60%</td> </tr> <tr> <td>Nano-Encapsulated Kojic Acid</td> <td>Skin brightening, reduces pigmentation</td> <td>2%</td> </tr> <tr> <td>Nano-Encapsulated Vitamin C (Ascorbic Acid)</td> <td>Antioxidant, brightens skin</td> <td>1%</td> </tr> <tr> <td>Nano-Encapsulated Niacinamide (Vitamin B3)</td> <td>Reduces spots, evens skin tone</td> <td>2%</td> </tr> <tr> <td>Nano-Encapsulated Glycerin</td> <td>Antioxidant, hydrates and soothes skin</td> <td>1%</td> </tr> <tr> <td>Glycerin</td> <td>Moisturizes, prevents dryness</td> <td>5%</td> </tr> <tr> <td>Aloe Vera Extract</td> <td>Soothes and moisturizes skin</td> <td>3%</td> </tr> <tr> <td>Cocconut Oil</td> <td>Moisturizes, adds lather</td> <td>3%</td> </tr> <tr> <td>Olive Oil</td> <td>Moisturizes, soothes skin</td> <td>3%</td> </tr> <tr> <td>Shea Butter</td> <td>Emollient, softens skin</td> <td>3%</td> </tr> <tr> <td>Green Tea Extract</td> <td>Antioxidant, reduces inflammation</td> <td>1%</td> </tr> <tr> <td>Fragrance (optional)</td> <td>Adds pleasant scent</td> <td>0.5%</td> </tr> <tr> <td>Preservative (e.g., Phenoxyethanol)</td> <td>Prevents microbial growth</td> <td>0.5%</td> </tr> </tbody> </table>		Ingredients	Function	Percentage (%)	Soap Base (Sodium Palmate, Sodium Palm Kernelate, etc.)	Cleansing, lather	60%	Nano-Encapsulated Kojic Acid	Skin brightening, reduces pigmentation	2%	Nano-Encapsulated Vitamin C (Ascorbic Acid)	Antioxidant, brightens skin	1%	Nano-Encapsulated Niacinamide (Vitamin B3)	Reduces spots, evens skin tone	2%	Nano-Encapsulated Glycerin	Antioxidant, hydrates and soothes skin	1%	Glycerin	Moisturizes, prevents dryness	5%	Aloe Vera Extract	Soothes and moisturizes skin	3%	Cocconut Oil	Moisturizes, adds lather	3%	Olive Oil	Moisturizes, soothes skin	3%	Shea Butter	Emollient, softens skin	3%	Green Tea Extract	Antioxidant, reduces inflammation	1%	Fragrance (optional)	Adds pleasant scent	0.5%	Preservative (e.g., Phenoxyethanol)	Prevents microbial growth	0.5%
Ingredients	Function	Percentage (%)																																									
Soap Base (Sodium Palmate, Sodium Palm Kernelate, etc.)	Cleansing, lather	60%																																									
Nano-Encapsulated Kojic Acid	Skin brightening, reduces pigmentation	2%																																									
Nano-Encapsulated Vitamin C (Ascorbic Acid)	Antioxidant, brightens skin	1%																																									
Nano-Encapsulated Niacinamide (Vitamin B3)	Reduces spots, evens skin tone	2%																																									
Nano-Encapsulated Glycerin	Antioxidant, hydrates and soothes skin	1%																																									
Glycerin	Moisturizes, prevents dryness	5%																																									
Aloe Vera Extract	Soothes and moisturizes skin	3%																																									
Cocconut Oil	Moisturizes, adds lather	3%																																									
Olive Oil	Moisturizes, soothes skin	3%																																									
Shea Butter	Emollient, softens skin	3%																																									
Green Tea Extract	Antioxidant, reduces inflammation	1%																																									
Fragrance (optional)	Adds pleasant scent	0.5%																																									
Preservative (e.g., Phenoxyethanol)	Prevents microbial growth	0.5%																																									



গণপ্রজাতন্ত্রী বাংলাদেশ সরকার
পেটেন্ট, শিল্প-নকশা ও ট্রেডমার্কস অধিদপ্তর
শিল্প মন্ত্রণালয়
৯১, মতিঝিল বা/এ, ঢাকা-১০০০
www.dpdt.gov.bd

Publication of Filed Patent Application
Publication No: 33 & Date: 21 June 2026

(11) Patent registration No and date ,																																																																			
(21) Appl. No. BD-P-2024-339																																																																			
(22) Filed: 14/11/2024																																																																			
(23) Priority Data:																																																																			
N/A																																																																			
(71) Applicant: Engr. Md. Ahsan Habib of Jashore University of Science and Technology, Jashore 7408, Nationality - Bangladesh																																																																			
(72) Inventors: (1) Dr. Md. Zaved Hossain Khan, Professor of Dept. of Chemical Engineering, Jashore University of Science and Technology, Jashore 7408 , Bangladesh Nationality -Bangladesh																																																																			
(51) INT. CL. : A61Q 19/00																																																																			
(54) Invention Title: Formulation of Nano Body Lotion																																																																			
(57) Abstract																																																																			
<p>The present invention relates to a Nano Body Lotion that utilizes nanoparticles to deliver active ingredients more effectively through the skin. The formulation leverages nanotechnology to enhance the absorption and bioavailability of beneficial compounds, providing improved hydration, nourishment, and protection for the skin. This nano-based delivery system allows for deeper penetration, prolonged effects, and a more efficient release of active ingredients compared to conventional lotions.</p>																																																																			
Figure 1: Nano body lotion formulation																																																																			
<table border="1"> <thead> <tr> <th>Ingredient</th> <th>Percentage (%)</th> <th>Function</th> </tr> </thead> <tbody> <tr> <td>Water</td> <td>50-70%</td> <td>Base Solvent</td> </tr> <tr> <td>Emollients</td> <td>5-20%</td> <td>Moisturizes and softens skin</td> </tr> <tr> <td>Jajoba Oil</td> <td>1-5%</td> <td>Provides hydration and nourishment</td> </tr> <tr> <td>Argan Oil</td> <td>1-5%</td> <td>Adds elasticity and smoothness</td> </tr> <tr> <td>Humectants</td> <td>5-10%</td> <td>Attracts moisture to the skin</td> </tr> <tr> <td>Glycerin</td> <td>3-7%</td> <td>Hydrates and retains moisture</td> </tr> <tr> <td>Hyaluronic Acid</td> <td>0.1-0.5%</td> <td>Deep moisturization</td> </tr> <tr> <td>Nanoparticles</td> <td>1-3%</td> <td>Nano delivery of active ingredients</td> </tr> <tr> <td>Lipid-Based Polymeric</td> <td>1-3%</td> <td>Enhances absorption and efficacy</td> </tr> <tr> <td>Active Ingredients</td> <td>0.5-5%</td> <td>Provides targeted skincare benefits</td> </tr> <tr> <td>Vitamin E</td> <td>0.1-0.5%</td> <td>Antioxidant</td> </tr> <tr> <td>Vitamin C</td> <td>0.1-0.5%</td> <td>Brightening and anti-aging</td> </tr> <tr> <td>Green Tea Extract</td> <td>0.1-0.3%</td> <td>Antioxidant and soothing</td> </tr> <tr> <td>Emulsifiers</td> <td>2-5%</td> <td>Stabilizes the lotion</td> </tr> <tr> <td>Cetyl Alcohol</td> <td>1-3%</td> <td>Thickener and stabilizer</td> </tr> <tr> <td>Polyisobutyl 20 or 60</td> <td>0.5-1.5%</td> <td>Helps mix oil and water phases</td> </tr> <tr> <td>Preservatives</td> <td>0.5-1%</td> <td>Prevents microbial growth</td> </tr> <tr> <td>Phenoxyethanol</td> <td>0.5-1%</td> <td>Broad-spectrum preservative</td> </tr> <tr> <td>Fragrance</td> <td>0.1%</td> <td>Adds scent (optional)</td> </tr> <tr> <td>Thickening Agents</td> <td>0.1-1%</td> <td>Improves lotion texture</td> </tr> <tr> <td>Xanthan Gum</td> <td>0.1-0.3%</td> <td>Increases viscosity</td> </tr> </tbody> </table>		Ingredient	Percentage (%)	Function	Water	50-70%	Base Solvent	Emollients	5-20%	Moisturizes and softens skin	Jajoba Oil	1-5%	Provides hydration and nourishment	Argan Oil	1-5%	Adds elasticity and smoothness	Humectants	5-10%	Attracts moisture to the skin	Glycerin	3-7%	Hydrates and retains moisture	Hyaluronic Acid	0.1-0.5%	Deep moisturization	Nanoparticles	1-3%	Nano delivery of active ingredients	Lipid-Based Polymeric	1-3%	Enhances absorption and efficacy	Active Ingredients	0.5-5%	Provides targeted skincare benefits	Vitamin E	0.1-0.5%	Antioxidant	Vitamin C	0.1-0.5%	Brightening and anti-aging	Green Tea Extract	0.1-0.3%	Antioxidant and soothing	Emulsifiers	2-5%	Stabilizes the lotion	Cetyl Alcohol	1-3%	Thickener and stabilizer	Polyisobutyl 20 or 60	0.5-1.5%	Helps mix oil and water phases	Preservatives	0.5-1%	Prevents microbial growth	Phenoxyethanol	0.5-1%	Broad-spectrum preservative	Fragrance	0.1%	Adds scent (optional)	Thickening Agents	0.1-1%	Improves lotion texture	Xanthan Gum	0.1-0.3%	Increases viscosity
Ingredient	Percentage (%)	Function																																																																	
Water	50-70%	Base Solvent																																																																	
Emollients	5-20%	Moisturizes and softens skin																																																																	
Jajoba Oil	1-5%	Provides hydration and nourishment																																																																	
Argan Oil	1-5%	Adds elasticity and smoothness																																																																	
Humectants	5-10%	Attracts moisture to the skin																																																																	
Glycerin	3-7%	Hydrates and retains moisture																																																																	
Hyaluronic Acid	0.1-0.5%	Deep moisturization																																																																	
Nanoparticles	1-3%	Nano delivery of active ingredients																																																																	
Lipid-Based Polymeric	1-3%	Enhances absorption and efficacy																																																																	
Active Ingredients	0.5-5%	Provides targeted skincare benefits																																																																	
Vitamin E	0.1-0.5%	Antioxidant																																																																	
Vitamin C	0.1-0.5%	Brightening and anti-aging																																																																	
Green Tea Extract	0.1-0.3%	Antioxidant and soothing																																																																	
Emulsifiers	2-5%	Stabilizes the lotion																																																																	
Cetyl Alcohol	1-3%	Thickener and stabilizer																																																																	
Polyisobutyl 20 or 60	0.5-1.5%	Helps mix oil and water phases																																																																	
Preservatives	0.5-1%	Prevents microbial growth																																																																	
Phenoxyethanol	0.5-1%	Broad-spectrum preservative																																																																	
Fragrance	0.1%	Adds scent (optional)																																																																	
Thickening Agents	0.1-1%	Improves lotion texture																																																																	
Xanthan Gum	0.1-0.3%	Increases viscosity																																																																	



গণপ্রজাতন্ত্রী বাংলাদেশ সরকার
পেটেন্ট, শিল্প-নকশা ও ট্রেডমার্কস অধিদপ্তর
শিল্প মন্ত্রণালয়
৯১, মতিঝিল বা/এ, ঢাকা-১০০০
www.dpdt.gov.bd

Publication of Filed Patent Application
Publication No: 33 & Date: 21 June 2026

(11) Patent registration No and date ,																																								
(21) Appl. No. BD-P-2024-340																																								
(22) Filed: 14/11/2024																																								
(23) Priority Data:																																								
N/A																																								
(71) Applicant: Engr. Md. Ahsan Habib of Jashore University of Science and Technology, Jashore 7408, Nationality - Bangladesh																																								
(72) Inventors: (1) Dr. Md. Zaved Hossain Khan, Professor of Dept. of Chemical Engineering, Jashore University of Science and Technology, Jashore 7408 , Bangladesh Nationality -Bangladesh																																								
(51) INT. CL. : A61Q 19/08																																								
(54) Invention Title: Formulation of Nano Face Serum with Enhanced Skin Brightening																																								
(57) Abstract																																								
<p>This invention relates to a nano-enhanced face serum formulation that improves skin absorption, hydration, and overall skin appearance by utilizing nano-encapsulated active ingredients. The serum contains nano-sized particles of key active compounds such as hyaluronic acid, Vitamin C, retinol, and niacinamide, each encapsulated within biodegradable carriers. This nano-encapsulation facilitates deep skin penetration, controlled release, and enhanced stability of active ingredients, providing prolonged hydration, brightening, and anti-aging effects. The formulation includes a gentle, stabilizing serum base to support skin health while reducing irritation often associated with potent actives. The innovative approach ensures improved effectiveness and longevity, making this serum suitable for daily skincare routines aimed at achieving a brighter, hydrated, and youthful complexion.</p>																																								
<p style="text-align: center;">Figure 1: Nano Face Serum Formulation</p> <table border="1"> <thead> <tr> <th>Ingredient</th> <th>Function</th> <th>Percentage (%)</th> </tr> </thead> <tbody> <tr> <td>Aqua (Water)</td> <td>Solvent, hydration</td> <td>50%</td> </tr> <tr> <td>Nano-Encapsulated Hyaluronic Acid</td> <td>Deep hydration, plumps skin</td> <td>2%</td> </tr> <tr> <td>Nano-Encapsulated Vitamin C</td> <td>Antioxidant, brightens skin</td> <td>2%</td> </tr> <tr> <td>Nano-Encapsulated Retinol</td> <td>Anti-aging, promotes cell turnover</td> <td>0.2%</td> </tr> <tr> <td>Nano-Encapsulated Niacinamide (Vitamin B3)</td> <td>Brightens, improves elasticity</td> <td>2%</td> </tr> <tr> <td>Nano-Encapsulated Peptides</td> <td>Collagen booster</td> <td>1%</td> </tr> <tr> <td>Glycerin</td> <td>Humectant, retains moisture</td> <td>5%</td> </tr> <tr> <td>Sodium PCA</td> <td>Humectant, binds moisture to skin</td> <td>3%</td> </tr> <tr> <td>Panthenol (Pro-Vitamin B5)</td> <td>Moisturizer, soothes skin</td> <td>1%</td> </tr> <tr> <td> Aloe Vera Extract</td> <td>Soothing, hydrates</td> <td>10%</td> </tr> <tr> <td>Emulsifier (e.g., Lecithin)</td> <td>Stabilizes nano-particles in serum</td> <td>2%</td> </tr> <tr> <td>Vitamin E (Tocopherol)</td> <td>Antioxidant, protects nano-actives</td> <td>0.2%</td> </tr> </tbody> </table>		Ingredient	Function	Percentage (%)	Aqua (Water)	Solvent, hydration	50%	Nano-Encapsulated Hyaluronic Acid	Deep hydration, plumps skin	2%	Nano-Encapsulated Vitamin C	Antioxidant, brightens skin	2%	Nano-Encapsulated Retinol	Anti-aging, promotes cell turnover	0.2%	Nano-Encapsulated Niacinamide (Vitamin B3)	Brightens, improves elasticity	2%	Nano-Encapsulated Peptides	Collagen booster	1%	Glycerin	Humectant, retains moisture	5%	Sodium PCA	Humectant, binds moisture to skin	3%	Panthenol (Pro-Vitamin B5)	Moisturizer, soothes skin	1%	Aloe Vera Extract	Soothing, hydrates	10%	Emulsifier (e.g., Lecithin)	Stabilizes nano-particles in serum	2%	Vitamin E (Tocopherol)	Antioxidant, protects nano-actives	0.2%
Ingredient	Function	Percentage (%)																																						
Aqua (Water)	Solvent, hydration	50%																																						
Nano-Encapsulated Hyaluronic Acid	Deep hydration, plumps skin	2%																																						
Nano-Encapsulated Vitamin C	Antioxidant, brightens skin	2%																																						
Nano-Encapsulated Retinol	Anti-aging, promotes cell turnover	0.2%																																						
Nano-Encapsulated Niacinamide (Vitamin B3)	Brightens, improves elasticity	2%																																						
Nano-Encapsulated Peptides	Collagen booster	1%																																						
Glycerin	Humectant, retains moisture	5%																																						
Sodium PCA	Humectant, binds moisture to skin	3%																																						
Panthenol (Pro-Vitamin B5)	Moisturizer, soothes skin	1%																																						
Aloe Vera Extract	Soothing, hydrates	10%																																						
Emulsifier (e.g., Lecithin)	Stabilizes nano-particles in serum	2%																																						
Vitamin E (Tocopherol)	Antioxidant, protects nano-actives	0.2%																																						



গণপ্রজাতন্ত্রী বাংলাদেশ সরকার
পেটেন্ট, শিল্প-নকশা ও ট্রেডমার্কস অধিদপ্তর
শিল্প মন্ত্রণালয়
৯১, মতিঝিল বা/এ, ঢাকা-১০০০
www.dpdt.gov.bd

Publication of Filed Patent Application
Publication No: 33 & Date: 21 June 2026

(11) Patent registration No and date , (21) Appl. No. BD-P-2024-341 (22) Filed: 14/11/2024																																																					
(23) Priority Data: N/A																																																					
(71) Applicant: Engr. Md. Ahsan Habib of Jashore University of Science and Technology, Jashore 7408, Nationality - Bangladesh																																																					
(72) Inventors: (1) Dr. Md. Zaved Hossain Khan, Professor of Dept. of Chemical Engineering, Jashore University of Science and Technology, Jashore 7408 , Bangladesh Nationality -Bangladesh																																																					
(51) INT. CL. : A61Q 7/00																																																					
(54) Invention Title: Formulation of Nano-Encapsulated Hair Nutrient Serum																																																					
(57) Abstract The invention discloses a nano-encapsulated hair nutrient serum formulated for deep scalp and follicle penetration, delivering essential vitamins, minerals, and botanical extracts through a nanoscale delivery system. This serum enhances absorption, supports hair growth, and improves hair resilience, providing an effective solution for hair loss prevention and scalp health.																																																					
Figure 1. Hair Nutrients Serum Formulation Table																																																					
<table border="1"><thead><tr><th>Ingredient</th><th>Function</th><th>Percentage (%)</th></tr></thead><tbody><tr><td>Water (Aqua)</td><td>Solvent Base</td><td>40.00</td></tr><tr><td>Glycerin</td><td>Humectant, Moisturizer</td><td>10.00</td></tr><tr><td>Panthenol (Pro-Vitamin B5)</td><td>Conditioning, Strengthening</td><td>2.00</td></tr><tr><td>Biotin</td><td>Hair Growth, Strengthening</td><td>0.50</td></tr><tr><td>Niacinamide (Vitamin B3)</td><td>Strengthens, Reduces Breakage</td><td>2.00</td></tr><tr><td>Hyaluronic Acid</td><td>Hydration</td><td>1.00</td></tr><tr><td>Keratin Peptides</td><td>Strengthens Hair Structure</td><td>2.00</td></tr><tr><td>Argan Oil</td><td>Nourishing, Moisturizing</td><td>2.00</td></tr><tr><td>Vitamin E</td><td>Antioxidant, Hair Health</td><td>1.00</td></tr><tr><td>Aloe Vera Extract</td><td>Soothing, Moisturizing</td><td>10.00</td></tr><tr><td>BHK Amino Acids</td><td>Softening, Conditioning</td><td>2.00</td></tr><tr><td>Hydrolyzed Wheat Protein</td><td>Strengthens, Repairs</td><td>2.00</td></tr><tr><td>Caffeine</td><td>Stimulates Follicles</td><td>1.00</td></tr><tr><td>Essential Oils</td><td>Fragrance, Scalp Health</td><td>1.00</td></tr><tr><td>Phenoxyethanol</td><td>Preservative</td><td>0.75</td></tr><tr><td>EdoHexylglycerin</td><td>Preservative</td><td>0.25</td></tr></tbody></table>	Ingredient	Function	Percentage (%)	Water (Aqua)	Solvent Base	40.00	Glycerin	Humectant, Moisturizer	10.00	Panthenol (Pro-Vitamin B5)	Conditioning, Strengthening	2.00	Biotin	Hair Growth, Strengthening	0.50	Niacinamide (Vitamin B3)	Strengthens, Reduces Breakage	2.00	Hyaluronic Acid	Hydration	1.00	Keratin Peptides	Strengthens Hair Structure	2.00	Argan Oil	Nourishing, Moisturizing	2.00	Vitamin E	Antioxidant, Hair Health	1.00	Aloe Vera Extract	Soothing, Moisturizing	10.00	BHK Amino Acids	Softening, Conditioning	2.00	Hydrolyzed Wheat Protein	Strengthens, Repairs	2.00	Caffeine	Stimulates Follicles	1.00	Essential Oils	Fragrance, Scalp Health	1.00	Phenoxyethanol	Preservative	0.75	EdoHexylglycerin	Preservative	0.25		
Ingredient	Function	Percentage (%)																																																			
Water (Aqua)	Solvent Base	40.00																																																			
Glycerin	Humectant, Moisturizer	10.00																																																			
Panthenol (Pro-Vitamin B5)	Conditioning, Strengthening	2.00																																																			
Biotin	Hair Growth, Strengthening	0.50																																																			
Niacinamide (Vitamin B3)	Strengthens, Reduces Breakage	2.00																																																			
Hyaluronic Acid	Hydration	1.00																																																			
Keratin Peptides	Strengthens Hair Structure	2.00																																																			
Argan Oil	Nourishing, Moisturizing	2.00																																																			
Vitamin E	Antioxidant, Hair Health	1.00																																																			
Aloe Vera Extract	Soothing, Moisturizing	10.00																																																			
BHK Amino Acids	Softening, Conditioning	2.00																																																			
Hydrolyzed Wheat Protein	Strengthens, Repairs	2.00																																																			
Caffeine	Stimulates Follicles	1.00																																																			
Essential Oils	Fragrance, Scalp Health	1.00																																																			
Phenoxyethanol	Preservative	0.75																																																			
EdoHexylglycerin	Preservative	0.25																																																			



গণপ্রজাতন্ত্রী বাংলাদেশ সরকার
পেটেন্ট, শিল্প-নকশা ও ট্রেডমার্কস অধিদপ্তর
শিল্প মন্ত্রণালয়
৯১, মতিঝিল বা/এ, ঢাকা-১০০০
www.dpdt.gov.bd

Publication of Filed Patent Application
Publication No: 33 & Date: 21 June 2026

(11) Patent registration No and date , (21) Appl. No. BD-P-2024-342 (22) Filed: 14/11/2024																																												
(23) Priority Data: N/A																																												
(71) Applicant: Engr. Md. Ahsan Habib of Jashore University of Science and Technology, Jashore 7408, Nationality - Bangladesh																																												
(72) Inventors: (0) Dr. Md. Zaved Hossain Khan, Professor of Dept. of Chemical Engineering, Jashore University of Science and Technology, Jashore 7408 , Bangladesh Nationality -Bangladesh																																												
(51) INT. CL. : A61K 8/60																																												
(54) Invention Title: Formulation of Nano Whitening Cream for Skin Brightening																																												
(57) Abstract The present invention relates to a skin-whitening composition and method for lightening skin pigmentation. The composition contains a blend of natural extracts, peptides, antioxidants, and whitening agents, such as alpha-arbutin, vitamin C, and niacinamide, formulated to inhibit melanin production in the skin. The cream is designed to penetrate the epidermis effectively, targeting hyperpigmentation and promoting an even skin tone without causing irritation or damage. Additional ingredients, including emollients and moisturizers, enhance the product's efficacy and provide skin hydration. The formulation can be used for reducing dark spots, acne scars, and other forms of pigmentation and is suitable for daily application.																																												
Figure 1: Whitening Cream Formulation																																												
<table border="1"><thead><tr><th>Ingredient</th><th>Function</th><th>Percentage (%)</th></tr></thead><tbody><tr><td>Aqua (Water)</td><td>Solvent, hydration</td><td>45%</td></tr><tr><td>Emollient Base (e.g., Squalane)</td><td>Moisturizes, enhances skin barrier</td><td>8%</td></tr><tr><td>Shea Butter</td><td>Emollient, softens skin</td><td>5%</td></tr><tr><td>Squalene Oil</td><td>Moisturizer, similar to skin's sebum</td><td>4%</td></tr><tr><td>Glycerin</td><td>Humectant, retains moisture</td><td>6%</td></tr><tr><td>Hyaluronic Acid (Low Molecular Weight)</td><td>Deep hydration, plumps skin</td><td>1%</td></tr><tr><td>Retinol</td><td>Anti-aging, improves cell turnover</td><td>0.5%</td></tr><tr><td>Niacinamide (Vitamin B3)</td><td>Brightening, improves elasticity</td><td>2%</td></tr><tr><td>Vitamin C (Ascorbic Acid or Stable Derivative)</td><td>Antioxidant, brightens skin</td><td>2%</td></tr><tr><td>Green Tea Extract</td><td>Antioxidant, soothes skin</td><td>1.5%</td></tr><tr><td>Preservative (Phenoxyethanol)</td><td>(e.g., prevents microbial growth</td><td>0.5%</td></tr><tr><td>Fragrance or Essential Oil (optional)</td><td>Adds pleasant scent</td><td>0.5%</td></tr><tr><td>pH Adjuster (e.g., Citric Acid)</td><td>Adjusts pH to match skin's natural pH</td><td>0.5 %</td></tr></tbody></table>	Ingredient	Function	Percentage (%)	Aqua (Water)	Solvent, hydration	45%	Emollient Base (e.g., Squalane)	Moisturizes, enhances skin barrier	8%	Shea Butter	Emollient, softens skin	5%	Squalene Oil	Moisturizer, similar to skin's sebum	4%	Glycerin	Humectant, retains moisture	6%	Hyaluronic Acid (Low Molecular Weight)	Deep hydration, plumps skin	1%	Retinol	Anti-aging, improves cell turnover	0.5%	Niacinamide (Vitamin B3)	Brightening, improves elasticity	2%	Vitamin C (Ascorbic Acid or Stable Derivative)	Antioxidant, brightens skin	2%	Green Tea Extract	Antioxidant, soothes skin	1.5%	Preservative (Phenoxyethanol)	(e.g., prevents microbial growth	0.5%	Fragrance or Essential Oil (optional)	Adds pleasant scent	0.5%	pH Adjuster (e.g., Citric Acid)	Adjusts pH to match skin's natural pH	0.5 %		
Ingredient	Function	Percentage (%)																																										
Aqua (Water)	Solvent, hydration	45%																																										
Emollient Base (e.g., Squalane)	Moisturizes, enhances skin barrier	8%																																										
Shea Butter	Emollient, softens skin	5%																																										
Squalene Oil	Moisturizer, similar to skin's sebum	4%																																										
Glycerin	Humectant, retains moisture	6%																																										
Hyaluronic Acid (Low Molecular Weight)	Deep hydration, plumps skin	1%																																										
Retinol	Anti-aging, improves cell turnover	0.5%																																										
Niacinamide (Vitamin B3)	Brightening, improves elasticity	2%																																										
Vitamin C (Ascorbic Acid or Stable Derivative)	Antioxidant, brightens skin	2%																																										
Green Tea Extract	Antioxidant, soothes skin	1.5%																																										
Preservative (Phenoxyethanol)	(e.g., prevents microbial growth	0.5%																																										
Fragrance or Essential Oil (optional)	Adds pleasant scent	0.5%																																										
pH Adjuster (e.g., Citric Acid)	Adjusts pH to match skin's natural pH	0.5 %																																										



গণপ্রজাতন্ত্রী বাংলাদেশ সরকার
পেটেন্ট, শিল্প-নকশা ও ট্রেডমার্কস অধিদপ্তর
শিল্প মন্ত্রণালয়
৯১, মতিঝিল বা/এ, ঢাকা-১০০০
www.dpdt.gov.bd

Publication of Filed Patent Application
Publication No: 33 & Date: 21 June 2026

(11) Patent registration No and date , (21) Appl. No. BD-P-2024-344 (22) Filed: 17/11/2024
(23) Priority Data: China, Number :2023115285563, Date : 16-11-2023.
(71) Applicant: Qingdao Hengnengda Energy Technologies Co., Ltd. of Room 2501, Unit 1, Building 4, No. 18 Yinchuan East Road, Laoshan District, Qingdao 266000, Shandong Province, Nationality -China
(72) Inventors: (1) ZHANG Yongheng of Room 2304, Building 8, No. 72 Liaoyang East Road, Laoshan District, Qingdao 266000, Shandong Province , China Nationality -China
(74) Agent : Rasheduzzaman Khokon, Advocate, Flat: G, Plot:638, Road:09 Avn: 03, Mirpur DOHS, Dhaka-1216., Bangladesh
(51) INT. CL. : F02B 3/06
(54) Invention Title: A method to promote combustion of combustibile and enhance power output and usage life of combustion equipment
(57) Abstract



গণপ্রজাতন্ত্রী বাংলাদেশ সরকার
পেটেন্ট, শিল্প-নকশা ও ট্রেডমার্কস অধিদপ্তর
শিল্প মন্ত্রণালয়
৯১, মতিঝিল বা/এ, ঢাকা-১০০০
www.dpdt.gov.bd

Publication of Filed Patent Application
Publication No: 33 & Date: 21 June 2026

(11) Patent registration No and date , (21) Appl. No. BD-P-2024-345 (22) Filed: 17/11/2024	
(23) Priority Data: United States of America, Number :63600654, Date : 18-11-2023.	
(71) Applicant: Bara Wahbeh of Jamil Alss Street, building 1, Apartment 6, Amman, 11191, Nationality -Jordan, Ching Man Mui of Jamil Alss Street, building 1, Apartment 6, Amman, 11191, Nationality -Jordan, Tan Xin Ning Sophia of Jamil Alss Street, building 1, Apartment 6, Amman, 11191, Nationality -Jordan	
(72) Inventors: (3) Bara Wahbeh of c/o Jamil Alss Street, building 1, Apartment 6, Amman, 11191, Jordan Nationality -Jordan, (4) Ching Man Mui of c/o Tsing Yi, Hong Kong Nationality -Hong Kong, (5) Tan Xin Ning Sophia of c/o 17 Scara drive, Singapore 807513, Singapore Nationality -Singapore	
(74) Agent : ISLAM & CO., 19/D (3rdFloor), East Noyatola, Mogh Bazar, Dhaka -1217, Bangladesh	
(51) INT. CL. : B01D 59/18	
(54) Invention Title: LIQUID-SOLID SEPARATOR IN SANITATION	
(57) Abstract The separator serves to separate solid and liquid waste from defecation and urination, for use especially in the field of sanitation and fecal waste management. Liquids and solids are separately channeled out of the separator body through different outlets, and can be channeled into separate systems. The present invention can realize instant separation of solid and liquid waste, achieving a lower liquid to solid ratio in fecal containment devices, lower pathogenic loads in the liquid waste, and enabling separate management of liquids and solids. In certain embodiments, an effluent treatment method is attached to treat the captured liquids. In certain embodiments, a solid treatment method is attached to treat the captured solids.	<p>FIG. 1</p>



গণপ্রজাতন্ত্রী বাংলাদেশ সরকার
পেটেন্ট, শিল্প-নকশা ও ট্রেডমার্কস অধিদপ্তর
শিল্প মন্ত্রণালয়
৯১, মতিঝিল বা/এ, ঢাকা-১০০০
www.dpdt.gov.bd

Publication of Filed Patent Application
Publication No: 33 & Date: 21 June 2026

(11) Patent registration No and date , (21) Appl. No. BD-P-2024-346 (22) Filed: 17/11/2024
(23) Priority Data: United States of America, Number :63601354, Date : 21-11-2023.
(71) Applicant: Monsanto Technology LLC of 800 North Lindbergh Boulevard, St. Louis, Missouri 63167, Nationality -United States of America
(72) Inventors: (1) SRIDHARAN, Krishnakumar of 800 North Lindbergh Boulevard St. Louis, Missouri 63167, United States of America Nationality -India
(74) Agent : Rana & Associates, Nipobon Asgar Garden, 462, Green Way, Flat No. A/2 (2nd Floor), Moghbazar, Dhaka-1217, Bangladesh
(51) INT. CL. : C07K 14/415
(54) Invention Title: PLANT REGULATORY ELEMENTS AND USES THEREOF
(57) Abstract Recombinant DNA polynucleotides and constructs, as well as their nucleotide sequences, useful for modulating gene expression in plants are provided. Also, transgenic plants, plant cells, plant parts, and seeds comprising the recombinant DNA polynucleotides operably linked to heterologous transcribable DNA polynucleotides are provided. Also provided are methods of the use of the recombinant DNA polynucleotides and constructs.



গণপ্রজাতন্ত্রী বাংলাদেশ সরকার
পেটেন্ট, শিল্প-নকশা ও ট্রেডমার্কস অধিদপ্তর
শিল্প মন্ত্রণালয়
৯১, মতিঝিল বা/এ, ঢাকা-১০০০
www.dpdt.gov.bd

Publication of Filed Patent Application
Publication No: 33 & Date: 21 June 2026

(11) Patent registration No and date , (21) Appl. No. BD-P-2024-348 (22) Filed: 18/11/2024	
(23) Priority Data: Republic of Korea, Number :1020230163460, Date : 22-11-2023.	
(71) Applicant: KOREA ZINC CO., LTD. of 33, Jong-ro, Jongno-gu, Seoul 03159, Nationality -Republic of Korea	
(72) Inventors: (1) KIM, Seung Hyun of 308-1101, 245 Jongga-ro, Jung-gu, Ulsan 44536, Republic of Korea Nationality -Republic of Korea, (2) LEE, Woll Seung of 303, 12-25 Seoyeongnam2-gil, Onsan-eup, Ulju-gun, Ulsan 45003, Republic of Korea Nationality -Republic of Korea	
(74) Agent : Shahid & Alliance, 30/3 B C Das Street, Lalbagh, Dhaka-1205, Bangladesh	
(51) INT. CL. : F02K 9/52	
(54) Invention Title: SYSTEM AND METHOD FOR CONTROLLING AUTO-PUSH OF INJECTOR	
(57) Abstract The technical idea of the present disclosure provides an auto-push control system comprising: a reactor comprising an outer wall; an injector configured to penetrate the outer wall of the reactor and be inserted into the reactor; a sensor placed in the injector; and a controller configured to control an insertion distance or an insertion rate of the injector into the reactor, wherein the controller is further configured to: calculate a loss length of the injector based on a signal from the sensor; and compensate for the insertion distance of the injector based on an insertion length depending on a preset insertion rate of the injector and the calculated loss length of the injector.	



গণপ্রজাতন্ত্রী বাংলাদেশ সরকার
পেটেন্ট, শিল্প-নকশা ও ট্রেডমার্কস অধিদপ্তর
শিল্প মন্ত্রণালয়
৯১, মতিঝিল বা/এ, ঢাকা-১০০০
www.dpdt.gov.bd

Publication of Filed Patent Application
Publication No: 33 & Date: 21 June 2026

(11) Patent registration No and date , (21) Appl. No. BD-P-2024-349 (22) Filed: 20/11/2024	
(23) Priority Data: United States of America, Number :63601948, Date : 22-11-2023. and United States of America, Number :63677136, Date : 30-07-2024.	
(71) Applicant: CRINETICS PHARMACEUTICALS, INC. of 6055 Lusk Blvd San Diego, California 92121, Nationality -United States of America	
(72) Inventors: (1) KIM, Sun Hee of 6055 Lusk Blvd San Diego, California 92121, Republic of Korea Nationality - Republic of Korea, (2) ZHU, Yunfei of 6055 Lusk Blvd San Diego, California 92121, United States of America Nationality -United States of America	
(74) Agent : H & H COMPANY, Shareef Mansion (Second Floor), 56-57, Motijheel C/A, Dhaka-1000, Bangladesh	
(51) INT. CL. : C07K 14/655	
(54) Invention Title: SOMATOSTATIN SUBTYPE RECEPTOR 3 (SSTR3) AGONISTS AND USES THEREOF	
(57) Abstract Described herein are compounds that are somatostatin receptor subtype 3 (SSTR3) agonists, methods of making such compounds, pharmaceutical compositions and medicaments comprising such compounds, and methods of using such compounds in the treatment of conditions, diseases, or disorders that would benefit from modulation of SSTR3 activity.	



গণপ্রজাতন্ত্রী বাংলাদেশ সরকার
পেটেন্ট, শিল্প-নকশা ও ট্রেডমার্কস অধিদপ্তর
শিল্প মন্ত্রণালয়
৯১, মতিঝিল বা/এ, ঢাকা-১০০০
www.dpdt.gov.bd

Publication of Filed Patent Application
Publication No: 33 & Date: 21 June 2026

(11) Patent registration No and date , (21) Appl. No. BD-P-2024-350 (22) Filed: 21/11/2024	
(23) Priority Data: India, Number :202321080085, Date : 24-11-2023.	
(71) Applicant: Indian Oil Corporation Limited of Indian Oil Bhavan, G-9, Ali Yavar Jung Marg, Bandra (East), Mumbai-400 051, Maharashtra, Nationality -India	
(72) Inventors: (0) KUMAR, Manoj of Indian Oil Corporation Limited, R&D Centre, Sector-13, Faridabad-121007, Haryana, India Nationality -India, (1) SANDIPAM, Srikanth of Indian Oil Corporation Limited, R&D Centre, Sector-13, Faridabad-121007, Haryana, India Nationality -India, (2) GUPTA, Ravi Prakash of Indian Oil Corporation Limited, R&D Centre, Sector-13, Faridabad-121007, Haryana, India Nationality -India, (3) BHATTACHARYYA, Debasis of Indian Oil Corporation Limited, R&D Centre, Sector-13, Faridabad-121007, Haryana, India Nationality -India, (4) RAMAKUMAR, Sankara Sri Venkata of Indian Oil Corporation Limited, R&D Centre, Sector-13, Faridabad-121007, Haryana, India Nationality -India	
(74) Agent : Munshi & Associates, 194/D/1, Tejkunipara, Tejgaon, Dhaka-1215 , Bangladesh	
(51) INT. CL. : C02F 3/34	
(54) Invention Title: PROCESS FOR STABILIZATION OF NUTRIENT RICH RESIDUE AND PREPARATION OF ENRICHED FERMENTED ORGANIC MANURE	
(57) Abstract The present invention relates to the process for preparing enriched organic manure comprises the steps of biomethanating nutrient rich residue from digesters to obtain fermented organic manure; mixing microbial blend 1; adding microbial stimulant 1; optionally adding microbial stimulant 2; and adding microbial blend 2 to obtain enriched fermented organic manure. The process for preparing enriched liquid organic manure comprises the steps of biomethanating nutrient rich residue from digesters to obtain fermented organic manure; mixing microbial blend 1; adding microbial stimulant 1; and adding microbial blend 2 to obtain enriched fermented organic manure. a process for stabilization of a nutrient rich residue and preparation of an enriched fermented organic manure. It includes synergistic combination of different microbes which can harmoniously work together and mutually promote the composting process with each other's advantages.	



গণপ্রজাতন্ত্রী বাংলাদেশ সরকার
পেটেন্ট, শিল্প-নকশা ও ট্রেডমার্কস অধিদপ্তর
শিল্প মন্ত্রণালয়
৯১, মতিঝিল বা/এ, ঢাকা-১০০০
www.dpdt.gov.bd

Publication of Filed Patent Application
Publication No: 33 & Date: 21 June 2026

(11) Patent registration No and date , (21) Appl. No. BD-P-2024-351 (22) Filed: 24/11/2024																									
(23) Priority Data: Republic of Korea, Number :1020230166694, Date : 27-11-2023.																									
(71) Applicant: CJ CHEILJEDANG CORPORATION of 330, Dongho-ro, Jung-gu, Seoul 04560, Nationality - Republic of Korea																									
(72) Inventors: (1) YOON, Jeong-Hye of 330, Dongho-ro, Jung-gu, Seoul 04560, Republic of Korea Nationality - Republic of Korea, (2) PARK, Goun of 330, Dongho-ro, Jung-gu, Seoul 04560, Republic of Korea Nationality - Republic of Korea, (3) BAE, Jee Yeon of 330, Dongho-ro, Jung-gu, Seoul 04560, Republic of Korea Nationality - Republic of Korea, (4) KIM, Hyung Joon of 330, Dongho-ro, Jung-gu, Seoul 04560, Republic of Korea Nationality - Republic of Korea																									
(74) Agent : Rana & Associates, Nipobon Asgar Garden, 462, Green Way, Flat No. A/2 (2nd Floor), Moghbazar, Dhaka-1217, Bangladesh																									
(51) INT. CL. : C12N 15/113																									
(54) Invention Title: NOVEL PROMOTER AND USE THEREOF																									
(57) Abstract Provided are a novel promoter and a method of producing a target product using the same. The polynucleotide of the present disclosure has promoter activity, and may efficiently control the expression and activity of a target gene in a microorganism, and may be usefully applied in efficiently producing the target product.	<table border="1"><caption>Fluorescence intensity data</caption><thead><tr><th>Sample</th><th>Fluorescence Intensity</th></tr></thead><tbody><tr><td>c7</td><td>5000</td></tr><tr><td>M1</td><td>28000</td></tr><tr><td>M2</td><td>35000</td></tr><tr><td>M3</td><td>24000</td></tr><tr><td>M4</td><td>29000</td></tr><tr><td>M5</td><td>24000</td></tr><tr><td>M6</td><td>27000</td></tr><tr><td>M7</td><td>40000</td></tr><tr><td>M8</td><td>30000</td></tr><tr><td>M9</td><td>32000</td></tr><tr><td>M10</td><td>24000</td></tr></tbody></table>	Sample	Fluorescence Intensity	c7	5000	M1	28000	M2	35000	M3	24000	M4	29000	M5	24000	M6	27000	M7	40000	M8	30000	M9	32000	M10	24000
Sample	Fluorescence Intensity																								
c7	5000																								
M1	28000																								
M2	35000																								
M3	24000																								
M4	29000																								
M5	24000																								
M6	27000																								
M7	40000																								
M8	30000																								
M9	32000																								
M10	24000																								



গণপ্রজাতন্ত্রী বাংলাদেশ সরকার
পেটেন্ট, শিল্প-নকশা ও ট্রেডমার্কস অধিদপ্তর
শিল্প মন্ত্রণালয়
৯১, মতিঝিল বা/এ, ঢাকা-১০০০
www.dpdt.gov.bd

Publication of Filed Patent Application
Publication No: 33 & Date: 21 June 2026

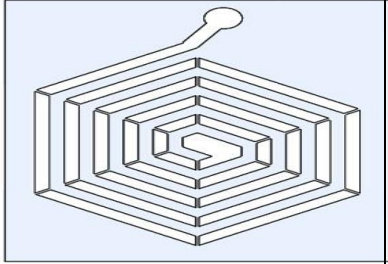
(11) Patent registration No and date , (21) Appl. No. BD-P-2024-352 (22) Filed: 25/11/2024
(23) Priority Data: India, Number :202421054977, Date : 18-07-2024.
(71) Applicant: GODREJ CONSUMER PRODUCTS LIMITED of 4th Floor Godrej One, Pirojshanagar, Eastern Express Highway, Vikhroli East, Mumbai – 400079, Maharashtra, Nationality -India
(72) Inventors: (1) BIBALS, Reena of Godrej Consumer Products Ltd., 4th Floor, Godrej One, Pirojshanagar, Eastern Express Highway, Vikhroli (East), Mumbai 400079, Maharashtra, India Nationality -India, (2) YADLAPALLI, Venkateswara of Godrej Consumer Products Ltd., 4th Floor, Godrej One, Pirojshanagar, Eastern Express Highway, Vikhroli (East), Mumbai 400079, Maharashtra, India Nationality -India, (3) PENDOTA, Bhargava of Godrej Consumer Products Ltd., 4th Floor, Godrej One, Pirojshanagar, Eastern Express Highway, Vikhroli (East), Mumbai 400079, Maharashtra, India Nationality -India, (4) K Marisamy of Godrej Consumer Products Ltd., 4th Floor, Godrej One, Pirojshanagar, Eastern Express Highway, Vikhroli (East), Mumbai 400079, Maharashtra, India Nationality -India, (5) CHOUGHULE, Uday of Godrej Consumer Products Ltd., 4th Floor, Godrej One, Pirojshanagar, Eastern Express Highway, Vikhroli (East), Mumbai 400079, Maharashtra, India Nationality -India
(74) Agent : ADVANCED IP LAW FIRM, Suite# 9/C (9th floor), Fahima tower, 42-43, purana palton, Dhaka-1000, Bangladesh
(51) INT. CL. : A24D 1/02
(54) Invention Title: SUBSTRATE – COATED NOVEL COMBUSTIBLE COMPOSITION
(57) Abstract Described herein is a novel substrate coated vapour emitting composition for delivery of combustible substance, which integrates active ingredient emanation with burning-aided materials coated on to the surface of a paper in which the coated portion will undergo smouldering to release active ingredient

Fig. 1

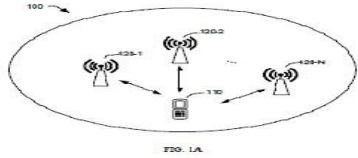
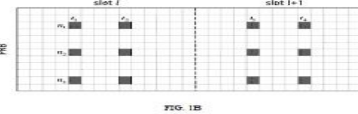

গণপ্রজাতন্ত্রী বাংলাদেশ সরকার
 পেটেন্ট, শিল্প-নকশা ও ট্রেডমার্কস অধিদপ্তর
 শিল্প মন্ত্রণালয়
 ৯১, মতিঝিল বা/এ, ঢাকা-১০০০
www.dpdt.gov.bd

Publication of Filed Patent Application
Publication No: 33 & Date: 21 June 2026

(11) Patent registration No and date ,	
(21) Appl. No. BD-P-2024-354	
(22) Filed: 27/11/2024	
(23) Priority Data: China, Number :2024078450, Date : 23-02-2024.	
(71) Applicant: Nokia Technologies Oy of Karakaari 7, 02610 Espoo, Nationality -Finland	
(72) Inventors: (0) Hao LIU of #388 Ningqiao Road, Pudong JinQiao, Shanghai, 201206, China Nationality -China, (1) Filippo TOSATO of 37, Avenue du Général de Gaulle, Villebon sur Yvette, 91140, France Nationality -Italy, (2) Rana AHMED of Terofalstr 3, Munich, 80869, Germany Nationality -Germany, (3) Tao YANG of 3B-D400, 388, Ningqiao Rd., Shanghai, 201206, China Nationality -China	
(74) Agent : REMFRY & SON, 56 NEW ESKATON ROAD, 4TH FLOOR DHAKA-1000, DHAKA, Bangladesh	
(51) INT. CL. : G01F 25/17	
(54) Invention Title: INTER-TRP CALIBRATION	
(57) Abstract Embodiments of the present disclosure relate to inter-transmit-receive point (TRP) calibration. In an aspect, a terminal device determines, from a plurality of RS resource sets, one or more of a first reference RS resource set and a second reference RS resource set. Moreover, the terminal device transmits, to at least one network device of a plurality of network devices associated with the plurality of RS resource sets, one or more of: time misalignment information for a first RS resource set of the plurality of RS resource sets relative to the first reference RS resource set; or frequency offset information for a second RS resource set of the plurality of RS resource sets relative to the second reference RS resource set.	 <p>FIG. 1A</p>  <p>FIG. 1B</p>