

Structural Designs for the BRRI Compact Rice Mill

Part 1



AKM Saiful Islam

Structural Designs for the BRRI Compact Rice Mill

Part 1

AKM Saiful Islam



Bangladesh Rice Research Institute

Structural Designs for the BRRI Compact Rice Mill

Part 1



AKM Saiful Islam

First published : March 2024

Publication no. : 401

Number of copies : 300

Copyright : Bangladesh Rice Research Institute

Cover page design : Dr. AKM Saiful Islam

Communication : Publication and public relation division
Bangladesh Rice Research Institute, Gazipur
Bangladesh

Printed by : **Tithy Printing & Packaging**
28/C-1, Toyenbee Circular Road, Motijheel C/A
Dhaka-1000, Cell : 01819263481

Engineering drawing

Drawn by : **Shafier Jahan Khan**
Mechanical Engineer, B.Sc. (Hons.)
Research Assistant, SFMRA project
Bangladesh Rice Research Institute (BRRI)

Checked by : **Professor Dr. Md. Mosharraf Hossain**
Department of Farm Power and Machinery
Bangladesh Agricultural University

Approved by : **Dr. AKM Saiful Islam**
Chief Scientific Officer
Farm Machinery and Postharvest Technology Division
Bangladesh Rice Research Institute

Citation

Islam, AKM Saiful 2024: Structural Designs for the BRRI compact rice mill (Part 1). Bangladesh Rice Research Institute, Gazipur, Bangladesh

Acknowledgment:

Special thanks to Salam Engineering Workshop, Dinajpur and all those who directly and indirectly helped in the preparation of this book.

Preface

The BRRRI compact rice mill is a modern rice milling machinery. Various components including rice, bran, and husk are efficiently discharged through distinct delivery lines in a single pass. This machine uses of two rubber rollers, a blower, and a polisher, collectively contributing to the production of rice and closely resembles that of a large auto rice mill but at a significantly lower cost. The machine can be produced in a local workshop using indigenous raw materials, emphasizing accessibility and sustainability. The publication named " Structural Designs for the BRRRI compact rice mill (Part 1 and 2)" comprises comprehensive engineering drawings for every component of the BRRRI compact rice mill. This comprehensive guide aims to provide engineers, manufacturers, technicians, and all stakeholders involved in the rice milling process with detailed insights into the design and specifications of the BRRRI compact rice mill. Each drawing is a visual representation of the careful considerations that have gone into the development of this model. This publication is a collaborative endeavor aimed at sharing knowledge, fostering innovation, and contributing to the advancement of rice milling technology. We extend our gratitude to all contributors involved in the preparation of this valuable resource. May this guide serve as a foundation for the successful implementation, operation, and continuous improvement of the BRRRI compact rice mill.



Director General
Bangladesh Rice Research Institute

Foreword

The Farm Machinery and Postharvest Technology Division of the Bangladesh Rice Research Institute is currently executing the project named "Strengthening Farm Machinery Research Activity for Mechanized Rice Cultivation (SFMRA)". Under the supervision of Dr. AKM Saiful Islam, Agricultural Engineers of BRRRI developed the compact rice mill using indigenous raw materials in a local workshop. It is with great pleasure that I introduce this exceptional publication, "Structural Designs for the BRRRI compact rice mill (Part 1 and 2)" compiled by Dr. AKM Saiful Islam. This publication stands as a base in the realm of rice milling technology, offering an in-depth exploration of the design, construction, and functionality of the BRRRI compact rice mill. Dr. Islam's dedication and expertise in the field of agricultural engineering have been pivotal in shaping the content of this book. His meticulous compilation of engineering drawings provides a comprehensive guide for engineers, manufacturers, researchers, and enthusiasts who seek to understand the intricacies of the BRRRI compact rice mill. I extend my sincere appreciation to Dr. AKM Saiful Islam for his dedication to knowledge dissemination and his invaluable contribution to the field of agricultural engineering. May this publication inspire further research, development, and collaborative efforts in advancing rice processing technology.

A handwritten signature in blue ink, consisting of stylized initials and a surname.

(Dr. Md. Shahjahan Kabir)



Chief Scientific Officer
Farm Machinery and Postharvest Technology Division
BIRRI, Gazipur

About Project Director

Dr. AKM Saiful Islam graduated from the Department of Farm Power and Machinery, Bangladesh Agricultural University, Mymensingh and received chancellor award for achieving first position in graduate course. Dr. Islam obtained MS degree from the same university in 1996. He completed postgraduate diploma course from Silsoe College, UK in 1997. Dr. Islam obtained PhD in Agricultural Engineering from the Department of Farm Power and Machinery, Bangladesh Agricultural University, Mymensingh in 2012. He started his career as a Scientific Officer in Farm Machinery and Postharvest Technology Division of Bangladesh Rice Research Institute in 1998. Dr. Islam developed training manual for seedling raising techniques, BIRRI weeder, rice-wheat reaper, BIRRI open drum thresher, BIRRI rice-wheat thresher, BIRRI panicle thresher, BIRRI whole feed combine harvester. He is involved in the invention and development of mechanized seedling raising techniques, BIRRI seed sower, BIRRI auto seed sower, BIRRI rice transplanter, BIRRI semi automatic rice transplanter, BIRRI solar light trap, BIRRI urea super granular fertilizer, BIRRI power weeder, BIRRI rice-wheat reaper, BIRRI rice-wheat thresher, BIRRI panicle thresher, BIRRI whole feed combine harvester, BIRRI head feed combine harvester, BIRRI straw rope maker, BIRRI air blow rice mill, BIRRI compact rice mill, BIRRI mini rice huller and BIRRI short and long rice processing technology. At present, he is working as a Chief Scientific Officer and project director of the project "Strengthening Farm Machinery Research Activity for Mechanized Rice Cultivation (SFMRA)".

About project

The project "Strengthening Machinery Research Activity for Mechanized Rice Cultivation" was approved for implementation from July 2019 to June 2025 at an estimated cost of Tk 4400 Lakhs. The project is being implemented by the Farm Machinery and Postharvest Technology Division of Bangladesh Rice Research Institute under the Ministry of Agriculture in 12 upazilas of 12 districts of seven divisions of the country. The main objective is to strengthen farm machinery research activities for sustainable rice cultivation. The specific objectives are (a) Developing nine agricultural machinery and technologies suitable to the socio-economic condition of the farmers: i.e. rice transplanter, mini combine harvester, power weeder, reaper binder, compact rice mills, rice transplanter-cum-fertilizer, straw rope maker, seed sower machines, post-harvest management and renewable energy (solar and briquette machines); (b) Further development of the machinery by collecting feedback from the stakeholder through 324 adaptive trials; (c) Providing hands-on training to 6480 machine operators, farmers, mechanics and service providers and 200 local agricultural machinery manufacturers and extension officers/workers to increase their skills on modern agricultural machinery; (d) Capacity building of 20 scientists and 20 workshop workers for the research on modern agricultural machinery through higher education and training; and (e) Modernization of existing farm machinery research lab-cum-workshop. The project activities are a) Developing nine agricultural machinery and post-harvest technologies suitable for sustainable rice production i.e. rice transplanter, combine harvester, power weeder, reaper binder, compact rice mill, rice transplanter-cum-fertilizer, straw rope maker, seed sower machine, post-harvest management and renewable energy (solar and briquette machines); b) To procure prototypes from abroad and preparing indigenously adapted machines through reverse engineering and applied research; c) To develop machine according to the feedback obtained through practical field tests; d) To conduct 324 two-day residential hands-on training on seedling raising techniques, operation, repair and maintenance of rice transplanters for mechanized rice transplanting; e) To sensitize 6480 farmers, machine operators, mechanics, farmer groups/farmers associations, service providers about utility of agricultural machinery, operating techniques, repair and maintenance through 324 practical field tests of BIRRI developed modern machinery; f) To publish the training schedule and names of the trainees in the form of a database on the BIRRI web site to maintain transparency and accountability in the training program and to avoid duplicity in the selection of trainees; g) Developing 10 skilled scientific manpower through three months of overseas training; h) To organize short term (7-10 days) training of 10 scientists in agricultural machinery manufacturing countries; j) Conducting 10 trainings of three days duration on transfer of machinery technology to the farm machinery manufacturers/extension officers/workers; j) To enhance quality research skills by establishing machine testing lab (375 square meters) with modern equipment for machinery quality control; k) Develop a commercial approach to agriculture through limited long-term use of farm machinery and rental machinery service providers in the project area; l) Building co-operation between researchers, extension workers, manufacturers and farmers; d) Development of 2,500 cubic meter research field/plot for head office research; d) Vertical extension (450 square meters) of farm machinery lab cum office building at head office; n) Construction of machinery display cum ware house (150 sq m to 750 sq m in 5 Regional stations) for display room at BIRRI Regional stations; (v) Skilling of 20 workshop workers through training in machine prototyping, repair and maintenance; d) To provide necessary technical assistance to the entrepreneurs and machinery manufacturing institutions/factories serving through the Department of Agriculture Extension for ensuring the use of sustainable agricultural machinery at the field level. Recruiting 11 persons (one office assistant cum computer programmer, two bench mechanics, two lathe-operators, two tin smiths, two hammer men and two drivers) through outsourcing to support the project director in project execution. Scientists of FMPHT division, research assistants, Accountant of Accounts division and staff of Planning and Evaluation Division are working on the project as additional responsibilities.

BRRI compact rice mill

Purpose of developing the machine

Increase milling recovery: One of the purposes is to increase milling recovery. This suggests a focus on optimizing the efficiency of the rice milling process, aiming to extract a higher quantity of rice from the paddy. Increased milling recovery is crucial for maximizing the yield and economic output from each batch of paddy processed.

Quality rice production: Another purpose is to produce quality rice by separating the bran and husk. Separating the bran and husk allows for the production of rice with improved nutritional content, contributing to better overall food quality.

Building business success machines for small entrepreneurs: The purpose of building business success machines for small entrepreneurs highlights the socio-economic aspect of the initiative. This mill is not only efficient but also economically viable with low investment requirements. The goal of developing the machine is to empower small entrepreneurs. This could lead to the establishment and growth of small businesses in the rice milling sector, contributing to local economic development.

Characteristics

The characteristics of the BRRI compact rice mill highlight its key specifications and features, emphasizing its efficiency, ease of use, and economic viability.

Motor specification: The rice mill is equipped with a 3-phase 25 hp 1450 rpm motor. Single phase 3 hp 1450 rpm motor for the elevator. Single phase 1 hp 1450 rpm motor for the precleaner. This indicates a powerful motor suitable for processing rice efficiently.

Processing capacity: The machine can mill more than 650 kg of paddy per hour, demonstrating a high processing capacity. This feature is beneficial for handling substantial quantities of paddy within a relatively short timeframe.

Quality of rice: The rice mill produces good-quality brown and white rice. Additionally, the low rice breakage suggests that the milling process is designed to preserve the integrity of the rice grains, contributing to overall rice quality.

Ease of operation: The machine is described as easy to operate, indicating that users, including those with limited technical expertise, can effectively use the technology. This characteristic is crucial for widespread adoption.

Business viability: The statement emphasizes that the rice mill is a successful business machine with low investment. This suggests that the technology is economically viable and can be an attractive option for entrepreneurs or farmers looking to invest in rice milling with a relatively low financial commitment.

The BRRI compact rice mill combines technical capabilities, efficiency, user-friendliness, and economic viability, making it a promising solution for rice processing with the potential for positive impacts on both agricultural productivity and local entrepreneurship.

Technical Specification

Name : BRRRI Compact Rice Mill

Model: BRRRI RM2023

Taking, l=length, w=width, h=height, t=thickness, Ø=diameter, r=radius.

1. Machine l=1850mm, h=530mm, w=800mm. Made of (75x40x5) mm C-Channel.
2. Motor casing l=668mm, w=620mm. Made of (50x50x4) mm angle bar.
3. Motor is 25 hp, 1450rpm, three phase.
4. Motor pulley Ø=180mm, t=72.5mm.
5. Husk out line size (l=585.2, W=301.5, h=380, t=1.5) mm.
6. Upper holding part size (l=805, W=620, t=17) mm.
7. Main body size (L=805, w=617, h=1309, t=2) mm.
8. Rubber roller outer casing size (L=617, w=317, t=1.5) mm.
9. Conveyer auger cover size (l=508, w=326, t=1.5, r=202) mm.
10. Main body shell flange (Ø=382, t=1.5) mm.
11. Airline box part l=508mm, w=391.5mm, h=159mm, t=1.5mm.
12. Pre-cleaner size (w=620, l=1100, h=880) mm. Angle bar (50x50x3) mm.
13. Pre-cleaner motor carrier size (l=490, h=291.5) mm. Square bar (8x8) mm.
14. Cam Ø=40mm, h=20mm.
15. Pre-cleaner motor 1hp 1450rpm, single phase 200V.
16. Precleaned body casing (l=927.7, w=490, h=210, t=1.5) mm.
17. Mesh net size l=861mm, w=486mm, t=1.5mm. Quantity 01 (SS).
18. Elevator flange l=606mm, w=286mm. Angle bar size (38x38x4) mm. Quantity 07.
19. Elevator body size l=180mm, l=210mm, h=620, t=1.5mm. Quantity 01.
20. Elevator body size l=180mm, l=210mm, h=1600, t=1.5mm. Quantity 02.
21. Elevator pulley h=62mm, Ø=73mm.
22. Elevator flat belt pulley h=165mm, Ø=236mm. Quantity 02.
23. Elevator: Pillow block bearing housing UCP-207. Quantity 02.
24. Elevator shaft Ø=37mm, l=495mm.
25. Elevator motor 3HP, 1450rpm, single phase 200V.
26. Elevator buckets: Quantity 53.
27. Elevator pulley h=20.5mm, Ø=600mm.
28. Elevator: Face type bearing housing UCF-207. Quantity 02.
29. Elevator bottom casing (l=615, w=401, h=616, t=1.5).
30. Elevator bottom pulley shaft l=325mm, Ø=36mm.
31. Hopper size (Ø=645, h=400, t=1.5) mm.
32. Hopper pulley (Ø=195, h=16.5) mm.

33. Hopper bearing: 20X35X9-2RS Rubber sealed ball bearing. Quantity 02.
34. Hopper shaft ($\varnothing=21$, $l=420$) mm.
35. Blower flange ($\varnothing=302$, $h=65$) mm.
36. Blower fan ($\varnothing=250$, $h=78$) mm.
37. Blower jam nut ($\varnothing=45$, $t=6$) mm.
38. Blower size ($l=450$, $w=500$, $t=1.5$) mm sheet needed in each size.
39. Blower hose (PVC) pipe with inner $\varnothing=95$ mm.
40. Cyclone size ($l=350$, $w=400$, $h=871$ $t=1.5$) mm sheet needed in each size.
41. Blower: Face type bearing housing UCF-207. Quantity 02.
42. Blower shaft ($\varnothing=37.5$, $l=784$) mm.
43. Blower pulley (CI) size $\varnothing=178$ mm, $h=71$ mm.
44. Polisher housing size ($l=305$, $w=184.8$, $r=92.5$) mm.
45. Polisher shell net size $l=301$ mm, each hand distance= 56 mm.
46. Polisher blower 0.5hp, 1450 rpm, single phase 200V.
47. Polisher Radial Ball Bearing_68_SKF. Quantity 01.
48. Polisher worm gear size $\varnothing=91$ mm, $l=105$ mm, pitch= 03 .
49. Polisher bearing: NSK 6314. Quantity 01.
50. Polisher pulley $\varnothing=255$ mm, $l=132$ mm. V-groove, Type-B, Slot number= 05 .
51. Size grader size ($l=1010$, $w=455$, $h=271$) mm.
52. Size grader pulley ($\varnothing=94$, $t=40$) mm.
53. Size grader bearing: 6208 Ball Bearing. Quantity 01.
54. Size grader: Bearing Housing UCP-204. Quantity 10.
55. Size grader casing size ($l=640$, $w=360$, $h=110$) mm.
56. Size grader: Mesh net (SS): 14 and 16 number net from the market.
57. Rubber roller setting body: Adjusting clamp ($l=352$, $w=138$, $h=293$) mm.
58. Rubber roller setting body: Pin lock ($\varnothing=80$, $t=81$) mm.
59. Rubber roller setting body: HTFJ33-1G5C3(NSK) – BEARING. Quantity 04.
60. Rubber roller setting body: Shaft ($\varnothing=34$, $l=487$) mm. Quantity 02.
61. Rubber roller setting body: Gap Controller Shaft ($\varnothing=23$, $l=297$) mm. Quantity 01.
62. Rubber roller setting body: Rubber Roller 4 inch. Quantity 02.
63. Rubber roller setting body: Pulley-1 size ($\varnothing=127$, $l=92$) mm. Pulley-2 size ($\varnothing=178$, $l=91.5$) mm.
64. Tension: Pulley size ($\varnothing=158$, $l=41.9$) mm.
65. Husk conveyer: UCF-207 bearing housing. Quantity 02.
66. Husk conveyer: Pulley size ($\varnothing=298$, $l=52$) mm.
67. Grader pulley: ($\varnothing=98$, $l=40$) mm.
68. V-Groove Type-A and Type-b belts. Model no: B-70, B-104, B-93, A-36, BB-124.
69. Safety guard: ($l=1313$, $w=939$, $h=209.4$, $t=1.5$) mm.

INDEX

SUB-ASSEMBLY NO.	DESCRIPTION	SHEET NO	PAGE NO.
1	SUB-ASSEMBLY	01 - 29	1
2	S-1_BASE SUB-ASSEMBLY	30 - 41	30
3	S-2_MAIN BODY-SUB-ASSEMBLY	42 - 80	42
4	S-3_PRECLEANER_SUB-ASSEMBLY	81 - 98	81
5	S-4_ELEVATOR_SUB-ASSEMBLY	99 - 134	99
6	S-5_HOPPER SUB-ASSEMBLY	135 - 156	135

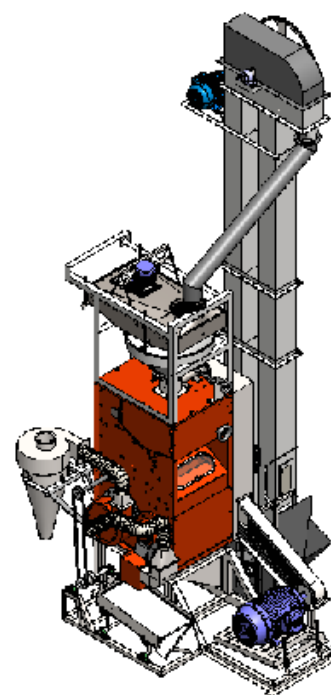

ISOMETRIC VIEW



ASSEMBLY VIEW OF (BRRI RM2023)

ASSEMBLY NO.	DESCRIPTION	PART NO.	QTY.
01.	S-1_BASE SUB-ASSEMBLY	RM2023_S1-A	1
02.	S-2_MAIN BODY SUB-ASSEMBLY	RM2023_S2-A	1
03.	S-3_NET FRAME CHALUNI SUB-ASSEMBLY	RM2023_S3-A	1
04.	S-4_ELEVATOR SUB-ASSEMBLY	RM2023_S4-A	1
05.	S-5_HOPPER SUB-ASSEMBLY	RM2023_S5-A	1
6.A	S-6.A_CONVEYER BLOWER SUB-ASSEMBLY	RM2023_S-6.A-A	1
6.B	S-6.B_POLISHER SUB-ASSEMBLY	RM2023_S-6.B-A	1
6.C	S-6.C_POLISHER BLOWER SUB-ASSEMBLY	RM2023_S-6.C-A	1
6.D	S-6.D_POLISHER MECHANISM SUB-ASSEMBLY	RM2023_S-6.D-A	1
6.E	S-6.E_RICE DELIVERY SECTION SUB-ASSEMBLY	RM2023_S-6.E-A	1
6.F	6.F_SIZE GRADER SUB-ASSEMBLY	RM2023_S6.F-A	1
07.	S-7_RUBBER ROLLER SETTING BODY SUB-ASSEMBLY	RM2023_S-7-A	1
08.	S-8_TENSION PULLEY SUB-ASSEMBLY	RM2023_S8-A	1
09.	S-9_HUSK CONVEYER SUB-ASSEMBLY	RM2023_S-9-A	1
10.	V-BELT TYPE-B (MODEL: B-70)	RM2023_226	1
11.	V-BELT TYPE-B (MODEL: B-104)	RM2023_227	3
12.	V-BELT TYPE-BB (MODEL: BB-124)	RM2023_228	2
13.	V-BELT TYPE-B (MODEL: B-93)	RM2023_229	1
14.	V-BELT TYPE-A (MODEL: A-36)	RM2023_230	1
15.	MOTOR SAFETY CASING	RM2023_231	1
16.	PULLEY SAFETY CASING	RM2023_232	1

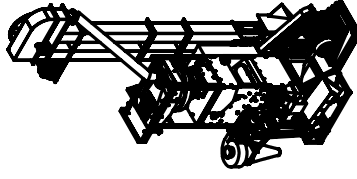

ISOMETRIC VIEW

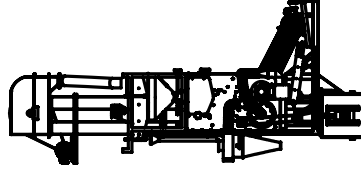

FRONT VIEW

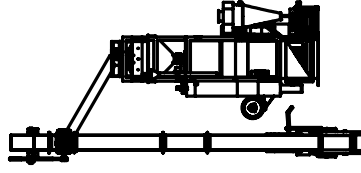

LEFT VIEW

		BANGLADESH RICE RESEARCH INSTITUTE SFMRA PROJECT, FMPT DIVISION		DO NOT SCALE DRAWING
				FINISH: NONE
				FIRST ISSUED: 02-AUG-2023
		TITLE: BRRI COMPACT RICE MILL (BRRI RM2023)		
		DRG. NAME: BRRI COMPACT RICE MILL ASSEMBLY		
		DWG NO: RM2023-A		
		MANUFACTURING METHOD: MOLDING, MACHINING, BENDING & WELDING		
		WEIGHT: 1199883.28 g		A4
		SCALE: 1:90		SHEET 1
		REVISION:		A

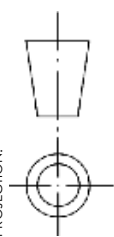
UNLESS OTHERWISE SPECIFIED: STD. TOLERANCE DIMENSIONS ARE IN MILLIMETER MILLIMETER: ±0.1, ANGULAR: ± 0.05° * DOES NOT APPLY TO HOLE SIZE		SIGNATURE S J K	DATE 03-DEC-2023
DRAWN ENGR. SHAFER JAHAN KHAN	CHECKED DR. MD. MOSHARRAF HOSSAIN	DATE 18-DEC-2023	DATE 30-DEC-2023
APPROVED DR. AKM SAIBUL ISLAM	THIRD ANGLE PROJECTION: 		

NOTE: DEBURR AND BREAK SHARP EDGES ALL BENDS MIN. RADIUS UNLESS SPECIFIED

EXPLODED VIEW OF (BRRI RM2023)

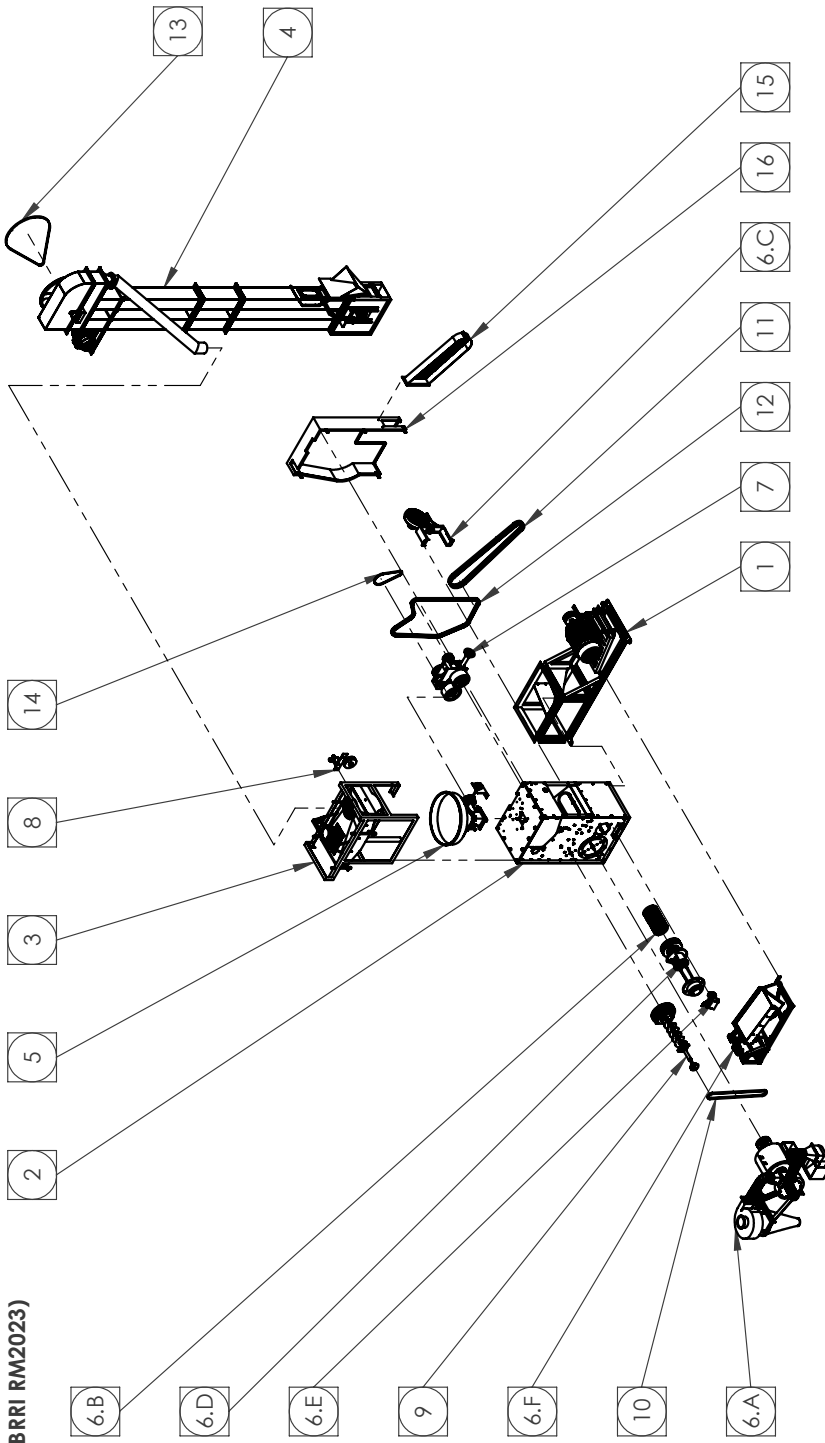

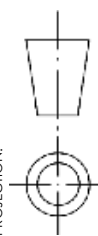
UNLESS OTHERWISE SPECIFIED: STD. TOLERANCE DIMENSIONS ARE IN MILLIMETER MILLIMETER: ±0.1, ANGULAR: ± 0.05° * DOES NOT APPLY TO HOLE SIZE				BANGLADESH RICE RESEARCH INSTITUTE SFMRA PROJECT, FMPHT DIVISION		DO NOT SCALE DRAWING FINISH: NONE FIRST ISSUED: 02-AUG-2023	
DETAILS	NAME	SIGNATURE	DATE	TITLE: BRRI COMPACT RICE MILL (BRRI RM2023)			
	ENGR. SHAFER JAHAN KHAN	S. J.K	03-DEC-2023	DRG. NAME: BRRI COMPACT RICE MILL ASSEMBLY (EXPLODED VIEW)			
CHK'D	DR. MD. MOSHARRAF HOSSAIN	M. M.H	18-DEC-2023	DWG NO: RM2023-B			
APP'VD	DR. AKM SAIBUL ISLAM	A.S.I	30-DEC-2023	MANUFACTURING METHOD: MOLDING, MACHINING, BENDING & WELDING			
THIRD ANGLE PROJECTION:							
NOTE: DEBURR AND BREAK SHARP EDGES ALL BENDS MIN. RADIUS UNLESS SPECIFIED				WEIGHT: 1199883.28 g SCALE: 1:90		SHEET: 2 REVISION: A	

BASE SUB-ASSEMBLY

ITEM NO.	DESCRIPTION	PART NO.	MATERIAL	QTY.
1	WELDMENTS FRAME BASE	RM2023_S1-001	Plain Carbon Steel	1
2	HEX NUT_M20 x 2.50 x 18	RM2023_S1-006	Stainless Steel (ferritic)	4
3	MOTOR CARRYING BED	RM2023_S1-002	Plain Carbon Steel	1
4	MOTOR CARRYING SHAFT	RM2023_S1-005	Stainless Steel (ferritic)	1
5	ELECTRIC MOTOR-256T-25HP-60Hz-3 PHASE	RM2023_S1-004	N/A	1
6	BASE MOTOR PULLEY	RM2023_S1-003	Gray Cast Iron	1
7	HUSK OUT-LINE	RM2023_S1-008	Plain Carbon Steel	1
8	MOTOR CARRYING BED PART	RM2023_S1-007	Plain Carbon Steel	2

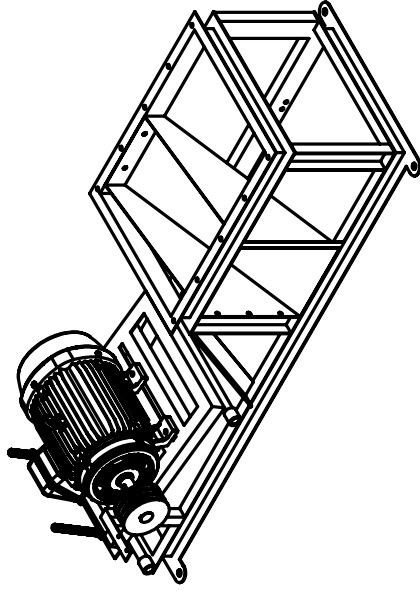

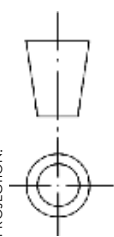
UNLESS OTHERWISE SPECIFIED: STD. TOLERANCE DIMENSIONS ARE IN MILLIMETER MILLIMETER: ±0.1, ANGULAR: ± 0.05° * DOES NOT APPLY TO HOLE SIZE				BANGLADESH RICE RESEARCH INSTITUTE SFMRA PROJECT, FMPHT DIVISION		DO NOT SCALE DRAWING	
DETAILS		NAME	SIGNATURE	DATE	FINISH: NONE		
DRAWN		ENGR. SHAFER JAHAN RHAN	S J K	01-AUG-2023	FIRST ISSUED: 02-AUG-2023		
CHK'D	DR. MD. MOSHARRAF HOSSAIN	M M H		18-OCT-2023	TITLE: BRRI COMPACT RICE MILL (BRRI RM2023)		
APP'D	DR. AKM SAIFUL ISLAM	A S I		30-OCT-2023	DRG. NAME: S-1_BASE SUB-ASSEMBLY		
THIRD ANGLE PROJECTION:							
				DWG NO: RM2023_S1-A			
				MANUFACTURING METHOD: MOLDING, MACHINING, BENDING & WELDING			
				WEIGHT: 174813.95 g			
				SCALE: 1:20			
				SHEET 3		REVISION: A	

NOTE: DEBURR AND BREAK SHARP EDGES ALL BENDS MIN. RADIUS UNLESS SPECIFIED

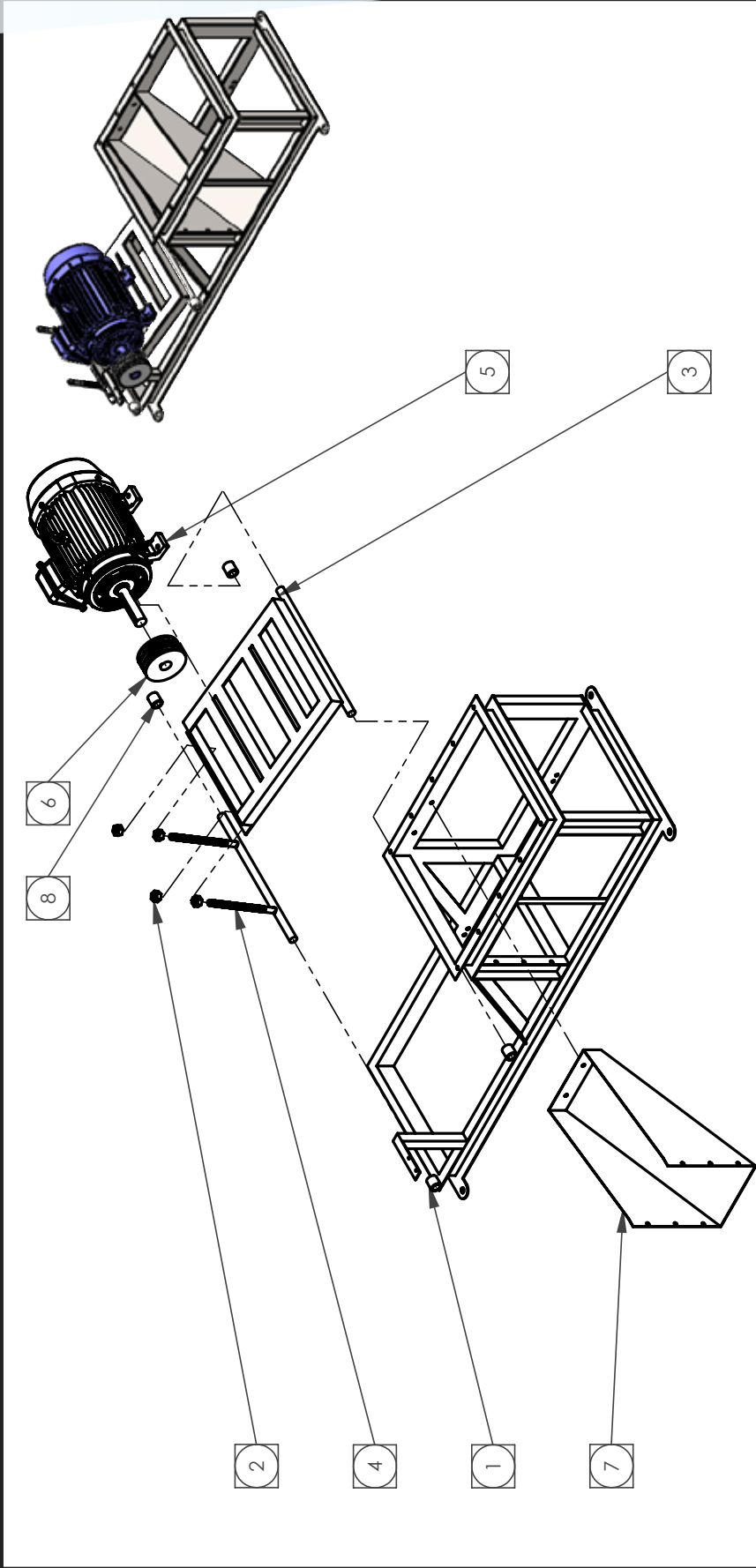

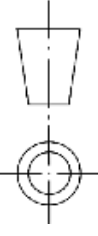
UNLESS OTHERWISE SPECIFIED: STD. TOLERANCE DIMENSIONS ARE IN MILLIMETER MILLIMETER: ±0.1, ANGULAR: ±0.05° * DOES NOT APPLY TO HOLE SIZE				BANGLADESH RICE RESEARCH INSTITUTE SFMRA PROJECT, FMPHT DIVISION		DO NOT SCALE DRAWING	
DETAILS		NAME	SIGNATURE	DATE	FINISH: NONE		
DRAWN		ENGR. SHAFER JAHAN RHAN	S. J.K	03-DEC-2023	FIRST ISSUED: 02-AUG-2023		
CHK'D		DR. MD. MOSHARRAF HOSSAIN	M. M.H	18-DEC-2023	TITLE: BRRI COMPACT RICE MILL (BRRI RM2023)		
APP'D		DR. AKM SAIBUL ISLAM	A.S.I	30-DEC-2023	DRG. NAME: S-1_BASE SUB-ASSEMBLY (EXPLODED VIEW)		
THIRD ANGLE PROJECTION:				DWG NO: RM2023_s1-B			
NOTE: DEBURR AND BREAK SHARP EDGES ALL BENDS MIN. RADIUS UNLESS SPECIFIED				MANUFACTURING METHOD: MOLDING, MACHINING, BENDING & WELDING			
				WEIGHT: 174813.95 g		A4	
				SCALE: 1:20		REVISION: A	
				SHEET 4		A	

ITEM NO.	Description	PartNo	Material	QTY.
1	UPPER HOLDING PART	RM2023_S2-009	Plain Carbon Steel	1
2	MACHINE SHELL	RM2023_S2-010	Plain Carbon Steel	1
3	RUBBER ROLLER OUTER CASING PART - 1.1	RM2023_S2-013	Plain Carbon Steel	1
4	MAIN BODY REAR CASING PART - 1	RM2023_S2-016	Plain Carbon Steel	1
5	RUBBER ROLLER OUTER CASING PART - 1.2	RM2023_S2-017	Plain Carbon Steel	1
6	LOOKING GLASS FRAME	RM2023_S2-019	ASTM A36 Steel	1
7	LOOKING GLASS	RM2023_S2-020	Glass	1
8	HUSK CONVEYER CASING	RM2023_S2-021	Plain Carbon Steel	1
9	HUSK SEPARATING AIR LINE BOX PART	RM2023_S2-022	Plain Carbon Steel	1
10	POLISHER CASING PART - 1.1	RM2023_S2-023	Plain Carbon Steel	1
11	POLISHER CASING PART - 1.2	RM2023_S2-024	Plain Carbon Steel	1
12	MAIN BODY INTERNAL PART - 1 - HUSK LINE	RM2023_S2-025	Plain Carbon Steel	1
13	INTERNAL BODY PART - 2 - HUSK LINE SUPPORT	RM2023_S2-026	Plain Carbon Steel	1
14	AIR LINE BOX PART	RM2023_S2-031	Plain Carbon Steel	1
15	INTERNAL PART - 1.3 - CONVEYER AGAR COVER	RM2023_S2-027	Plain Carbon Steel	1
16	INNER BLOWER SUPPORT PART	RM2023_S2-028	ASTM A36 Steel	1
17	POLISHER OUTER CASING PART - 1.1	RM2023_S2-018	Plain Carbon Steel	1
18	MAIN BODY REAR CASING PART - 4	RM2023_S2-033	Plain Carbon Steel	1
19	MAIN BODY REAR CASING PART - 4.1	RM2023_S2-034	Plain Carbon Steel	1
20	HUSK OUTPUT LINE PART-02	RM2023_S2-035	ASTM A36 Steel	1
21	HUSK OUTPUT LINE PART-01	RM2023_S2-036	Plain Carbon Steel	1
22	MAIN BODY REAR CASING PART - 3	RM2023_S2-032	Plain Carbon Steel	1
23	MAIN BODY SHELL FLANGE - 1	RM2023_S2-029	Plain Carbon Steel	1
24	MAIN BODY SHELL FLANGE - 2	RM2023_S2-030	Plain Carbon Steel	1
25	BODY SHELL OUTER PART	RM2023_S2-012	ASTM A36 Steel	1
26	RUBBER ROLLER INNER CASING PART - 1.1	RM2023_S2-014	Plain Carbon Steel	1
27	RUBBER ROLLER INNER CASING PART - 1.2	RM2023_S2-015	Plain Carbon Steel	1
28	RUBBER ROLLER TRAY	RM2023_S2-037	ASTM A36 Steel	1
29	POLISHER OUTER CASING lock	RM2023_S2-039	Stainless Steel (ferritic)	1
30	RUBBER ROLLER SUPPORT PART	RM2023_S2-038	Plain Carbon Steel	2
31	RUBBER ROLLER BODY GATE	RM2023_S2-011	Plain Carbon Steel	1

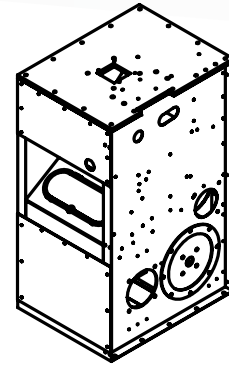

NOTE: DEBURR AND BREAK SHARP EDGES ALL BENDS MIN. RADIUS UNLESS SPECIFIED

UNLESS OTHERWISE SPECIFIED:
 STD. TOLERANCE
 DIMENSIONS ARE IN MILLIMETER
 MILLIMETER: ± 0.1
 ANGLE: ± 0.05°
 * DOES NOT APPLY TO HOLE SIZE



BANGLADESH RICE RESEARCH INSTITUTE
 SFMRA PROJECT, FMPHT DIVISION

DO NOT SCALE DRAWING

FINISH: NONE

FIRST ISSUED: 02-AUG-2023

	NAME	SIGNATURE	DATE
DRAWN	ENGR. SHAFIER JAHAN KHAN	S J K	03-DEC-2023
CHK'D	DR. MD. MOSHARRAF HOSSAIN	M M H	18-DEC-2023
APPV'D	DR. AKM SAIFUL ISLAM	A S I	30-DEC-2023

TITLE: BRRI COMPACT RICE MILL (BRRI RM2023)

DRG. NAME: S-2_MAIN BODY-SUB-ASSEMBLY

THIRD ANGLE PROJECTION:

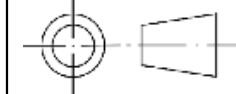

DWG NO: RM2023_S2-A

MANUFACTURING METHOD: MACHINING, BENDING & WELDING

WEIGHT: 197743.12 g

A4

SCALE: 1:30

SHEET 5

REVISION: A

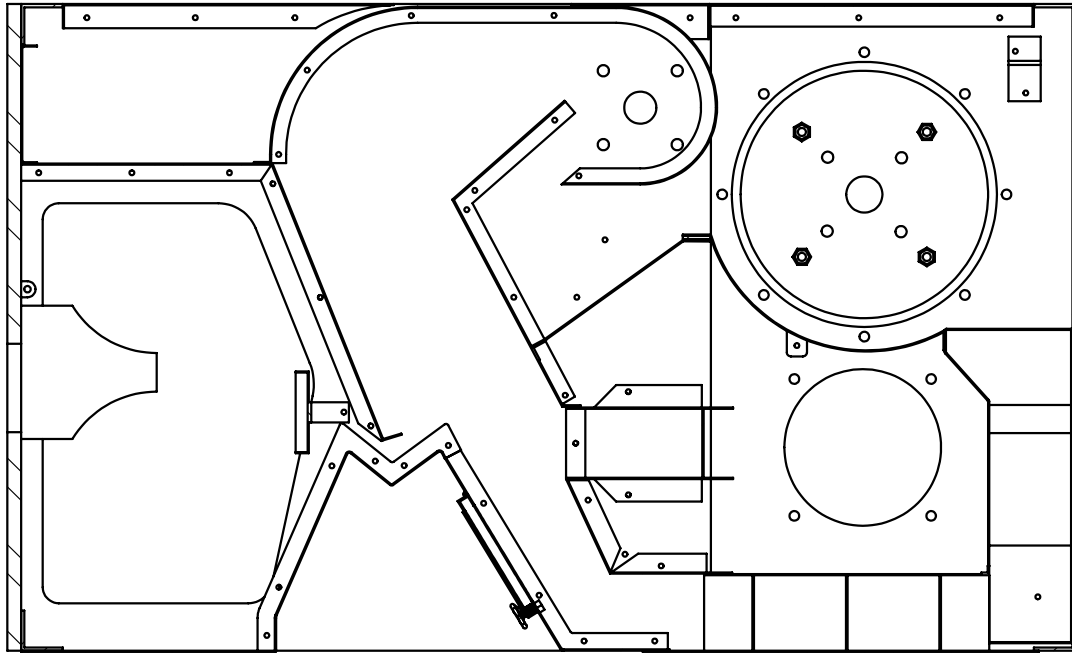
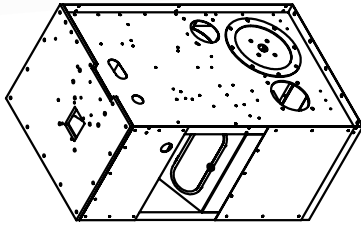

PART NO: RM2023_S2-A
SHEET - 06

N.B: BROKEN-OUT SECTION VIEW

***THIS PAGE IS PRESENTING HOW IT LOOKS AFTER ASSEMBLE ALL BODY SHEET PARTS. (BROKEN-OUT SECTION FROM RIGHT VIEW)**

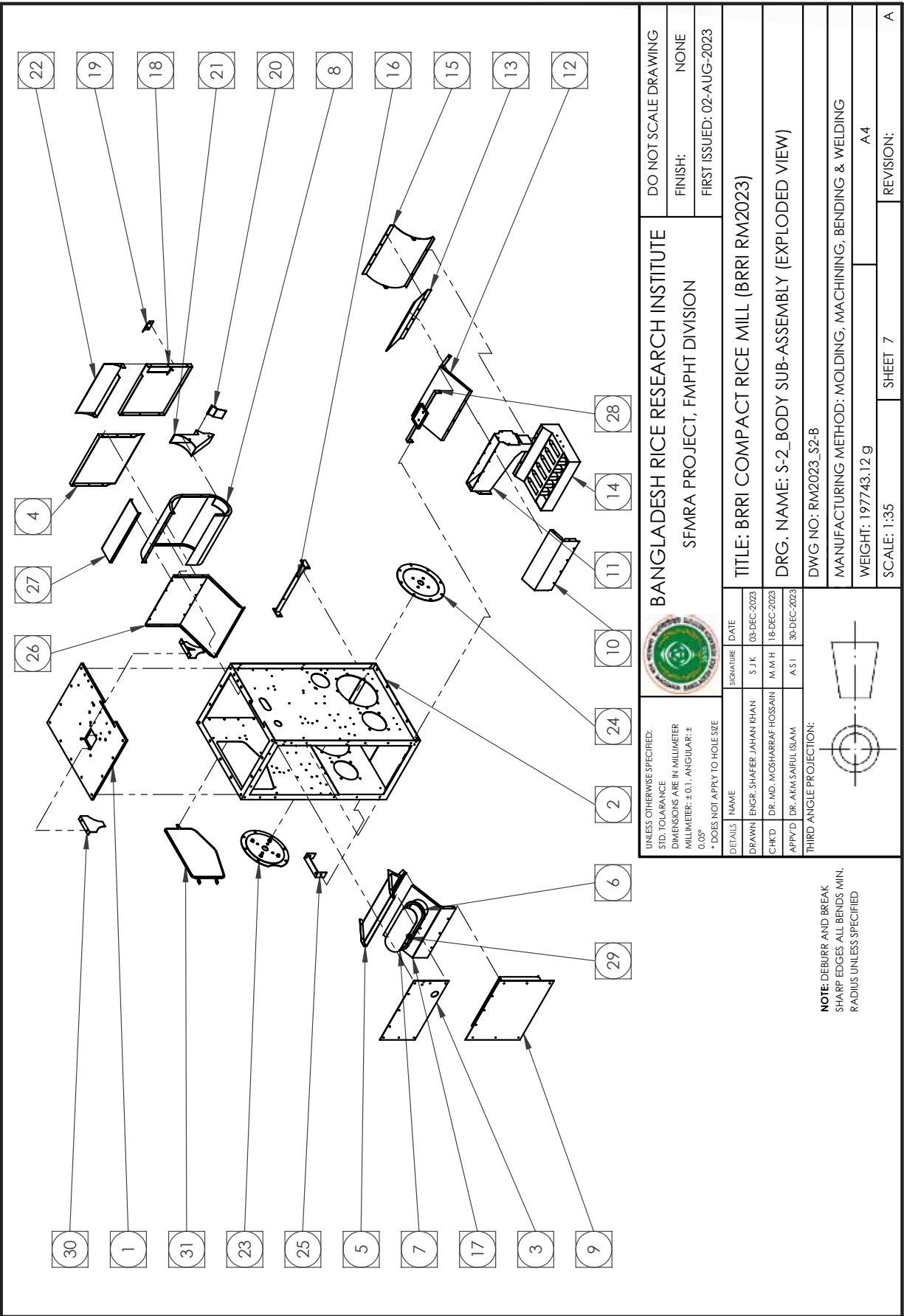

DO NOT SCALE DRAWING
 FINISH: NONE
 FIRST ISSUED: 02-AUG-2023

BANGLADESH RICE RESEARCH INSTITUTE
 SFMRA PROJECT, FMPHT DIVISION



TITLE: BRRI COMPACT RICE MILL (BRRI RM2023)

DRG. NAME: S-2_BODY SUB-ASSEMBLY (EXPLODED VIEW)

DWG NO: RM2023_S2-B

MANUFACTURING METHOD: MOLDING, MACHINING, BENDING & WELDING

WEIGHT: 197743.12 g

SCALE: 1:35

SHEET 7

REVISION: A

UNLESS OTHERWISE SPECIFIED:
 STD. TOLERANCE
 DIMENSIONS ARE IN MILLIMETER
 MILLIMETER: ±0.1, ANGULAR: ±
 0.05°
 * DOES NOT APPLY TO HOLE SIZE

DETAILS	NAME	SIGNATURE	DATE
DRAWN	ENGR. SHAFER JAHAN RHAN	S J K	03-DEC-2023
CHK'D	DR. MD. MOSHARRAF HOSSAIN	M M H	18-DEC-2023
APP'VD	DR. AKM SAIBUL ISLAM	A S I	30-DEC-2023

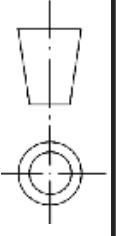

NOTE: DEBURR AND BREAK
 SHARP EDGES ALL BENDS MIN.
 RADIUS UNLESS SPECIFIED

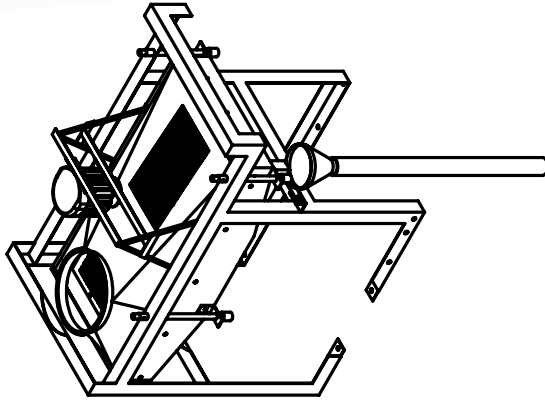

MODEL: NET FRAME CHALUNI

ITEM NO.	Description	PartNo	Material	QTY.
1	NET FRAME CHALUNI WELDMENTS BODY FRAME	RM2023_S3-41	Plain Carbon Steel	1
2	ROPE	RM2023_S3-51	Polyester Resin	1
3	CHALUNI BODY CASING	RM2023_S3-47	Plain Carbon Steel	1
4	METAL MESH NET	RM2023_S3-50	Plain Carbon Steel	1
5	CHALUNI BODY PART - 1	RM2023_S3-49	Plain Carbon Steel	1
6	CLEAN PADDY OUTPUT GATE PART	RM2023_S3-53	Plain Carbon Steel	1
7	TOP COVER	RM2023_S3-48	Plain Carbon Steel	1
8	NET FRAME-MOTOR 1 HP	RM2023_S3-42	Gray Cast Iron	1
9	CAM	RM2023_S3-44	Plain Carbon Steel	1
10	CAM ADJUSTING PART	RM2023_S3-43	Plain Carbon Steel	1
11	CHALUNI SUPPORT PART	RM2023_S3-46	Plain Carbon Steel	2
12	CHALUNI-NET SUPPORT FRAME	RM2023_S3-45	Plain Carbon Steel	1
13	M10 BOLTS	N/A	STAINLESS STEEL	3
14	M10 NUT	N/A	STAINLESS STEEL	1
15	PRE-CLEANER MOTOR CARRIER	RM2023_S3-42	Plain Carbon Steel	1
16	IMPURITIES DRAIN LINE	RM2023_S3-54	Plain Carbon Steel	1
17	HOSE PIPE 50MM INNER DIA	RM2023_S3-52	Custom Plastic	1

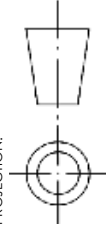
		BANGLADESH RICE RESEARCH INSTITUTE SFMRA PROJECT, FMPHT DIVISION		DO NOT SCALE DRAWING	
		TITLE: BRRI COMPACT RICE MILL (BRRI RM2023)		FINISH: NONE	
UNLESS OTHERWISE SPECIFIED: STD. TOLERANCE DIMENSIONS ARE IN MILLIMETER MILLIMETER: ±0.1, ANGULAR: ± 0.05° * DOES NOT APPLY TO HOLE SIZE		DETAILS NAME DRAWN ENGR. SHAFER JAHAN KHAN CHK'D DR. MD. MOSHARRAF HOSSAIN APP'VD DR. AKM SAIBUL ISLAM	SIGNATURE S J K M M H A S I	DATE 03-DEC-2023 18-DEC-2023 30-DEC-2023	FIRST ISSUED: 02-AUG-2023
THIRD ANGLE PROJECTION: 		DRG. NAME: S-3_PRECLEANER_SUB-ASSEMBLY DWG NO: RM2023_S2_S3-A			
NOTE: DEBURR AND BREAK SHARP EDGES ALL BENDS MIN. RADIUS UNLESS SPECIFIED		MANUFACTURING METHOD: MOLDING, MACHINING, BENDING & WELDING WEIGHT: 103003.24 g SCALE: 1:20		SHEET 8 REVISION: A	

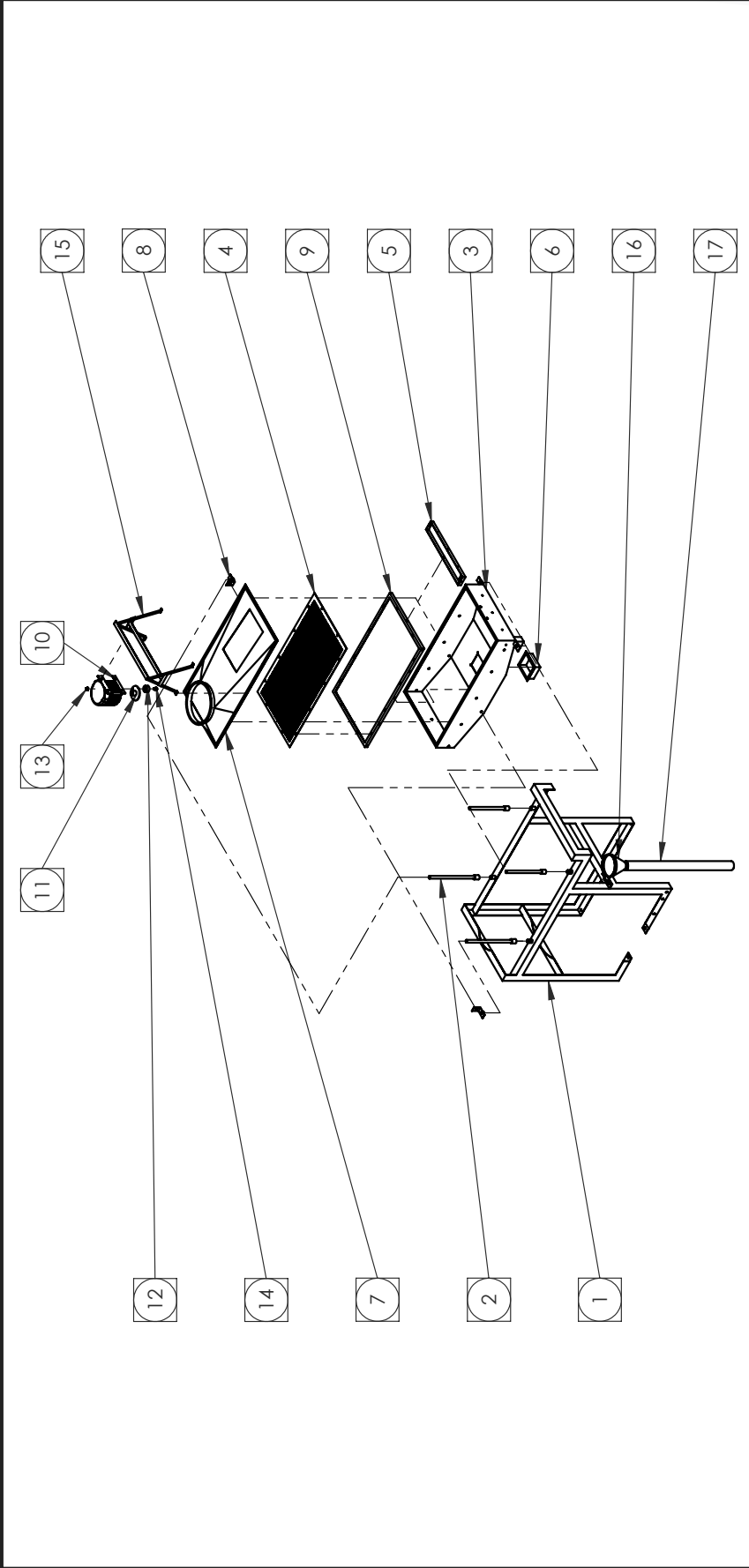

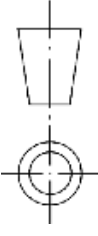
UNLESS OTHERWISE SPECIFIED: STD. TOLERANCE DIMENSIONS ARE IN MILLIMETER MILLIMETER: ±0.1, ANGULAR: ± 0.05° * DOES NOT APPLY TO HOLE SIZE				BANGLADESH RICE RESEARCH INSTITUTE SFMRA PROJECT, FMPHT DIVISION		DO NOT SCALE DRAWING	
DETAILS		NAME	SIGNATURE	DATE	FINISH: NONE		
DRAWN		ENGR. SHAFER JAHAN RHAN	S. J.K	03-DEC-2023	FIRST ISSUED: 02-AUG-2023		
CHK'D		DR. MD. MOSHARRAF HOSSAIN	M. M.H	18-DEC-2023	TITLE: BRRI COMPACT RICE MILL (BRRI RM2023)		
APP'D		DR. AKM SAIBUL ISLAM	A.S.I	30-DEC-2023	DRG. NAME: S-3_PRE-CLEANER_SUB-ASSEMBLY (EXPLODED VIEW)		
THIRD ANGLE PROJECTION:				DWG NO: RM2023_S2_S3-B			
NOTE: DEBURR AND BREAK SHARP EDGES ALL BENDS MIN. RADIUS UNLESS SPECIFIED		MANUFACTURING METHOD: MOLDING, MACHINING, BENDING & WELDING		WEIGHT: 103002.03 g			
		SCALE: 1:35		SHEET 9		REVISION: A	

ITEM NO.	DESCRIPTION	PartNo	Material	QTY.
1	BOTTOM CASING	RM2023_S4-79	Plain Carbon Steel	1
2	BTM-C-ANGLE BAR	RM2023_S4-83	ASTM A36 Steel	4
3	BTM-C-ANGLE BAR 2	RM2023_S4-84	ASTM A36 Steel	4
4	HEIGHT CONTROLLER PART	RM2023_S4-80	Plain Carbon Steel	2
5	BOTTOM PULLEY SHAFT	RM2023_S4-81	Plain Carbon Steel	1
6	PULLEY PART - BOTTOM	RM2023_S4-78	ASTM A36 Steel	1
7	BTM-CONTROL GATE	RM2023_S4-84	Plain Carbon Steel	2
8	BPHC- NUT	RM2023_S4-80	Stainless Steel (ferritic)	2
9	BOTTOM HOPPER	RM2023_S4-76	Plain Carbon Steel	1
10	HOPPER GATE CONTROLLER	RM2023_S4-85	ASTM A36 Steel	1
11	FLANGE PART	RM2023_S4-53	ASTM A36 Steel	6
12	BD-2-BODY	RM2023_S4-58	ASTM A36 Steel	1
13	BD-1-BODY	RM2023_S4-55	Plain Carbon Steel	3
14	TOP PULLEY HOLDING PART	RM2023_S4-70	Plain Carbon Steel	1
15	UCP207 - ISB	RM2023_S4-67	Gray Cast Iron	2
16	PADDY CONVEYER PIPE PART	RM2023_S4-72	ASTM A36 Steel	1
17	PULLEY LOCK BOLT	RM2023_S4-63	Stainless Steel (ferritic)	2
18	TOP COVER	RM2023_S4-64	Plain Carbon Steel	1
19	MOTOR CASE PART- 1.3	RM2023_S4-61	ASTM A36 Steel	3
20	MOTOR CASE PART- 1.2	RM2023_S4-60	ASTM A36 Steel	2
21	ELEVATOR TOP PULLEY	RM2023_S4-75	Plain Carbon Steel	1
22	BD-2-DOOR	RM2023_S4-57	ASTM A36 Steel	1
23	BD-2-GLASS PART	RM2023_S4-56	Glass	1
24	ELEVATOR FLAT BELT	RM2023_S4-74	POLYURETHANE (11671)	1
25	PADDY TRANSFER LINE	RM2023_S4-87	ASTM A36 Steel	1
26	ELEVATOR BODY - 1	RM2023_S4-53	Plain Carbon Steel	2
27	MOTOR CASE PART-1.1	RM2023_S4-59	ASTM A36 Steel	1
28	MOTOR PULLEY-SMALL	RM2023_S4-62	Plain Carbon Steel	1
29	ELEVATOR MOTOR 3 HP	RM2023_S4-73	Gray Cast Iron	1
30	PADDY TRANSFER LINE-FLANGE	RM2023_S4-87	ASTM A36 Steel	1
31	HANDLE - 1	RM2023_S4-79	PLAIN CARBON STEEL	1
32	BOLT	N/A	SS	1
33	HANDLE - 2	RM2023_S4-72	PLAIN CARBON STEEL	1
34	HANDLE - 3	RM2023_S4-79	PLAIN CARBON STEEL	1
35	TOP CONTROL PART - 1	RM2023_S4-65	ASTM A36 Steel	1
36	TOP CONTROL PART - 2	RM2023_S4-69	ASTM A36 Steel	1
37	UCP 207	RM2023_S4-77		2
38	PULLEY SHAFT-TOP	RM2023_S4-68	ASTM A36 Steel	1
39	FLAT BELT PULLEY	RM2023_S4-65	ASTM A36 Steel	1
40	PADDY CONVEYER PIPE PART-1	RM2023_S4-87	ASTM A36 Steel	1
41	ELEVATOR BUCKET	RM2023_S4-74	Plain Carbon Steel	48

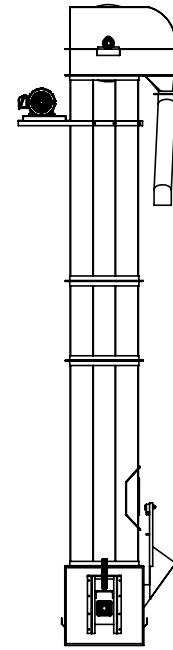

ELEVATOR

NOTE: DEBURR AND BREAK SHARP EDGES ALL BENDS MIN. RADIUS UNLESS SPECIFIED

UNLESS OTHERWISE SPECIFIED:
 DIMENSIONS ARE IN MILLIMETER
 MILLIMETER: ± 0.1
 ANGULAR: ± 0.05°
 * DOES NOT APPLY TO HOLE SIZE



BANGLADESH RICE RESEARCH INSTITUTE

SFMRA PROJECT, FMPPT DIVISION

DO NOT SCALE DRAWING

FINISH: NONE

FIRST ISSUED: 02-AUG-2023

NAME	SIGNATURE	DATE	TITLE: BRRI COMPACT RICE MILL (BRRI RM2023)	
DRAWN ENGR. SHAFIER JAHAN KHAN	S J K	18-AUG-2023	DRG. NAME: S-4_ELEVATOR_SUB-ASSEMBLY	
CHK'D DR. MD. MOSHARRAF HOSSAIN	M M H	18-DEC-2023	DWG NO: RM2023_S4-A	
APPV'D DR. AKM SAIFUL ISLAM	A S I	30-DEC-2023	MANUFACTURING METHOD: MACHINING, BENDING & WELDING	
THIRD ANGLE PROJECTION:			WEIGHT: 317866.03 g	
			A4	
			SCALE: 1:50	SHEET 10

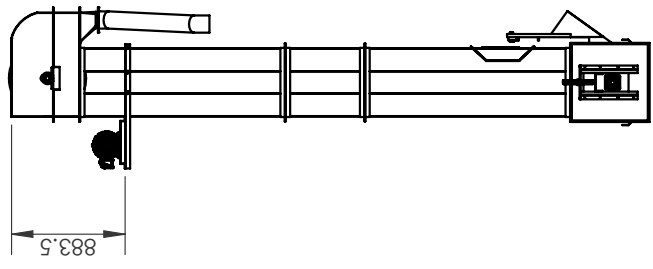
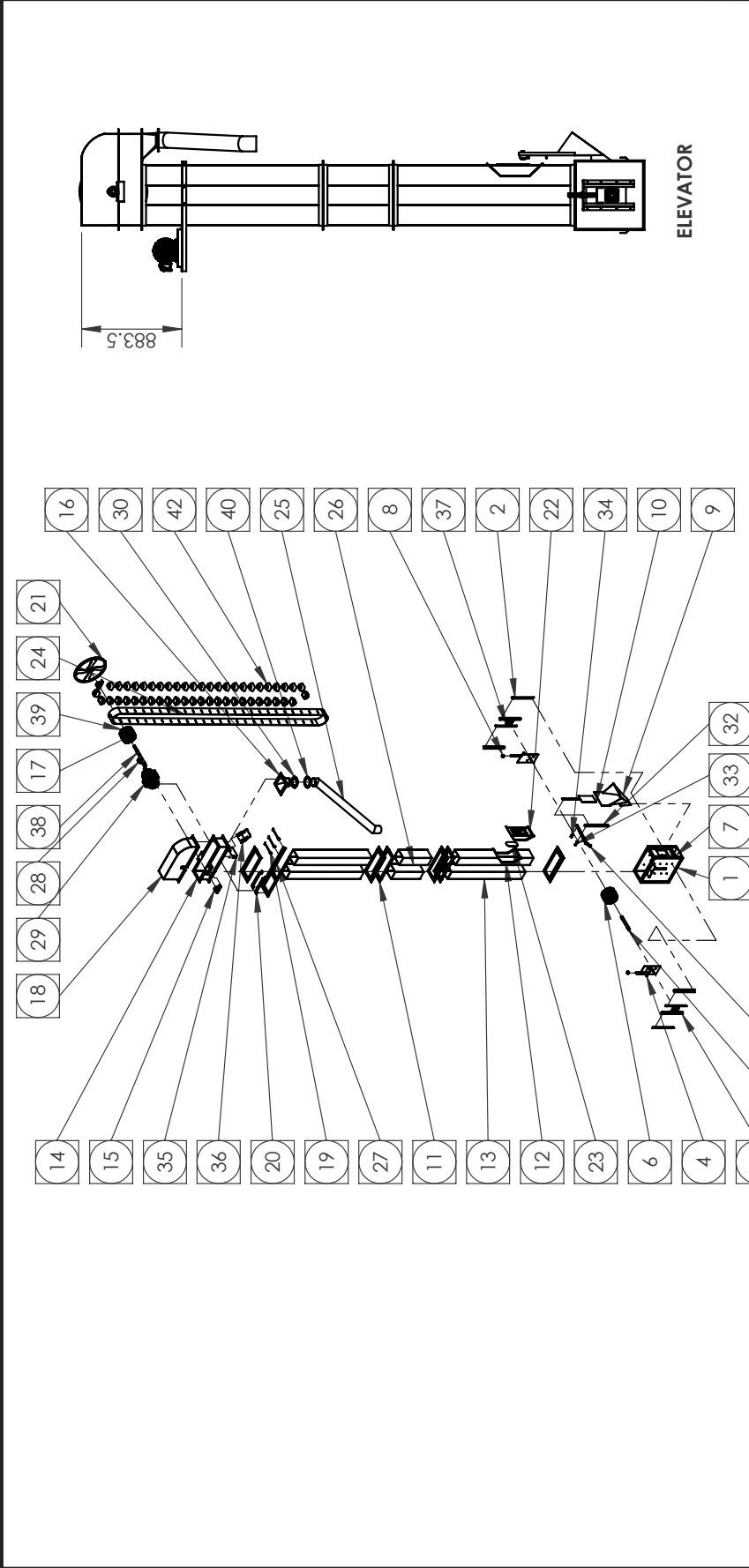

ELEVATOR

<p>UNLESS OTHERWISE SPECIFIED: STD. TOLERANCE DIMENSIONS ARE IN MILLIMETER MILLIMETER: ±0.1, ANGULAR: ± 0.05° * DOES NOT APPLY TO HOLE SIZE</p>		<p>DATE: 03-DEC-2023 SIGNATURE: S.J.K. DRAWN: ENGR. SHAFER JAHAN RHAN CHK'D: DR. MD. MOSHARRAF HOSSAIN APP'D: DR. AKM SAIBUL ISLAM</p>		<p>DATE: 18-DEC-2023 SIGNATURE: M.M.H. DATE: 30-DEC-2023 SIGNATURE: A.S.I.</p>		<p>DO NOT SCALE DRAWING</p>	
<p>BANGLADESH RICE RESEARCH INSTITUTE SFMRA PROJECT, FMPHT DIVISION</p>				<p>FINISH: NONE</p>		<p>FIRST ISSUED: 02-AUG-2023</p>	
<p>TITLE: BRRI COMPACT RICE MILL (BRRI RM2023)</p>							
<p>DRG. NAME: S-4_ELEVATOR_SUB-ASSEMBLY (EXPLODED VIEW)</p>							
<p>DWG NO: RM2023_S4-B</p>							
<p>MANUFACTURING METHOD: MOLDING, MACHINING, BENDING & WELDING</p>							
<p>WEIGHT: 319203.24 g</p>						<p>A4</p>	
<p>SCALE: 1:100</p>						<p>SHEET 11</p>	
<p>REVISION: A</p>							

NOTE: DEBURR AND BREAK SHARP EDGES ALL BENDS MIN. RADIUS UNLESS SPECIFIED

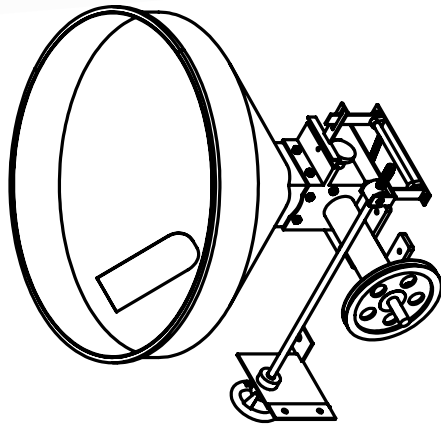

HOPPER

ITEM NO.	Description	PartNo	Material	QTY.
1	PADDY HOPPER BODY PART	RM2023_S5-88	Plain Carbon Steel	1
2	THREAD KEY	RM2023_S5-95	ASTM A36 Steel	1
3	PADDY HOPPER CASING	RM2023_S5-90	Plain Carbon Steel	1
4	PADDY HOPPER CASING RING	RM2023_S5-91	Plain Carbon Steel	1
5	HOPPER GATE CONTROLLER PART	RM2023_S5-93	ASTM A36 Steel	1
6	20x35x9-2RS Rubber Sealed Ball Bearing	RM2023_S5-98	Chrome Stainless Steel	2
7	DELIVERY CONTROLLER SHELL - SHAFT	RM2023_S5-99	ASTM A36 Steel	1
8	DELIVERY CONTROLLER SHELL	RM2023_S5-96	ASTM A36 Steel	1
9	IN DELIVERY CONTROLLER SHELL - CASE	RM2023_S5-97	ASTM A36 Steel	1
10	HOPPER PULLEY	RM2023_S5-89	Plain Carbon Steel	1
11	HOPPER-SPRING	RM2023_S5-93	Tungsten	1
12	M8 BOLTS	N/A	STAINLESS STEEL (SS)	10
13	M7 BOLT LONG 30mm	RM2023_S5-100	Stainless Steel (ferritic)	2
14	M7 BOLT LONG 30mm	RM2023_S5-103	Plain Carbon Steel	1
15	HOPPER - GAP CONTROLLER DEVICE (MANUAL)	RM2023_S5-104	ASTM A36 Steel	1
16	HOPPER - GAP CONTROLLER LOCK	RM2023_S5-105	Plain Carbon Steel	1
17	HOPPER - GAP CONTROLLER SUPPORT LOCK	RM2023_S5-106	Plain Carbon Steel	1
18	HOPPER - GAP CONTROLLER BASE SUPPORT	RM2023_S5-108	Plain Carbon Steel	1
19	M7 BOLT LONG 30mm	RM2023_S5-102	Plain Carbon Steel	1
20	PADDY HOPPER CASING	RM2023_S5-90	Plain Carbon Steel	1
21	GAP CONTROLLER PART	RM2023_S5-94	Plain Carbon Steel	1

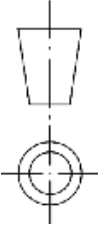
		BANGLADESH RICE RESEARCH INSTITUTE SFMRA PROJECT, FMPHT DIVISION		DO NOT SCALE DRAWING
		TITLE: BRRI COMPACT RICE MILL (BRRI RM2023)		FINISH: NONE
UNLESS OTHERWISE SPECIFIED: STD. TOLERANCE DIMENSIONS ARE IN MILLIMETER MILLIMETER: ±0.1, ANGULAR: ± 0.05° * DOES NOT APPLY TO HOLE SIZE		SIGNATURE S J K	DATE 03-DEC-2023	FIRST ISSUED: 02-AUG-2023
DRAWN ENGR. SHAFER JAHAN KHAN CHK'D DR. MD. MOSHARRAF HOSSAIN APP'VD DR. AKM SAIBUL ISLAM		M M H A S I	18-DEC-2023 30-DEC-2023	
THIRD ANGLE PROJECTION: 		DRG. NAME: S-5_HOPPER SUB-ASSEMBLY (EXPLODED VIEW)		
		DWG NO: RM2023_S5-A		
NOTE: DEBURR AND BREAK SHARP EDGES ALL BENDS MIN. RADIUS UNLESS SPECIFIED		MANUFACTURING METHOD: MOLDING, MACHINING, BENDING & WELDING		
		WEIGHT: 22893.00 g SCALE: 1:12		REVISION: A
		SHEET 12		

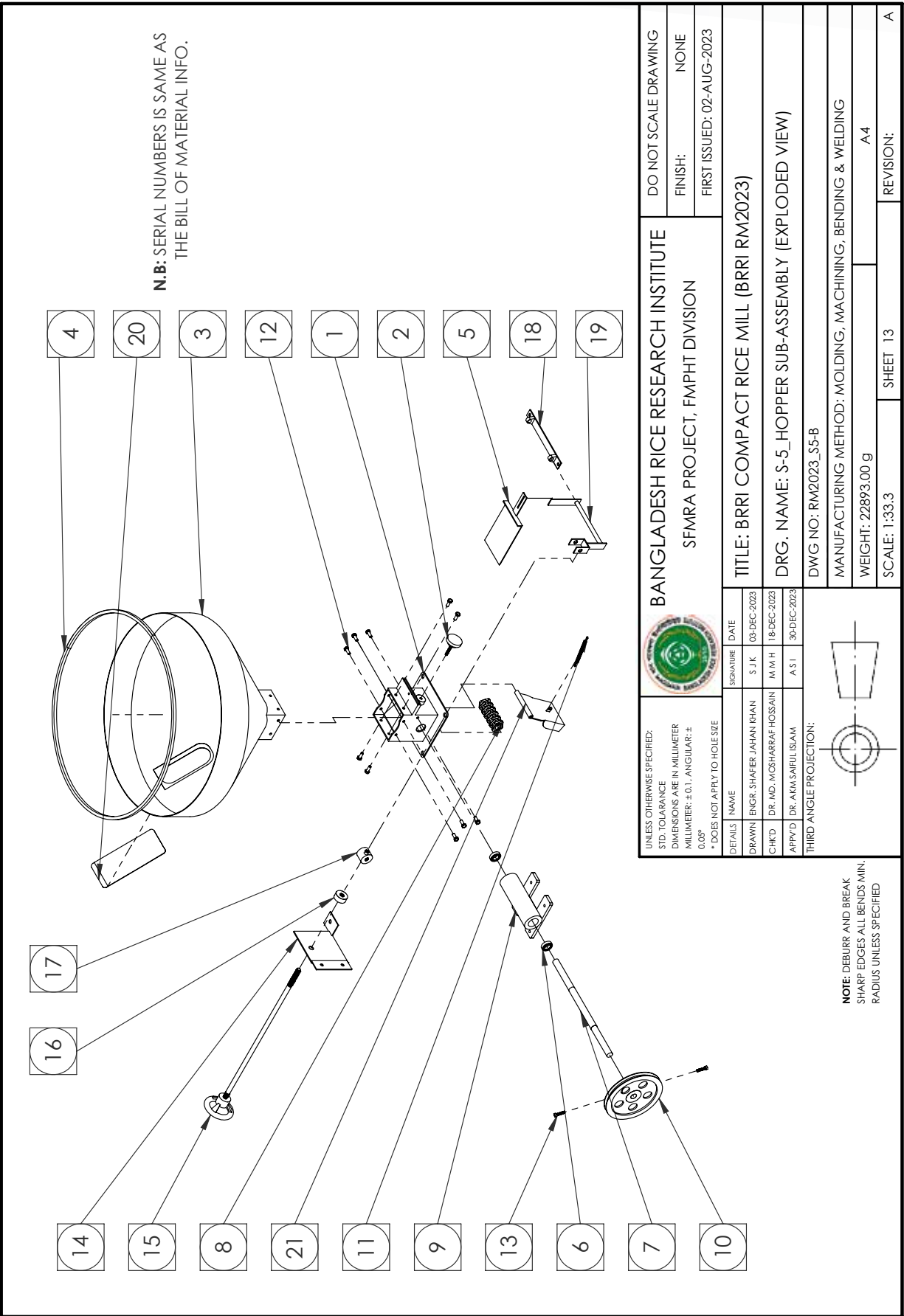

N.B: SERIAL NUMBERS IS SAME AS THE BILL OF MATERIAL INFO.

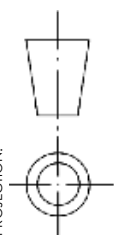

UNLESS OTHERWISE SPECIFIED: STD. TOLERANCE DIMENSIONS ARE IN MILLIMETER MILLIMETER: ±0.1, ANGULAR: ± 0.05° * DOES NOT APPLY TO HOLE SIZE				BANGLADESH RICE RESEARCH INSTITUTE SFMRA PROJECT, FMPHT DIVISION		DO NOT SCALE DRAWING	
DETAILS		NAME	SIGNATURE	DATE	FINISH: NONE		
DRAWN		ENGR. SHAFER JAHAN KHAN	S J K	03-DEC-2023	FIRST ISSUED: 02-AUG-2023		
CHK'D		DR. MD. MOSHARRAF HOSSAIN	M M H	18-DEC-2023	TITLE: BRRI COMPACT RICE MILL (BRRI RM2023)		
APP'D		DR. AKM SAIBUL ISLAM	A S I	30-DEC-2023	DRG. NAME: S-5_HOPPER SUB-ASSEMBLY (EXPLODED VIEW)		
THIRD ANGLE PROJECTION:							
				DWG NO: RM2023_S5-B			
MANUFACTURING METHOD: MOLDING, MACHINING, BENDING & WELDING							
WEIGHT: 22893.00 g				SCALE: 1:33.3			
SHEET: 13				REVISION: A			

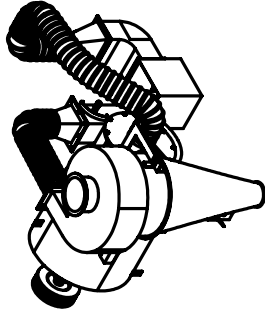
NOTE: DEBURR AND BREAK SHARP EDGES ALL BENDS MIN. RADIUS UNLESS SPECIFIED



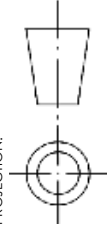

CONVEYER HOUSING BLOWER

ITEM NO.	DESCRIPTION	PartNo	MATERIAL	QTY.
1	CONVEYER BLOWER SHAFT	RM2023_S-6-A-124	ASTM A36 Steel	1
2	CONVEYER BLOWER FAN PART	RM2023_S-6-A-125	ASTM A36 Steel	1
3	HUSK SEPARATOR BLOWER FAN	RM2023_S-6-A-114	Plain Carbon Steel	1
4	SQUARE BRACKET BEARING 35MM UCF207	RM2023_S-9-124	ASTM A36 Steel	2
5	HUSK SEPARATING BLOWER - 2	RM2023_S-6-A-123	Plain Carbon Steel	1
6	INNER BLOWER FLANGE PART	RM2023_S-6-A-122	Plain Carbon Steel	2
7	MINI CONVEYER BLOWER FAN	RM2023_S-6-A-111	Plain Carbon Steel	1
8	OUTER MINI BLOWER FLANGE PART - 1.1	RM2023_S-6-A-109	Plain Carbon Steel	1
9	MACHINE BODY RICE OUTPUT SIDE PART - 1.1	RM2023_S-6-A-130	Plain Carbon Steel	1
10	HUSK SEPARATOR BLOWER PULLEY	RM2023_S-6-A-128	Plain Carbon Steel	1
11	CONVEYER BLOWER SHAFT-PULLEY JAM NUT-1	RM2023_S-6-A-112	Plain Carbon Steel	1
12	PULLEY LOCK PART-10mm x 3.8mm	RM2023_S-6-A-129	Plain Carbon Steel	1
13	M6 BOLT	N/A	SS	30
14	HUSK SEPARATING BLOWER - 1 - FLANGE - 2	RM2023_S-6-A-131	Plain Carbon Steel	1
15	HUSK SEPARATING BLOWER - 1 - FLANGE - 1	RM2023_S-6-A-132	Plain Carbon Steel	1
16	HUSK SEPARATING BLOWER - 1	RM2023_S-6-A-114	Plain Carbon Steel	1
17	HUSK SEPARATING BLOWER - 1 - FLANGE - 1	RM2023_S-6-A-115	Plain Carbon Steel	1
18	HOSE PIPE - 1	RM2023_S-6-A-116	Natural Rubber	1
19	CYCLONE FLANGE	RM2023_S-6-A-117	Plain Carbon Steel	1
20	CYCLONE SEPARATOR PART - 1	RM2023_S-6-A-118	Plain Carbon Steel	1
21	CYCLONE WELDMENTS FRAME	RM2023_S-6-A-119	Plain Carbon Steel	1
22	HOSE PIPE - 2	RM2023_S-6-A-120	Natural Rubber	1
23	MINI BLOWER CONTROL KEY PART	RM2023_S-6-A-110	Plain Carbon Steel	1

		BANGLADESH RICE RESEARCH INSTITUTE SFMRA PROJECT, FMPHT DIVISION		DO NOT SCALE DRAWING
		TITLE: BRRI COMPACT RICE MILL (BRRI RM2023)		FINISH: NONE FIRST ISSUED: 02-AUG-2023
UNLESS OTHERWISE SPECIFIED: STD. TOLERANCE DIMENSIONS ARE IN MILLIMETER MILLIMETER: ±0.1, ANGULAR: ± 0.05° * DOES NOT APPLY TO HOLE SIZE		SIGNATURE S J K	DATE 03-DEC-2023	
DRAWN ENGR. SHAFER JAHAN KHAN		M M H	18-DEC-2023	
CHK'D DR. MD. MOSHARRAF HOSSAIN		A S I	30-DEC-2023	
APP'VD DR. AKM SAIBUL ISLAM		THIRD ANGLE PROJECTION:		
				
NOTE: DEBURR AND BREAK SHARP EDGES ALL BENDS MIN. RADIUS UNLESS SPECIFIED				
DRG. NAME: S-6-A_ CONVEYER BLOWER SUB-ASSEMBLY			DWG NO: RM2023_S-6-A-A	
MANUFACTURING METHOD: MOLDING, MACHINING, BENDING & WELDING				
WEIGHT: 79781.93 g			A4	
SCALE: 1:25			SHEET 14	
			REVISION: A	

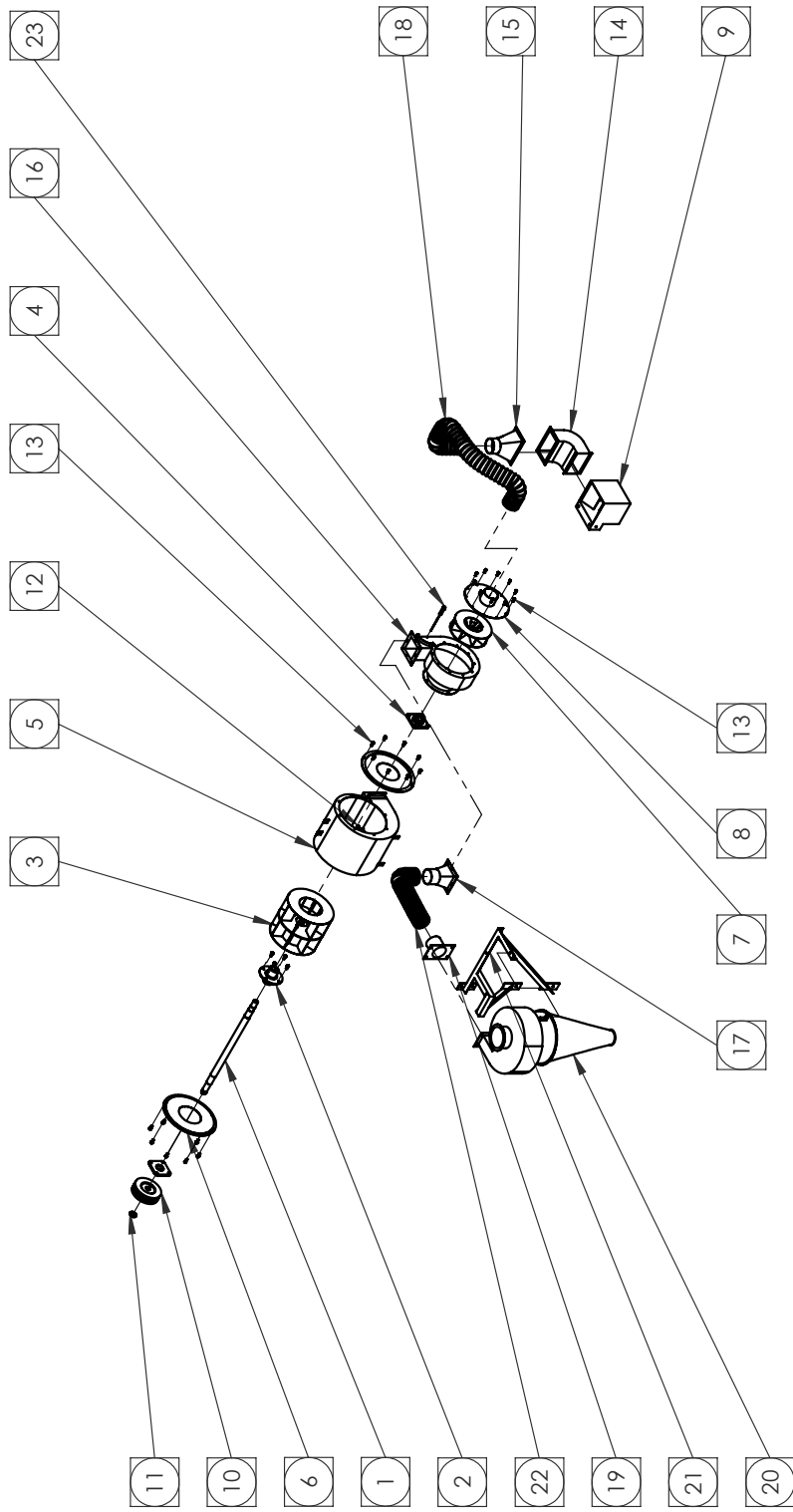
CONVEYER HOUSING BLOWER



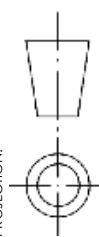

		BANGLADESH RICE RESEARCH INSTITUTE SFMRA PROJECT, FMPHT DIVISION		DO NOT SCALE DRAWING
		TITLE: BRRI COMPACT RICE MILL (BRRI RM2023)		FINISH: NONE
UNLESS OTHERWISE SPECIFIED: STD. TOLERANCE DIMENSIONS ARE IN MILLIMETER MILLIMETER: ±0.1, ANGULAR: ± 0.05° * DOES NOT APPLY TO HOLE SIZE		DETAILS NAME SIGNATURE DATE DRAWN ENGR. SHAFER JAHAN RHAN S.J.K 03-DEC-2023 CHK'D DR. MD. MOSHARRAF HOSSAIN M.M.H 18-DEC-2023 APP'VD DR. AKM SAIBUL ISLAM A.S.I 30-DEC-2023	FIRST ISSUED: 02-AUG-2023	
DRG. NAME: S-6.A. CONVEYER BLOWER SUB-ASSEMBLY (EXPLODED VIEW)		DWG NO: RM2023_S-6.A-B		
THIRD ANGLE PROJECTION: 		MANUFACTURING METHOD: MOLDING, MACHINING, BENDING & WELDING		
WEIGHT: 79781.93 g		SCALE: 1:40		SHEET 15
REVISION: A				REVISION: A

NOTE: DEBURR AND BREAK SHARP EDGES ALL BENDS MIN. RADIUS UNLESS SPECIFIED

POLISHER

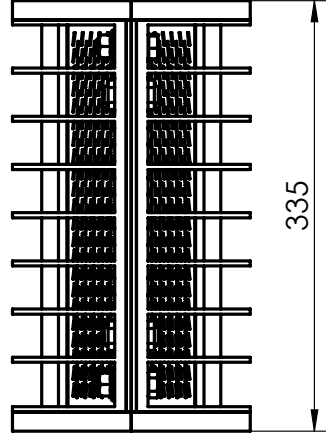
ITEM NO.	Description	PartNo	MATERIAL	QTY.
1	POLISHER HOUSING SUPPORT PART-1	RM2023_S-6-B-134	Plain Carbon Steel	4
2	POLISHER HOUSING SUPPORT PART-2	RM2023_S-6-B-135	Plain Carbon Steel	2
3	POLISHER HOUSING SUPPORT PART-3	RM2023_S-6-B-136	Plain Carbon Steel	2
4	POLISHER HOUSING PART	RM2023_S-6-B-133	Plain Carbon Steel	2
5	POLISHER-SIEVE	RM2023_S-6-B-137	Stainless Steel (ferritic)	2
6	POLISHER HOUSING SUPPORT PART-4	RM2023_S-6-B-138	ASTM A36 Steel	4
7	12mm DIA SCREW BOLTS	N/A	STAINLESS STEEL	8
8	12mm DIA SCREW NUTS	N/A	STAINLESS STEEL	8
9	M12 BOLTS	N/A	STAINLESS STEEL	4
10	M12 NUTS	N/A	STAINLESS STEEL	4

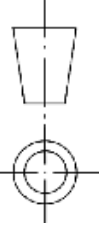

		BANGLADESH RICE RESEARCH INSTITUTE SFMRA PROJECT, FMPHT DIVISION		DO NOT SCALE DRAWING
				FINISH: NONE
UNLESS OTHERWISE SPECIFIED: STD. TOLERANCE DIMENSIONS ARE IN MILLIMETER MILLIMETER: ±0.1, ANGULAR: ± 0.05° * DOES NOT APPLY TO HOLE SIZE				FIRST ISSUED: 02-AUG-2023
DETAILS	NAME	SIGNATURE	DATE	
DRAWN	ENGR. SHAFER JAHAN RHAN	S J K	03-DEC-2023	
CHK'D	DR. MD. MOSHARRAF HOSSAIN	M M H	18-DEC-2023	
APP'VD	DR. AKM SAIBUL ISLAM	A S I	30-DEC-2023	
THIRD ANGLE PROJECTION: 				
TITLE: BRRI COMPACT RICE MILL (BRRI RM2023)				
DRG. NAME: S-6-B_ POLISHER SUB-ASSEMBLY				
DWG NO: RM2023_S-6-B-A				
MANUFACTURING METHOD: MOLDING, MACHINING, BENDING & WELDING				
WEIGHT: 14417.99 g				A4
SCALE: 1:5				REVISION: A
SHEET 16				

NOTE: DEBURR AND BREAK SHARP EDGES ALL BENDS MIN. RADIUS UNLESS SPECIFIED

POLISHER

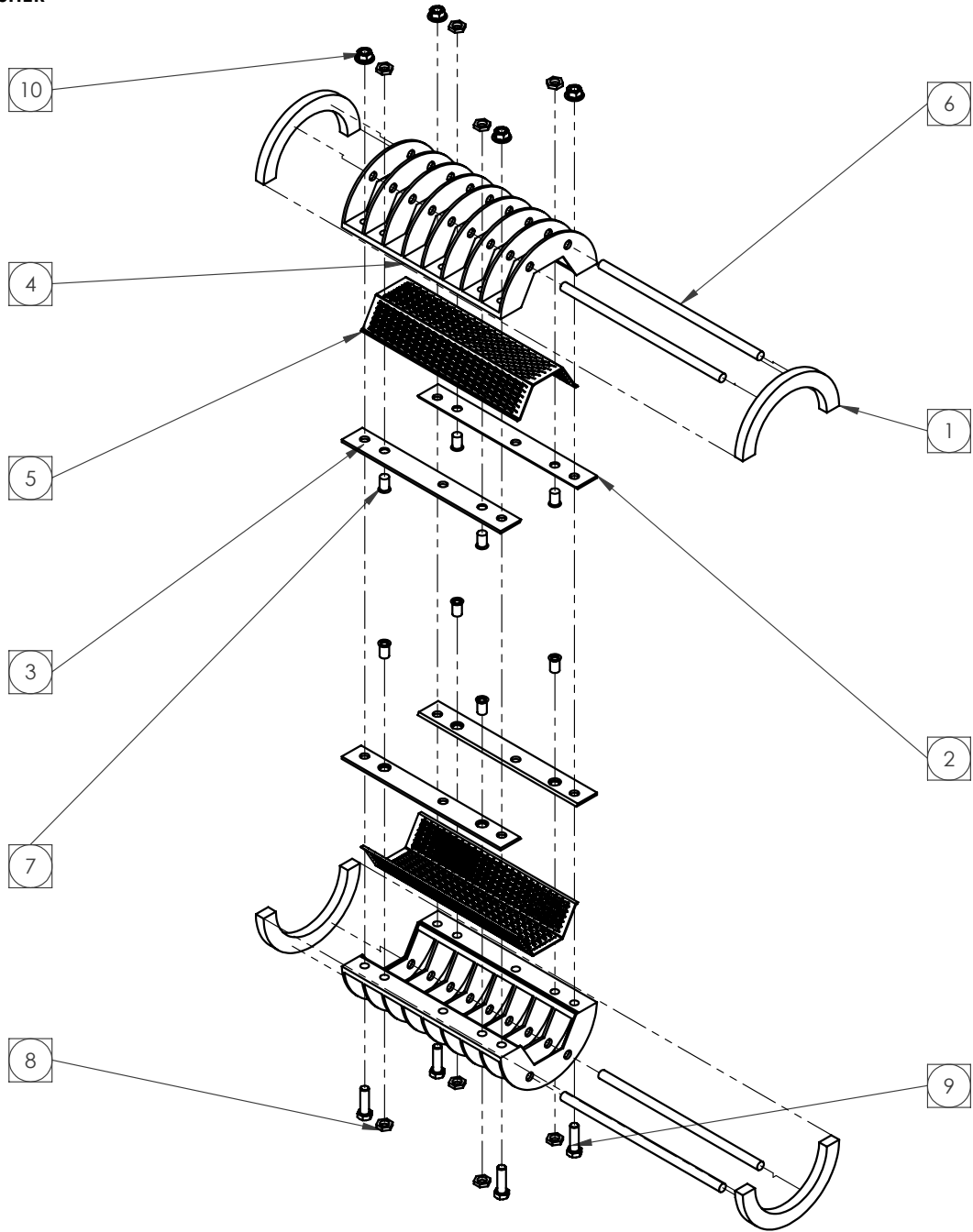

NOTE: DEBURR AND BREAK SHARP EDGES ALL BENDS MIN. RADIUS UNLESS SPECIFIED

UNLESS OTHERWISE SPECIFIED:
 STD. TOLERANCE
 DIMENSIONS ARE IN MILLIMETER
 MILLIMETER: ± 0.1
 ANGULAR: ± 0.5°
 * DOES NOT APPLY TO HOLE SIZE



BANGLADESH RICE RESEARCH INSTITUTE
 SFMRA PROJECT, FMPHT DIVISION

DO NOT SCALE DRAWING
 FINISH: NONE
 FIRST ISSUED: 02-AUG-2023

	NAME	SIGNATURE	DATE	TITLE: BRRI COMPACT RICE MILL (BRRI RM2023)
DRAWN	ENGR. SHAFIER JAHAN KHAN	S J K	03-DEC-2023	DRG. NAME: S-6.B_POLISHER SUB-ASSEMBLY (EXPLODED VIEW)
CHK'D	DR. MD. MOSHARRAF HOSSAIN	M M H	18-DEC-2023	
APPV'D	DR. AKM SAIFUL ISLAM	A S I	30-DEC-2023	
THIRD ANGLE PROJECTION:				DWG NO: RM2023_S-6.B-B
				MANUFACTURING METHOD: MACHINING, BENDING & WELDING
				WEIGHT: 14417.99 g
SCALE: 1:8		SHEET 17		REVISION: A

POLISHER BLOWER

ITEM NO.	Description	PartNo	Material	QTY.
1	POLISHER BLOWER CARRYING CASE	RM2023_S-6-C-141	Plain Carbon Steel	1
2	POLISHER BLOWER CASE PART	RM2023_S-6-C-140	ASTM A36 Steel	1
3	RUBBER SEAL OF POLISHER BLOWER	RM2023_S-6-C-139	Rubber	1
4	POLISHER BLOWER ADJUSTING PART	RM2023_S-6-C-142	ASTM A36 Steel	1
5	POLISHER BLOWER	RM2023_S-6-C-143	Cast Alloy Steel	1
6	M8 x .75mm x 20mm BOLT	N/A	STAINLESS STEEL	4
7	M8 x .75mm x 6mm NUT	N/A	STAINLESS STEEL	4

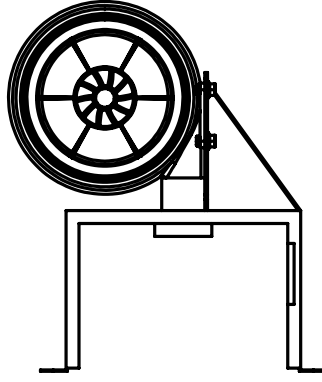
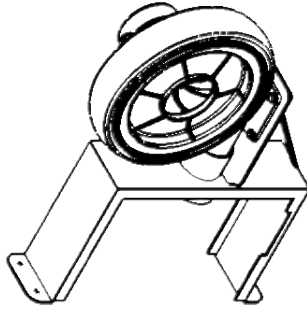

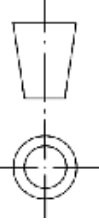
UNLESS OTHERWISE SPECIFIED: STD. TOLERANCE DIMENSIONS ARE IN MILLIMETER MILLIMETER: ±0.1, ANGULAR: ± 0.05° * DOES NOT APPLY TO HOLE SIZE				BANGLADESH RICE RESEARCH INSTITUTE SFMRA PROJECT, FMPT DIVISION		DO NOT SCALE DRAWING	
DETAILS		NAME	SIGNATURE	DATE	FINISH: NONE		
DRAWN		ENGR. SHAFER JAHAN KHAN	S J K	03-DEC-2023	FIRST ISSUED: 02-AUG-2023		
CHK'D		DR. MD. MOSHARRAF HOSSAIN	M M H	18-DEC-2023	TITLE: BRRI COMPACT RICE MILL (BRRI RM2023)		
APP'D		DR. AKM SAIFUL ISLAM	A S I	30-DEC-2023	DRG. NAME: S-6.C_ POLISHER BLOWER SUB-ASSEMBLY		
THIRD ANGLE PROJECTION:				DWG NO: RM2023_S-6-C-A			
NOTE: DEBURR AND BREAK SHARP EDGES ALL BENDS MIN. RADIUS UNLESS SPECIFIED		MANUFACTURING METHOD: MOLDING, MACHINING, BENDING & WELDING		WEIGHT: 10869.44 g			
		SCALE: 1:10		SHEET 18		REVISION: A	

POLISHER BLOWER

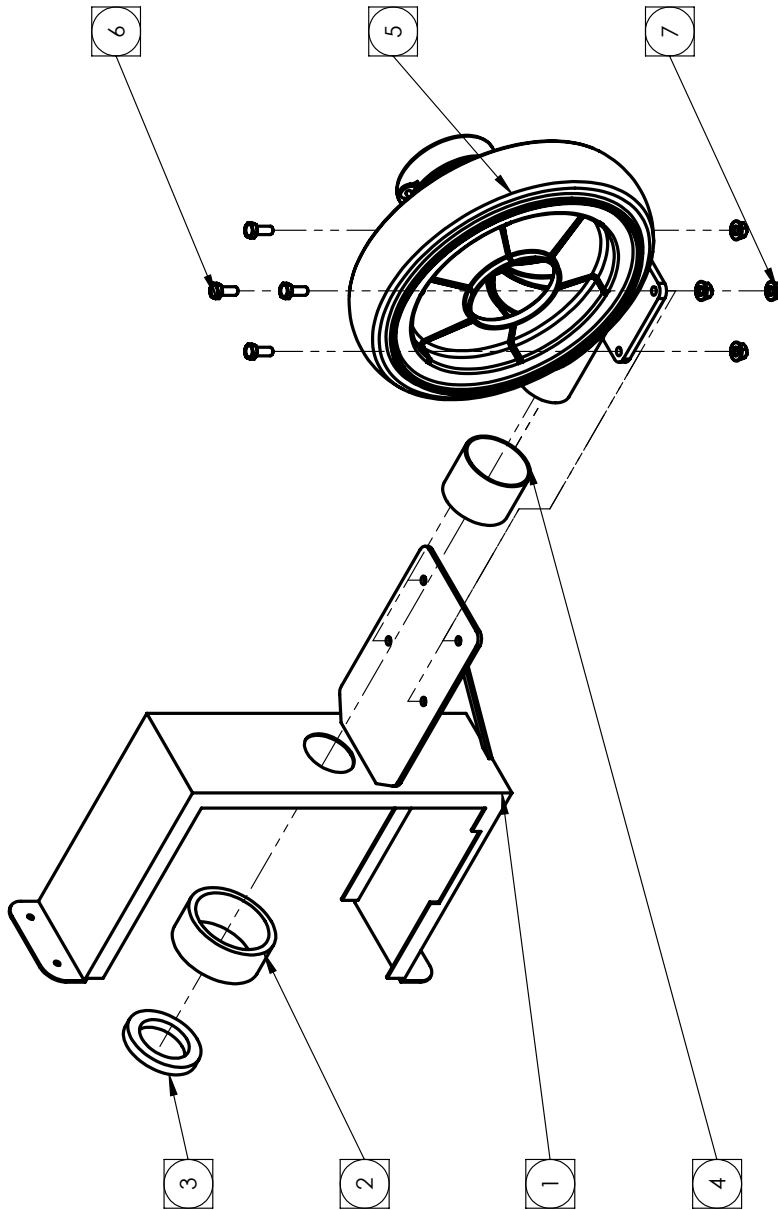

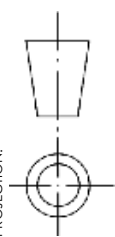
UNLESS OTHERWISE SPECIFIED: STD. TOLERANCE DIMENSIONS ARE IN MILLIMETER MILLIMETER: ±0.1, ANGULAR: ±0.05° * DOES NOT APPLY TO HOLE SIZE				BANGLADESH RICE RESEARCH INSTITUTE SFMRA PROJECT, FMPHT DIVISION		DO NOT SCALE DRAWING	
DETAILS		NAME	SIGNATURE	DATE	FINISH: NONE		
DRAWN		ENGR. SHAFER JAHAN RHAN	S J K	03-DEC-2023	FIRST ISSUED: 02-AUG-2023		
CHK'D	DR. MD. MOSHARRAF HOSSAIN	M M H		18-DEC-2023	TITLE: BRRI COMPACT RICE MILL (BRRI RM2023)		
APP'D	DR. AKM SAIBUL ISLAM	A S I		30-DEC-2023	DRG. NAME: S-6.C_POLISHER BLOWER SUB-ASSEMBLY (EXPLODED VIEW)		
THIRD ANGLE PROJECTION:							
NOTE: DEBURR AND BREAK SHARP EDGES ALL BENDS MIN. RADIUS UNLESS SPECIFIED				DWG NO: RM2023_S-6-C-B			
				MANUFACTURING METHOD: MOLDING, MACHINING, BENDING & WELDING			
				WEIGHT: 10861.94 g			
				SCALE: 1:6			
				SHEET 19		REVISION: A	

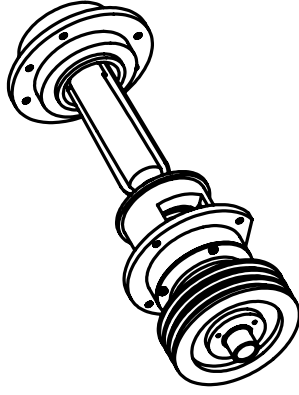

POLISHER MECHANISM

ITEM NO.	DESCRIPTION	PartNo	Material	QTY.
1	POLISHER SHAFT - NOZZLE SHAPED	RM2023_S-6.D-148	Plain Carbon Steel	1
2	POLISHER SHAFT -1- JAM NUT	RM2023_S-6.D-149	Plain Carbon Steel	1
3	POLISHER AIR CIRCULATING PART	RM2023_S-6.D-150	Plain Carbon Steel	1
4	POLISHER WORM GEAR	RM2023_S-6.D-151	ASTM A36 Steel	1
5	POLISHER SHAFT PART - 2	RM2023_S-6.D-152	Plain Carbon Steel	1
6	POLISHER BLOWER AIR INLET PART - FLANGE	RM2023_S-6.D-153	Plain Carbon Steel	1
7	POLISHER RICE DELIVERY - FLANGE - 1	RM2023_S-6.D-144	Plain Carbon Steel	1
8	POLISHER RICE DELIVERY - FLANGE - 2	RM2023_S-6.D-145	Plain Carbon Steel	1
9	POLISHER BLOWER AIR INLET PART	RM2023_S-6.D-154	Plain Carbon Steel	1
10	POLISHER SHAFT JAM NUT-1	RM2023_S-6.D-146	Plain Carbon Steel	1
11	NSK RADIAL BALL BEARING 6314	RM2023_S-6.D-156	Stainless Steel (ferritic)	1
12	POLISHER SHAFT JAM NUT-1	RM2023_S-6.D-155	Plain Carbon Steel	1
13	POLISHER V-PULLEY	RM2023_S-6.D-157	ASTM A36 Steel	1
14	POLISHER PULLEY JAM NUT	RM2023_S-6.D-158	ASTM A36 Steel	1
15	BOLT M8	N/A	SS	8
16	RADIAL BALL BEARING_68_SKF	RM2023_S-6.D-147	Stainless Steel (ferritic)	1

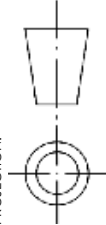
		BANGLADESH RICE RESEARCH INSTITUTE SFMRA PROJECT, FMPHT DIVISION		DO NOT SCALE DRAWING	
				FINISH: NONE FIRST ISSUED: 02-AUG-2023	
UNLESS OTHERWISE SPECIFIED: STD. TOLERANCE DIMENSIONS ARE IN MILLIMETER MILLIMETER: ±0.1, ANGULAR: ± 0.05° * DOES NOT APPLY TO HOLE SIZE		SIGNATURE S J K	DATE 03-DEC-2023	TITLE: BRRI COMPACT RICE MILL (BRRI RM2023) DRG. NAME: S-6.D_POLISHER MECHANISM SUB-ASSEMBLY DWG NO: RM2023_S-6.D-A	
DRAWN ENGR. SHAFER JAHAN KHAN	CHECKED DR. MD. MOSHARRAF HOSSAIN	APPROVED DR. AKM SAIFUL ISLAM	DATE 18-DEC-2023 30-DEC-2023		
THIRD ANGLE PROJECTION: 				SHEET 20	
				REVISION: A	

NOTE: DEBURR AND BREAK SHARP EDGES ALL BENDS MIN. RADIUS UNLESS SPECIFIED

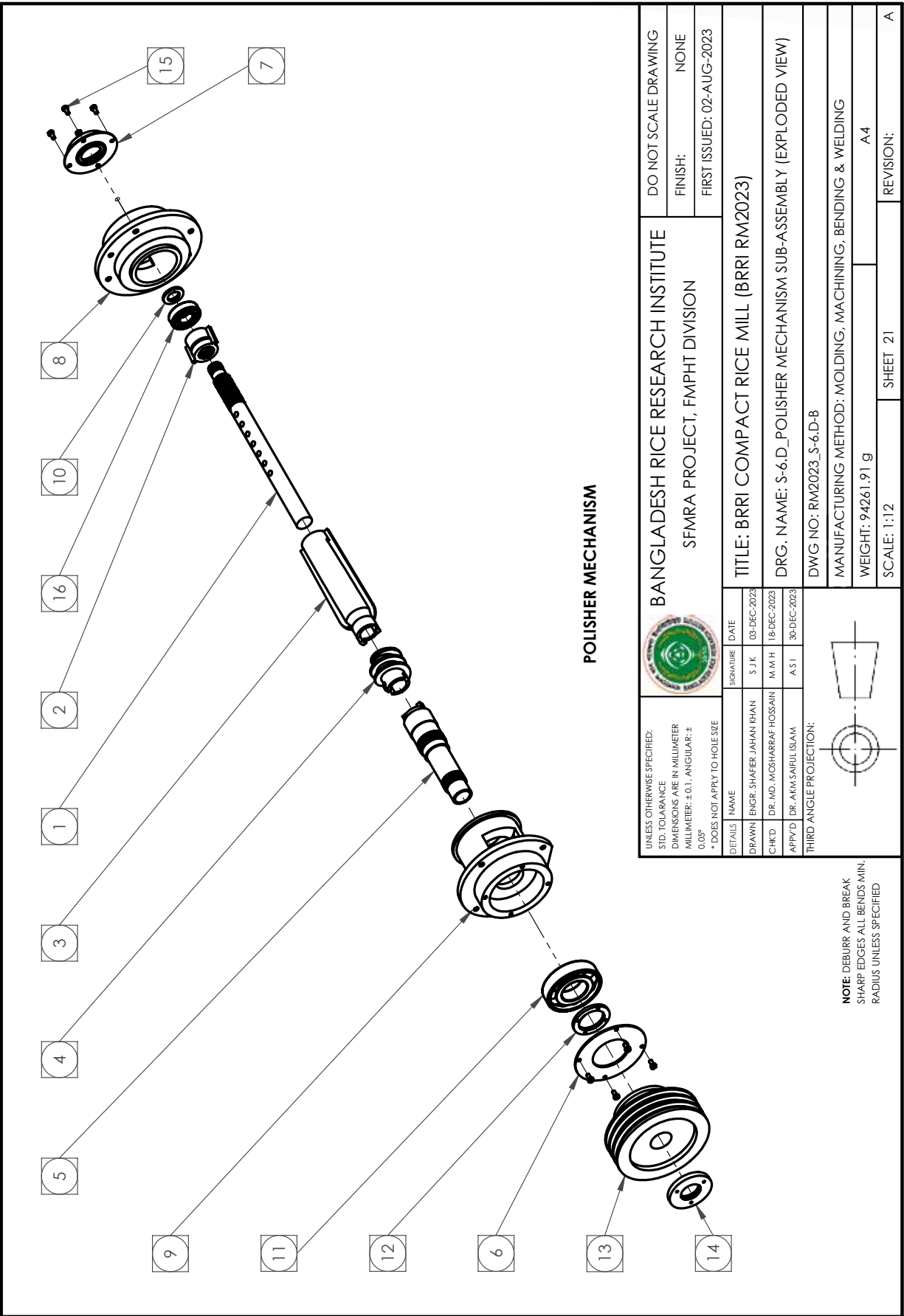

POLISHER MECHANISM

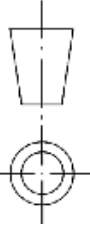
UNLESS OTHERWISE SPECIFIED: STD. TOLERANCE DIMENSIONS ARE IN MILLIMETER MILLIMETER: ±0.1, ANGULAR: ±0.05° * DOES NOT APPLY TO HOLE SIZE				DO NOT SCALE DRAWING	
BANGLADESH RICE RESEARCH INSTITUTE SFMRA PROJECT, FMPHT DIVISION		TITLE: BRRI COMPACT RICE MILL (BRRI RM2023)		FINISH: NONE	
DETAILS		NAME	SIGNATURE	DATE	FIRST ISSUED: 02-AUG-2023
CHK'D	DR. MD. MOSHARRAF HOSSAIN	ENGR. SHAFER JAHAN KHAN	S. J.K	03-DEC-2023	
APP'VD	DR. AKM SAIBUL ISLAM		M. M.H	18-DEC-2023	
THIRD ANGLE PROJECTION:				DRG. NAME: S-6.D_POLISHER MECHANISM SUB-ASSEMBLY (EXPLODED VIEW)	
				DWG NO: RM2023_S-6.D-B	
				MANUFACTURING METHOD: MOLDING, MACHINING, BENDING & WELDING	
				WEIGHT: 94261.91 g	
				SCALE: 1:12	
				SHEET 21	
				REVISION: A	

NOTE: DEBURR AND BREAK SHARP EDGES ALL BENDS MIN. RADIUS UNLESS SPECIFIED

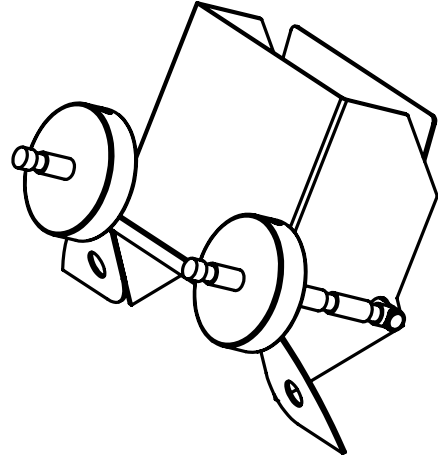

ITEM NO.	DESCRIPTION	PartNo	Material	QTY.
1	RICE DELIVERY BODY PART-2	RM2023_S-6-E-161	Plain Carbon Steel	1
2	RICE DELIVERY PART-CONTROL GATE PART-1	RM2023_S-6-E-159	Plain Carbon Steel	1
3	RICE DELIVERY PART-CONTROL GATE PART-2	RM2023_S-6-E-159	Plain Carbon Steel	2
4	RICE DELIVERY PART-CONTROL GATE PART-3	RM2023_S-6-E-159	Plain Carbon Steel	1
5	RICE DELIVERY BODY PART-1	RM2023_S-6-E-160	Plain Carbon Steel	1
6	RICE DELIVERY PART-WEIGHT	RM2023_S-6-E-162	Plain Carbon Steel	2
7	RICE DELIVERY PART-WEIGHT BALL	RM2023_S-6-E-163	Plain Carbon Steel	2
8	RICE DELIVERY PART - SPRING - CONTROLLER	RM2023_S-6-E-164	Plain Carbon Steel	2

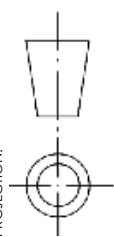
		BANGLADESH RICE RESEARCH INSTITUTE SFMRA PROJECT, FMPHT DIVISION		DO NOT SCALE DRAWING
				FINISH: NONE
				FIRST ISSUED: 02-AUG-2023
UNLESS OTHERWISE SPECIFIED: STD. TOLERANCE DIMENSIONS ARE IN MILLIMETER MILLIMETER: ±0.1, ANGULAR: ± 0.05° * DOES NOT APPLY TO HOLE SIZE		SIGNATURE S J K	DATE 03-DEC-2023	TITLE: BRRI COMPACT RICE MILL (BRRI RM2023)
DRAWN ENGR. SHAFER JAHAN KHAN	M M H	18-DEC-2023	DRG. NAME: S-6.E_RICE DELIVERY SECTION SUB-ASSEMBLY	
CHKD DR. MD. MOSHARRAF HOSSAIN	A S I	30-DEC-2023	DWG NO: RM2023_S-6-E-A	
APPVD DR. AKM SAIBUL ISLAM	THIRD ANGLE PROJECTION: 		MANUFACTURING METHOD: MOLDING, MACHINING, BENDING & WELDING	
NOTE: DEBURR AND BREAK SHARP EDGES ALL BENDS MIN. RADIUS UNLESS SPECIFIED			WEIGHT: 1720.75 g SCALE: 1:3	REVISION: A
			SHEET 22	

RICE DELIVERY SECTION

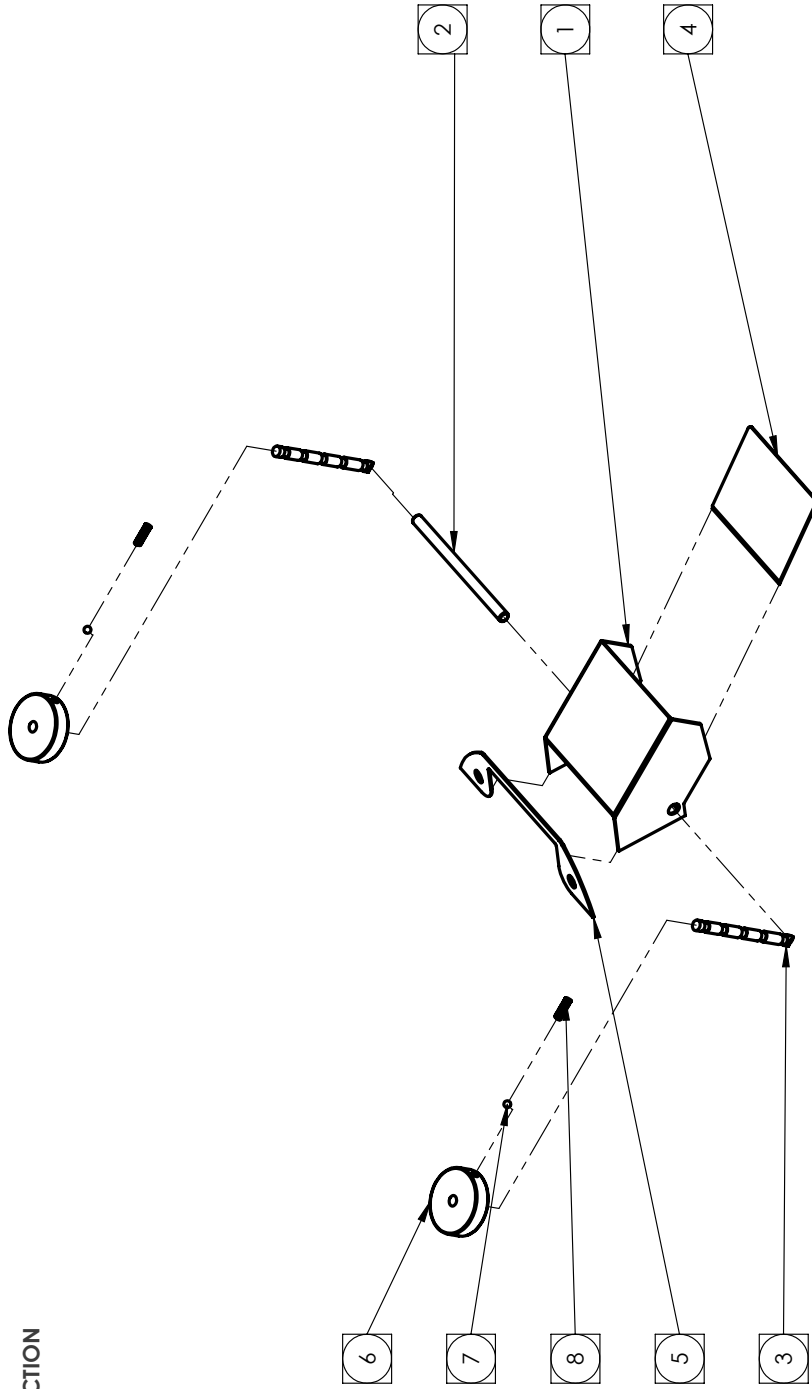

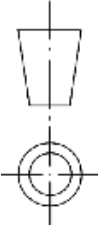
UNLESS OTHERWISE SPECIFIED: STD. TOLERANCE DIMENSIONS ARE IN MILLIMETER MILLIMETER: ±0.1, ANGULAR: ± 0.05° * DOES NOT APPLY TO HOLE SIZE				BANGLADESH RICE RESEARCH INSTITUTE SFMRA PROJECT, FMPHT DIVISION		DO NOT SCALE DRAWING FINISH: NONE FIRST ISSUED: 02-AUG-2023	
DETAILS	NAME	SIGNATURE	DATE	TITLE: BRRI COMPACT RICE MILL (BRRI RM2023)			
DRAWN	ENGR. SHAFER JAHAN KHAN	S. J.K	03-DEC-2023	DRG. NAME: S-6.E_RICE DELIVERY SECTION SUB-ASSEMBLY (EXPLODED VIEW)			
CHK'D	DR. MD. MOSHARRAF HOSSAIN	M. M.H	18-DEC-2023	DWG NO: RM2023_S-6.E-B			
APP'D	DR. AKM SAIBUL ISLAM	A.S.I	30-DEC-2023	MANUFACTURING METHOD: MOLDING, MACHINING, BENDING & WELDING			
THIRD ANGLE PROJECTION:							
NOTE: DEBURR AND BREAK SHARP EDGES ALL BENDS MIN. RADIUS UNLESS SPECIFIED				SCALE: 1:6		REVISION: A	
				WEIGHT: 1720.75 g		SHEET 23	

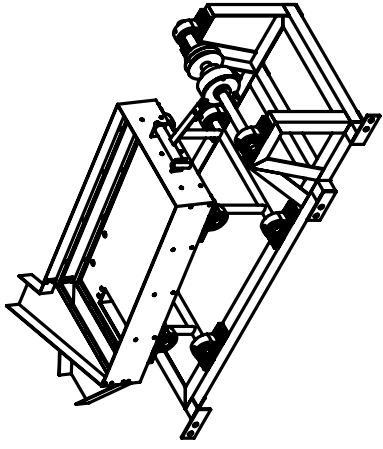

SIZE GRADER

ITEM NO.	Description	PartNo	Material	QTY.
1	GRADER FRAME	RM2023_36.F-165	Plain Carbon Steel	1
2	UCP 204	RM2023_36.F-175	ASTM A36 Steel	10
3	GRADER MAIN SHAFT PART - 2	RM2023_36.F-174	Plain Carbon Steel	1
4	GRADER SHAFT	RM2023_36.F-166	Plain Carbon Steel	1
5	CAM FLANGE	RM2023_36.F-169	Plain Carbon Steel	1
6	FND 6208 BEARING	RM2023_36.F-170	Stainless Steel (ferritic)	1
7	CAM	RM2023_36.F-171	Plain Carbon Steel	1
8	CAM BEARING HOLDER	RM2023_36.F-172	Plain Carbon Steel	1
9	GRADER CASING	RM2023_36.F-176	Plain Carbon Steel	1
10	ANGLE BAR FRAME - 1	RM2023_36.F-177	Plain Carbon Steel	1
11	GRADER OUTPUT CASING - 1	RM2023_36.F-178	Plain Carbon Steel	1
12	GRADER BOTTOM CASING NET - 1 (SIZE - 16)	RM2023_36.F-179	Plain Carbon Steel	1
13	FLAT BAR FRAME - 1	RM2023_36.F-180	Plain Carbon Steel	1
14	ANGLE BAR FRAME - 2	RM2023_36.F-181	Plain Carbon Steel	1
15	GRADER OUTPUT CASING - 2	RM2023_36.F-182	Plain Carbon Steel	1
16	FLAT BAR FRAME - 2	RM2023_36.F-184	Plain Carbon Steel	1
17	GRADER CAM FOLLOWER PART	RM2023_36.F-185	Plain Carbon Steel	1
18	GRADER CAM FOLLOWER BOLT	RM2023_36.F-186	Plain Carbon Steel	1
19	GRADER CAM FOLLOWER NUT	RM2023_36.F-172	Plain Carbon Steel	1
20	GRADER MAIN SHAFT PART - 1	RM2023_36.F-173	Plain Carbon Steel	1
21	WELDMENTS FRAME-BASE	RM2023_36.F-187	Plain Carbon Steel	1
22	GRADER PULLEY	RM2023_36.F-167	Gray Cast Iron	1
23	GRADER BOTTOM CASING NET - 2 (SIZE - 14)	RM2023_36.F-183	Plain Carbon Steel	1

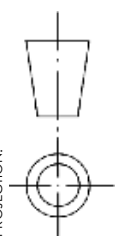
		BANGLADESH RICE RESEARCH INSTITUTE SFMRA PROJECT, FMPHT DIVISION		DO NOT SCALE DRAWING	
		TITLE: BRRI COMPACT RICE MILL (BRRI RM2023) DRG. NAME: 6.G_SIZE GRADER SUB-ASSEMBLY DWG NO: RM2023_36.F-A		FINISH: NONE FIRST ISSUED: 02-AUG-2023	
UNLESS OTHERWISE SPECIFIED: STD. TOLERANCE DIMENSIONS ARE IN MILLIMETER MILLIMETER: ±0.1, ANGULAR: ± 0.05° * DOES NOT APPLY TO HOLE SIZE		SIGNATURE S J K M M H A S I	DATE 03-DEC-2023 18-DEC-2023 30-DEC-2023	MANUFACTURING METHOD: MOLDING, MACHINING, BENDING & WELDING WEIGHT: 38252.25 g SCALE: 1:20	
THIRD ANGLE PROJECTION: 		DR. MD. MOSHARRAF HOSSAIN DR. AKM SAIBUL ISLAM		SHEET 24 REVISION: A	

NOTE: DEBURR AND BREAK SHARP EDGES ALL BENDS MIN. RADIUS UNLESS SPECIFIED

SIZE GRADER

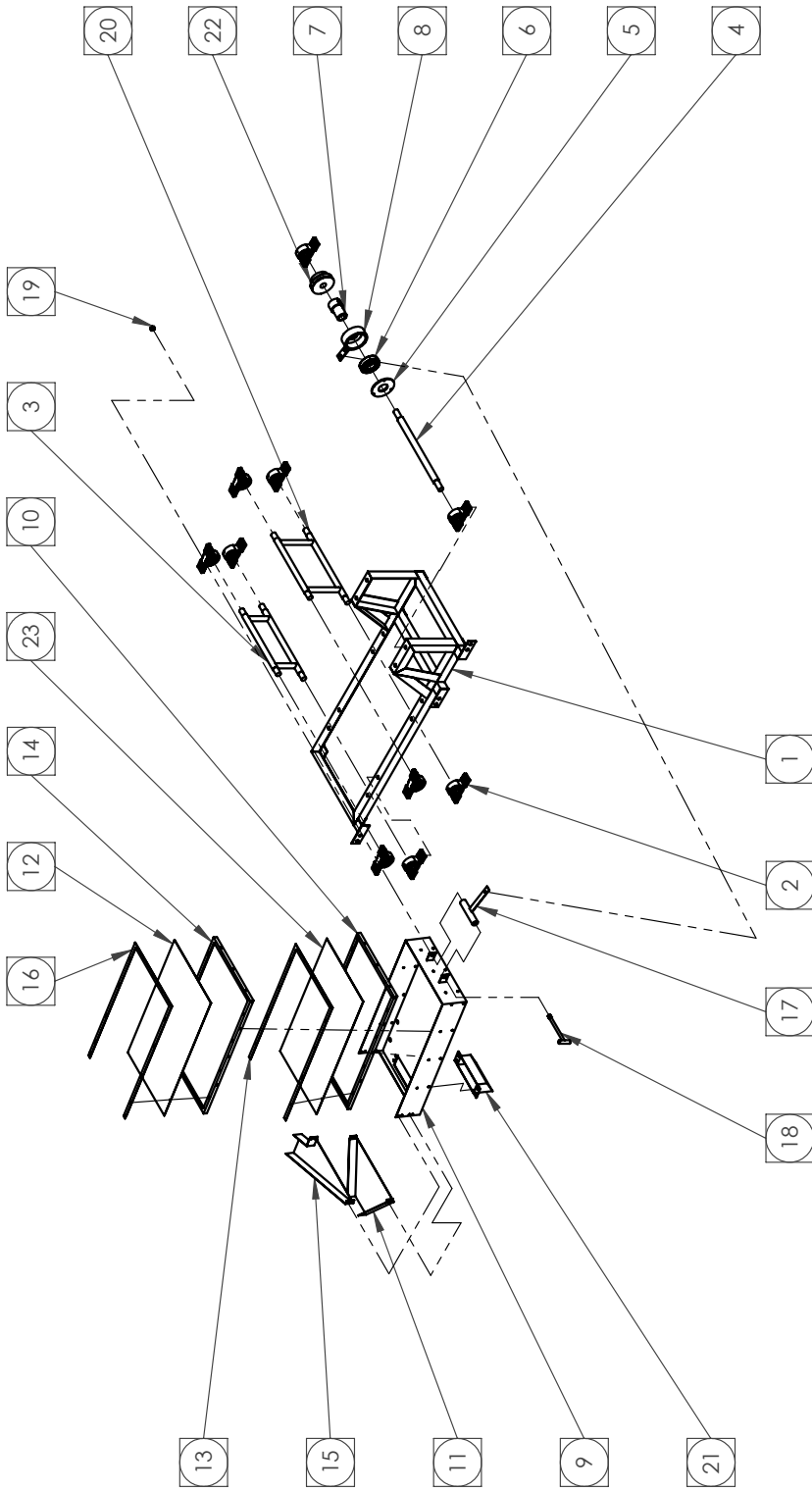

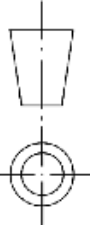
		BANGLADESH RICE RESEARCH INSTITUTE SFMRA PROJECT, FMPHT DIVISION		DO NOT SCALE DRAWING FINISH: NONE FIRST ISSUED: 02-AUG-2023	
UNLESS OTHERWISE SPECIFIED: STD. TOLERANCE DIMENSIONS ARE IN MILLIMETER MILLIMETER: ±0.1, ANGULAR: ± 0.05° * DOES NOT APPLY TO HOLE SIZE		SIGNATURE S. J.K	DATE 03-DEC-2023	TITLE: BRRI COMPACT RICE MILL (BRRI RM2023)	
DRAWN ENGR. SHAFER JAHAN KHAN	M. M.H	18-DEC-2023	DRG. NAME: 6_G_SIZE GRADER SUB-ASSEMBLY (EXPLODED VIEW)		
CHK'D DR. MD. MOSHARRAF HOSSAIN	A.S.I	30-DEC-2023	DWG NO: RM2023_S6.F-B		
THIRD ANGLE PROJECTION: 			MANUFACTURING METHOD: MOLDING, MACHINING, BENDING & WELDING		
NOTE: DEBURR AND BREAK SHARP EDGES ALL BENDS MIN. RADIUS UNLESS SPECIFIED			WEIGHT: 38252.25 g SCALE: 1:25	SHEET 25	REVISION: A

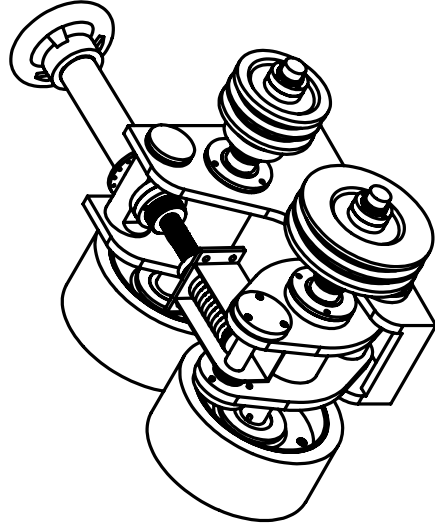

RUBBER ROLLER SETTING BODY

ITEM NO.	Description	PartNo	Material	Qty.
1	RRSB - ADJUSTING CLAMP_PART1	RM2023_S-7-188	Plain Carbon Steel	1
2	RRSB-THREAD SHAFT ADJUSTER	RM2023_S-7-200	ASTM A36 Steel	1
3	RRSB-SHAFT 1	RM2023_S-7-195	Plain Carbon Steel	1
4	JAM NUT-SHAFT DIA. 45mm THREAD	RM2023_S-7-205	ASTM A36 Steel	1
5	JAM NUT-SHAFT DIA. 45mm	RM2023_S-7-206	ASTM A36 Steel	1
6	RRSB - GAP CONTROLLER THREAD SHAFT	RM2023_S-7-202	ASTM A36 Steel	1
7	RRSB-SPRING SETUP BOX	RM2023_S-7-201	ASTM A36 Steel	1
8	JAM NUT-SHAFT DIA. 23mm	RM2023_S-7-204	ASTM A36 Steel	2
9	RRSB-THREAD SHAFT SPRING	RM2023_S-7-185	ASTM A36 Steel	1
10	RRSB - ADJUSTING CLAMP_PART2	RM2023_S-7-189	Plain Carbon Steel	1
11	RRSB CLAMP-PIN LOCK_PART1	RM2023_S-7-190	ASTM A36 Steel	1
12	RRSB CLAMP-PIN LOCK_PART2	RM2023_S-7-191	ASTM A36 Steel	1
13	RRSB ADJUSTING CLAMP-PIN LOCK_PART3	RM2023_S-7-193	ASTM A36 Steel	2
14	RRSB-1-FLANGE	RM2023_S-7-176	ASTM A36 Steel	4
15	SHAFT JAM NUT	RM2023_S-7-198	ASTM A36 Steel	10
16	HTFJ33-1(G5C3)NSK) - BEARING	RM2023_S-7-194	Stainless Steel (ferritic)	4
17	RRSB SHAFT LOCK PART	RM2023_S-7-196	ASTM A36 Steel	2
18	RRSB SHAFT-2	RM2023_S-7-174	Plain Carbon Steel	1
19	RRSB CLAMP-PIN LOCK_SCREW	RM2023_S-7-192	Stainless Steel (ferritic)	12
20	RRSB-PULLEY-SHAFT-1	RM2023_S-7-210	Gray Cast Iron	1
21	RRSB-ADJUSTING SHAFT-2	RM2023_S-7-203	ASTM A36 Steel	1
22	RRSB-PULLEY-SHAFT 2	RM2023_S-7-211	Gray Cast Iron	1
23	RRSB-ADJUSTING LOCK-SHAFT-1	RM2023_S-7-212	ASTM A36 Steel	1
24	RRSB-SETTING FLANGE-SHAFT-1	RM2023_S-7-213	ASTM A36 Steel	1
25	RRSB-RUBBER ROLLER 6in	RM2023_S-7-209	Plain Carbon Steel	2
26	RRSB - SHAFT- 2 - ADJUSTING LOCK	RM2023_S-7-214	ASTM A36 Steel	1
27	RRSB-SETTING FLANGE-SHAFT-2	RM2023_S-7-215	ASTM A36 Steel	1
28	RRSB-GAP CONTROLLER DEVICE (MANUAL)	RM2023_S-7-207	ASTM A36 Steel	1



BANGLADESH RICE RESEARCH INSTITUTE
 SFMRA PROJECT, FMPHT DIVISION

TITLE: BRRI COMPACT RICE MILL (BRRI RM2023)

DRG. NAME: S-7_RUBBER ROLLER SETTING BODY SUB-ASSEMBLY

DWG NO: RM2023_S-7-A

MANUFACTURING METHOD: MOLDING, MACHINING, BENDING & WELDING

WEIGHT: 78512.14 g

A4

SCALE: 1:8

SHEET 26

REVISION:

A

UNLESS OTHERWISE SPECIFIED:
 STD. TOLERANCE
 DIMENSIONS ARE IN MILLIMETER
 MILLIMETER: ±0.1, ANGULAR: ±
 0.05°
 * DOES NOT APPLY TO HOLE SIZE

DETAILS	NAME	SIGNATURE	DATE
DRAWN	ENGR. SHAFER JAHAN RHAN	S J K	03-DEC-2023
CHK'D	DR. MD. MOSHARRAF HOSSAIN	M M H	18-DEC-2023
APP'VD	DR. AKM SAIBUL ISLAM	A S I	30-DEC-2023

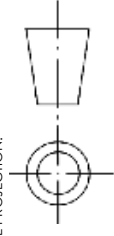

THIRD ANGLE PROJECTION:

NOTE: DEBURR AND BREAK SHARP EDGES ALL BENDS MIN. RADIUS UNLESS SPECIFIED

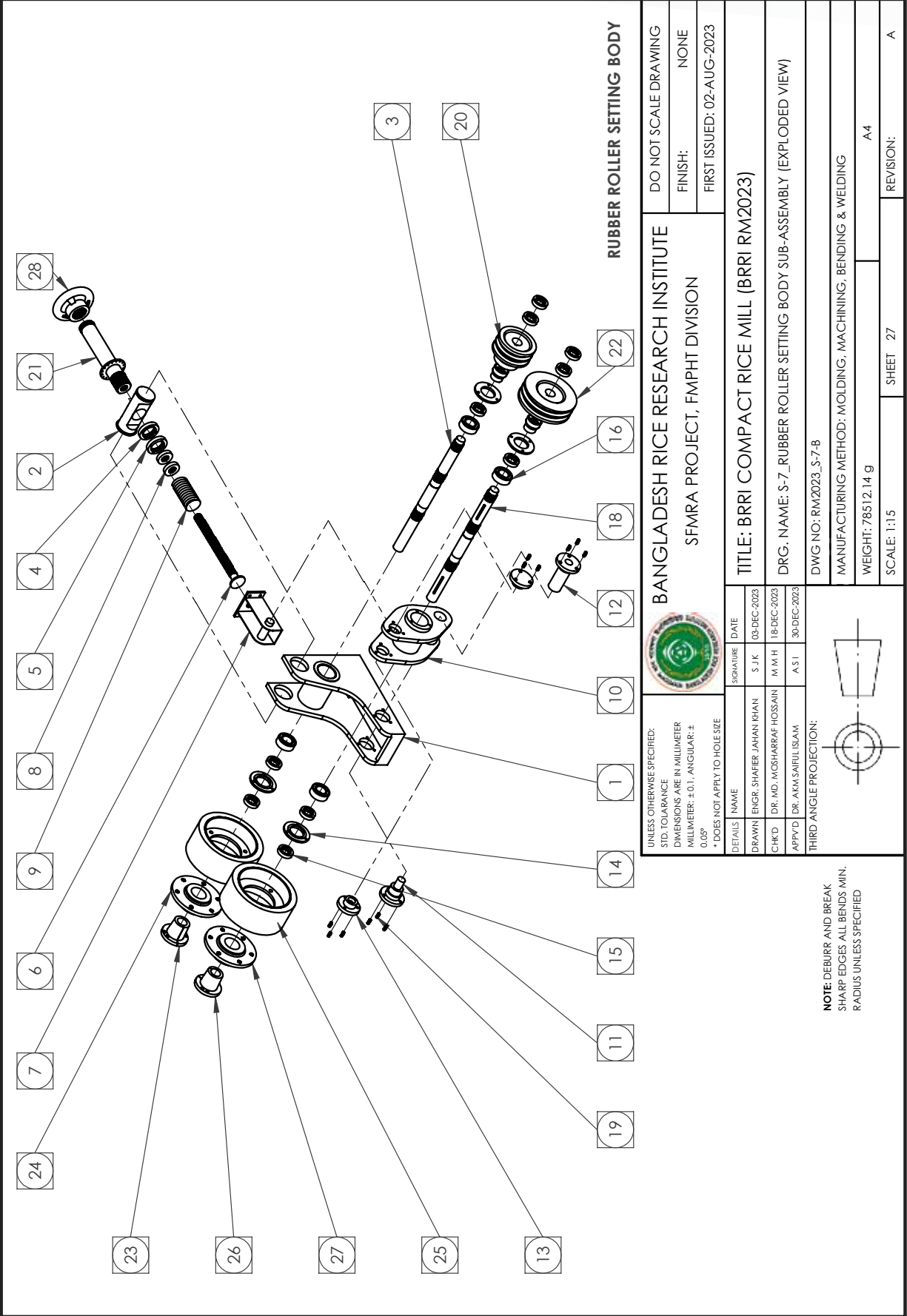

RUBBER ROLLER SETTING BODY

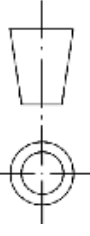
		BANGLADESH RICE RESEARCH INSTITUTE SFMRA PROJECT, FMPHT DIVISION		DO NOT SCALE DRAWING
		TITLE: BRRI COMPACT RICE MILL (BRRI RM2023)		FINISH: NONE
UNLESS OTHERWISE SPECIFIED: STD. TOLERANCE DIMENSIONS ARE IN MILLIMETER MILLIMETER: ±0.1, ANGULAR: ± 0.05° * DOES NOT APPLY TO HOLE SIZE		DETAILS NAME SIGNATURE DATE DRAWN ENGR. SHAFER JAHAN KHAN S.J.K 03-DEC-2023 CHK'D DR. MD. MOSHARRAF HOSSAIN M.M.H 18-DEC-2023 APP'D DR. AKM SAIBUL ISLAM A.S.I 30-DEC-2023	FIRST ISSUED: 02-AUG-2023	
DRG. NAME: S-7_RUBBER ROLLER SETTING BODY SUB-ASSEMBLY (EXPLODED VIEW)		DWG NO: RM2023_S-7-B		
THIRD ANGLE PROJECTION: 		MANUFACTURING METHOD: MOLDING, MACHINING, BENDING & WELDING		
NOTE: DEBURR AND BREAK SHARP EDGES ALL BENDS MIN. RADIUS UNLESS SPECIFIED		WEIGHT: 78512.14 g SCALE: 1:15		REVISION: A
		SHEET: 27		A4

TENSION PULLEY

ITEM NO.	Description	PartNo	Material	QTY.
1	TENSION PULLEY NUT_M33-3.50 x 18	N/A (IMPORTED)	Stainless Steel (ferritic)	2
2	TENSION SHAFT	RM2023_S-8-216	ASTM A36 Steel	1
3	TENSION PULLEY	RM2023_S-8-217	Gray Cast Iron	1
4	LOCK BOLT_M10-1.5 x 40	RM2023_S-8-219	Stainless Steel (ferritic)	1
5	TENSION PULLEY-ANGLE BAR PART	RM2023_S-8-218	Plain Carbon Steel	1

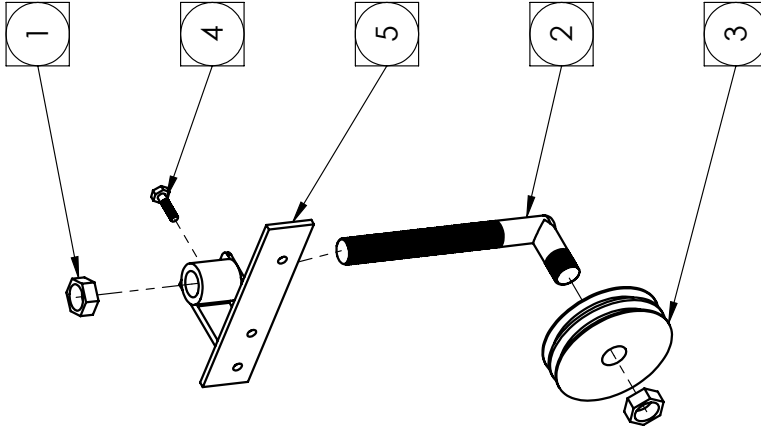
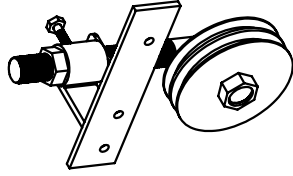

ISOMETRIC

ISOMETRIC EXPLODED

		DO NOT SCALE DRAWING FINISH: NONE FIRST ISSUED: 02-AUG-2023	
BANGLADESH RICE RESEARCH INSTITUTE SFMRA PROJECT, FMPHT DIVISION			
TITLE: BRRI COMPACT RICE MILL (BRRI RM2023)		DRG. NAME: S-8_TENSION PULLEY SUB-ASSEMBLY	
DWG NO: RM2023_S8-A		MANUFACTURING METHOD: MOLDING, MACHINING, BENDING & WELDING	
WEIGHT: 9814.00 g		SCALE: 1:4	
SHEET 28		REVISION: A	

UNLESS OTHERWISE SPECIFIED: STD. TOLERANCE DIMENSIONS ARE IN MILLIMETER MILLIMETER: ±0.1, ANGULAR: ± 0.05° * DOES NOT APPLY TO HOLE SIZE			
DETAILS	NAME	SIGNATURE	DATE
DRAWN	ENGR. SHAFER JAHAN KHAN	S J K	03-DEC-2023
CHK'D	DR. MD. MOSHARRAF HOSSAIN	M M H	18-DEC-2023
APP'VD	DR. AKM SAIBUL ISLAM	A S I	30-DEC-2023

THIRD ANGLE PROJECTION:

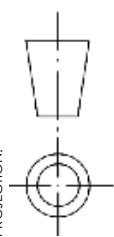

NOTE: DEBURR AND BREAK SHARP EDGES ALL BENDS MIN. RADIUS UNLESS SPECIFIED

HUSK CONVEYER

ITEM NO.	Description	PartNo	Material	QTY.
1	HUSK CONVEYER	RM2023_S-9-222	Plain Carbon Steel	1
2	HUSK CONVEYER PULLEY	RM2023_S-9-224	Gray Cast Iron	1
3	HUSK CONVEYER JAM NUT	RM2023_S-9-223	ASTM A36 Steel	1
4	HUSK CONVEYER ADJUSTING PLATE	RM2023_S-9-221	Plain Carbon Steel	1
5	SQUARE BRACKET BEARING 35MM UCF207	RM2023_S-9-124	ASTM A36 Steel	2
6	GRADER PULLEY	RM2023_S-9-225	Gray Cast Iron	1

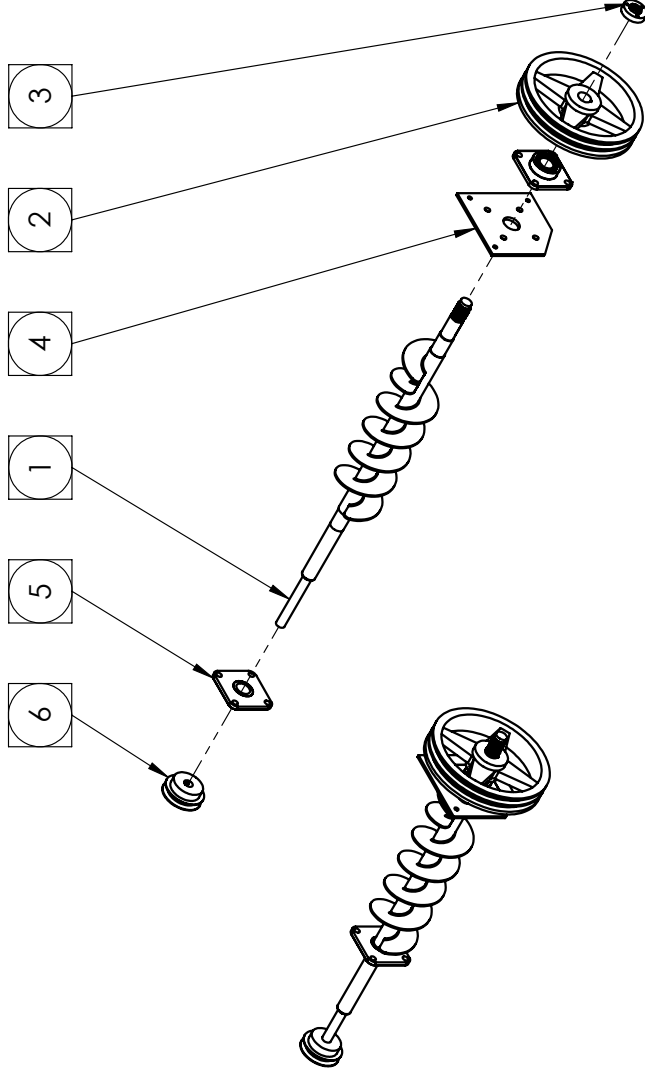

ISOMETRIC

ISOMETRIC EXPLODED

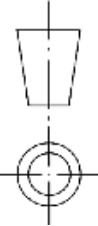
 UNLESS OTHERWISE SPECIFIED: STD. TOLERANCE DIMENSIONS ARE IN MILLIMETER MILLIMETER: ±0.1, ANGULAR: ± 0.05° * DOES NOT APPLY TO HOLE SIZE	BANGLADESH RICE RESEARCH INSTITUTE SFMRA PROJECT, FMPHT DIVISION		DO NOT SCALE DRAWING
	TITLE: BRRI COMPACT RICE MILL (BRRI RM2023) DRG. NAME: S-9_HUSK CONVEYER SUB-ASSEMBLY DWG NO: RM2023_S-9-A		FINISH: NONE FIRST ISSUED: 02-AUG-2023
DETAILS NAME DATE DRAWN ENGR. SHAFER JAHAN KHAN S J K 03-DEC-2023 CHK'D DR. MD. MOSHARRAF HOSSAIN M M H 18-DEC-2023 APP'VD DR. AKM SAIFUL ISLAM A S I 30-DEC-2023	THIRD ANGLE PROJECTION: 		
MANUFACTURING METHOD: MOLDING, MACHINING, BENDING & WELDING WEIGHT: 25766.70 g SCALE: 1:10		SHEET 29 REVISION: A	

NOTE: DEBURR AND BREAK SHARP EDGES ALL BENDS MIN. RADIUS UNLESS SPECIFIED

- N.B: C-CHANNEL SIZE (75x40x5)mm
- N.B: FLAT BAR SIZE (38x3)mm
- N.B: ANGLE BAR SIZE (38x38x3)mm
- N.B: ANGLE BAR SIZE (50x50x3)mm
- N.B: ANGLE BAR SIZE (25x25x2)mm

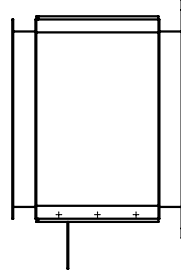
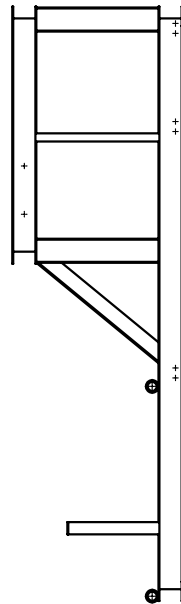
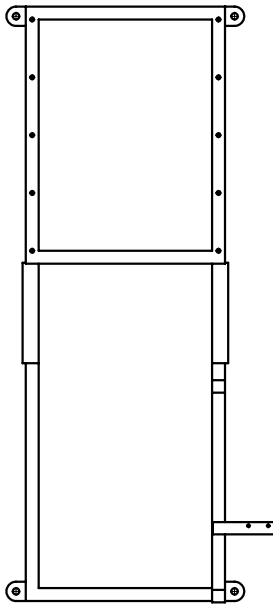
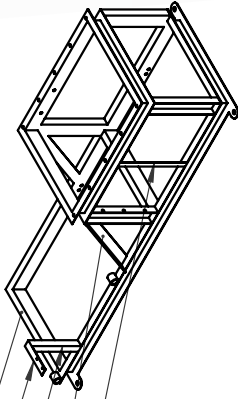

N.B: NOT A COMPLETE DRAWING. CHECK SHEETS 30-33 FOR COMPLETE DRAWINGS.

UNLESS OTHERWISE SPECIFIED:
 STD. TOLERANCE DIMENSIONS ARE IN MILLIMETER
 MILLIMETER: ±0.1, ANGULAR: ±0.05°
 * DOES NOT APPLY TO HOLE SIZE



BANGLADESH RICE RESEARCH INSTITUTE
 SFMRA PROJECT, FMPHT DIVISION

DO NOT SCALE DRAWING
 FINISH: NONE
 FIRST ISSUED: 02-AUG-2023

DETAILS	NAME	SIGNATURE	DATE
DRAWN	ENGR. SHAFER JAHAN KHAN	S J K	01-AUG-2023
CHK'D	DR. MD. MOSHARRAF HOSSAIN	M M H	18-DEC-2023
APP'VD	DR. AKM SAIBUL ISLAM	A S I	30-DEC-2023

TITLE: BRRI COMPACT RICE MILL (BRRI RM2023)
DRG. NAME: WELDMENTS FRAME BASE
 DWG NO: RM2023_s1-001

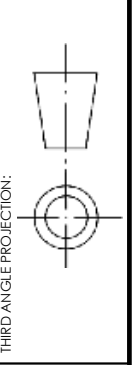

MANUFACTURING METHOD: MACHINING, BENDING & WELDING
 MATERIAL: Plain Carbon Steel
 WEIGHT: 36996.32 g
 SCALE: 1:1
 SHEET: 30
 REVISION: A

NOTE: DEBURR AND BREAK SHARP EDGES ALL BENDS MIN. RADIUS UNLESS SPECIFIED

N.B: *ONLY FRONT VIEW DIMENSIONS HAS SHOWN HERE.
 *CHECK NEXT PAGES FOR OTHER VIEWS AND SIZES.
 *NOT A COMPLETE DRAWING. CHECK SHEETS 30-33 FOR COMPLETE DRAWINGS.

- N.B: C-CHANNEL SIZE (75x40x5)mm
- N.B: FLAT BAR SIZE (38x3)mm
- N.B: ANGLE BAR SIZE (38x38x3)mm
- N.B: ANGLE BAR SIZE (50x50x3)mm
- N.B: ANGLE BAR SIZE (25x25x2)mm

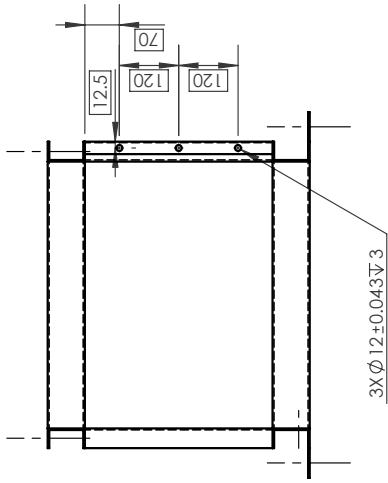
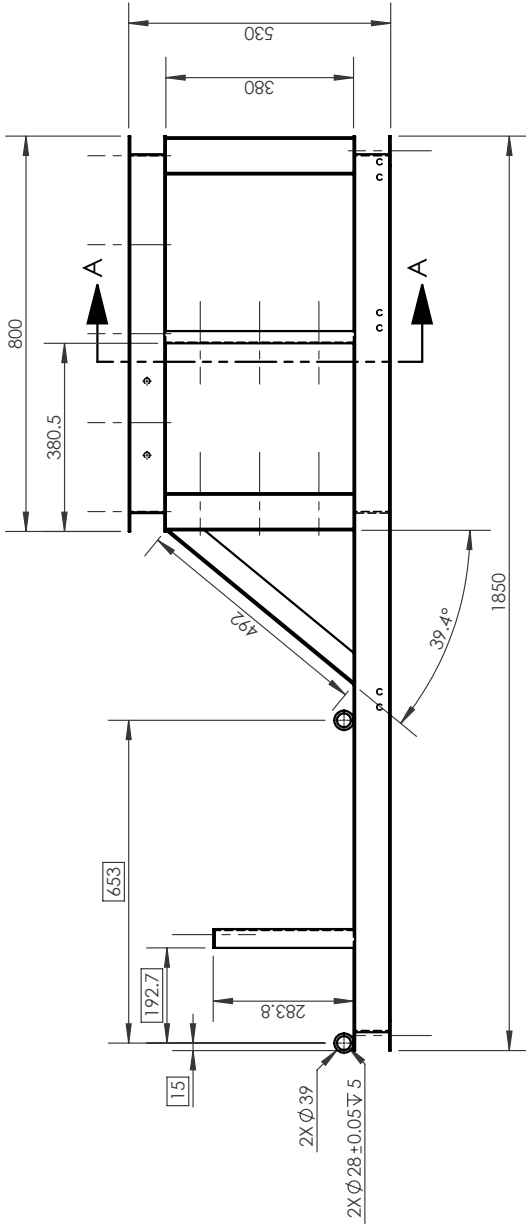
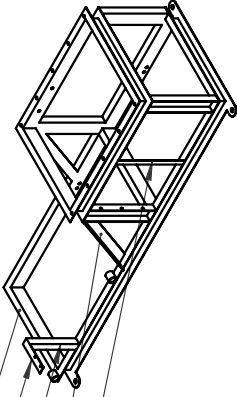

SECTION A-A
 SCALE 1 : 13

DWG NO: RM2023_S1-001
 SHEET NO: 31

N.B: *ONLY RIGHT VIEW HAS SHOWN HERE.
 *SECTION A-A IS SHOWING HOLE DIMENSIONS WHICH IS AVAILABLE IN ONLY ONE SIDE IN THE WELDMENTS FRAME.
 *NOT A COMPLETE DRAWING. CHECK SHEETS 30-33 FOR COMPLETE DRAWINGS.

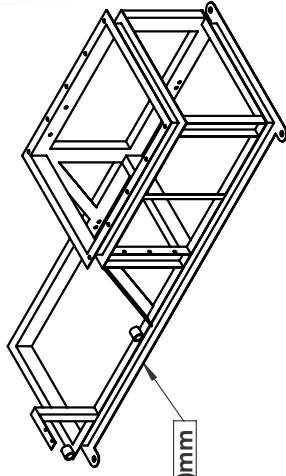

N.B: C-CHANNEL SIZE (75x40x5)mm

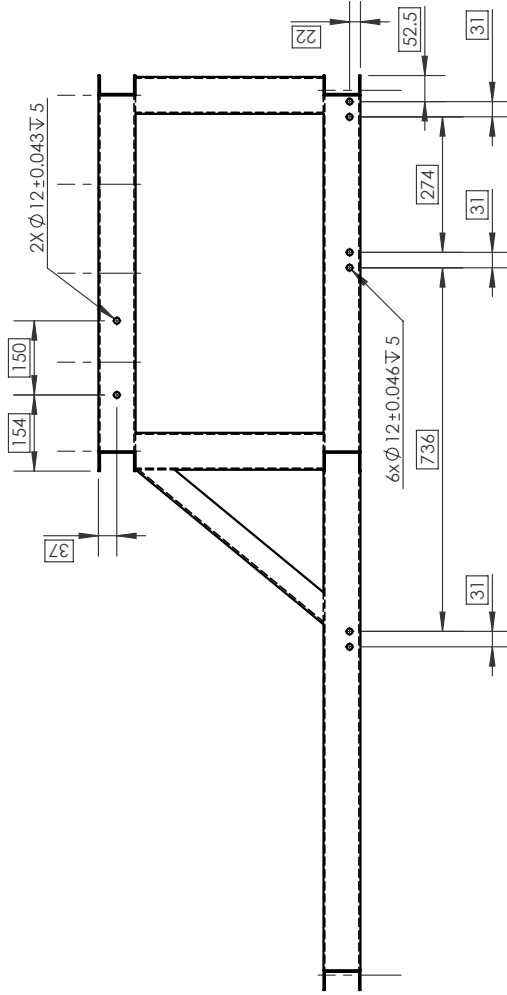
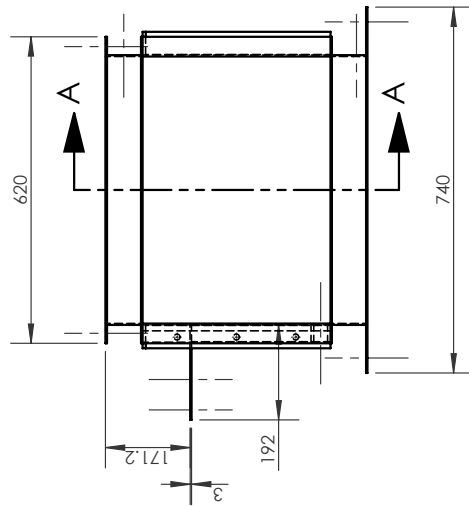

SECTION A-A
 SCALE 1 : 13

N.B: *ONLY TOP VIEW DIMENSIONS HAS SHOWN HERE
 *MODEL IS SYMMETRY FOR BOTTOM HOLES. CHECK SHEET NO 30-33 FOR COMPLETE DRAWINGS.

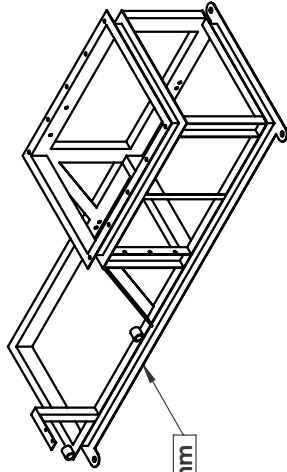

N.B: C-CHANNEL SIZE (75x40x5)mm

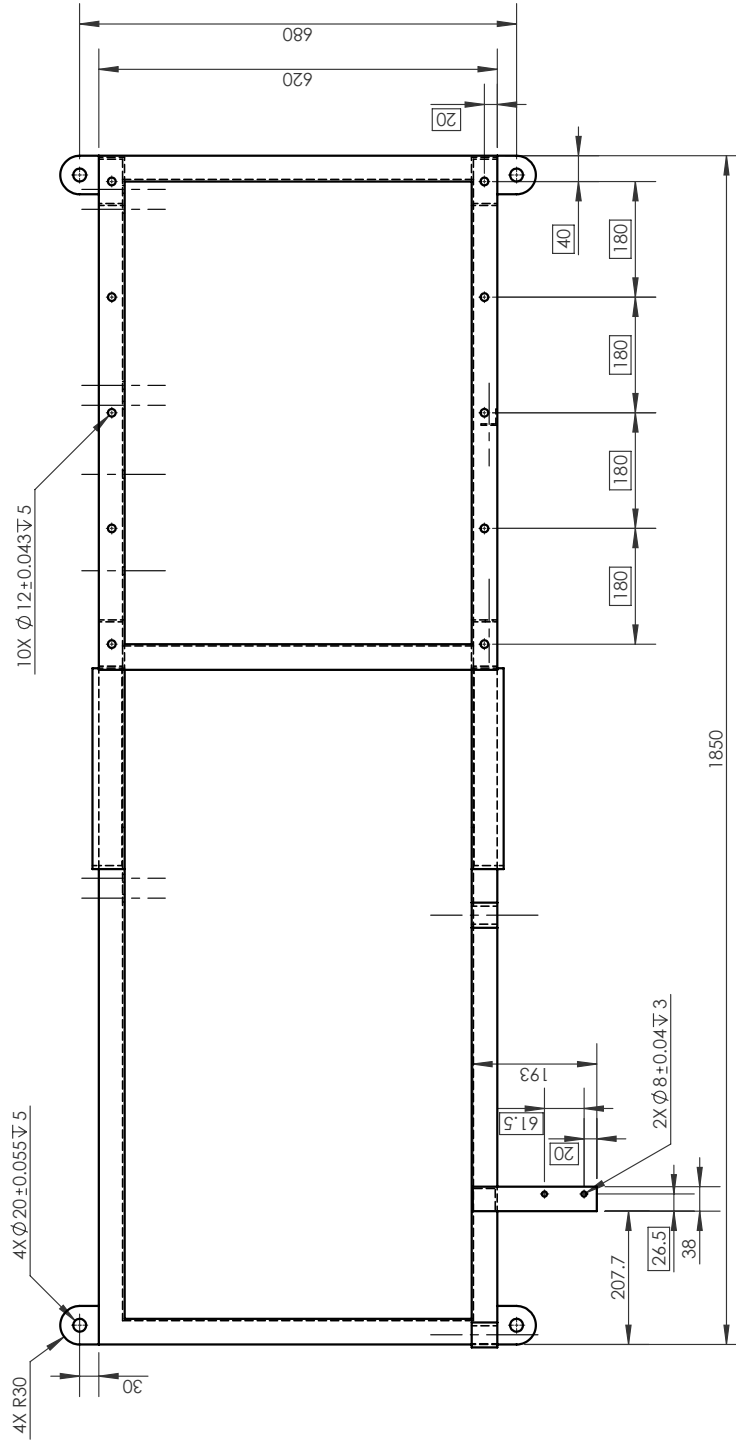

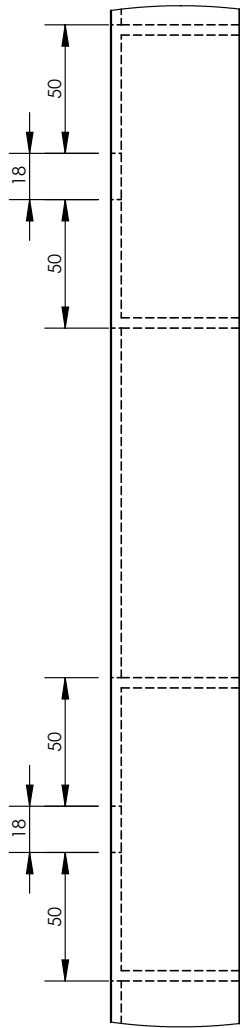

DETAIL A
SCALE 2 : 5

*SIZE 50X50X4 ANGLE BAR.
*ONLY FRONT & RIGHT VIEWS HAS SHOWN HERE.

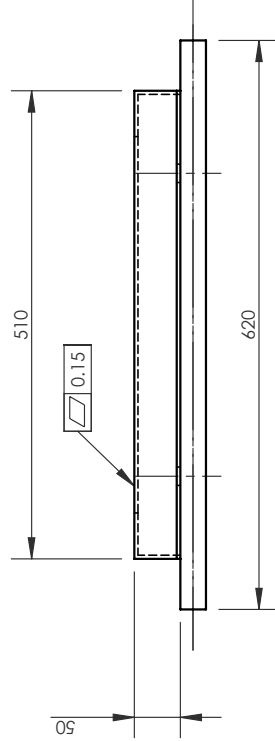
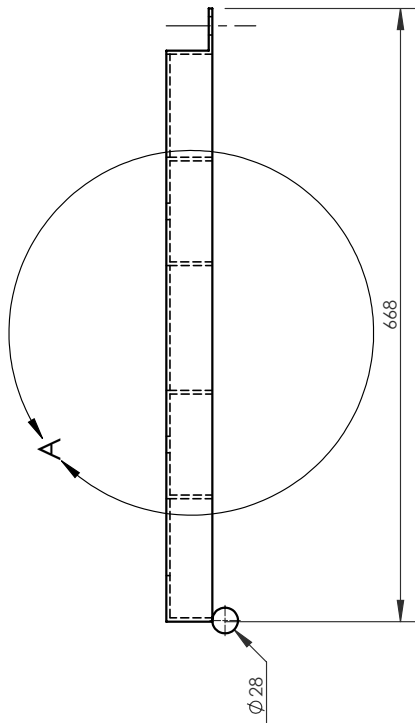
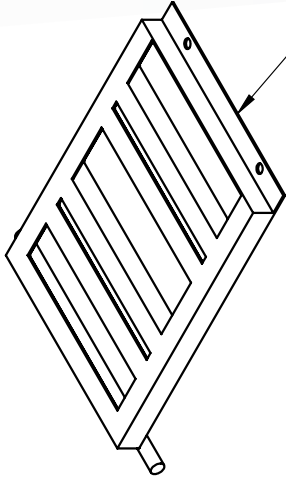

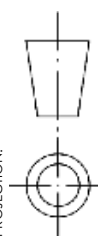
UNLESS OTHERWISE SPECIFIED: STD. TOLERANCE DIMENSIONS ARE IN MILLIMETER MILLIMETER: ± 0.1 , ANGULAR: $\pm 0.05^\circ$ * DOES NOT APPLY TO HOLE SIZE				BANGLADESH RICE RESEARCH INSTITUTE SFMRA PROJECT, FMPHT DIVISION		DO NOT SCALE DRAWING
DETAILS	NAME	SIGNATURE	DATE	TITLE: BRRI COMPACT RICE MILL (BRRI RM2023) DRG. NAME: MOTOR CARRYING BED DWG NO: RM2023_s1-002		FINISH: NONE
DRAWN	ENGR. SHAFER JAHAN KHAN	S J K	01-AUG-2023	DRG. NAME: MOTOR CARRYING BED DWG NO: RM2023_s1-002		FIRST ISSUED: 02-AUG-2023
CHK'D	DR. MD. MOSHARRAF HOSSAIN	M M H	18-DEC-2023	MANUFACTURING METHOD: MACHINING, BENDING & WELDING MATERIAL: Plain Carbon Steel		
APP'D	DR. AKKI SAIBUL ISLAM	A S I	30-DEC-2023	SCALE: 1:14		
THIRD ANGLE PROJECTION:					SHEET 34	
*UPPER AND LOWER LIMIT DEVIATION CHART - H9 *NOTE: DEBURR AND BREAK SHARP EDGES ALL BENDS MIN. RADIUS UNLESS SPECIFIED			WEIGHT: 14987.82 g		REVISION: A	

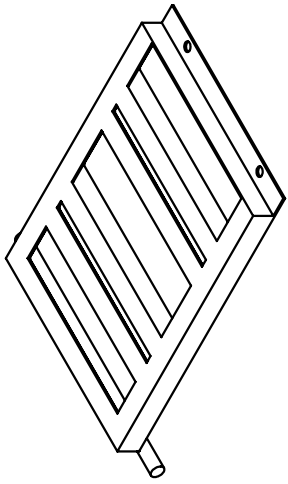

*SIZE 50X50X4 ANGLE BAR
 *ONLY TOP VIEW HAS SHOWN HERE.

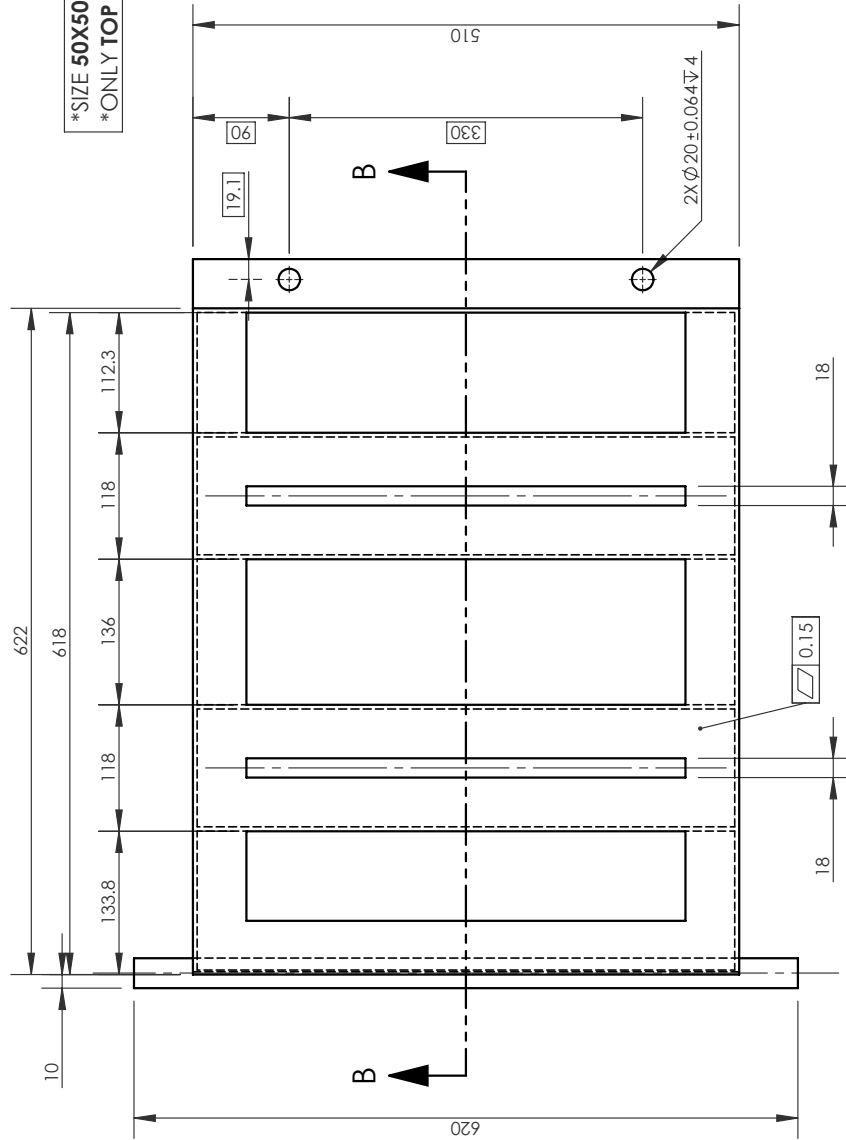
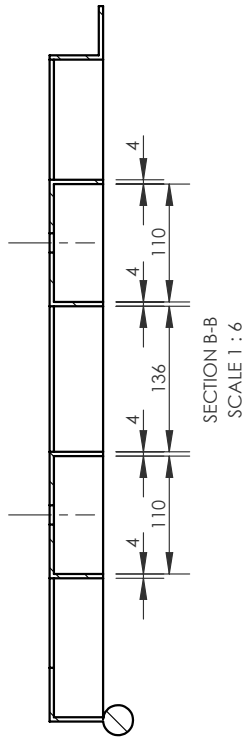

SHEET NO: 35

DRAWING NO: RM2023 S1-002

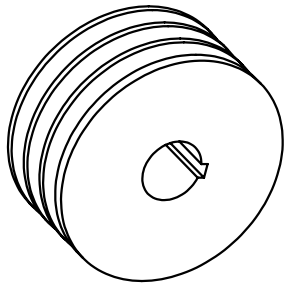

*V-GROOVE PULLEY TYPE-B

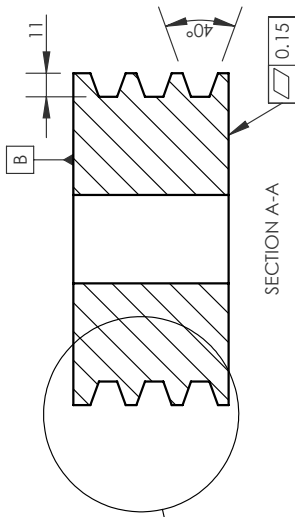

SECTION A-A

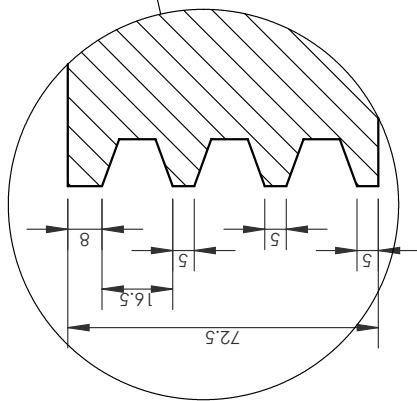

DETAIL B
SCALE 2 : 3

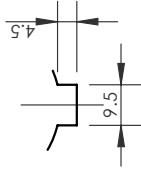
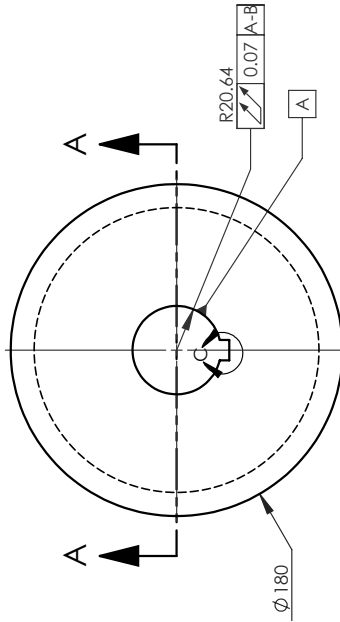

DETAIL C
SCALE 2 : 3

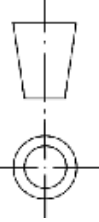
UNLESS OTHERWISE SPECIFIED: STD. TOLERANCE DIMENSIONS ARE IN MILLIMETER MILLIMETER: ±0.1, ANGULAR: ±0.05° * DOES NOT APPLY TO HOLE SIZE				BANGLADESH RICE RESEARCH INSTITUTE SFMRA PROJECT, FMPHT DIVISION		DO NOT SCALE DRAWING
DETAILS		NAME	SIGNATURE	DATE	FINISH: NONE	
DRAWN		ENGR. SHAFER JAHAN RHAN	S J K	01-AUG-2023	FIRST ISSUED: 02-AUG-2023	
CHK'D	DR. MD. MOSHARRAF HOSSAIN	M M H	18-DEC-2023	TITLE: BRRI COMPACT RICE MILL (BRRI RM2023)		
APP'D	DR. AKM SAIBUL ISLAM	A S I	30-DEC-2023	DRG. NAME: BASE MOTOR PULLEY		
THIRD ANGLE PROJECTION:				DWG NO: RM2023_s1-003		
				MANUFACTURING METHOD: MACHINING		
NOTE: DEBURR AND BREAK SHARP EDGES ALL BENDS MIN. RADIUS UNLESS SPECIFIED				MATERIAL: Gray Cast Iron		
SCALE: 1:3				SHEET 36		WEIGHT: 7776.63 g
				REVISION:		A

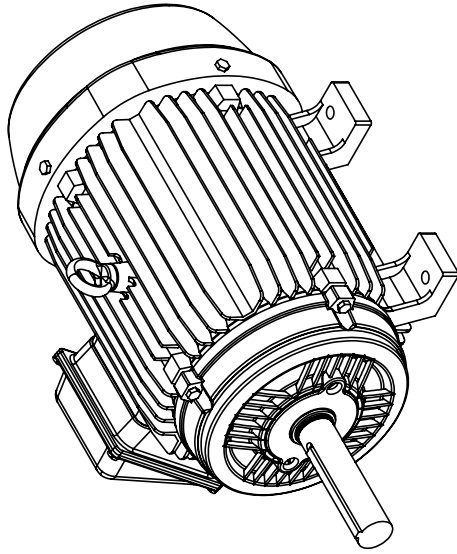

MOTOR: 25HP
 FRAME: 256T
 VOLTAGE: 480V
 Hz: 60Hz
 PHASE: 3
 SHAFT DIAMETER: 41.275mm
 RPM: 1800
 WEIGHT: 104326.24 GRAMS (230 LBS)

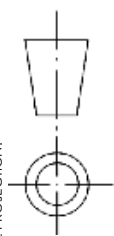
UNLESS OTHERWISE SPECIFIED: STD. TOLERANCE DIMENSIONS ARE IN MILLIMETER MILLIMETER: ±0.1, ANGULAR: ± 0.05° * DOES NOT APPLY TO HOLE SIZE			BANGLADESH RICE RESEARCH INSTITUTE SFMRA PROJECT, FMPHT DIVISION		DO NOT SCALE DRAWING
	DETAILS	NAME	SIGNATURE	DATE	FINISH: NONE
CHK'D	DR. MD. MOSHARRAF HOSSAIN	M. M. H.	18-DEC-2023		FIRST ISSUED: 02-AUG-2023
APP'D	DR. AKM SAIFUL ISLAM	A. S. I.	30-DEC-2023		
THIRD ANGLE PROJECTION:					
					
TITLE: BRRI COMPACT RICE MILL (BRRI RM2023)					
DRG. NAME: ELECTRIC MOTOR-256T-25HP-60HZ-3 PHASE					
DWG NO: RM2023_s1-004					
FINDING PROCESS: SHOP					
MATERIAL: N/A				WEIGHT: g	
SCALE: 1:10				SHEET 37	
				REVISION: A	

NOTE: DEBURR AND BREAK
 SHARP EDGES ALL BENDS MIN.
 RADIUS UNLESS SPECIFIED

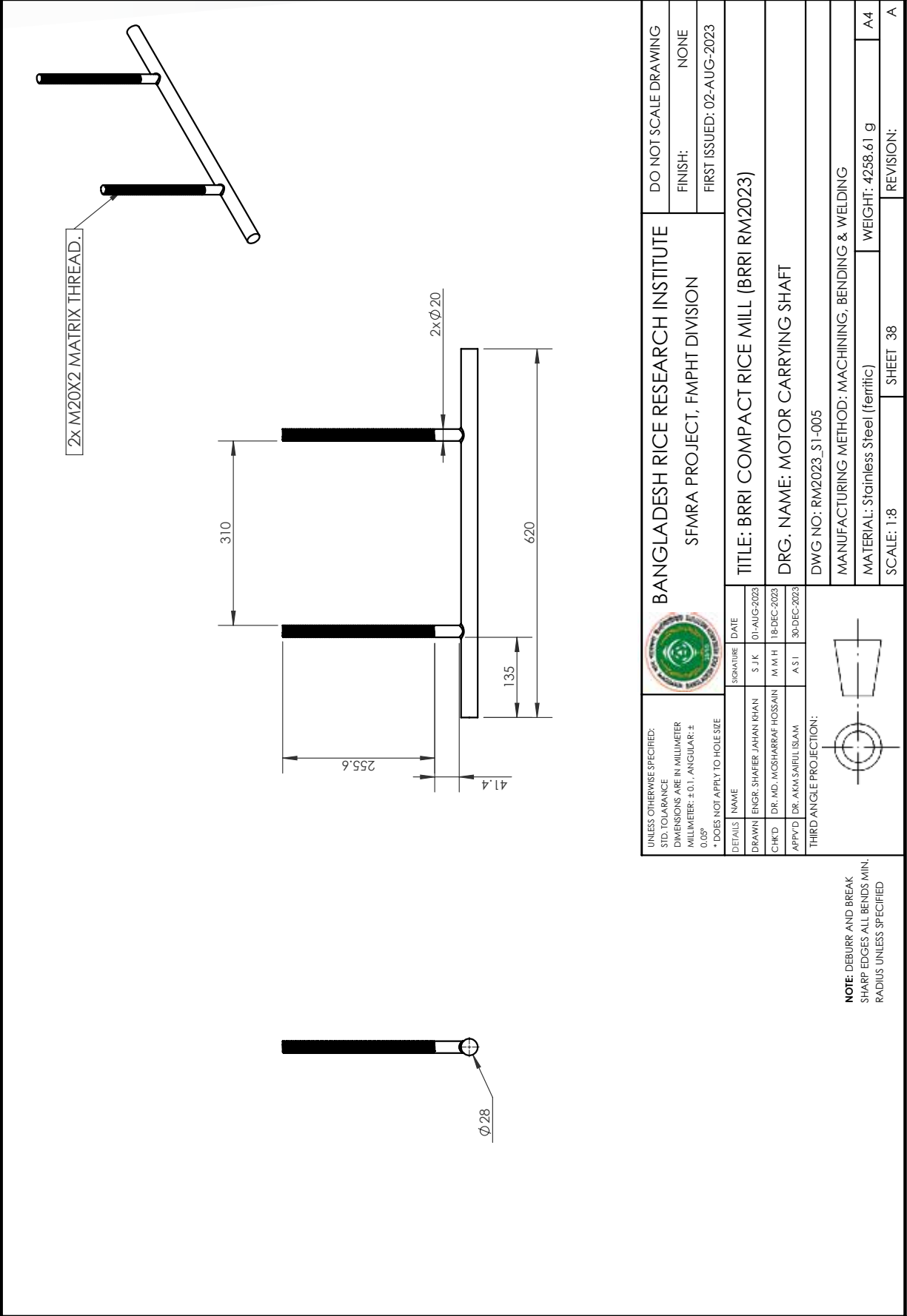

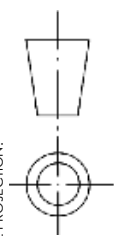
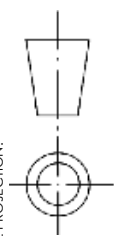
UNLESS OTHERWISE SPECIFIED: STD. TOLERANCE DIMENSIONS ARE IN MILLIMETER MILLIMETER: ±0.1, ANGULAR: ±0.05° * DOES NOT APPLY TO HOLE SIZE				BANGLADESH RICE RESEARCH INSTITUTE SFMPRA PROJECT, FMPHT DIVISION		DO NOT SCALE DRAWING	
DETAILS		NAME	SIGNATURE	DATE	FINISH: NONE		
DRAWN		ENGR. SHAFER JAHAN KHAN	S J K	01-AUG-2023	FIRST ISSUED: 02-AUG-2023		
CHK'D		DR. MD. MOSHARRAF HOSSAIN	M M H	18-DEC-2023	TITLE: BRI COMPACT RICE MILL (BRI RM2023)		
APP'VD		DR. AKM SAIFUL ISLAM	A S I	30-DEC-2023	DRG. NAME: MOTOR CARRYING SHAFT		
THIRD ANGLE PROJECTION:							
				DWG NO: RM2023_s1-005			
MANUFACTURING METHOD: MACHINING, BENDING & WELDING							
MATERIAL: Stainless Steel (ferritic)		WEIGHT: 4258.61 g		REVISION: A			
SCALE: 1:8		SHEET 38		A			

NOTE: DEBURR AND BREAK SHARP EDGES ALL BENDS MIN. RADIUS UNLESS SPECIFIED

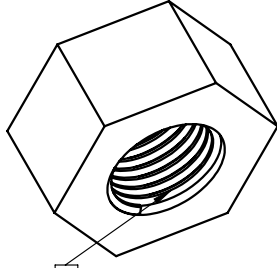

MATRIX THREAD M20x2

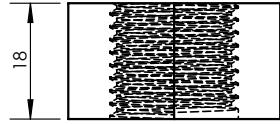

18

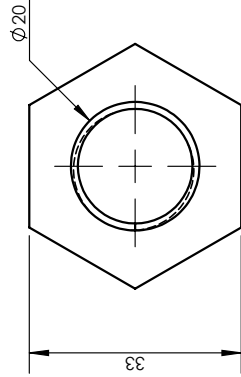

33

$\phi 20$

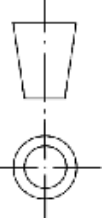
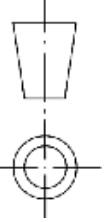
UNLESS OTHERWISE SPECIFIED: STD. TOLERANCE DIMENSIONS ARE IN MILLIMETER MILLIMETER: ± 0.1 , ANGULAR: $\pm 0.05^\circ$ * DOES NOT APPLY TO HOLE SIZE				BANGLADESH RICE RESEARCH INSTITUTE SFMRA PROJECT, FMPHT DIVISION		DO NOT SCALE DRAWING	
DETAILS		NAME	SIGNATURE	DATE	FINISH: NONE		
DRAWN		ENGR. SHAFER JAHAN RHAN	S. J.K	01-AUG-2023	FIRST ISSUED: 02-AUG-2023		
CHK'D		DR. MD. MOSHARRAF HOSSAIN	M. M.H	18-DEC-2023	TITLE: BRRI COMPACT RICE MILL (BRRI RM2023)		
APP'VD		DR. AKM SAIFUL ISLAM	A.S.I	30-DEC-2023	DRG. NAME: HEX NUT_M20 x 2.50 x 18		
THIRD ANGLE PROJECTION:				DWG NO: RM2023_s1-006			
NOTE: DEBURR AND BREAK SHARP EDGES ALL BENDS MIN. RADIUS UNLESS SPECIFIED				MANUFACTURING METHOD: MACHINING, BENDING & WELDING			
				MATERIAL: Stainless Steel (ferritic)		WEIGHT: 93.17 g	
				SCALE: 1:1		SHEET: 39	
						REVISION: A	

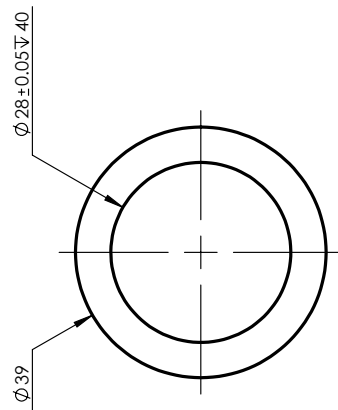
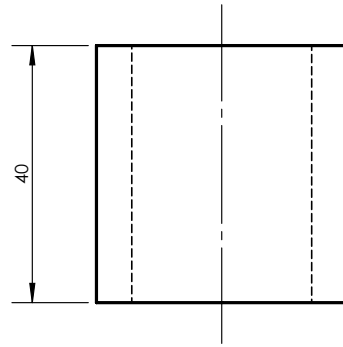
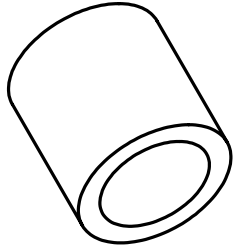

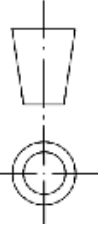
UNLESS OTHERWISE SPECIFIED: STD. TOLERANCE DIMENSIONS ARE IN MILLIMETER MILLIMETER: ± 0.1 , ANGULAR: $\pm 0.05^\circ$ * DOES NOT APPLY TO HOLE SIZE				BANGLADESH RICE RESEARCH INSTITUTE SFMRA PROJECT, FMPHT DIVISION		DO NOT SCALE DRAWING	
DETAILS		NAME	SIGNATURE	DATE	TITLE: BRRI COMPACT RICE MILL (BRRI RM2023)		
DRAWN	ENGR. SHAFER JAHAN RHAN	S. J.K	[Signature]	01-AUG-2023	FINISH: NONE		
CHK'D	DR. MD. MOSHARRAF HOSSAIN	M. M.H	[Signature]	18-DEC-2023	FIRST ISSUED: 02-AUG-2023		
APP'D	DR. AKM SAIFUL ISLAM	A. S.I	[Signature]	30-DEC-2023	DRG. NAME: MOTOR CARRYING BED PART		
THIRD ANGLE PROJECTION:							
NOTE: DEBURR AND BREAK SHARP EDGES ALL BENDS MIN. RADIUS UNLESS SPECIFIED				DWG NO: RM2023_s1-007			
MANUFACTURING METHOD: MACHINING				SCALE: 1:1			
MATERIAL: Plain Carbon Steel				SHEET: 40		REVISION: A	
WEIGHT: 180.60 g				A4		A	

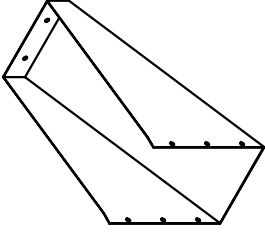
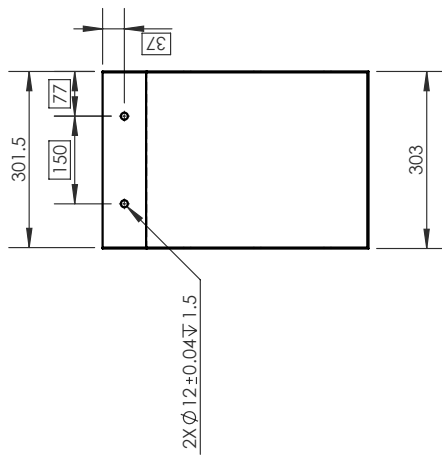
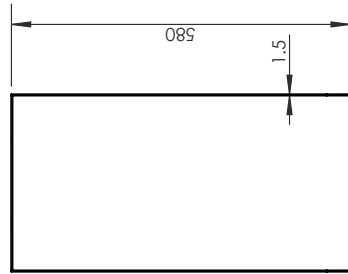

N.B. SHEET THICKNESS 1.5mm.
*BENDING RADIUS 2mm.

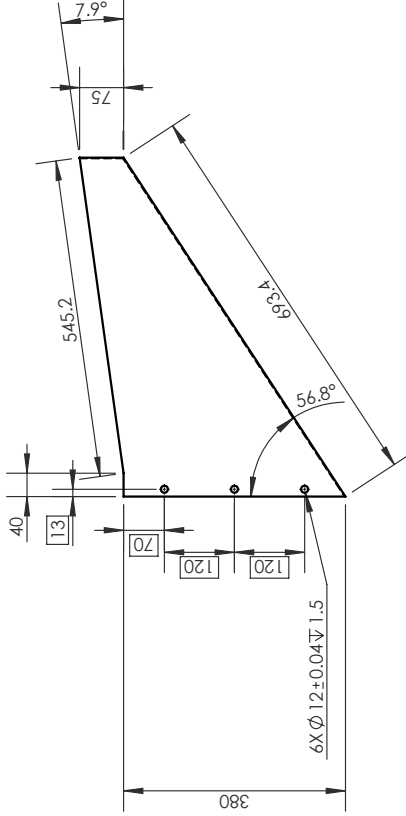

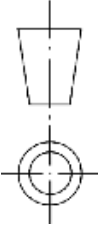
UNLESS OTHERWISE SPECIFIED: STD. TOLERANCE DIMENSIONS ARE IN MILLIMETER MILLIMETER: ±0.1, ANGULAR: ± 0.05° * DOES NOT APPLY TO HOLE SIZE				BANGLADESH RICE RESEARCH INSTITUTE SFMRA PROJECT, FMPHT DIVISION		DO NOT SCALE DRAWING	
DETAILS	NAME	SIGNATURE	DATE	TITLE: BRRI COMPACT RICE MILL (BRRI RM2023) DRG. NAME: HUSK OUT-LINE		FINISH: NONE	
DRAWN	ENGR. SHAFER JAHAN KHAN	S J K	01-AUG-2023	DWG NO: RM2023_s1-008 MANUFACTURING METHOD: MACHINING, BENDING & WELDING		FIRST ISSUED: 02-AUG-2023	
CHK'D	DR. MD. MOSHARRAF HOSSAIN	M M H	18-DEC-2023	DRG. NAME: HUSK OUT-LINE DWG NO: RM2023_s1-008		REVISION: A WEIGHT: 5734.45 g	
APP'D	DR. AKM SAIBUL ISLAM	A S I	30-DEC-2023	THIRD ANGLE PROJECTION: 		SCALE: 1:1 SHEET 41	
NOTE: DEBURR AND BREAK SHARP EDGES ALL BENDS MIN. RADIUS UNLESS SPECIFIED				MANUFACTURING METHOD: MACHINING, BENDING & WELDING MATERIAL: Plain Carbon Steel		REVISION: A WEIGHT: 5734.45 g	

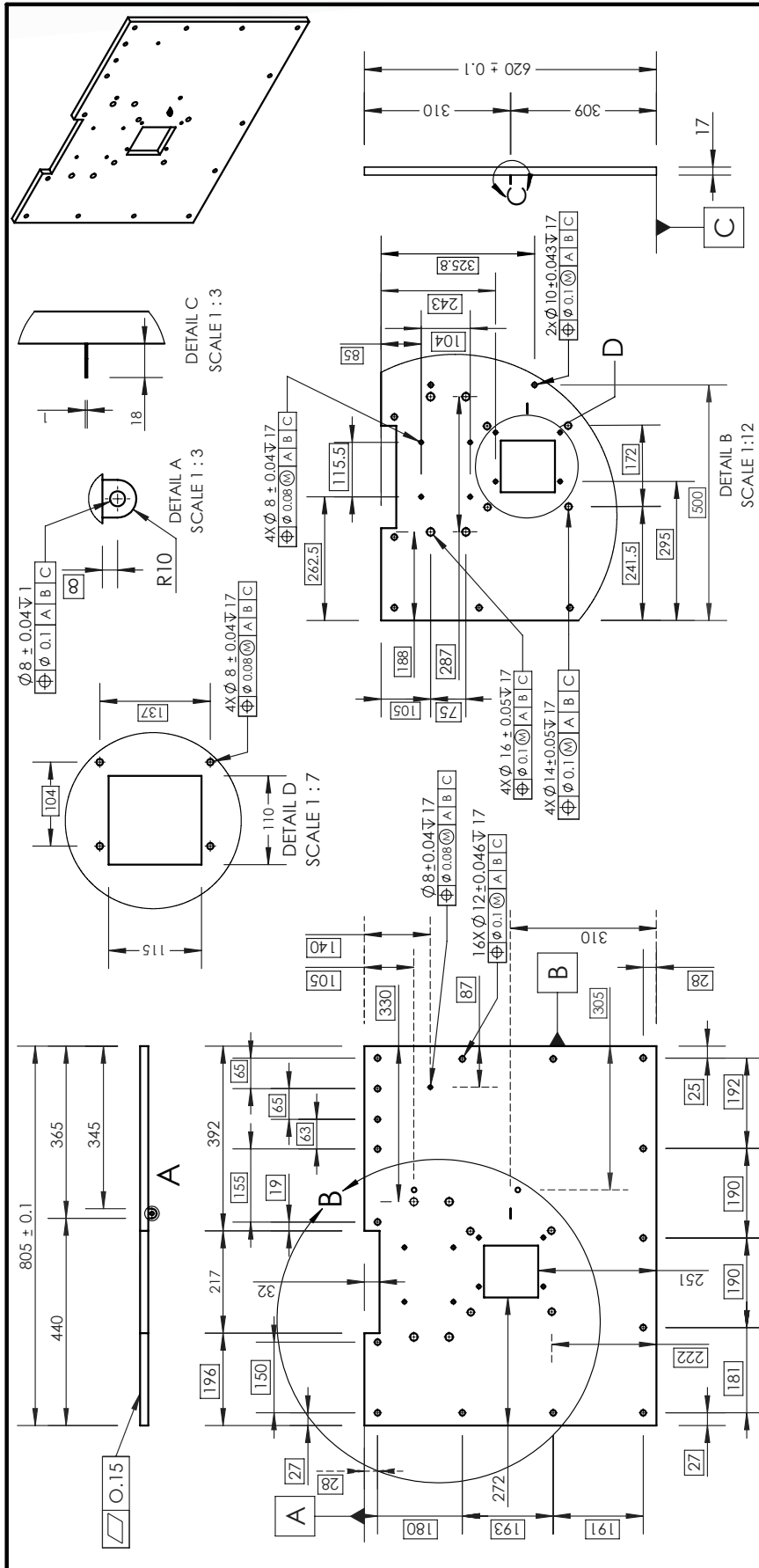

<p>UNLESS OTHERWISE SPECIFIED: STD. TOLERANCE DIMENSIONS ARE IN MILLIMETER MILLIMETER: ±0.1, ANGULAR: ± 0.05° * DOES NOT APPLY TO HOLE SIZE</p>		<p>DO NOT SCALE DRAWING</p>	
<p>FINISH: NONE</p>		<p>FIRST ISSUED: 02-AUG-2023</p>	
<p>BANGLADESH RICE RESEARCH INSTITUTE SFMRA PROJECT, FMPHT DIVISION</p>			
<p>TITLE: BRRI COMPACT RICE MILL (BRRI RM2023)</p>			
<p>DRG. NAME: UPPER HOLDING PART</p>			
<p>DWG NO: RM2023_S2-009</p>			
<p>MANUFACTURING METHOD: MACHINING</p>			
<p>MATERIAL: Plain Carbon Steel</p>			
<p>SCALE: 1:12</p>			
<p>SHEET 42</p>			
<p>REVISION: A</p>			
<p>WEIGHT: 63077.92 g</p>		<p>A4</p>	

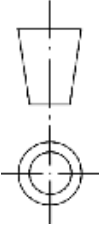
		<p>THIRD ANGLE PROJECTION:</p> 	
<p>UNLESS OTHERWISE SPECIFIED: STD. TOLERANCE DIMENSIONS ARE IN MILLIMETER MILLIMETER: ±0.1, ANGULAR: ± 0.05° * DOES NOT APPLY TO HOLE SIZE</p>	<p>DETAILS NAME</p>	<p>SIGNATURE</p>	<p>DATE</p>
<p>CHK'D DR. MD. MOSHARRAF HOSSAIN</p>	<p>DRAWN ENGR. SHAFER JAHAN RHAN</p>	<p>S J K</p>	<p>07-AUG-2023</p>
<p>APP'VD DR. AKM SAIBUL ISLAM</p>	<p>M M H</p>	<p>A S I</p>	<p>18-DEC-2023</p>
<p>30-DEC-2023</p>			

N.B. 16 HOLES AT THE BORDER

UPPER AND LOWER LIMIT DEVIATION CHART - H9

NOTE: DEBURR AND BREAK SHARP EDGES ALL BENDS MIN. RADIUS UNLESS SPECIFIED

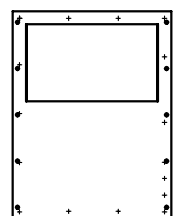
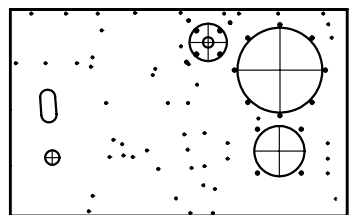
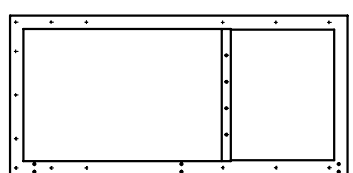
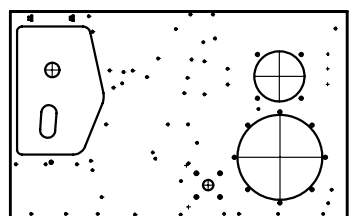
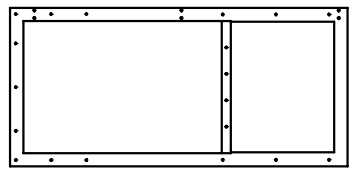
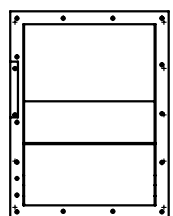
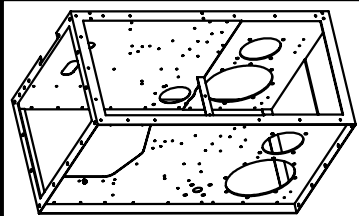

N.B.: THICKNESS OF THE SHEET-METAL IS 2mm.
 *UPPER AND LOWER LIMIT DEVIATION CHART - H9
 **IN BOTTOM OF THE BODY ANOTHER 3mm METAL SHEET IS USED TO MAKE THE BODY MORE PHYSICALLY STRENGTH. THE POLISHER ASSEMBLY WILL MATE HERE. SO IN BOTTOM 2+3=5mm SIZE. CHECK THE INSPECTION DIMENSION IN THE PAGE. (MUST MAINTAIN 5MM HERE OR PARTS WILL NOT FIT.)



BANGLADESH RICE RESEARCH INSTITUTE
 SFMRA PROJECT, FMPHT DIVISION

TITLE: BRRI COMPACT RICE MILL (BRRI RM2023)

DRG. NAME: MACHINE SHELL

DWG NO: RM2023_s2-010

MANUFACTURING METHOD: MACHINING, BENDING & WELDING

MATERIAL: Plain Carbon Steel

WEIGHT: 57743.29 g

SCALE: 1:20 SHEET 43

REVISION: A

DO NOT SCALE DRAWING
 FINISH: NONE
 FIRST ISSUED: 02-AUG-2023

UNLESS OTHERWISE SPECIFIED:
 STD. TOLERANCE DIMENSIONS ARE IN MILLIMETER
 MILLIMETER: ±0.1, ANGULAR: ±0.05°
 * DOES NOT APPLY TO HOLE SIZE

DETAILS	NAME	SIGNATURE	DATE
DRAWN	ENGR. SHAFER JAHAN KHAN	S J K	07-AUG-2023
CHK'D	DR. MD. MOSHARRAF HOSSAIN	M M H	18-DEC-2023
APP'D	DR. AKKI SAIBUL ISLAM	A S I	30-DEC-2023

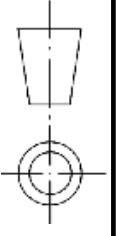

NOTE: DEBURR AND BREAK SHARP EDGES ALL BENDS MIN. RADIUS UNLESS SPECIFIED

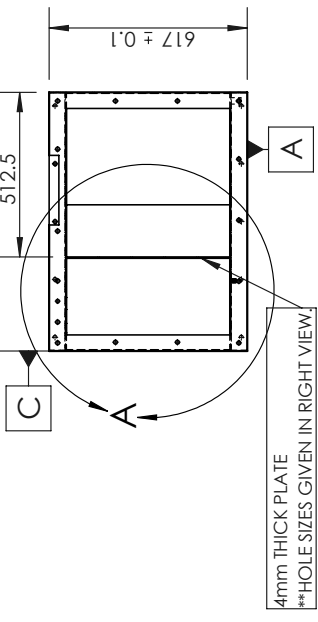
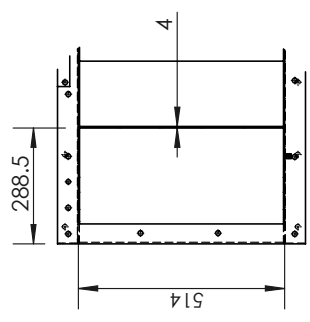
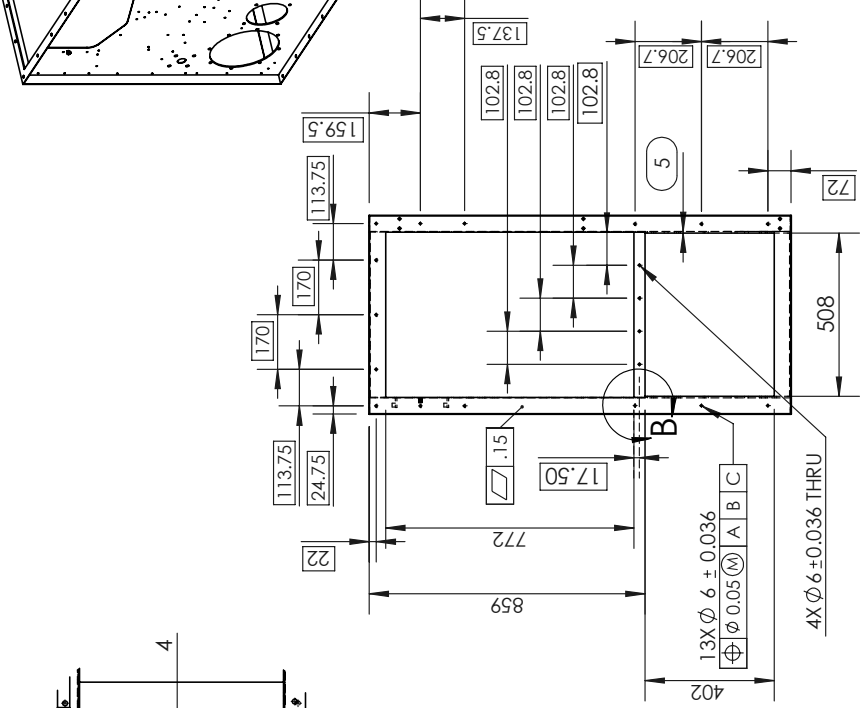
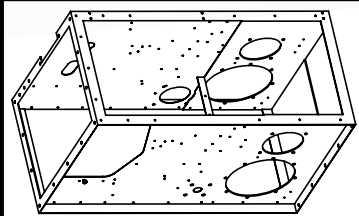

DETAIL A
SCALE 1 : 16

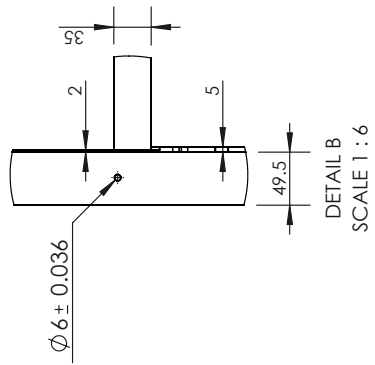
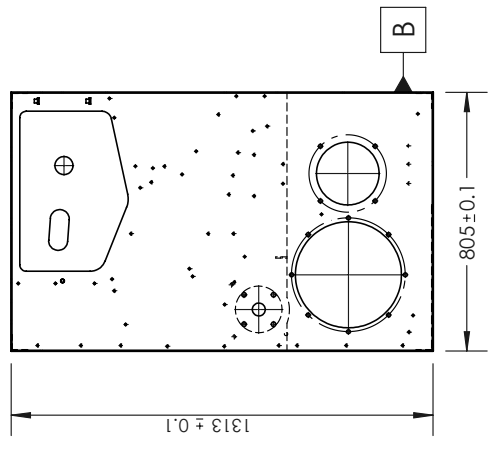

N.B. NOT A COMPLETE DRAWING.
 NOTE-A: ONLY RIGHT & TOP SIDE DIMENSIONS IS SHOWING HERE.
 SYMMETRY SIZES ARE APPLIED FOR BORDER HOLES.
 N.B: THICKNESS OF THE SHEET-METAL IS 2mm.

*UPPER AND LOWER LIMIT DEVIATION CHART - H9
 **IN BOTTOM OF THE BODY ANOTHER 3mm METAL SHEET IS USED TO MAKE THE BODY MORE PHYSICALLY STRENGTH. THE POLISHER ASSEMBLY WILL MATE HERE. SO IN BOTTOM 2+3=5mm SIZE. CHECK THE INSPECTION DIMENSION IN THE PAGE. (MUST MAINTAIN 5MM HERE OR PARTS WILL NOT FIT.)

DWG NO: RM2023_S2-010
 SHEET NO: 44

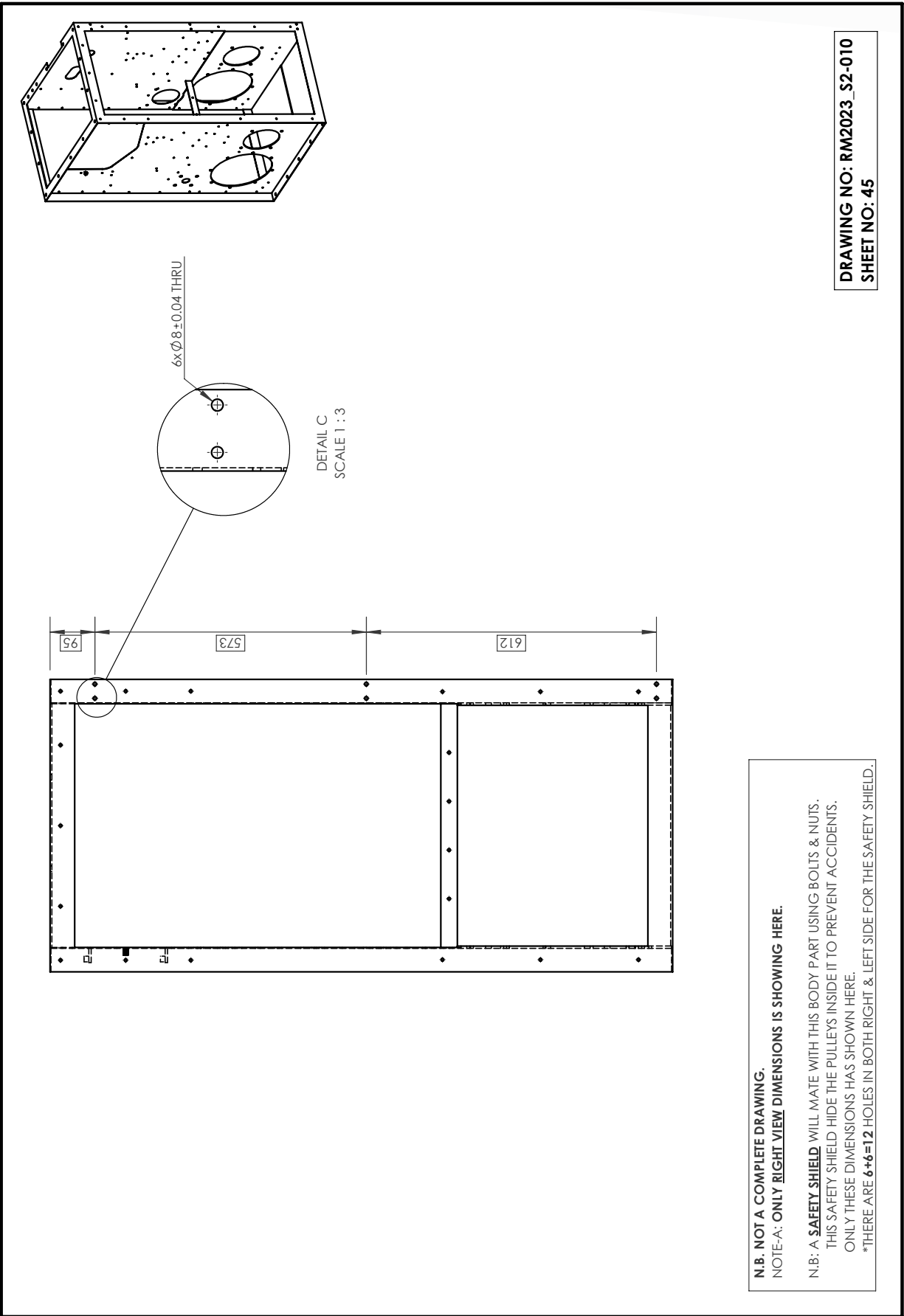

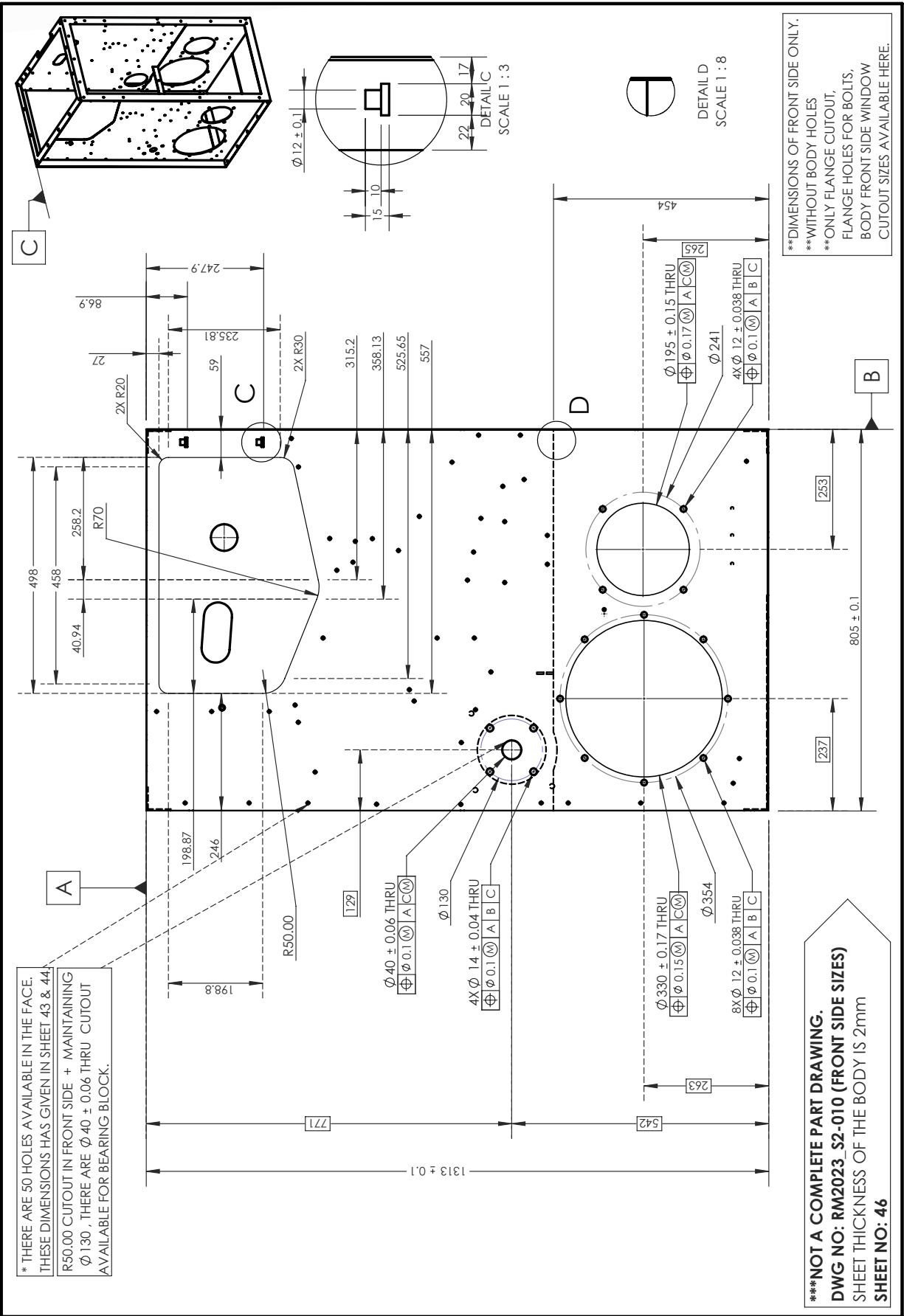

* THERE ARE 50 HOLES AVAILABLE IN THE FACE. THESE DIMENSIONS HAS GIVEN IN SHEET 43 & 44!
 R50.00 CUTOUT IN FRONT SIDE + MAINTAINING $\phi 130$, THERE ARE $\phi 40 \pm 0.06$ THRU CUTOUT AVAILABLE FOR BEARING BLOCK.

***NOT A COMPLETE PART DRAWING.
 DWG NO: RM2023_S2-010 (FRONT SIDE SIZES)
 SHEET THICKNESS OF THE BODY IS 2mm
 SHEET NO: 46

**DIMENSIONS OF FRONT SIDE ONLY.
 **WITHOUT BODY HOLES
 **ONLY FLANGE CUTOUT, FLANGE HOLES FOR BOLTS, BODY FRONT SIDE WINDOW CUTOUT SIZES AVAILABLE HERE.

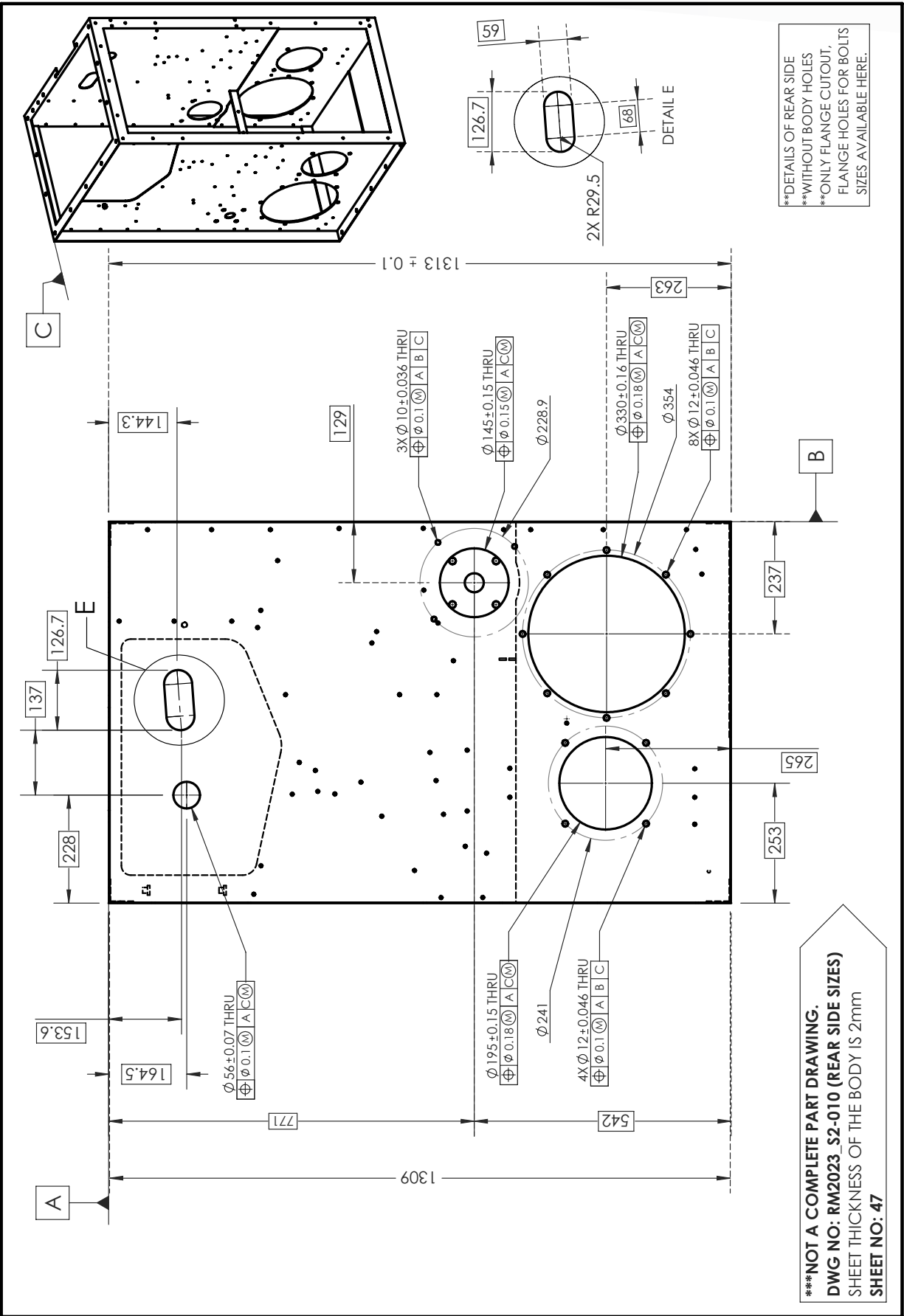

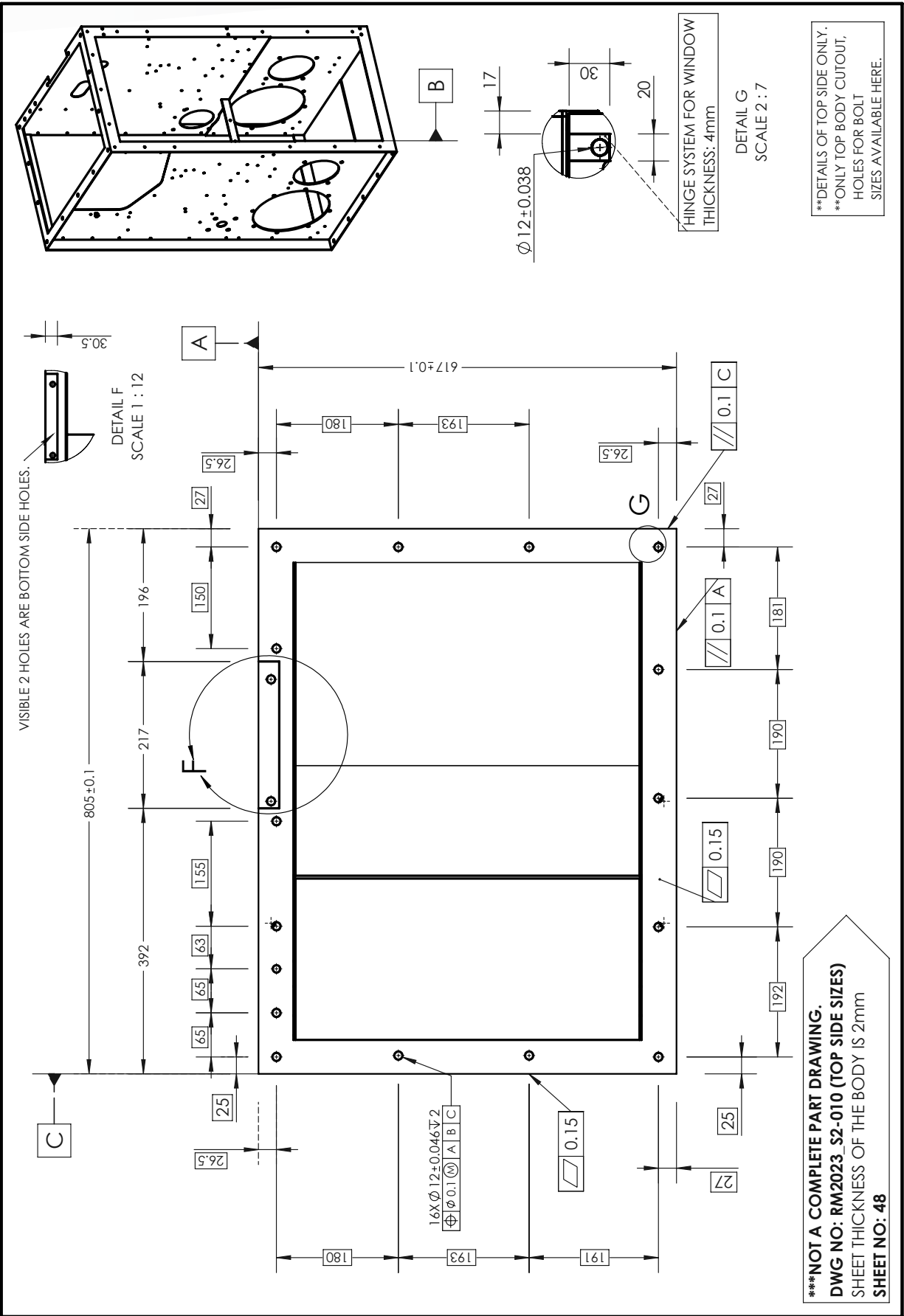

**DETAILS OF TOP SIDE ONLY.
**ONLY TOP BODY CUTOUT,
HOLES FOR BOLT
SIZES AVAILABLE HERE.

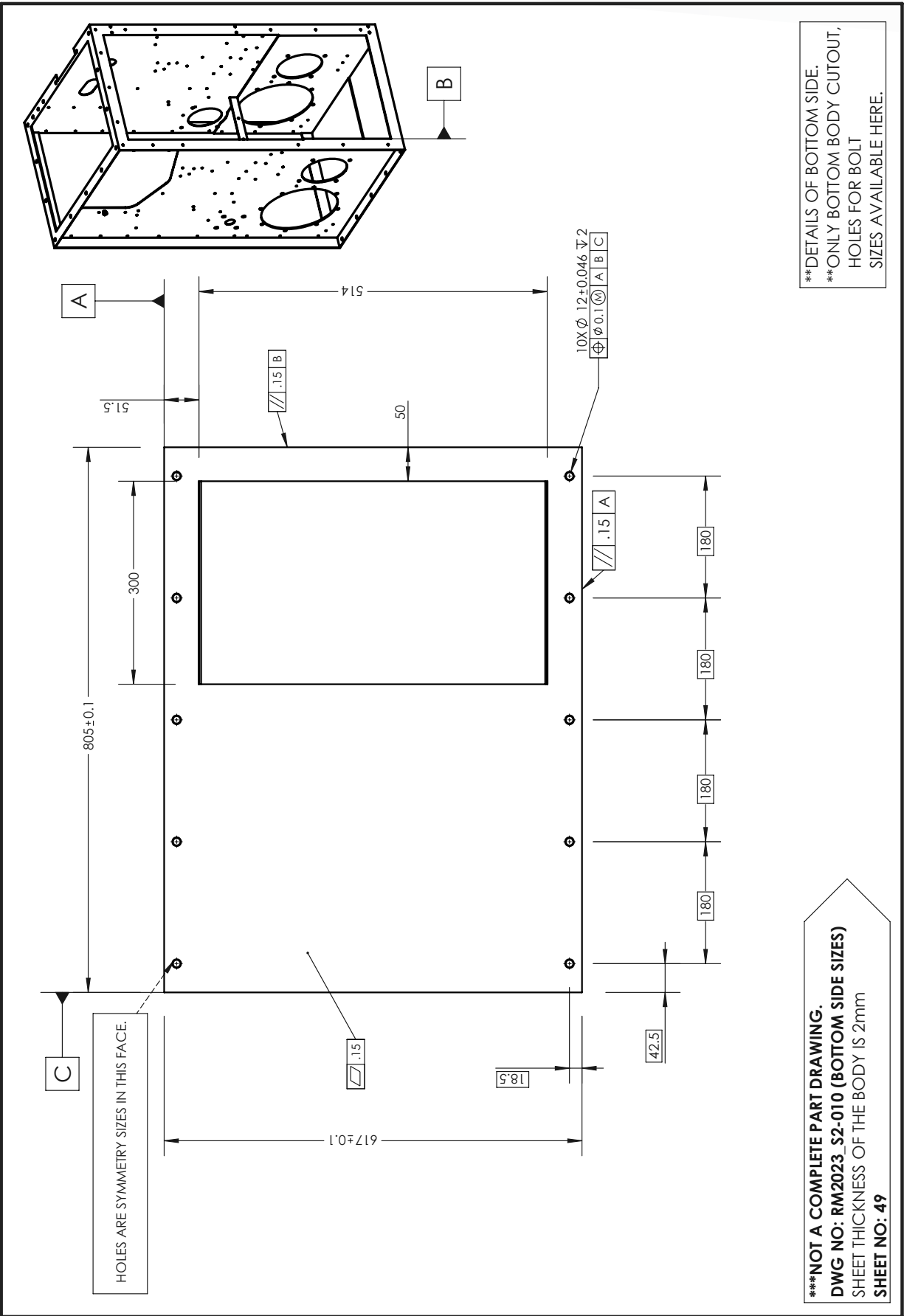

HOLES ARE SYMMETRY SIZES IN THIS FACE.

**DETAILS OF BOTTOM SIDE.
 **ONLY BOTTOM BODY CUTOUT,
 HOLES FOR BOLT
 SIZES AVAILABLE HERE.

***NOT A COMPLETE PART DRAWING.
 DWG NO: RM2023_S2-010 (BOTTOM SIDE SIZES)
 SHEET THICKNESS OF THE BODY IS 2mm
 SHEET NO: 49

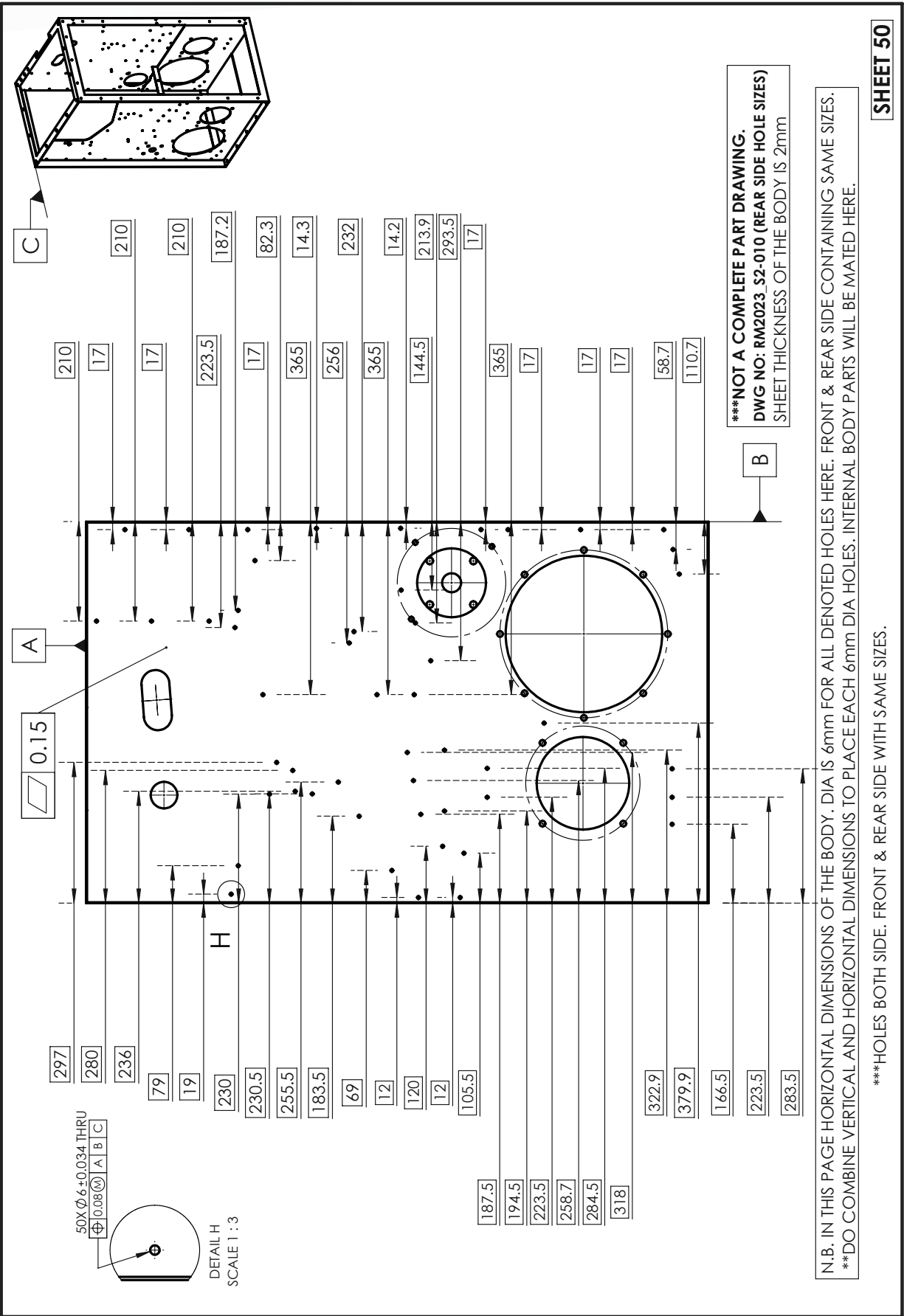

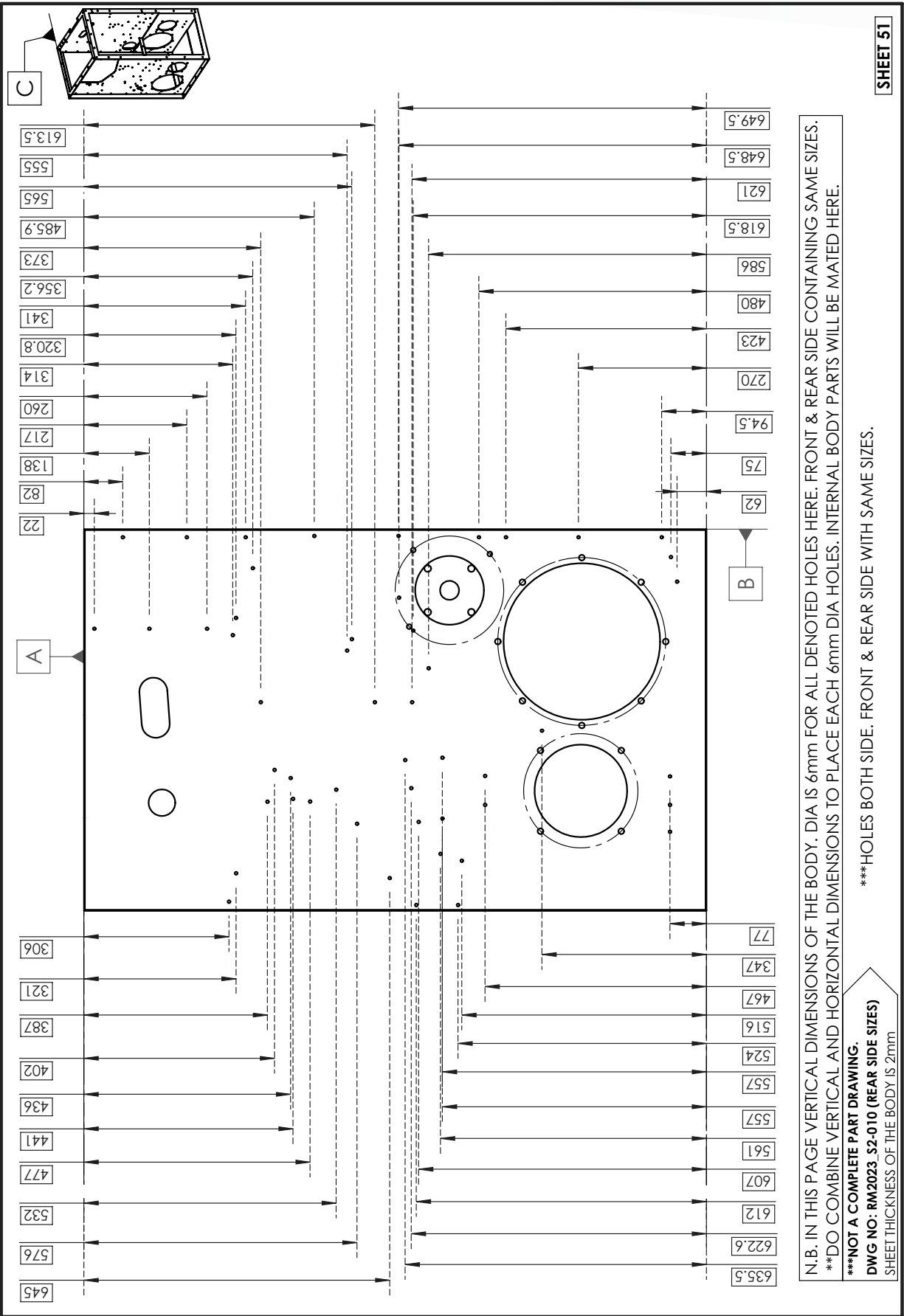



N.B. IN THIS PAGE VERTICAL DIMENSIONS OF THE BODY. DIA IS 6mm FOR ALL DENOTED HOLES HERE. FRONT & REAR SIDE CONTAINING SAME SIZES.
 **DO COMBINE VERTICAL AND HORIZONTAL DIMENSIONS TO PLACE EACH 6mm DIA HOLES. INTERNAL BODY PARTS WILL BE MATED HERE.

***NOT A COMPLETE PART DRAWING.
 DWG NO: RM2023 S2-010 (REAR SIDE SIZES)
 SHEET THICKNESS OF THE BODY IS 2mm

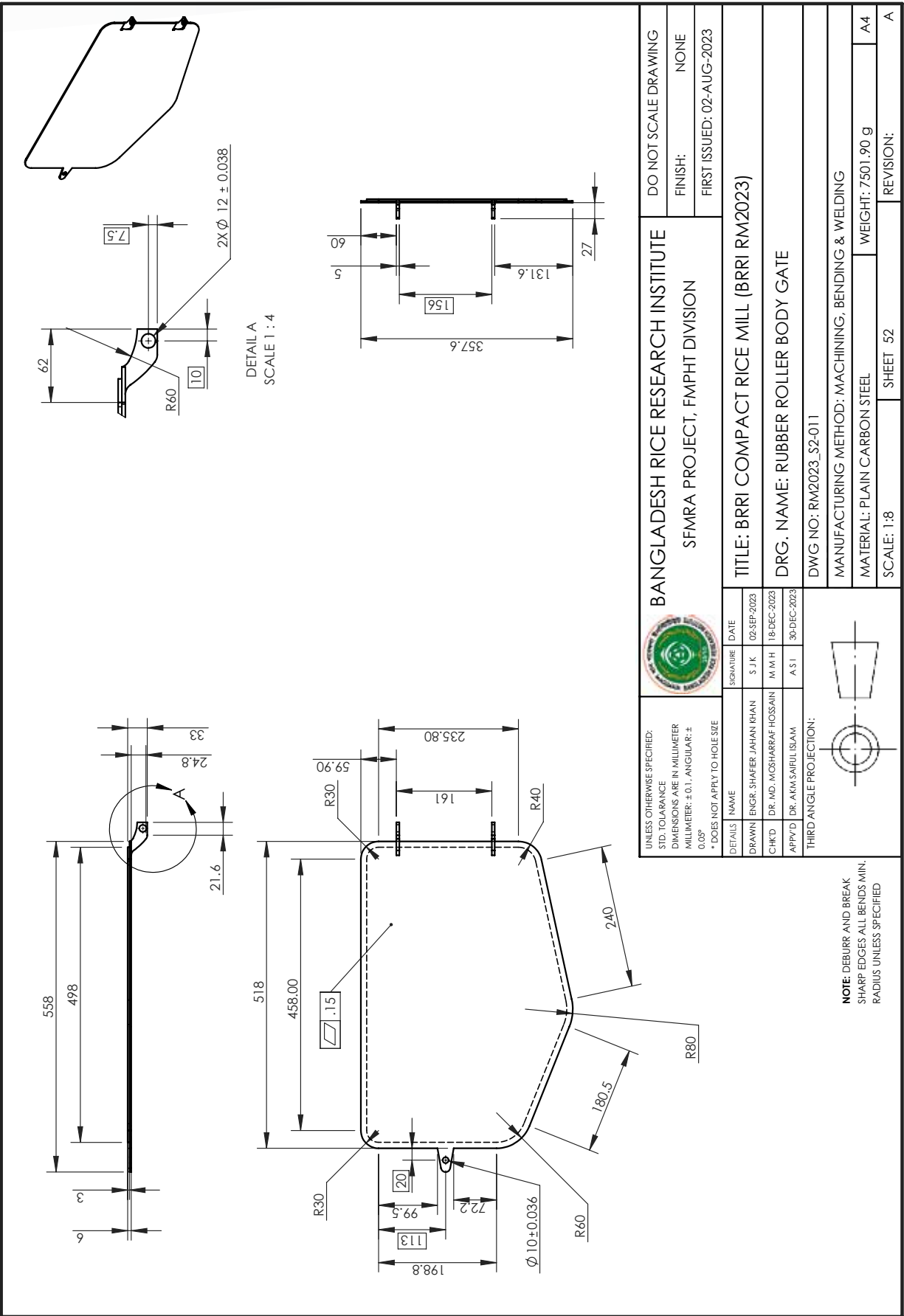
SHEET 51

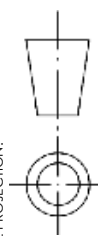

		BANGLADESH RICE RESEARCH INSTITUTE SFMRA PROJECT, FMPHT DIVISION		DO NOT SCALE DRAWING
UNLESS OTHERWISE SPECIFIED: STD. TOLERANCE DIMENSIONS ARE IN MILLIMETER MILLIMETER: ±0.1, ANGULAR: ±0.05° * DOES NOT APPLY TO HOLE SIZE		SIGNATURE S. J.K.	DATE 02-SEP-2023	FINISH: NONE
DRAWN ENGR. SHAFER JAHAN KHAN	M. M. H.	18-DEC-2023	FIRST ISSUED: 02-AUG-2023	
CHKD DR. MD. MOSHARRAF HOSSAIN	A. S. I.	30-DEC-2023	TITLE: BRII COMPACT RICE MILL (BRII RM2023)	
THIRDS ANGLE PROJECTION: 			DRG. NAME: RUBBER ROLLER BODY GATE	
NOTE: DEBURR AND BREAK SHARP EDGES ALL BENDS MIN. RADIUS UNLESS SPECIFIED			DWG NO: RM2023_S2-011	
MANUFACTURING METHOD: MACHINING, BENDING & WELDING			MATERIAL: PLAIN CARBON STEEL	
SCALE: 1:8			SHEET: 52	REVISION: A
WEIGHT: 7501.90 g			A4	

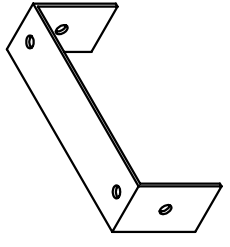
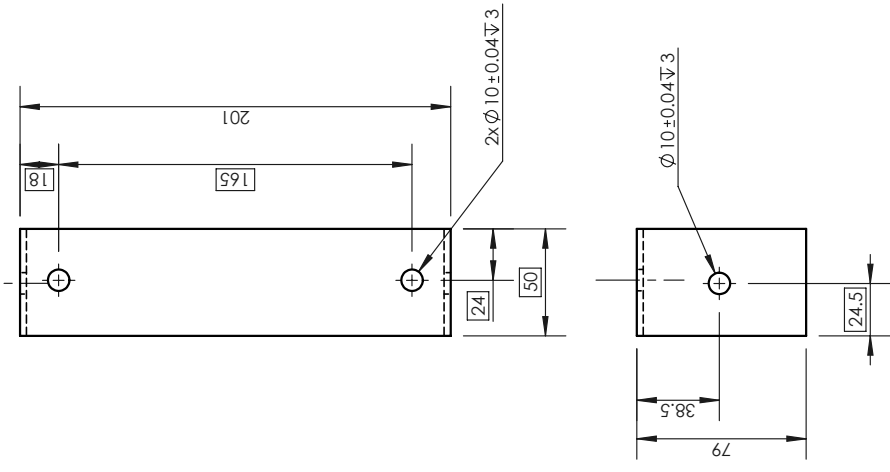

*MODEL IS SYMMETRY.
ONE SIDE DIMENSIONS HAS SHOWN HERE.

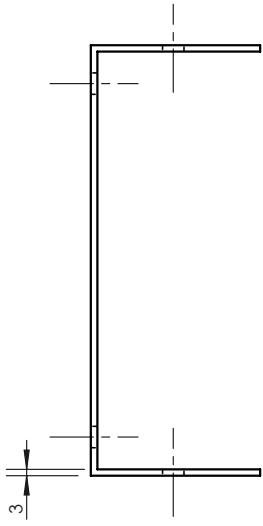

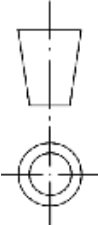
UNLESS OTHERWISE SPECIFIED: STD. TOLERANCE DIMENSIONS ARE IN MILLIMETER MILLIMETER: ±0.1, ANGULAR: ±0.05° * DOES NOT APPLY TO HOLE SIZE				BANGLADESH RICE RESEARCH INSTITUTE SFMRA PROJECT, FMPHT DIVISION		DO NOT SCALE DRAWING	
DETAILS	NAME	SIGNATURE	DATE	FINISH: NONE			
	ENGR. SHAFER JAHAN RHAN	S J K	07-AUG-2023	FIRST ISSUED: 02-AUG-2023			
CHK'D	DR. MD. MOSHARRAF HOSSAIN	M M H	18-DEC-2023	TITLE: BRRI COMPACT RICE MILL (BRRI RM2023)			
APP'VD	DR. AKM SAIBUL ISLAM	A S I	30-DEC-2023	DRG. NAME: BODY SHELL OUTER PART			
THIRD ANGLE PROJECTION:				DWG NO: RM2023_s2-012			
				MANUFACTURING METHOD: MACHINING, BENDING			
NOTE: DEBURR AND BREAK SHARP EDGES ALL BENDS MIN. RADIUS UNLESS SPECIFIED				MATERIAL: ASTM A36 Steel			
				SCALE: 1:5		WEIGHT: 408.26 g	
				SHEET 53		REVISION: A	

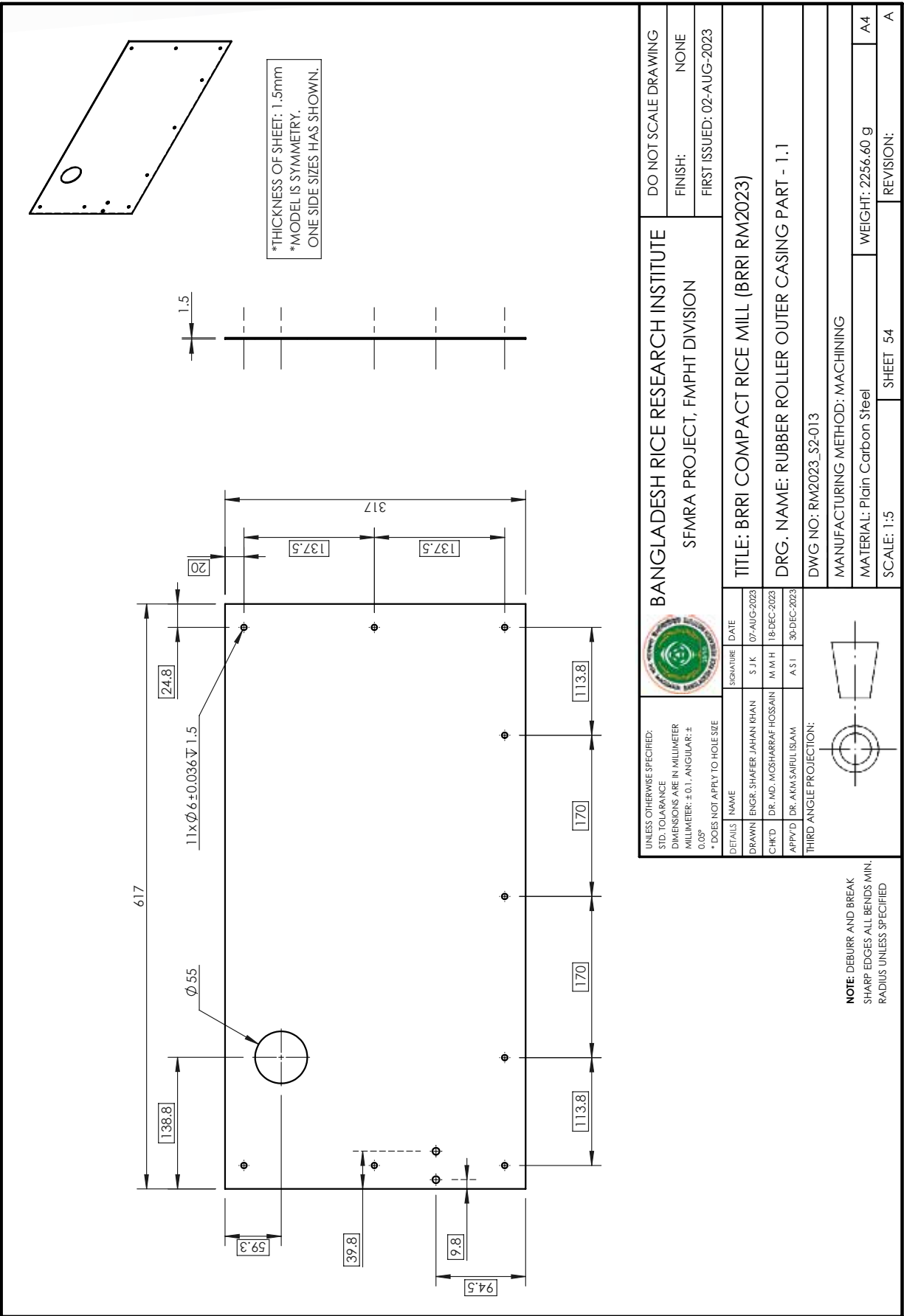

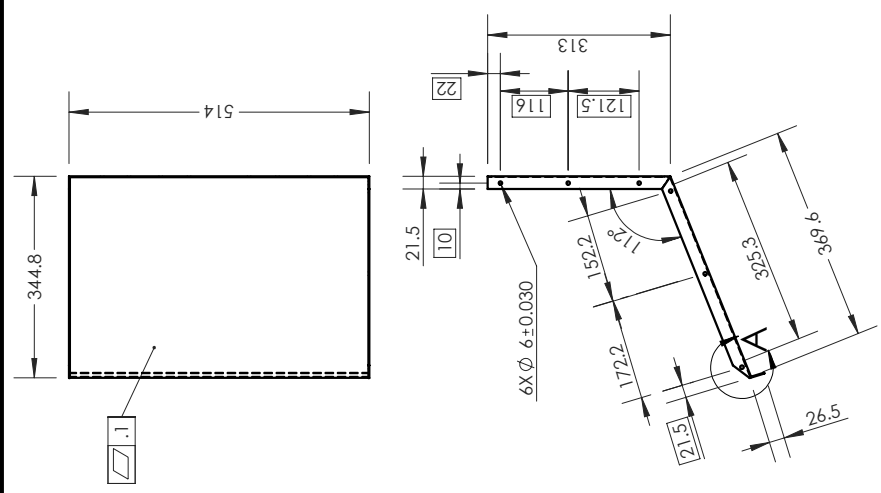
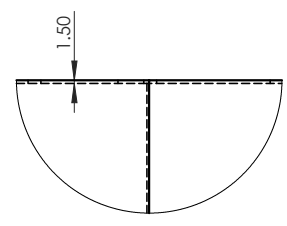
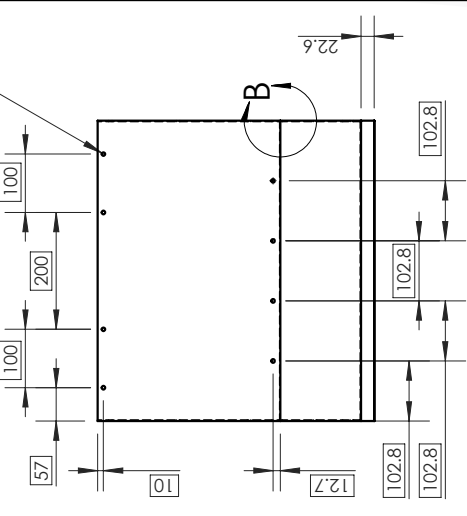
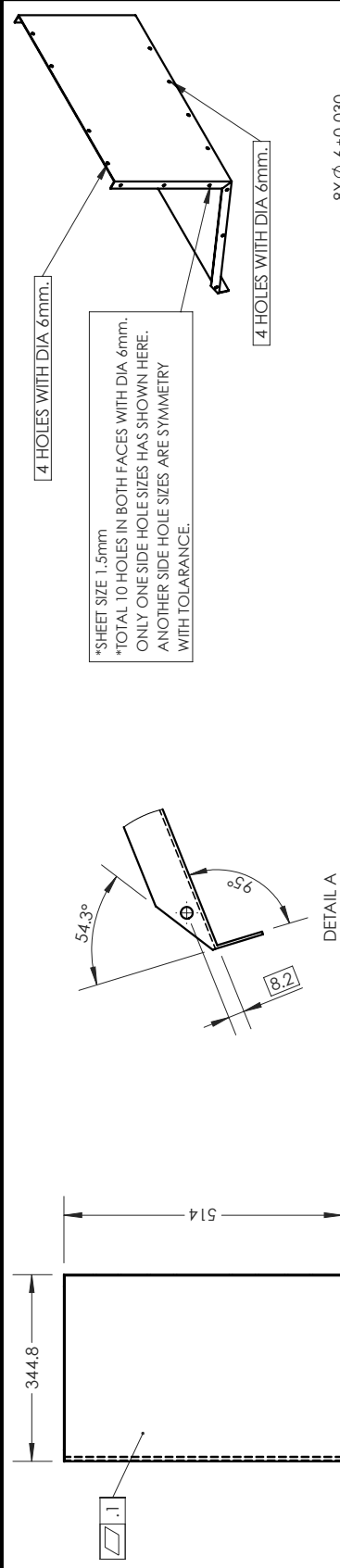

BANGLADESH RICE RESEARCH INSTITUTE
SFMRA PROJECT, FMPHT DIVISION

DO NOT SCALE DRAWING
FINISH: NONE
FIRST ISSUED: 02-AUG-2023

TITLE: BRRI COMPACT RICE MILL (BRRI RM2023)

DRG. NAME: RUBBER ROLLER INNER CASING PART - 1.1
DWG NO: RM2023_s2-014

MANUFACTURING METHOD: MACHINING, BENDING & WELDING
MATERIAL: Plain Carbon Steel
SCALE: 1:11 SHEET 55 REVISION: A

DETAILS	NAME	SIGNATURE	DATE
DRAWN	ENGR. SHAFER JAHAN RHAN	S J K	07-AUG-2023
CHK'D	DR. MD. MOSHARRAF HOSSAIN	M M H	18-DEC-2023
APP'D	DR. AKM SAIFUL ISLAM	A S I	30-DEC-2023

UNLESS OTHERWISE SPECIFIED:
STD. TOLERANCE DIMENSIONS ARE IN MILLIMETER
MILLIMETER: ±0.1, ANGULAR: ± 0.08°
* DOES NOT APPLY TO HOLE SIZE

THIRD ANGLE PROJECTION:

NOTE: DEBURR AND BREAK SHARP EDGES ALL BENDS MIN. RADIUS UNLESS SPECIFIED

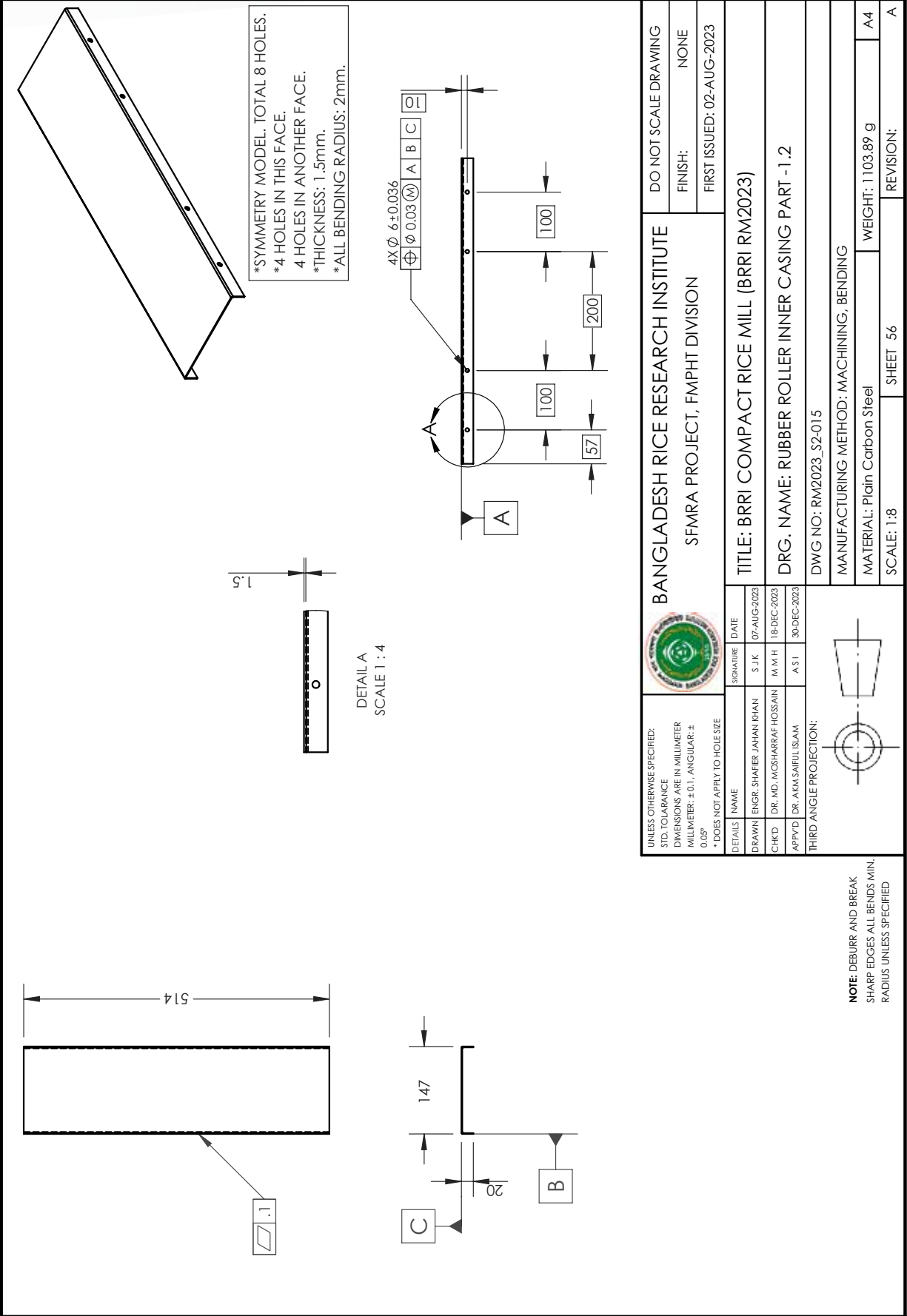

*SYMMETRY MODEL. TOTAL 8 HOLES.
 *4 HOLES IN THIS FACE.
 *4 HOLES IN ANOTHER FACE.
 *THICKNESS: 1.5mm.
 *ALL BENDING RADIUS: 2mm.

DETAIL A
 SCALE 1 : 4

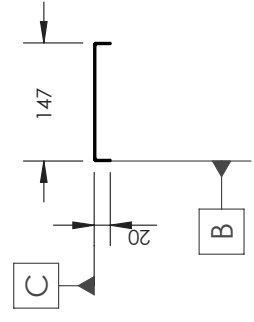
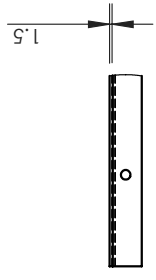

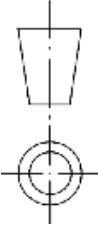

UNLESS OTHERWISE SPECIFIED: STD. TOLERANCE DIMENSIONS ARE IN MILLIMETER MILLIMETER: ±0.1, ANGULAR: ±0.08° * DOES NOT APPLY TO HOLE SIZE				BANGLADESH RICE RESEARCH INSTITUTE SFMRA PROJECT, FMPHT DIVISION		DO NOT SCALE DRAWING
DETAILS	NAME	SIGNATURE	DATE	TITLE: BRRI COMPACT RICE MILL (BRRI RM2023) DRG. NAME: RUBBER ROLLER INNER CASING PART - 1.2 DWG NO: RM2023_s2-015		FINISH: NONE
DRAWN	ENGR. SHAFER JAHAN RHAN	S J K	07-AUG-2023	DRG. NAME: RUBBER ROLLER INNER CASING PART - 1.2 DWG NO: RM2023_s2-015		FIRST ISSUED: 02-AUG-2023
CHK'D	DR. MD. MOSHARRAF HOSSAIN	M M H	18-DEC-2023	MANUFACTURING METHOD: MACHINING, BENDING MATERIAL: Plain Carbon Steel SCALE: 1:8		
APP'VD	DR. AKM SAIFUL ISLAM	A S I	30-DEC-2023	SHEET 56 REVISION: A		
THIRD ANGLE PROJECTION:						

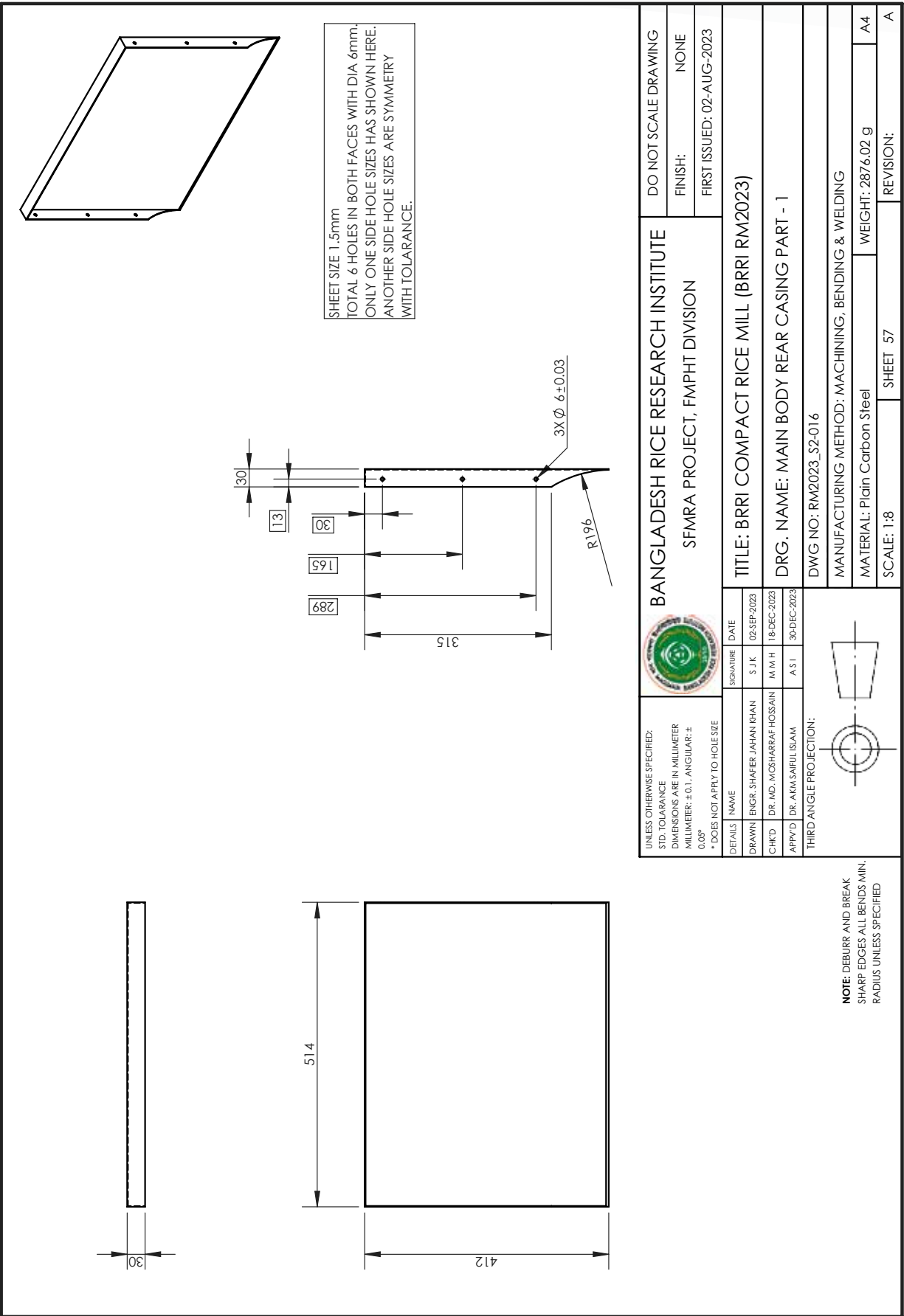
NOTE: DEBURR AND BREAK SHARP EDGES ALL BENDS MIN. RADIUS UNLESS SPECIFIED

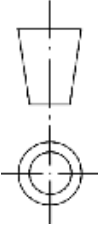

SHEET SIZE 1.5mm
 TOTAL 6 HOLES IN BOTH FACES WITH DIA 6mm.
 ONLY ONE SIDE HOLE SIZES HAS SHOWN HERE.
 ANOTHER SIDE HOLE SIZES ARE SYMMETRY
 WITH TOLERANCE.

UNLESS OTHERWISE SPECIFIED: STD. TOLERANCE DIMENSIONS ARE IN MILLIMETER MILLIMETER: ±0.1, ANGULAR: ±0.05° * DOES NOT APPLY TO HOLE SIZE				BANGLADESH RICE RESEARCH INSTITUTE SFMRA PROJECT, FMPHT DIVISION		DO NOT SCALE DRAWING	
DETAILS		NAME	SIGNATURE	DATE	FINISH: NONE		
DRAWN		ENGR. SHAFER JAHAN KHAN	S J K	02-SEP-2023	FIRST ISSUED: 02-AUG-2023		
CHK'D		DR. MD. MOSHARRAF HOSSAIN	M M H	18-DEC-2023	TITLE: BRRI COMPACT RICE MILL (BRRI RM2023)		
APP'D		DR. AKM SAIFUL ISLAM	A S I	30-DEC-2023	DRG. NAME: MAIN BODY REAR CASING PART - 1		
THIRD ANGLE PROJECTION:				DWG NO: RM2023_S2-016			
NOTE: DEBURR AND BREAK SHARP EDGES ALL BENDS MIN. RADIUS UNLESS SPECIFIED				MANUFACTURING METHOD: MACHINING, BENDING & WELDING			
		MATERIAL: Plain Carbon Steel		WEIGHT: 2876.02 g		REVISION: A	
		SCALE: 1:8		SHEET 57		A	

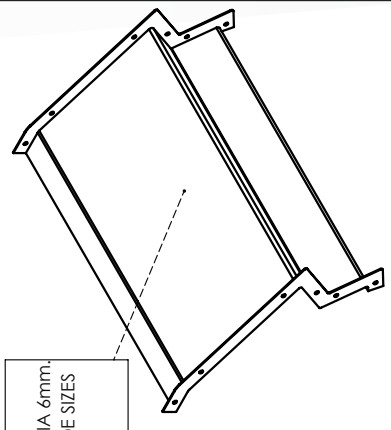

*SHEET THICKNESS: 1.5mm
 *TOTAL 12 HOLES IN BOTH FACES WITH DIA 6mm.
 MODEL IS SYMMETRY SO ONLY ONE SIDE SIZES
 HAS SHOWN HERE.
 *ALL BENDING RADIUS: 2mm

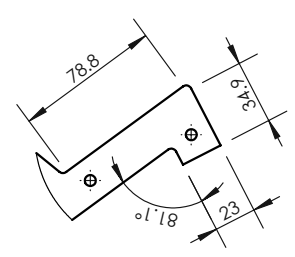

DETAIL B
 SCALE 2 : 7

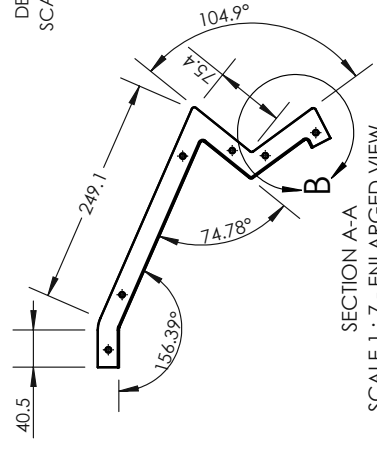

SECTION A-A
 SCALE 1 : 7 - ENLARGED VIEW

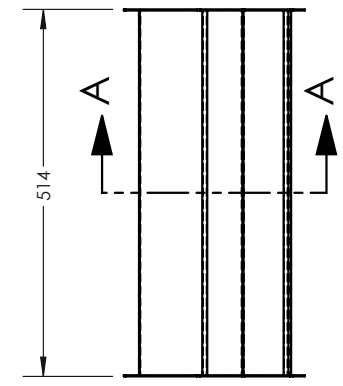
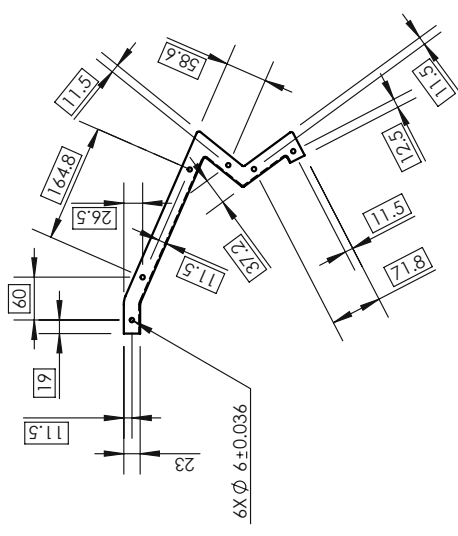
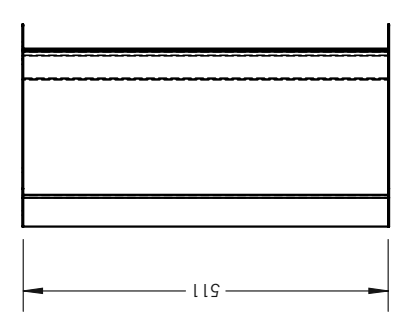

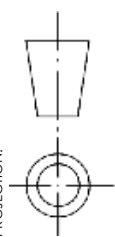
		BANGLADESH RICE RESEARCH INSTITUTE SFMRA PROJECT, FMPHT DIVISION		DO NOT SCALE DRAWING
UNLESS OTHERWISE SPECIFIED: STD. TOLERANCE DIMENSIONS ARE IN MILLIMETER MILLIMETER: ±0.1, ANGULAR: ± 0.05° * DOES NOT APPLY TO HOLESIZE		SIGNATURE S J K	DATE 07-AUG-2023	FINISH: NONE
DRAWN ENGR. SHAFER JAHAN KHAN	CHECKED DR. MD. MOSHARRAF HOSSAIN	APPROVED DR. AKM SAIBUL ISLAM	DATE 18-DEC-2023 30-DEC-2023	FIRST ISSUED: 02-AUG-2023
TITLE: BRRI COMPACT RICE MILL (BRRI RM2023)				
DRG. NAME: RUBBER ROLLER OUTER CASING PART - 1.2				
DWG NO: RM2023_s2-017				
MANUFACTURING METHOD: MACHINING, BENDING & WELDING				
MATERIAL: Plain Carbon Steel			WEIGHT: 27.59.98 g	
SCALE: 1:9			SHEET 58	
THIRD ANGLE PROJECTION: 			REVISION: A	

NOTE: DEBURR AND BREAK SHARP EDGES ALL BENDS MIN. RADIUS UNLESS SPECIFIED

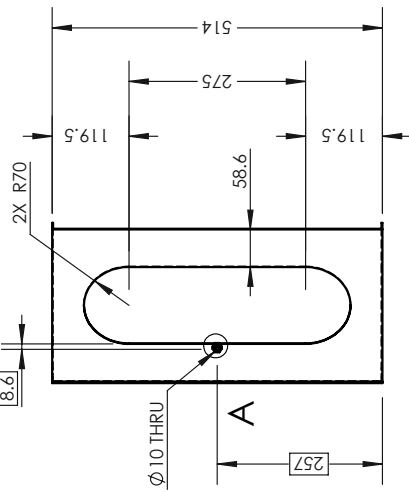

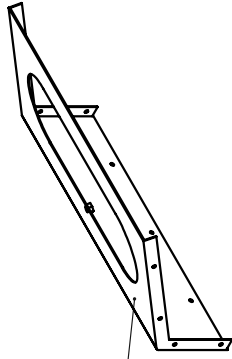

*SHEET SIZE 1.5mm
 *TOTAL 8 HOLES IN BOTH FACES.
 ONLY ONE SIDE HOLE SIZES HAS SHOWN HERE.
 ANOTHER SIDE HOLE SIZES ARE SYMMETRY
 WITH TOLARANCE.
 *ALL BENDING RADIUS: 2mm

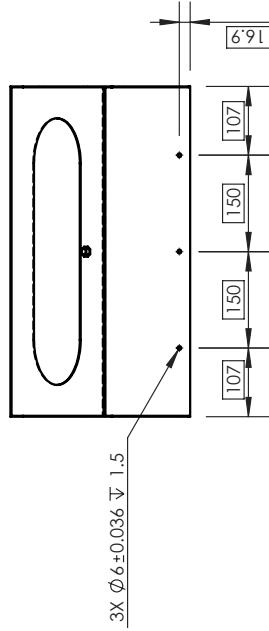
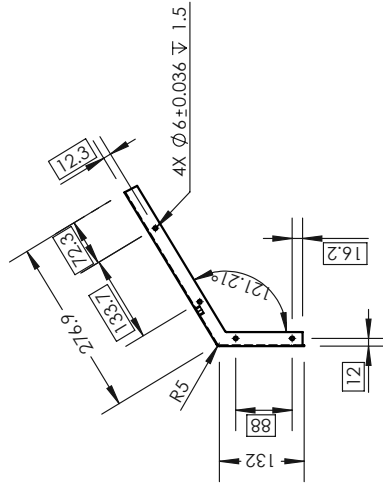

DETAIL A
 SCALE 1 : 4

N.B: A HEX NUT IS WELDED WITH THE FACE FOR LOCKING.
 MAINTAINING SAME SIZE AND THREAD A BOLT
 COMPONENT WILL MATE HERE.

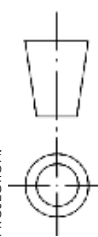

UNLESS OTHERWISE SPECIFIED: STD. TOLARANCE DIMENSIONS ARE IN MILLIMETER MILLIMETER: ±0.1, ANGULAR: ± 0.05° * DOES NOT APPLY TO HOLE SIZE				BANGLADESH RICE RESEARCH INSTITUTE SFMRA PROJECT, FMPHT DIVISION		DO NOT SCALE DRAWING	
DETAILS	NAME	SIGNATURE	DATE	FINISH: NONE		FIRST ISSUED: 02-AUG-2023	
DRAWN	ENGR. SHAFER JAHAN RHAN	S J K	07-AUG-2023	TITLE: BRRI COMPACT RICE MILL (BRRI RM2023)			
CHK'D	DR. MD. MOSHARRAF HOSSAIN	M M H	18-OCT-2023	DRG. NAME: POLISHER OUTER CASING PART - 1.1			
APP'VD	DR. AKM SAIBUL ISLAM	A S I	30-OCT-2023	DWG NO: RM2023_S2-018			
THIRD ANGLE PROJECTION:							
NOTE: DEBURR AND BREAK SHARP EDGES ALL BENDS MIN. RADIUS UNLESS SPECIFIED				MANUFACTURING METHOD: MACHINING, BENDING & WELDING			
				MATERIAL: Plain Carbon Steel		WEIGHT: 2045.87 g	
				SCALE: 1:8		REVISION: A	
				SHEET 59		A	

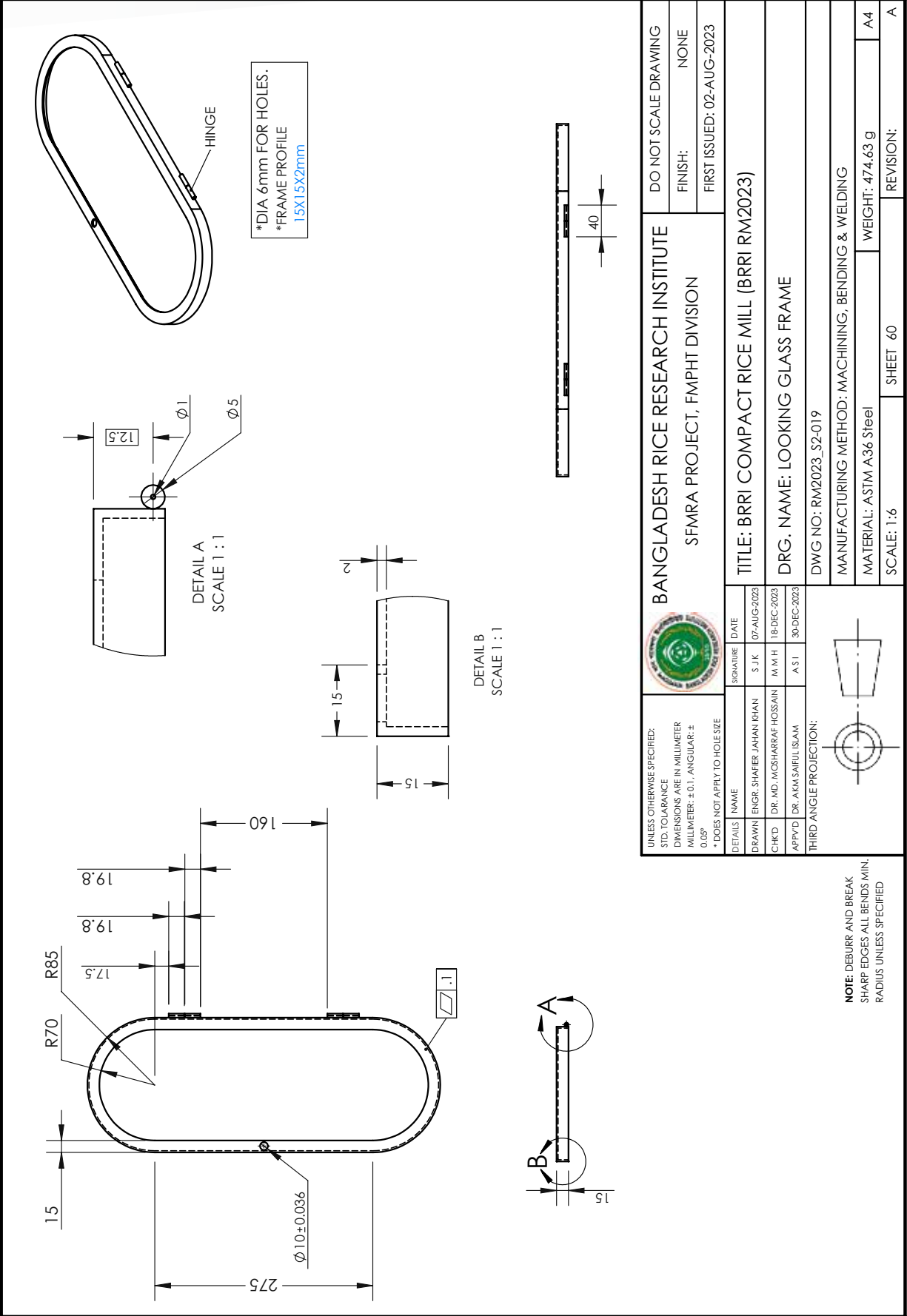

*DIA 6mm FOR HOLES.
 *FRAME PROFILE
 1.5X1.5X2mm

DETAIL A
 SCALE 1 : 1

DETAIL B
 SCALE 1 : 1

NOTE: DEBURR AND BREAK
 SHARP EDGES ALL BENDS MIN.
 RADIUS UNLESS SPECIFIED

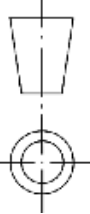
UNLESS OTHERWISE SPECIFIED: STD. TOLERANCE DIMENSIONS ARE IN MILLIMETER MILLIMETER: ±0.1, ANGULAR: ± 0.05° * DOES NOT APPLY TO HOLE SIZE				BANGLADESH RICE RESEARCH INSTITUTE SFMRA PROJECT, FMPHT DIVISION		DO NOT SCALE DRAWING FINISH: NONE FIRST ISSUED: 02-AUG-2023	
DETAILS	NAME	SIGNATURE	DATE	TITLE: BRRI COMPACT RICE MILL (BRRI RM2023)			
DRAWN	ENGR. SHAFER JAHAN RHAN	S J K	07-AUG-2023	DRG. NAME: LOOKING GLASS FRAME			
CHK'D	DR. MD. MOSHARRAF HOSSAIN	M M H	18-DEC-2023	DWG NO: RM2023_S2-019			
APP'VD	DR. AKM SAIBUL ISLAM	A S I	30-DEC-2023	MANUFACTURING METHOD: MACHINING, BENDING & WELDING			
THIRD ANGLE PROJECTION:							
				MATERIAL: ASTM A36 Steel SCALE: 1:6 SHEET 60		WEIGHT: 474.63 g REVISION: A	

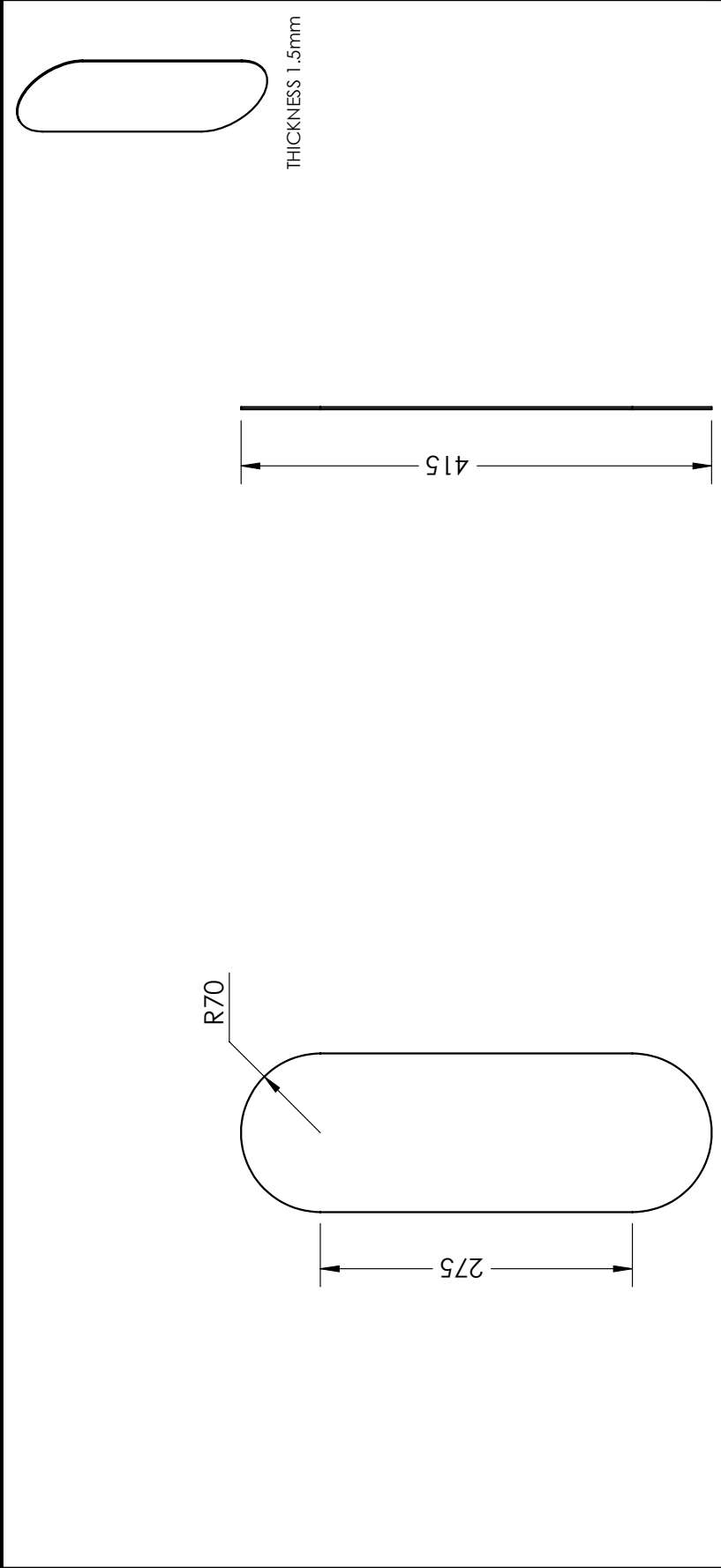

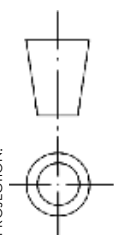
UNLESS OTHERWISE SPECIFIED: STD. TOLERANCE DIMENSIONS ARE IN MILLIMETER MILLIMETER: ±0.1, ANGULAR: ±0.05° * DOES NOT APPLY TO HOLE SIZE				BANGLADESH RICE RESEARCH INSTITUTE SFMRA PROJECT, FMPHT DIVISION		DO NOT SCALE DRAWING	
DETAILS		NAME	SIGNATURE	DATE	TITLE: BRI COMPACT RICE MILL (BRI RM2023)		
DRAWN		ENGR. SHAFER JAHAN KHAN	S. J.K	07-AUG-2023	DRG. NAME: LOOKING GLASS		
CHK'D		DR. MD. MOSHARRAF HOSSAIN	M. M.H	18-DEC-2023	DWG NO: RM2023_S2-020		
APP'D		DR. AKM SAIFUL ISLAM	A.S.I	30-DEC-2023	MANUFACTURING METHOD: MACHINING		
THIRD ANGLE PROJECTION:							
				MATERIAL: Glass			
SCALE: 1:5				SHEET: 61		REVISION: A	
WEIGHT: 264.90 g				A4			

NOTE: DEBURR AND BREAK SHARP EDGES ALL BENDS MIN. RADIUS UNLESS SPECIFIED

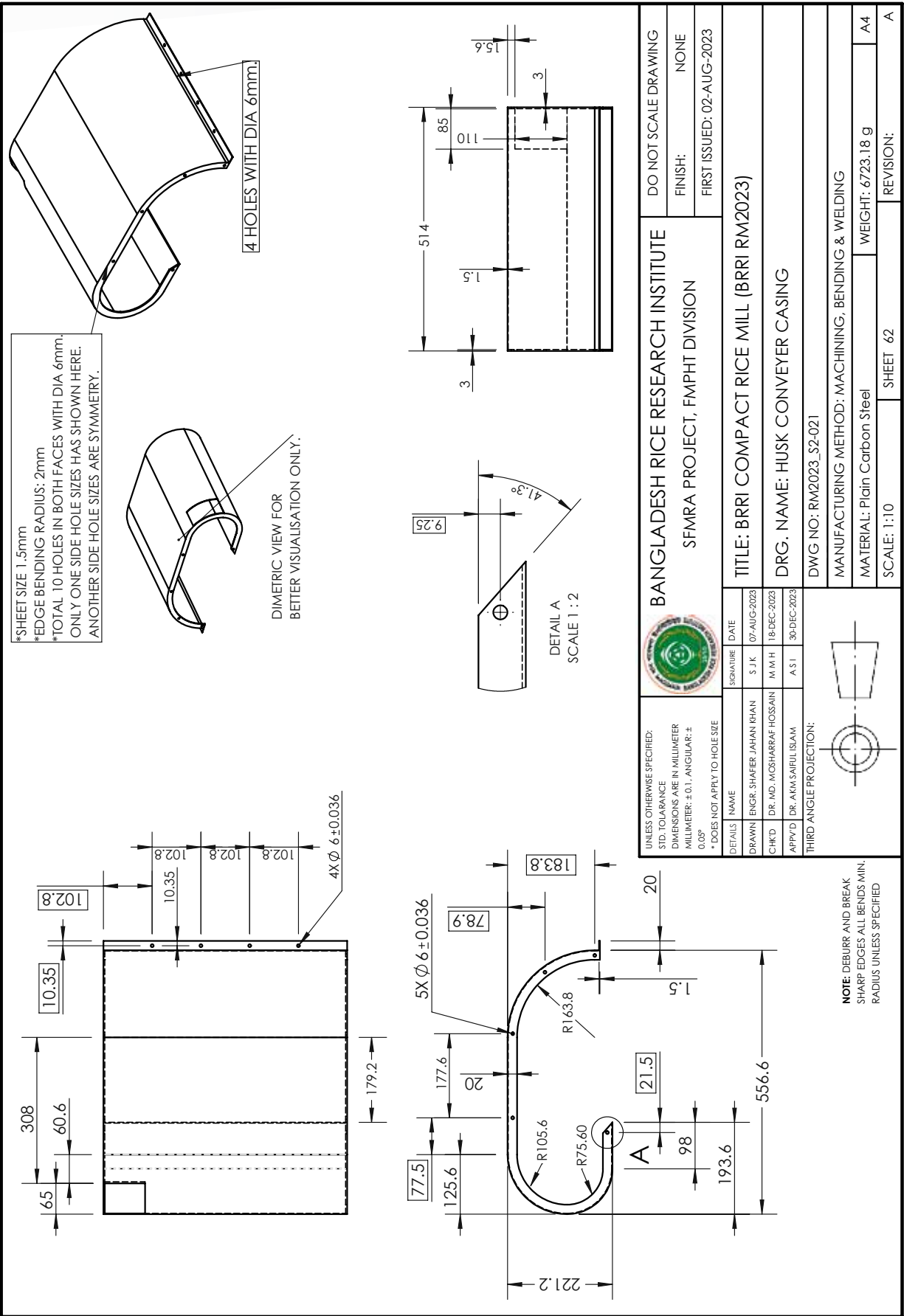

*SHEET SIZE 1.5mm
 *EDGE BENDING RADIUS: 2mm
 *TOTAL 10 HOLES IN BOTH FACES WITH DIA 6mm,
 ONLY ONE SIDE HOLE SIZES HAS SHOWN HERE.
 ANOTHER SIDE HOLE SIZES ARE SYMMETRY.

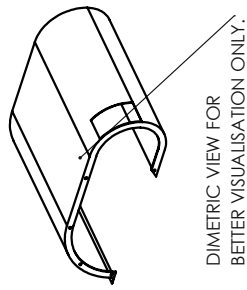

4 HOLES WITH DIA 6mm.

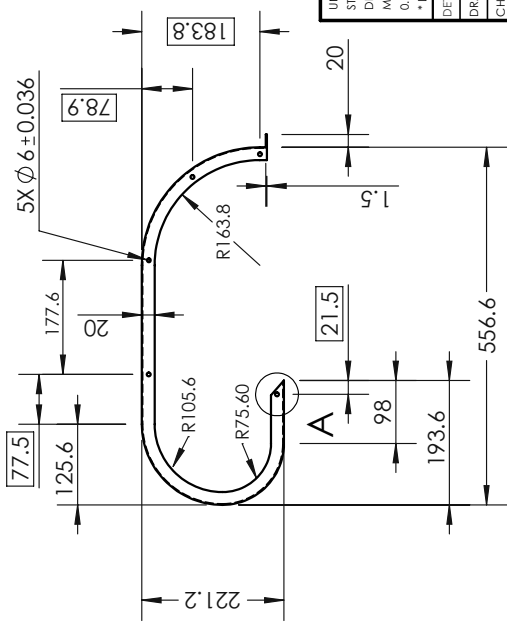
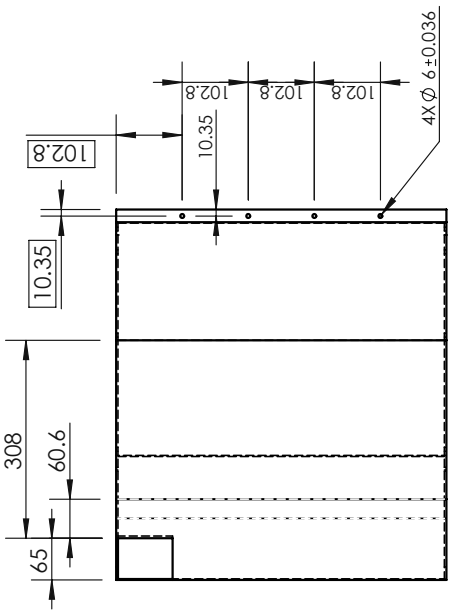
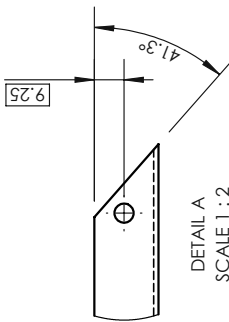
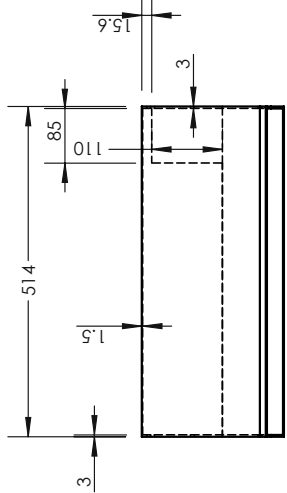

NOTE: DEBURR AND BREAK SHARP EDGES ALL BENDS MIN. RADIUS UNLESS SPECIFIED

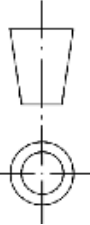
UNLESS OTHERWISE SPECIFIED: STD. TOLERANCE DIMENSIONS ARE IN MILLIMETER MILLIMETER: ±0.1, ANGULAR: ±0.05° * DOES NOT APPLY TO HOLE SIZE		 BANGLADESH RICE RESEARCH INSTITUTE SFMRA PROJECT, FMPHT DIVISION		DO NOT SCALE DRAWING
DETAILS	NAME	SIGNATURE	DATE	FINISH: NONE
DRAWN	ENGR. SHAFER JAHAN KHAN	S J K	07-AUG-2023	FIRST ISSUED: 02-AUG-2023
CHK'D	DR. MD. MOSHARRAF HOSSAIN	M M H	18-DEC-2023	
APP'VD	DR. AKM SAIBUL ISLAM	A S I	30-DEC-2023	
THIRD ANGLE PROJECTION:				
				
TITLE: BRRI COMPACT RICE MILL (BRRI RM2023) DRG. NAME: HUSK CONVEYER CASING DWG NO: RM2023_S2-021 MANUFACTURING METHOD: MACHINING, BENDING & WELDING MATERIAL: Plain Carbon Steel WEIGHT: 6723.18 g SCALE: 1:10 SHEET 62 REVISION: A				

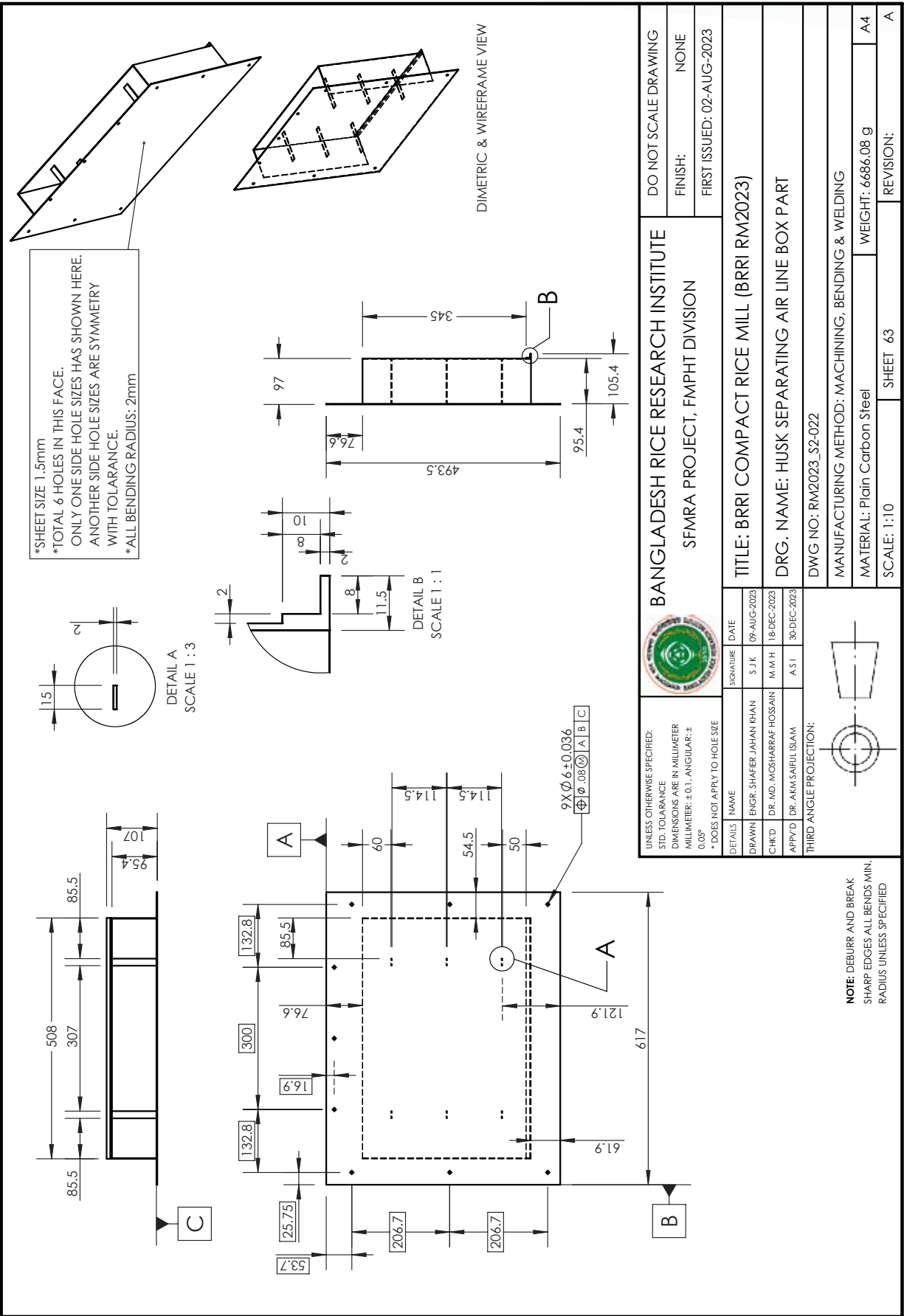

*SHEET SIZE 1.5mm
 *TOTAL 6 HOLES IN THIS FACE.
 ONLY ONE SIDE HOLE SIZES HAS SHOWN HERE.
 ANOTHER SIDE HOLE SIZES ARE SYMMETRY
 WITH TOLARANCE.
 *ALL BENDING RADIUS: 2mm

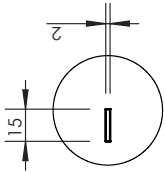

DETAIL A
 SCALE 1 : 3

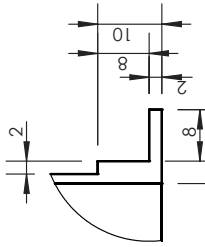

DETAIL B
 SCALE 1 : 1

DIMETRIC & WIREFRAME VIEW

 BANGLADESH RICE RESEARCH INSTITUTE SFMRA PROJECT, FMPHT DIVISION		DO NOT SCALE DRAWING	
		FINISH: NONE	FIRST ISSUED: 02-AUG-2023
TITLE: BRRI COMPACT RICE MILL (BRRI RM2023)			
DRG. NAME: HUSK SEPARATING AIR LINE BOX PART			
DWG NO: RM2023_S2-022			
MANUFACTURING METHOD: MACHINING, BENDING & WELDING			
MATERIAL: Plain Carbon Steel		WEIGHT: 6886.08 g	
SCALE: 1:10		SHEET 63	
REVISION:		A	

UNLESS OTHERWISE SPECIFIED:
 STD. TOLARANCE DIMENSIONS ARE IN MILLIMETER
 MILLIMETER: ±0.1, ANGULAR: ±0.05°
 * DOES NOT APPLY TO HOLE SIZE

DETAILS	NAME	SIGNATURE	DATE
DRAWN	ENGR. SHAFER JAHAN RHAN	S J K	09-AUG-2023
CHK'D	DR. MD. MOSHARRAF HOSSAIN	M M H	18-DEC-2023
APP'VD	DR. AKM SAIBUL ISLAM	A S I	30-DEC-2023

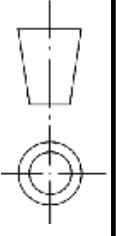

THIRD ANGLE PROJECTION:

NOTE: DEBURR AND BREAK SHARP EDGES ALL BENDS MIN. RADIUS UNLESS SPECIFIED

*SHEET SIZE 1.5mm
 *TOTAL 2+2=4 HOLES IN BOTH FACE.
 ONLY ONE SIDE HOLE SIZES HAS SHOWN HERE.
 ANOTHER SIDE HOLE SIZES ARE SYMMETRY
 WITH TOLERANCE.
 *ALL BENDING RADIUS: 2mm

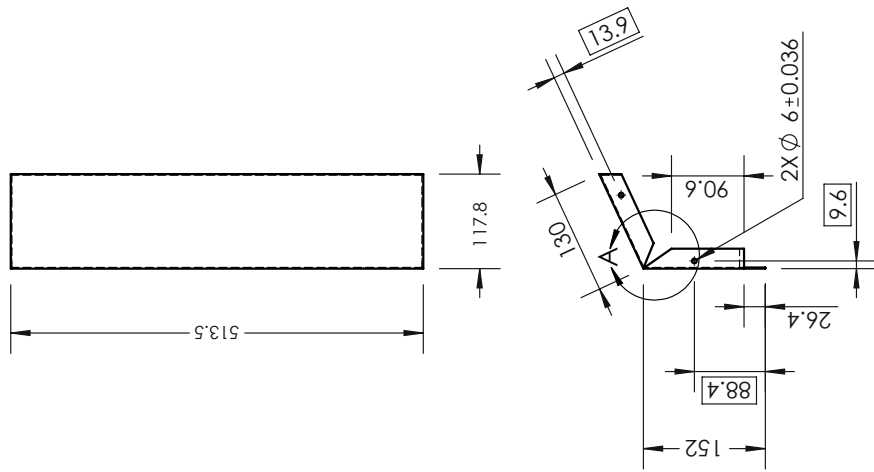
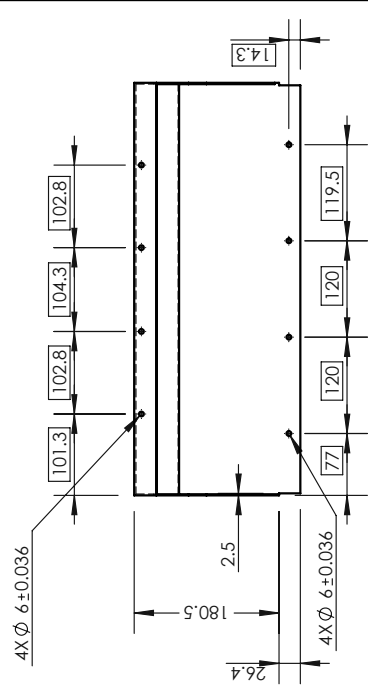
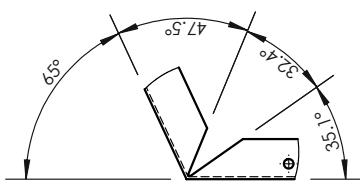

DETAIL A
 SCALE 1 : 4

UNLESS OTHERWISE SPECIFIED: STD. TOLERANCE DIMENSIONS ARE IN MILLIMETER MILLIMETER: ±0.1, ANGULAR: ±0.05° * DOES NOT APPLY TO HOLE SIZE		SIGNATURE DATE	
DETAILS	NAME	SIGNATURE	DATE
DRAWN	ENGR. SHAFER JAHAN KHAN	S J K	09-AUG-2023
CHK'D	DR. MD. MOSHARRAF HOSSAIN	M M H	18-DEC-2023
APP'D	DR. AKM SAIBUL ISLAM	A S I	30-DEC-2023



BANGLADESH RICE RESEARCH INSTITUTE
 SFMRA PROJECT, FMPHT DIVISION

DO NOT SCALE DRAWING
 FINISH: NONE
 FIRST ISSUED: 02-AUG-2023

TITLE: BRRI COMPACT RICE MILL (BRRI RM2023)	
DRG. NAME: POLISHER CASING PART - 1.1	
DWG NO: RM2023_S2-023	
MANUFACTURING METHOD: MACHINING, BENDING & WELDING	
MATERIAL: Plain Carbon Steel	WEIGHT: 1954.26 g
SCALE: 1:8	SHEET 64
REVISION:	A

NOTE: DEBURR AND BREAK SHARP EDGES ALL BENDS MIN. RADIUS UNLESS SPECIFIED

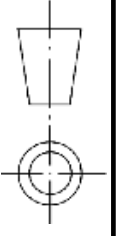

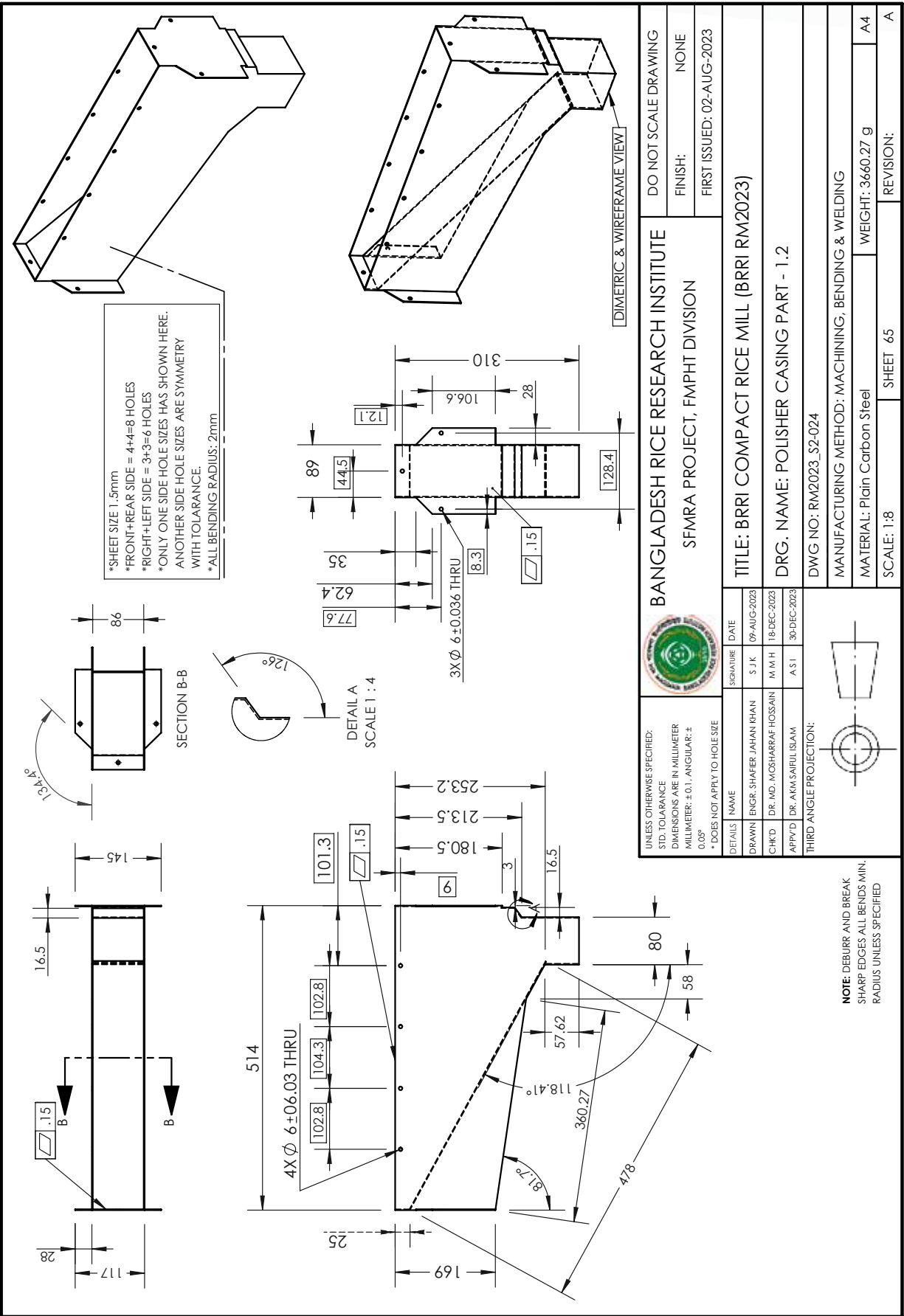

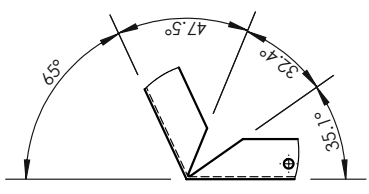
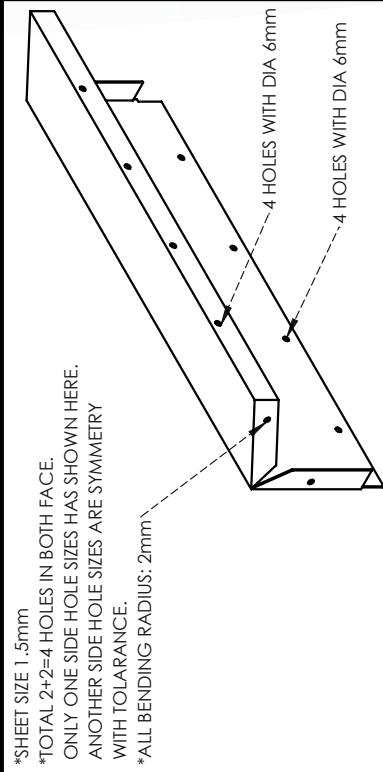

DETAIL A
SCALE 1 : 4

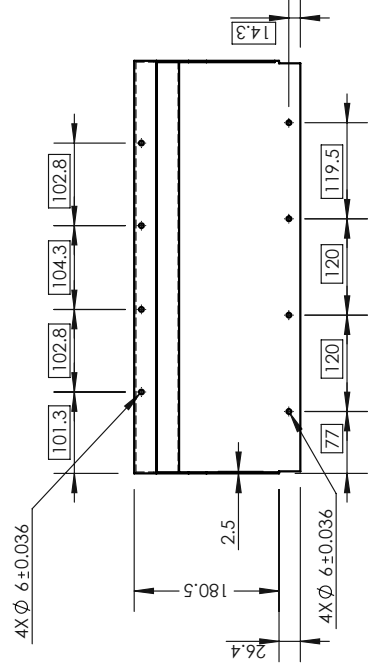
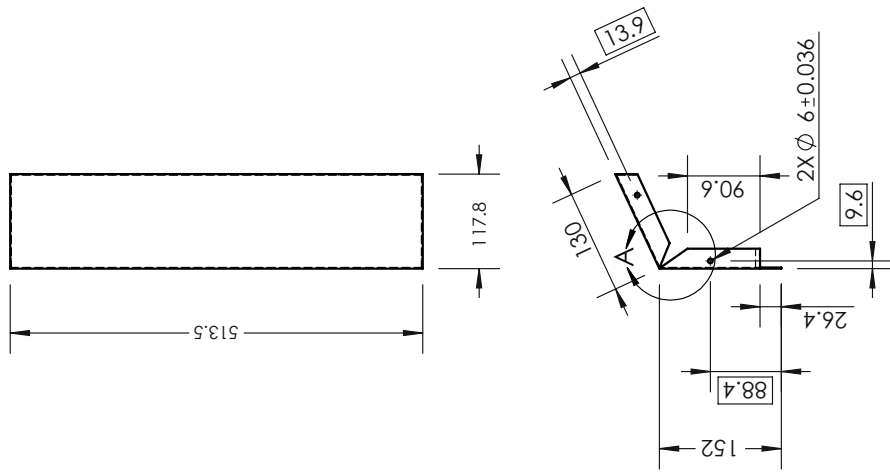

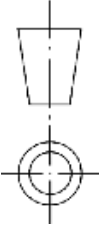
UNLESS OTHERWISE SPECIFIED: STD. TOLERANCE DIMENSIONS ARE IN MILLIMETER MILLIMETER: ±0.1, ANGULAR: ±0.05° * DOES NOT APPLY TO HOLE SIZE				BANGLADESH RICE RESEARCH INSTITUTE SFMRA PROJECT, FMPHT DIVISION		DO NOT SCALE DRAWING FINISH: NONE FIRST ISSUED: 02-AUG-2023	
DETAILS	NAME	SIGNATURE	DATE				
DRAWN	ENGR. SHAFER JAHAN RHAN	S J K	09-AUG-2023				
CHK'D	DR. MD. MOSHARRAF HOSSAIN	M M H	18-DEC-2023				
APP'D	DR. AKM SAIBUL ISLAM	A S I	30-DEC-2023				
THIRD ANGLE PROJECTION:							
TITLE: BRRI COMPACT RICE MILL (BRRI RM2023) DRG. NAME: POLISHER CASING PART - 1.1 DWG NO: RM2023_S2-023							
MANUFACTURING METHOD: MACHINING, BENDING & WELDING							
MATERIAL: Plain Carbon Steel				WEIGHT: 1954.26 g			
SCALE: 1:8				SHEET 64		REVISION:	
				A4		A	

NOTE: DEBURR AND BREAK SHARP EDGES ALL BENDS MIN. RADIUS UNLESS SPECIFIED

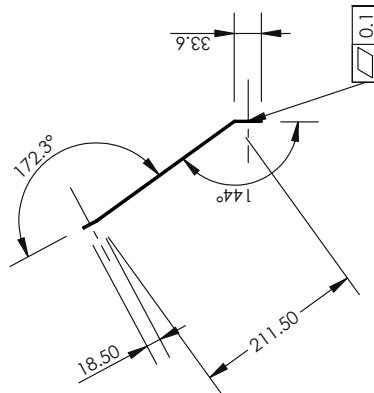
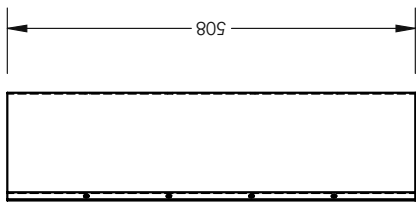

*THICKNESS 1.5mm
 *DIA 6mm FOR THE HOLES.
 *BENDING RADIUS: 2mm

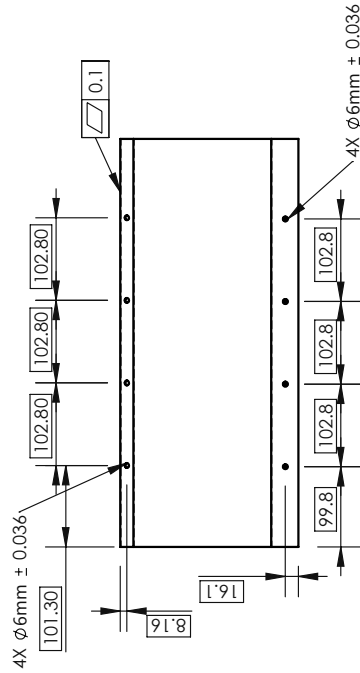
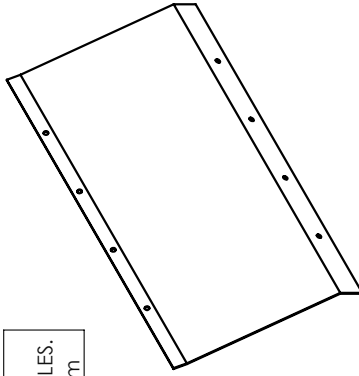

BANGLADESH RICE RESEARCH INSTITUTE
 SFMRA PROJECT, FMPHT DIVISION

DO NOT SCALE DRAWING
 FINISH: NONE
 FIRST ISSUED: 02-AUG-2023

TITLE: BRRI COMPACT RICE MILL (BRRI RM2023)

DRG. NAME: INTERNAL BODY PART - 2 - HUSK LINE SUPPORT

DWG NO: RM2023_S2-026

MANUFACTURING METHOD: MACHINING & BENDING

MATERIAL: Plain Carbon Steel

WEIGHT: 1563.40 g

SCALE: 1:8 SHEET 67

REVISION: A

UNLESS OTHERWISE SPECIFIED:
 STD. TOLERANCE DIMENSIONS ARE IN MILLIMETER
 MILLIMETER: ±0.1, ANGULAR: ±0.05°
 * DOES NOT APPLY TO HOLE SIZE

DETAILS	NAME	SIGNATURE	DATE
DRAWN	ENGR. SHAFER JAHAN KHAN	S J K	09-AUG-2023
CHK'D	DR. MD. MOSHARRAF HOSSAIN	M M H	18-DEC-2023
APP'VD	DR. AKM SAIFUL ISLAM	A S I	30-DEC-2023

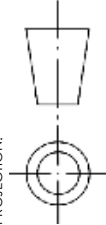

THIRD ANGLE PROJECTION:

NOTE: DEBURR AND BREAK SHARP EDGES ALL BENDS MIN. RADIUS UNLESS SPECIFIED

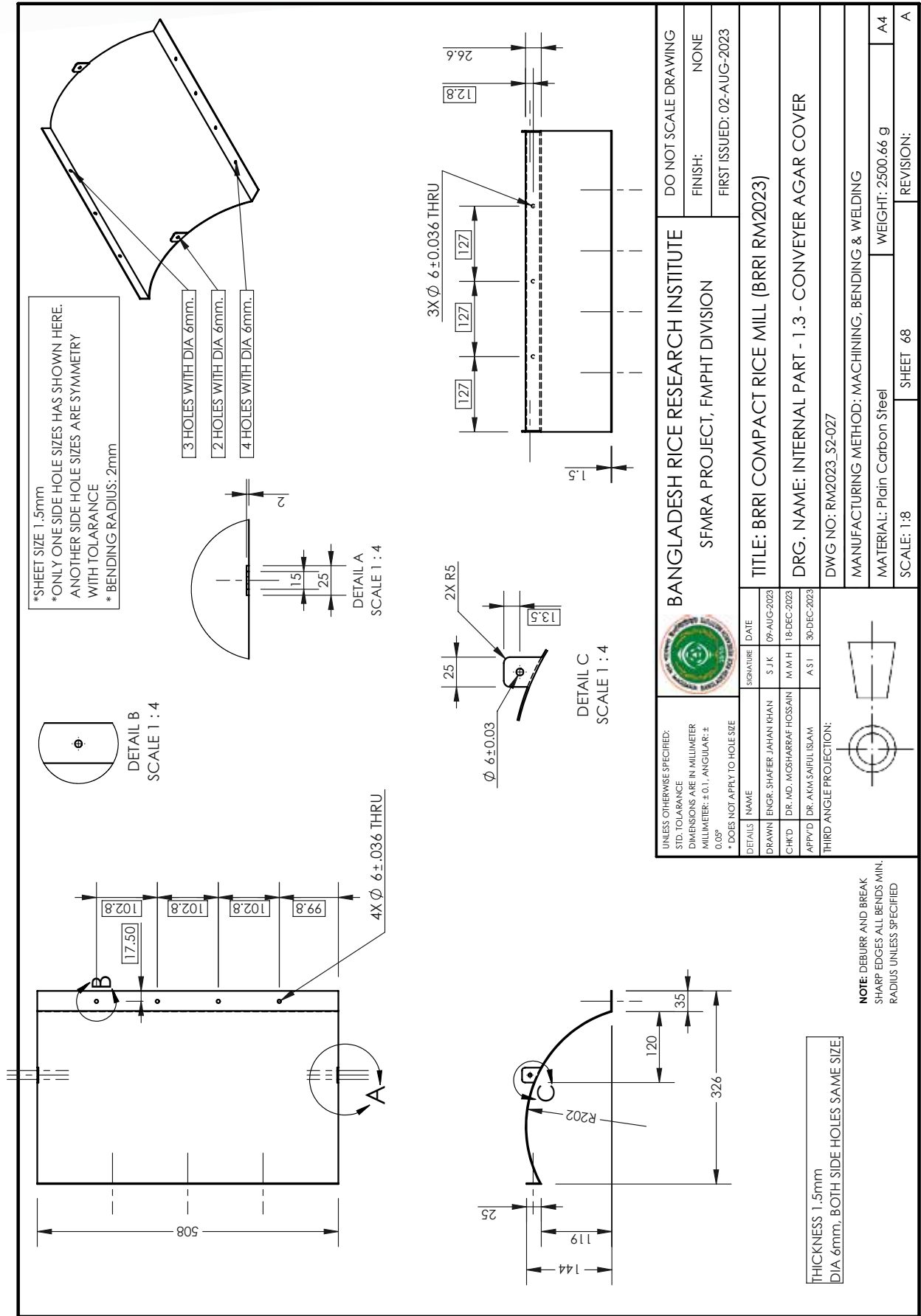

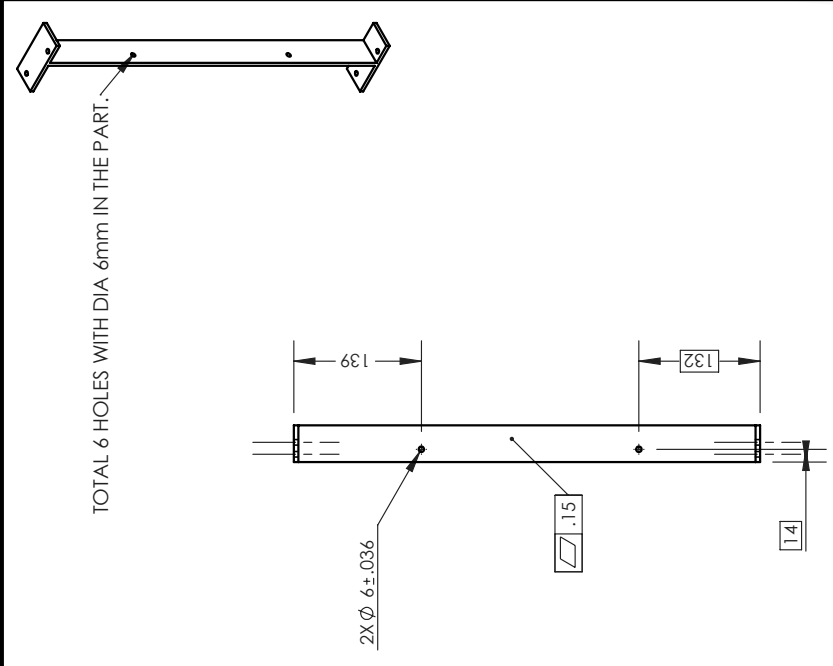

		BANGLADESH RICE RESEARCH INSTITUTE SFMRA PROJECT, FMPHT DIVISION		DO NOT SCALE DRAWING
				FINISH: NONE
				FIRST ISSUED: 02-AUG-2023
		TITLE: BRRI COMPACT RICE MILL (BRRI RM2023)		
		DRG. NAME: INTERNAL PART - 1.3 - CONVEYER AGAR COVER		
		DWG NO: RM2023_S2-027		
		MANUFACTURING METHOD: MACHINING, BENDING & WELDING		
		MATERIAL: Plain Carbon Steel		
		WEIGHT: 2500.66 g		
		SCALE: 1:8		
		SHEET 68		
		REVISION: A		

UNLESS OTHERWISE SPECIFIED: STD. TOLARANCE DIMENSIONS ARE IN MILLIMETER MILLIMETER: ±0.1, ANGULAR: ±0.05° * DOES NOT APPLY TO HOLE SIZE		SIGNATURE S. J.K	DATE 09-AUG-2023
DRAWN ENGR. SHAFER JAHAN KHAN	M. M. H	18-DEC-2023	30-DEC-2023
CHK'D DR. MD. MOSHARRAF HOSSAIN	A. S. I	THIRD ANGLE PROJECTION:	

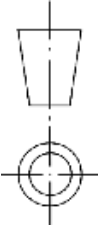

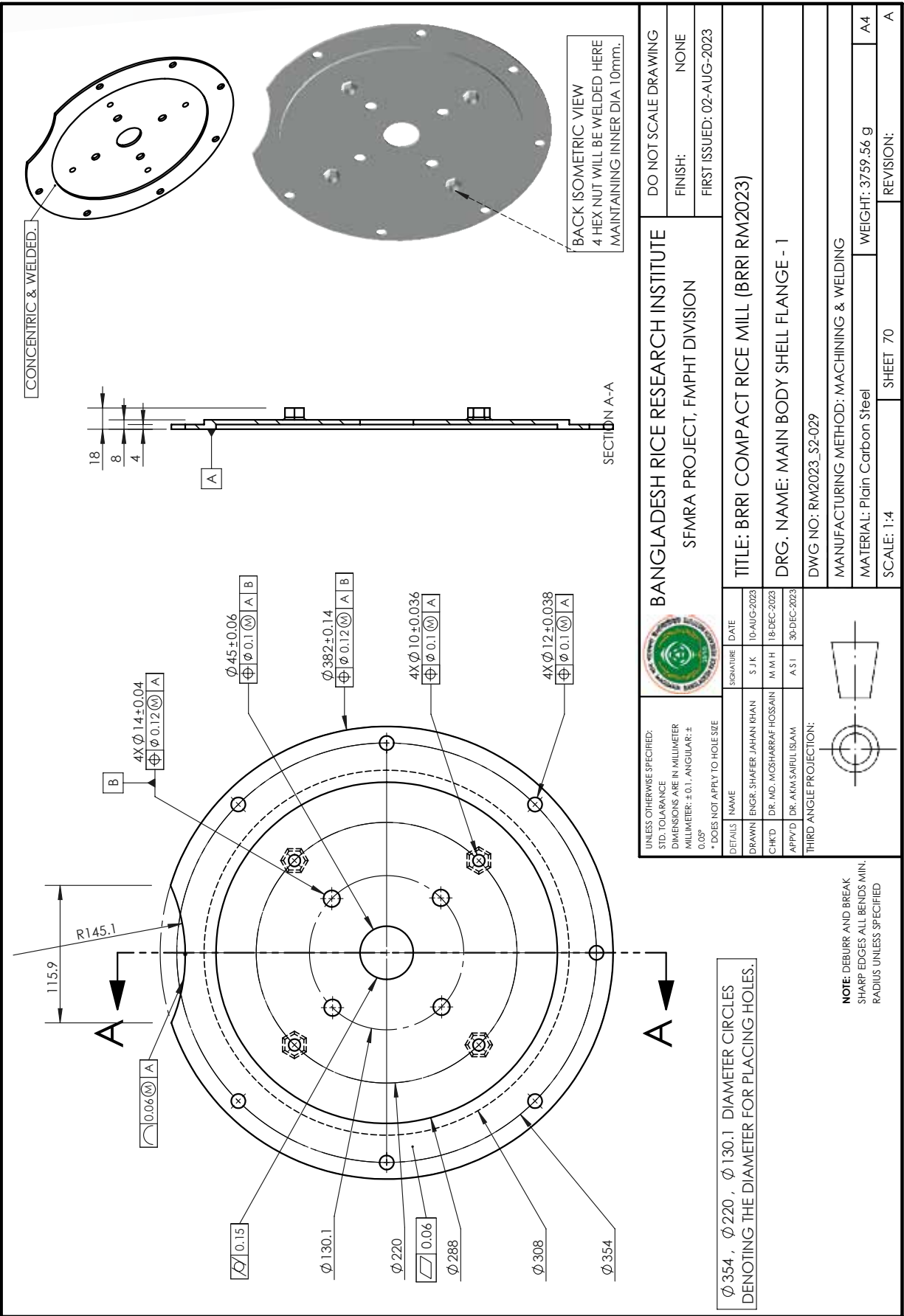

UNLESS OTHERWISE SPECIFIED: STD. TOLERANCE DIMENSIONS ARE IN MILLIMETER MILLIMETER: ±0.1, ANGULAR: ±0.08° * DOES NOT APPLY TO HOLE SIZE				BANGLADESH RICE RESEARCH INSTITUTE SFMRA PROJECT, FMPHT DIVISION		DO NOT SCALE DRAWING	
DETAILS		NAME	SIGNATURE	DATE	FINISH: NONE		
DRAWN		ENGR. SHAFER JAHAN RHAN	S J K	09-AUG-2023	FIRST ISSUED: 02-AUG-2023		
CHK'D		DR. MD. MOSHARRAF HOSSAIN	M M H	18-DEC-2023	TITLE: BRRI COMPACT RICE MILL (BRRI RM2023)		
APP'VD		DR. AKM SAIFUL ISLAM	A S I	30-DEC-2023	DRG. NAME: INNER BLOWER SUPPORT PART		
THIRD ANGLE PROJECTION:				DWG NO: RM2023_S2-028			
NOTE: DEBURR AND BREAK SHARP EDGES ALL BENDS MIN. RADIUS UNLESS SPECIFIED				MANUFACTURING METHOD: MACHINING, BENDING & WELDING			
				MATERIAL: ASTM A36 Steel		WEIGHT: 1027.97 g	
				SCALE: 1:7		REVISION: A	
				SHEET 69		A	

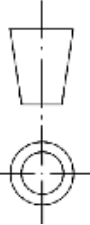

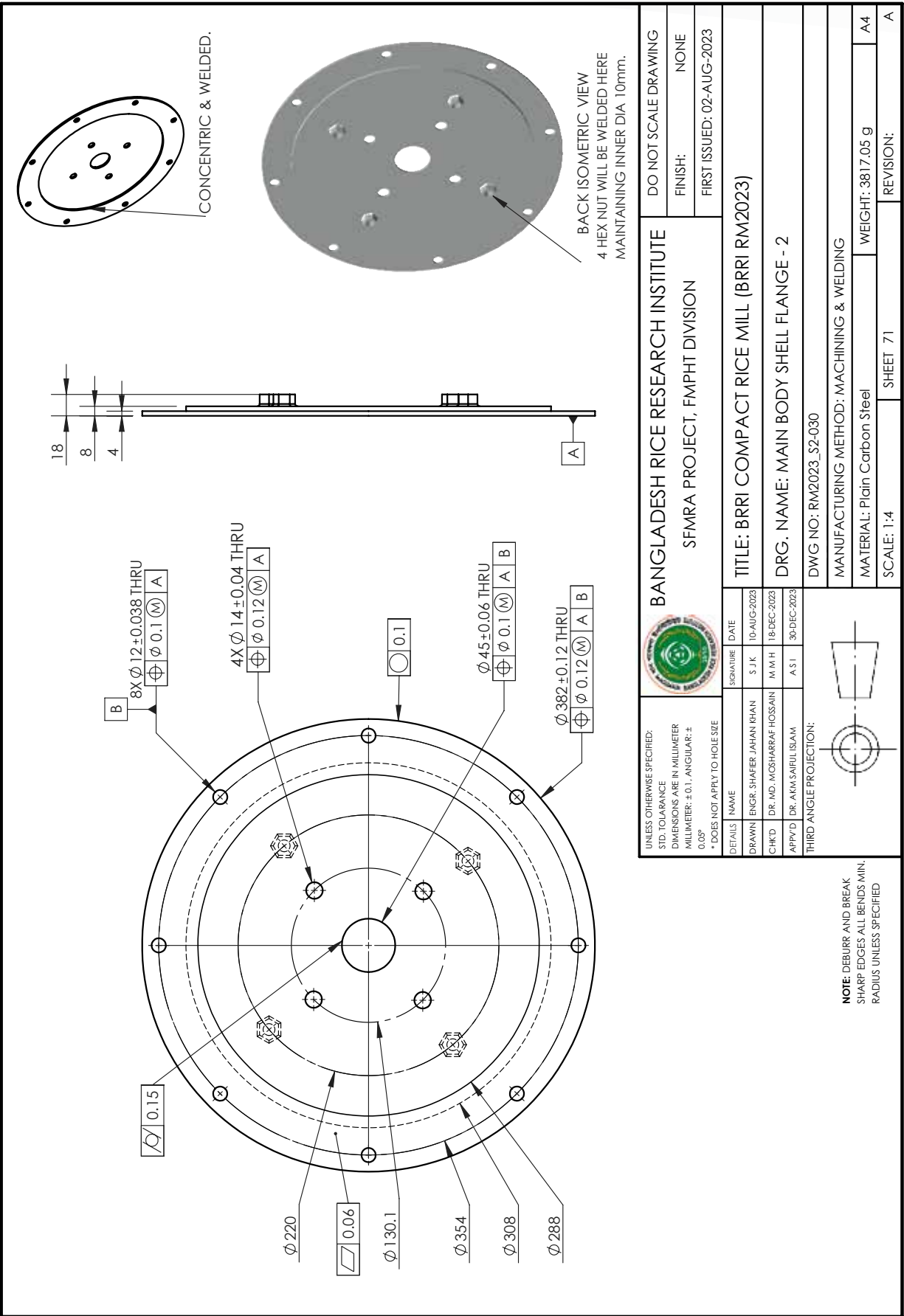

UNLESS OTHERWISE SPECIFIED: STD. TOLERANCE DIMENSIONS ARE IN MILLIMETER MILLIMETER: ±0.1, ANGULAR: ±0.05° * DOES NOT APPLY TO HOLE SIZE				BANGLADESH RICE RESEARCH INSTITUTE SFMRA PROJECT, FMPHT DIVISION		DO NOT SCALE DRAWING FINISH: NONE FIRST ISSUED: 02-AUG-2023	
DETAILS	NAME	SIGNATURE	DATE	TITLE: BRRI COMPACT RICE MILL (BRRI RM2023)			
	ENGR. SHAFER JAHAN KHAN	S J K	10-AUG-2023	DRG. NAME: MAIN BODY SHELL FLANGE - 1			
CHK'D	DR. MD. MOSHARRAF HOSSAIN	M M H	18-DEC-2023	DWG NO: RM2023_S2-029			
APP'VD	DR. AKM SAIBUL ISLAM	A S I	30-DEC-2023	MANUFACTURING METHOD: MACHINING & WELDING			
THIRD ANGLE PROJECTION:							
NOTE: DEBURR AND BREAK SHARP EDGES ALL BENDS MIN. RADIUS UNLESS SPECIFIED				MATERIAL: Plain Carbon Steel			
				SCALE: 1:4		SHEET 70	
				WEIGHT: 3759.56 g		REVISION:	
				A4		A	

Ø 354 , Ø 220 , Ø 130.1 DIAMETER CIRCLES DENOTING THE DIAMETER FOR PLACING HOLES.

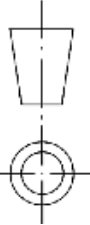

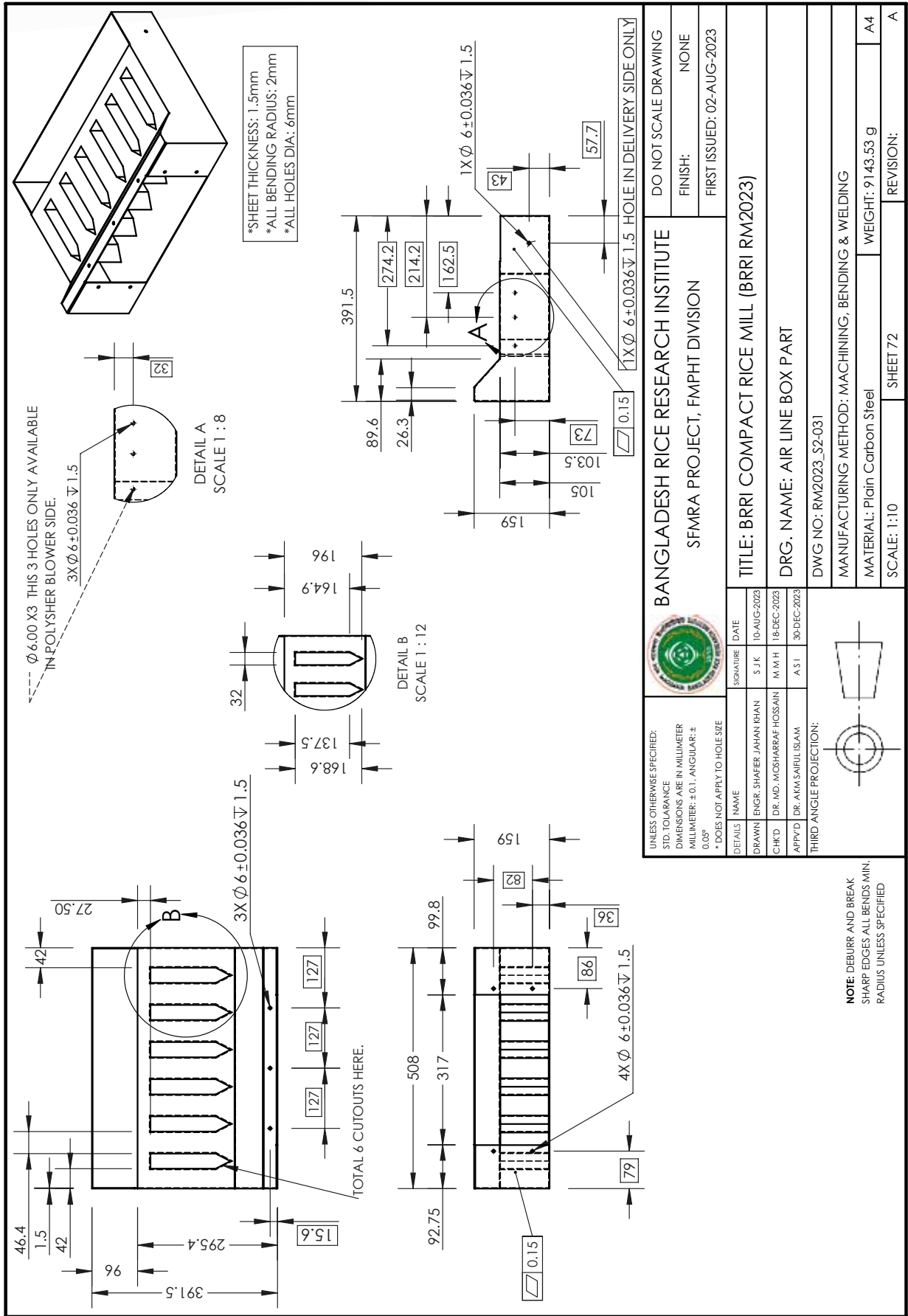
		BANGLADESH RICE RESEARCH INSTITUTE SFMRA PROJECT, FMPHT DIVISION		DO NOT SCALE DRAWING
UNLESS OTHERWISE SPECIFIED: STD. TOLERANCE DIMENSIONS ARE IN MILLIMETER MILLIMETER: ±0.1, ANGULAR: ±0.05° * DOES NOT APPLY TO HOLE SIZE		DRAWN ENGR. SHAFER JAHAN KHAN CHK'D DR. MD. MOSHARRAF HOSSAIN APP'VD DR. AKM SAIBUL ISLAM	DATE 10-AUG-2023 M M H 18-DEC-2023 A S I 30-DEC-2023	FINISH: NONE FIRST ISSUED: 02-AUG-2023
TITLE: BRI COMPACT RICE MILL (BRI RM2023)		DRG. NAME: MAIN BODY SHELL FLANGE - 2		
DWG NO: RM2023_S2-030		MANUFACTURING METHOD: MACHINING & WELDING		
THIRD ANGLE PROJECTION: 		MATERIAL: Plain Carbon Steel		
NOTE: DEBURR AND BREAK SHARP EDGES ALL BENDS MIN. RADIUS UNLESS SPECIFIED		WEIGHT: 3817.05 g		
SCALE: 1:4		SHEET 71		
REVISION:		A		



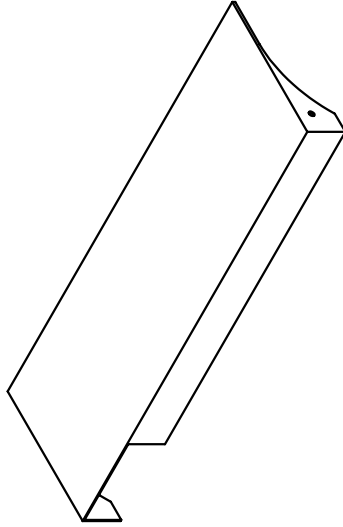
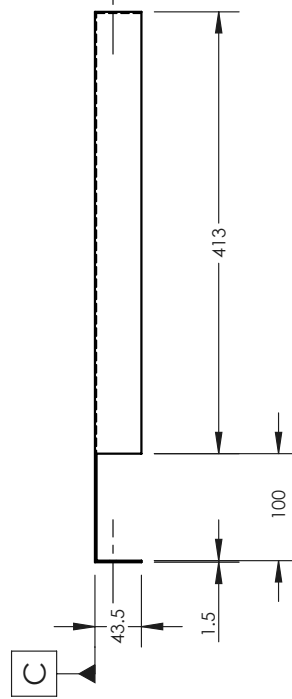
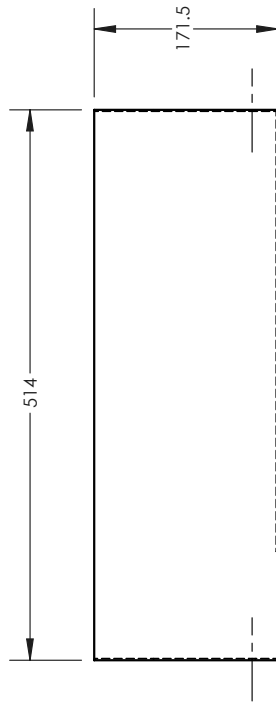

		BANGLADESH RICE RESEARCH INSTITUTE SFMRA PROJECT, FMPHT DIVISION		DO NOT SCALE DRAWING
FINISH: NONE		FIRST ISSUED: 02-AUG-2023		TITLE: BRRI COMPACT RICE MILL (BRRI RM2023)
DRG. NAME: AIR LINE BOX PART		DWG NO: RM2023_S2-031		MANUFACTURING METHOD: MACHINING, BENDING & WELDING
MATERIAL: Plain Carbon Steel		SCALE: 1:10		WEIGHT: 9143.53 g
SHEET 72		REVISION:		A

NOTE: DEBURR AND BREAK SHARP EDGES ALL BENDS MIN. RADIUS UNLESS SPECIFIED

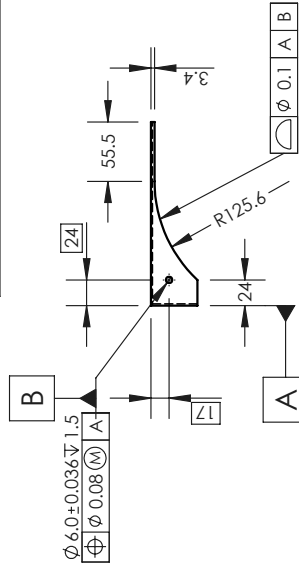

*SHEET SIZE 1.5mm
 *ONLY ONE SIDE HOLE SIZES HAS SHOWN HERE.
 *ANOTHER SIDE HOLE SIZES ARE SYMMETRY
 WITH TOLARANCE.
 *ALL BENDING RADIUS: 2mm

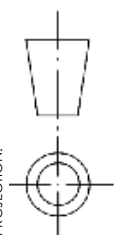

UNLESS OTHERWISE SPECIFIED: STD. TOLERANCE DIMENSIONS ARE IN MILLIMETER MILLIMETER: ± 0.1 , ANGULAR: $\pm 0.05^\circ$ * DOES NOT APPLY TO HOLE SIZE		 BANGLADESH RICE RESEARCH INSTITUTE SFMRA PROJECT, FMPHT DIVISION		DO NOT SCALE DRAWING
DETAILS		NAME	SIGNATURE	DATE
DRAWN		ENGR. SHAFER JAHAN KHAN	S. J.K	10-AUG-2023
CHK'D		DR. MD. MOSHARRAF HOSSAIN	M. M.H	18-DEC-2023
APP'VD		DR. AKM SAIFULL ISLAM	A. S.I	30-DEC-2023
THIRD ANGLE PROJECTION:				
TITLE: BRRI COMPACT RICE MILL (BRRI RM2023) DRG. NAME: MAIN BODY REAR CASING PART - 3 DWG NO: RM2023_S2-032 MANUFACTURING METHOD: MACHINING, BENDING & WELDING MATERIAL: Plain Carbon Steel SCALE: 1:6 WEIGHT: 1289.46 g REVISION: A				
FINISH: NONE		FIRST ISSUED: 02-AUG-2023		
SHEET 73		A4		

NOTE: DEBURR AND BREAK
 SHARP EDGES ALL BENDS MIN.
 RADIUS UNLESS SPECIFIED

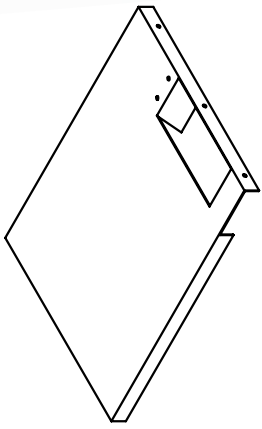

*THICKNESS 1.5mm.
 *DIA 6mm, BOTH SIDE HOLES CONTAINING SAME SIZE.
 SYMMETRY FOR HOLES.
 *ALL BENDING RADIUS: 2mm.

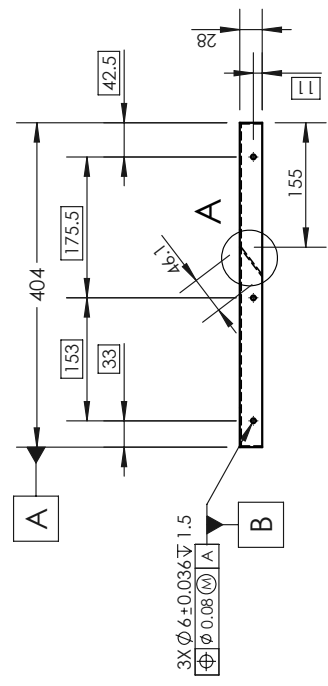
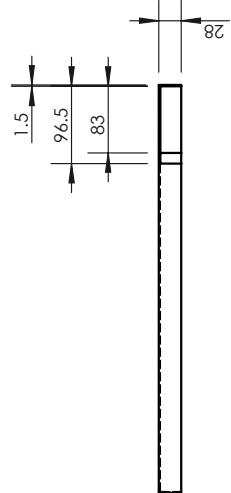
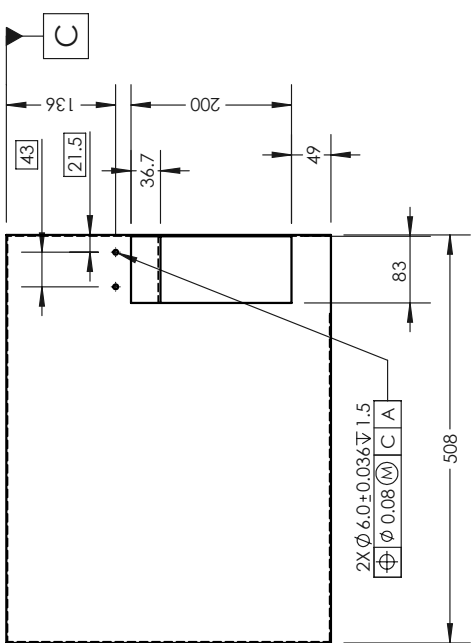
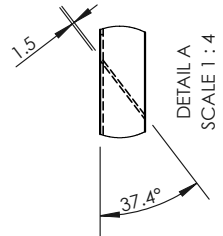

BANGLADESH RICE RESEARCH INSTITUTE
 SFMRA PROJECT, FMPHT DIVISION

DO NOT SCALE DRAWING
 FINISH: NONE
 FIRST ISSUED: 02-AUG-2023

TITLE: BRRI COMPACT RICE MILL (BRRI RM2023)

DRG. NAME: MAIN BODY REAR CASING PART - 4

DWG NO: RM2023_S2-033

MANUFACTURING METHOD: MACHINING, BENDING & WELDING

MATERIAL: Plain Carbon Steel

SCALE: 1:8 SHEET 74 REVISION: A

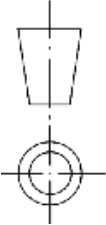

NOTE: DEBURR AND BREAK
 SHARP EDGES ALL BENDS MIN.
 RADIUS UNLESS SPECIFIED

UNLESS OTHERWISE SPECIFIED:
 STD. TOLERANCE
 DIMENSIONS ARE IN MILLIMETER
 MILLIMETER: ±0.1, ANGULAR: ±
 0.05°
 * DOES NOT APPLY TO HOLE SIZE

DETAILS	NAME	SIGNATURE	DATE
DRAWN	ENGR. SHAFER JAHAN RHAN	S J K	10-AUG-2023
CHK'D	DR. MD. MOSHARRAF HOSSAIN	M M H	18-DEC-2023
APP'D	DR. AKM SAIFUL ISLAM	A S I	30-DEC-2023

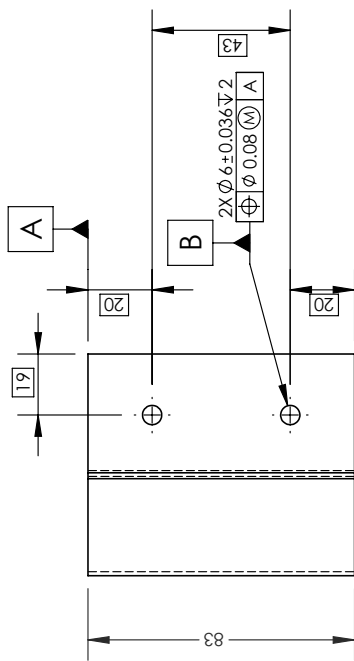

*THICKNESS 2mm.
 *DIA 6mm ALL HOLES.
 *BENDING RADIUS: 3mm.

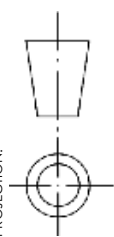
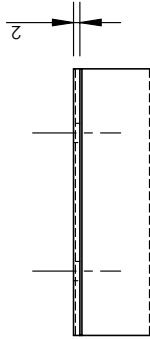
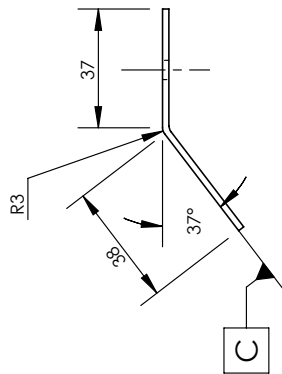
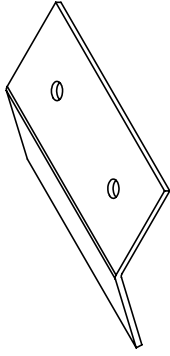

NOTE: DEBURR AND BREAK
 SHARP EDGES ALL BENDS MIN.
 RADIUS UNLESS SPECIFIED

		BANGLADESH RICE RESEARCH INSTITUTE SFMRA PROJECT, FMPHT DIVISION		DO NOT SCALE DRAWING
UNLESS OTHERWISE SPECIFIED: STD. TOLERANCE DIMENSIONS ARE IN MILLIMETER MILLIMETER: ±0.1, ANGULAR: ± 0.05° * DOES NOT APPLY TO HOLE SIZE		SIGNATURE S. J. K.	DATE 10-AUG-2023	FINISH: NONE
DRAWN ENGR. SHAFER JAHAN RHAN	M. M. H.	DATE 18-DEC-2023	FIRST ISSUED: 02-AUG-2023	
CHK'D DR. MD. MOSHARRAF HOSSAIN	A. S. I.	DATE 30-DEC-2023	TITLE: BRRI COMPACT RICE MILL (BRRI RM2023)	
APP'VD DR. AKM SAIEUL ISLAM		DRG. NAME: MAIN BODY REAR CASING PART - 4.1		
THIRD ANGLE PROJECTION:		DWG NO: RM2023_S2-034		
MANUFACTURING METHOD: MACHINING & BENDING				
MATERIAL: Plain Carbon Steel			WEIGHT: 97.94 g	A4
SCALE: 1:2			SHEET 75	REVISION: A

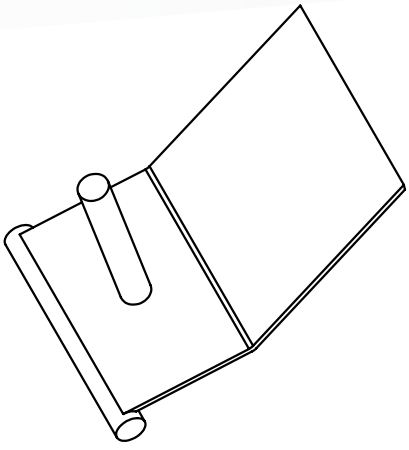

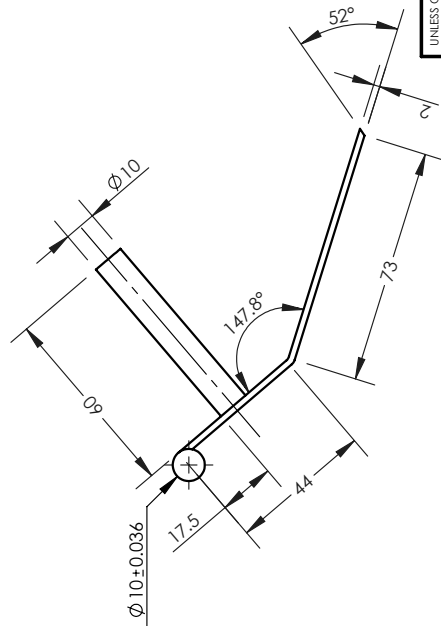
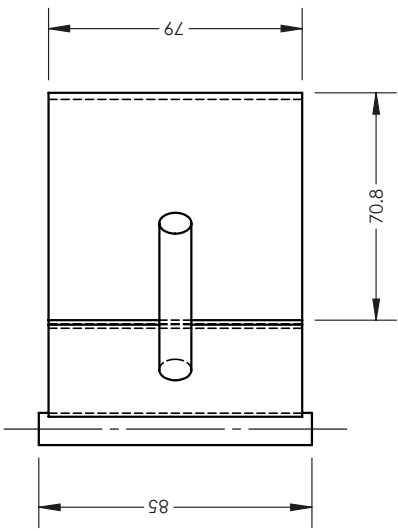
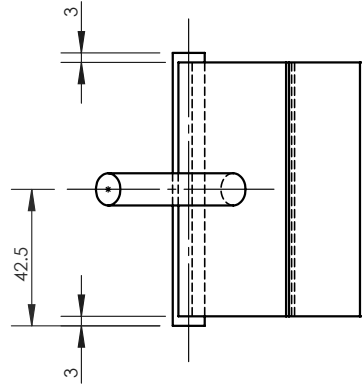

*THICKNESS 2mm
*ALL BENDING RADIUS: 3mm

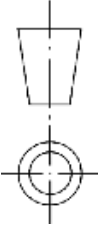

NOTE: DEBURR AND BREAK SHARP EDGES ALL BENDS MIN. RADIUS UNLESS SPECIFIED

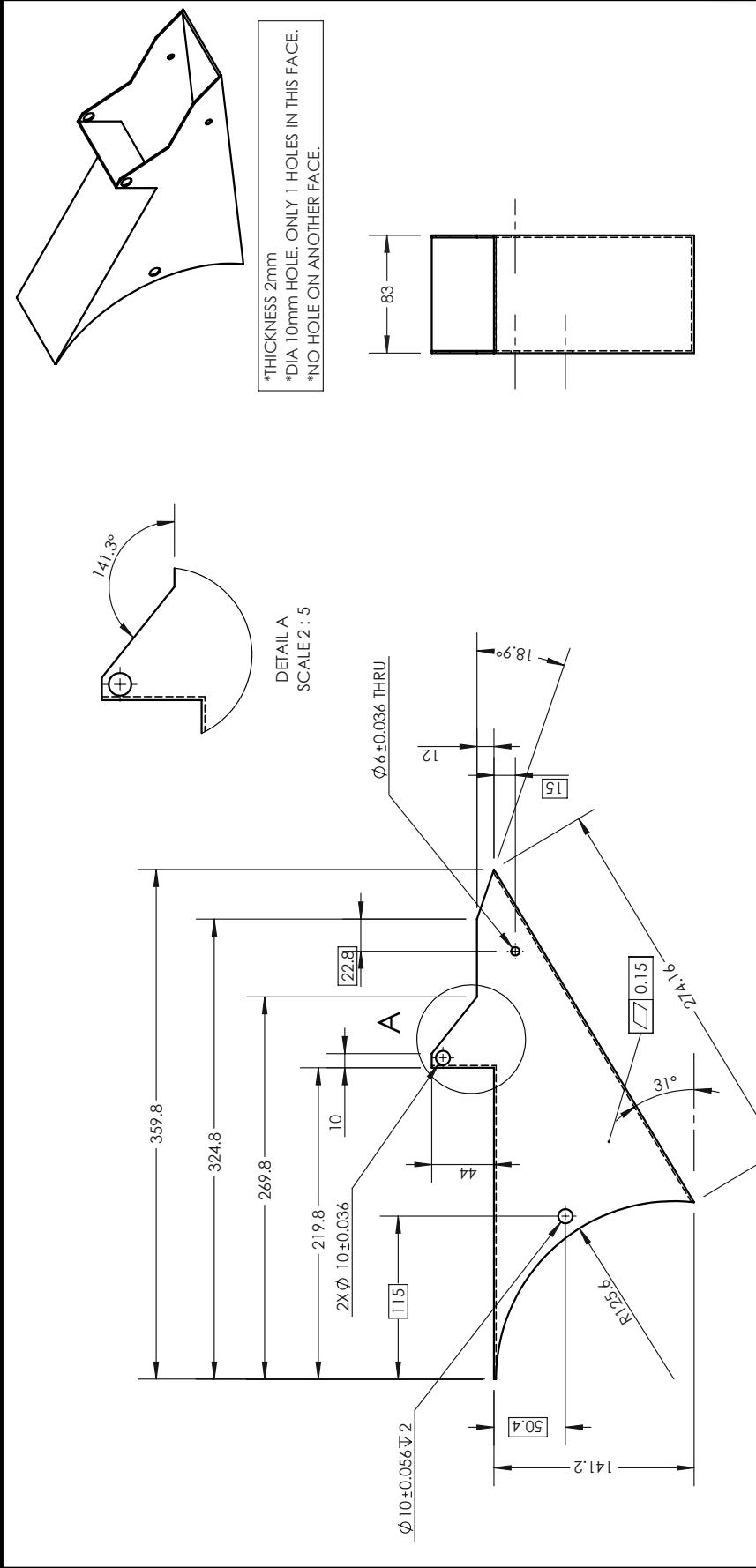
		BANGLADESH RICE RESEARCH INSTITUTE SFMRA PROJECT, FMPHT DIVISION		DO NOT SCALE DRAWING
UNLESS OTHERWISE SPECIFIED: STD. TOLERANCE DIMENSIONS ARE IN MILLIMETER MILLIMETER: ±0.1, ANGULAR: ±0.05° * DOES NOT APPLY TO HOLE SIZE		SIGNATURE S. J.K.	DATE 10-AUG-2023	FINISH: NONE
DRAWN ENGR. SHAFER JAHAN RHAN	M.M.H.	DATE 18-DEC-2023	TITLE: BRRI COMPACT RICE MILL (BRRI RM2023)	
CHK'D DR. MD. MOSHARRAF HOSSAIN	A.S.I.	DATE 30-DEC-2023	DRG. NAME: HUSK OUTPUT LINE PART-02	
APP'D DR. AKM SAIFUL ISLAM	THIRD ANGLE PROJECTION: 		DWG NO: RM2023_s2-035	
MANUFACTURING METHOD: MACHINING, BENDING & WELDING			MATERIAL: ASTM A36 Steel	
SCALE: 1:2			SHEET: 76	REVISION: A
WEIGHT: 234.52 g			A4	

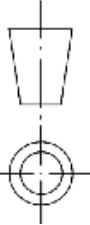

UNLESS OTHERWISE SPECIFIED: STD. TOLERANCE DIMENSIONS ARE IN MILLIMETER MILLIMETER: ±0.1, ANGULAR: ± 0.08° * DOES NOT APPLY TO HOLE SIZE				BANGLADESH RICE RESEARCH INSTITUTE SFMRA PROJECT, FMPHT DIVISION		DO NOT SCALE DRAWING	
DETAILS	NAME	SIGNATURE	DATE	TITLE: BRRI COMPACT RICE MILL (BRRI RM2023)		FINISH: NONE	
DRAWN	ENGR. SHAFER JAHAN RHAN	S J K	12-AUG-2023	DRG. NAME: HUSK OUTPUT LINE PART-01		FIRST ISSUED: 02-AUG-2023	
CHK'D	DR. MD. MOSHARRAF HOSSAIN	M M H	18-DEC-2023	DWG NO: RM2023_S2-036			
APP'VD	DR. AKM SAIFUL ISLAM	A S I	30-DEC-2023	MANUFACTURING METHOD: MACHINING & WELDING			
THIRD ANGLE PROJECTION:							
NOTE: DEBURR AND BREAK SHARP EDGES ALL BENDS MIN. RADIUS UNLESS SPECIFIED				MATERIAL: Plain Carbon Steel		WEIGHT: 1025.43 g	
				SCALE: 1:4		REVISION: A	
				SHEET 77			

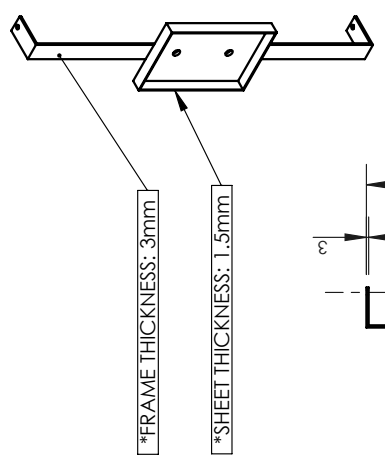
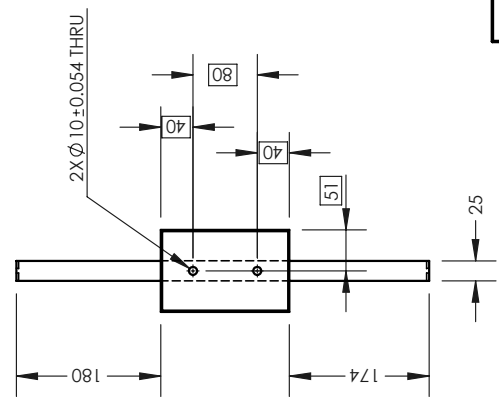
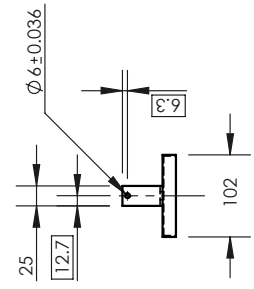

NOTE: DEBURR AND BREAK SHARP EDGES ALL BENDS MIN. RADIUS UNLESS SPECIFIED



BANGLADESH RICE RESEARCH INSTITUTE
 SFMRA PROJECT, FMPHT DIVISION

TITLE: BRRI COMPACT RICE MILL (BRRI RM2023)

DRG. NAME: RUBBER ROLLER TRAY

DWG NO: RM2023_S2-037

MANUFACTURING METHOD: MACHINING, BENDING & WELDING

MATERIAL: ASTM A36 Steel

SCALE: 1:8

WEIGHT: 634.74 g

REVISION: A

DO NOT SCALE DRAWING

FINISH: NONE

FIRST ISSUED: 02-AUG-2023

DETAILS	NAME	SIGNATURE	DATE
DRAWN	ENGR. SHAFER JAHAN KHAN	S J K	10-AUG-2023
CHK'D	DR. MD. MOSHARRAF HOSSAIN	M M H	18-DEC-2023
APP'D	DR. AKM SAIFUL ISLAM	A S I	30-DEC-2023

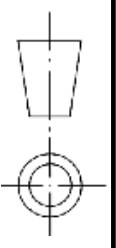

SHEET 78

A

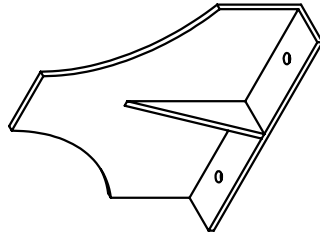
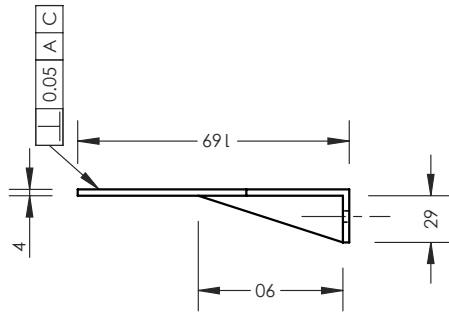
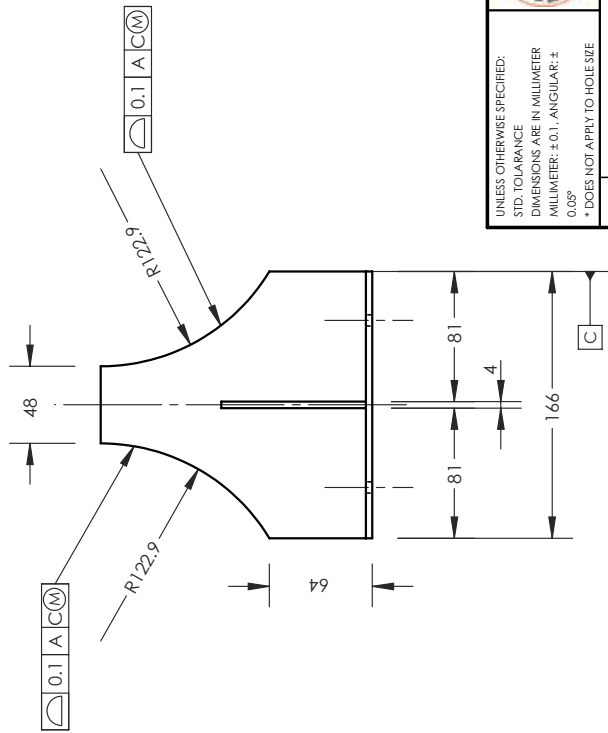
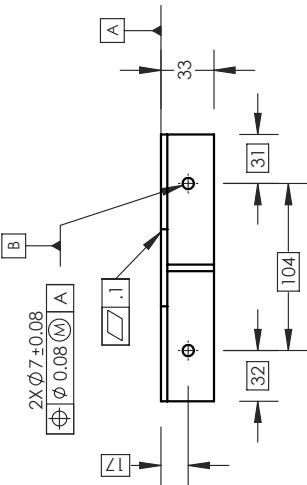

BANGLADESH RICE RESEARCH INSTITUTE
 SFMRA PROJECT, FMPHT DIVISION

TITLE: BRRI COMPACT RICE MILL (BRRI RM2023)

DRG. NAME: RUBBER ROLLER SUPPORT PART

DWG NO: RM2023_S2-038

MANUFACTURING METHOD: MACHINING & WELDING

MATERIAL: Plain Carbon Steel

SCALE: 1:4

WEIGHT: 790.48 g

REVISION: A

UNLESS OTHERWISE SPECIFIED:
 STD. TOLERANCE DIMENSIONS ARE IN MILLIMETER
 MILLIMETER: ±0.1, ANGULAR: ±0.05°
 * DOES NOT APPLY TO HOLE SIZE

DETAILS	NAME	SIGNATURE	DATE
DRAWN	ENGR. SHAFER JAHAN KHAN	S J K	10-AUG-2023
CHK'D	DR. MD. MOSHARRAF HOSSAIN	M M H	18-DEC-2023
APP'VD	DR. AKM SAIFUL ISLAM	A S I	30-DEC-2023

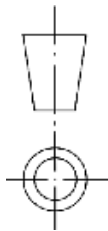

NOTE: DEBURR AND BREAK SHARP EDGES ALL BENDS MIN. RADIUS UNLESS SPECIFIED

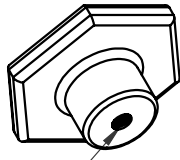

*MATRIX THREAD M10X1.5

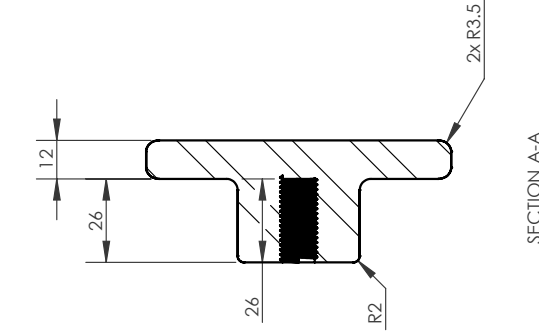

SECTION A-A

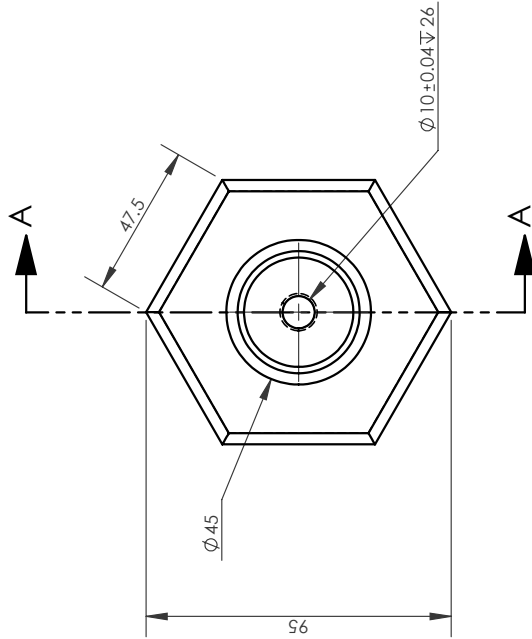

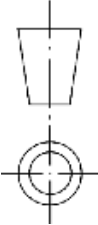
UNLESS OTHERWISE SPECIFIED: STD. TOLERANCE DIMENSIONS ARE IN MILLIMETER MILLIMETER: ±0.1, ANGULAR: ±0.05° * DOES NOT APPLY TO HOLE SIZE				BANGLADESH RICE RESEARCH INSTITUTE SFMRA PROJECT, FMPHT DIVISION		DO NOT SCALE DRAWING	
DETAILS		NAME	SIGNATURE	DATE	FINISH: NONE		
DRAWN		ENGR. SHAFER JAHAN RHAN	S. J.K	10-AUG-2023	FIRST ISSUED: 02-AUG-2023		
CHK'D	DR. MD. MOSHARRAF HOSSAIN	M. M.H		18-DEC-2023	TITLE: BRRI COMPACT RICE MILL (BRRI RM2023)		
APP'D	DR. AKM SAIBUL ISLAM	A.S.I		30-DEC-2023	DRG. NAME: BODY WINDOW LOCK		
THIRD ANGLE PROJECTION:							
				DWG NO: RM2023_S2-040		MANUFACTURING METHOD: MACHINING & WELDING	
NOTE: DEBURR AND BREAK SHARP EDGES ALL BENDS MIN. RADIUS UNLESS SPECIFIED				MATERIAL: ASTM A36 Steel		WEIGHT: 755.45 g	
				SCALE: 1:2		REVISION: A	
				SHEET 80		A	

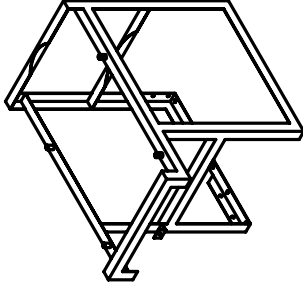
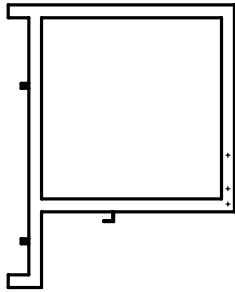
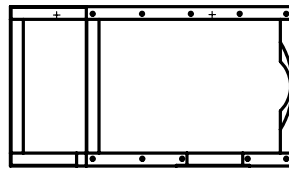
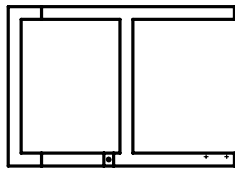
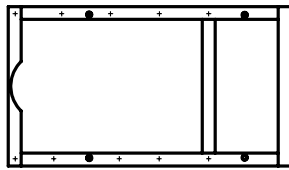

*FRAME PROFILE IS: ANGLE BAR (50X50X3) mm.

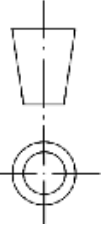
UNLESS OTHERWISE SPECIFIED: STD. TOLERANCE DIMENSIONS ARE IN MILLIMETER MILLIMETER: ±0.1, ANGULAR: ± 0.05° * DOES NOT APPLY TO HOLE SIZE				BANGLADESH RICE RESEARCH INSTITUTE SFMRA PROJECT, FMPHT DIVISION		DO NOT SCALE DRAWING	
DETAILS		NAME	SIGNATURE	DATE	FINISH: NONE		
DRAWN		ENGR. SHAFER JAHAN RHAN	S J K	12-AUG-2023	FIRST ISSUED: 02-AUG-2023		
CHK'D	DR. MD. MOSHARRAF HOSSAIN	M M H		18-DEC-2023	TITLE: BRRI COMPACT RICE MILL (BRRI RM2023)		
APP'VD	DR. AKM SAIBUL ISLAM	A S I		30-DEC-2023	DRG. NAME: NET FRAME CHALUNI WELDMENTS BODY FRAME		
THIRD ANGLE PROJECTION:							
		DWG NO: RM2023_S3-41					
MANUFACTURING METHOD: MACHINING, BENDING & WELDING							
MATERIAL: Plain Carbon Steel				WEIGHT: 13899.62 g		A4	
SCALE: 1:20				SHEET 81		REVISION: A	

NOTE: DEBURR AND BREAK SHARP EDGES ALL BENDS MIN. RADIUS UNLESS SPECIFIED

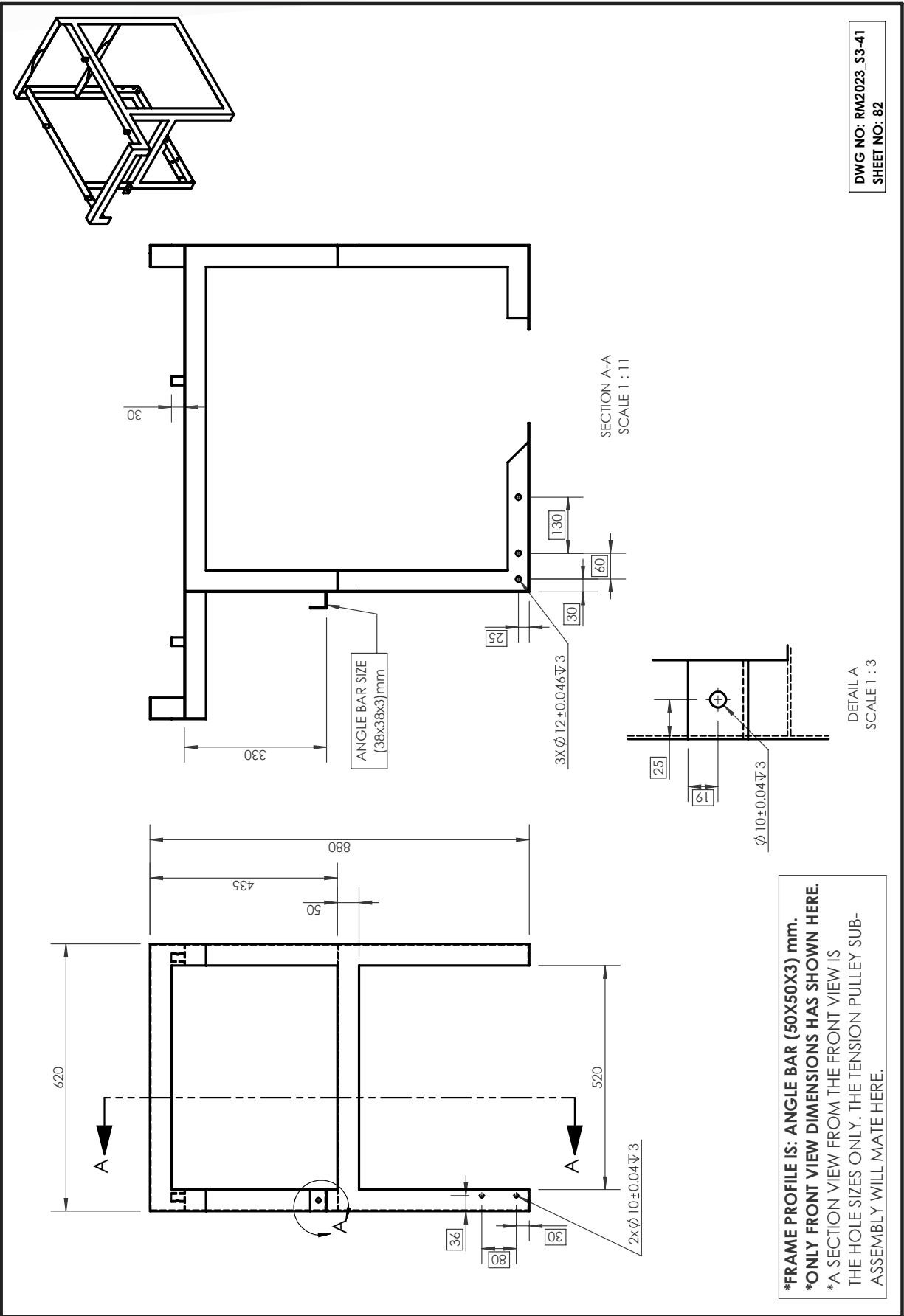

DWG NO: RM2023_s3-41
SHEET NO: 82

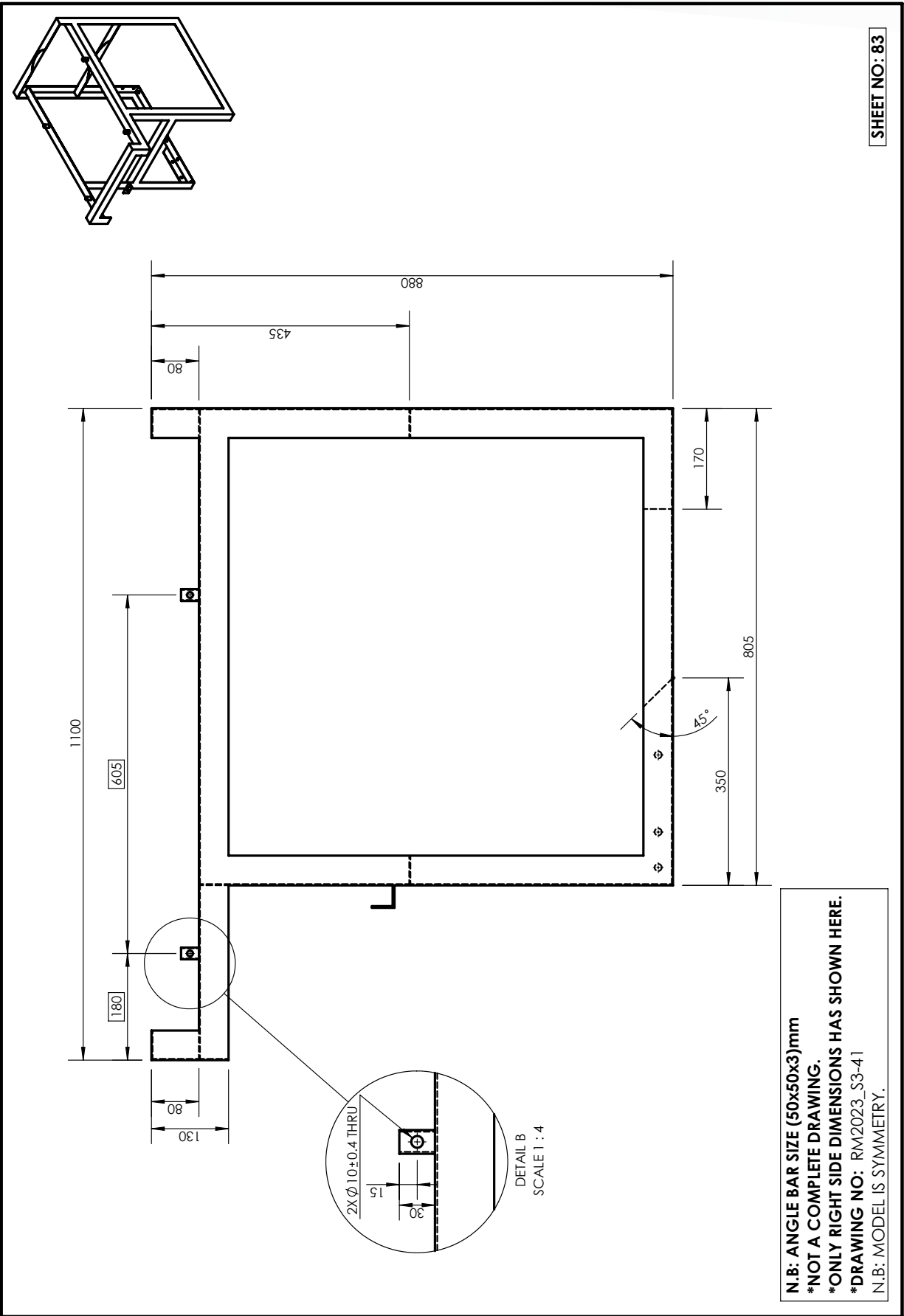

SHEET NO: 83

N.B: ANGLE BAR SIZE (50x50x3)mm
 *NOT A COMPLETE DRAWING.
 *ONLY RIGHT SIDE DIMENSIONS HAS SHOWN HERE.
 *DRAWING NO: RM2023_S3-41
 N.B: MODEL IS SYMMETRY.

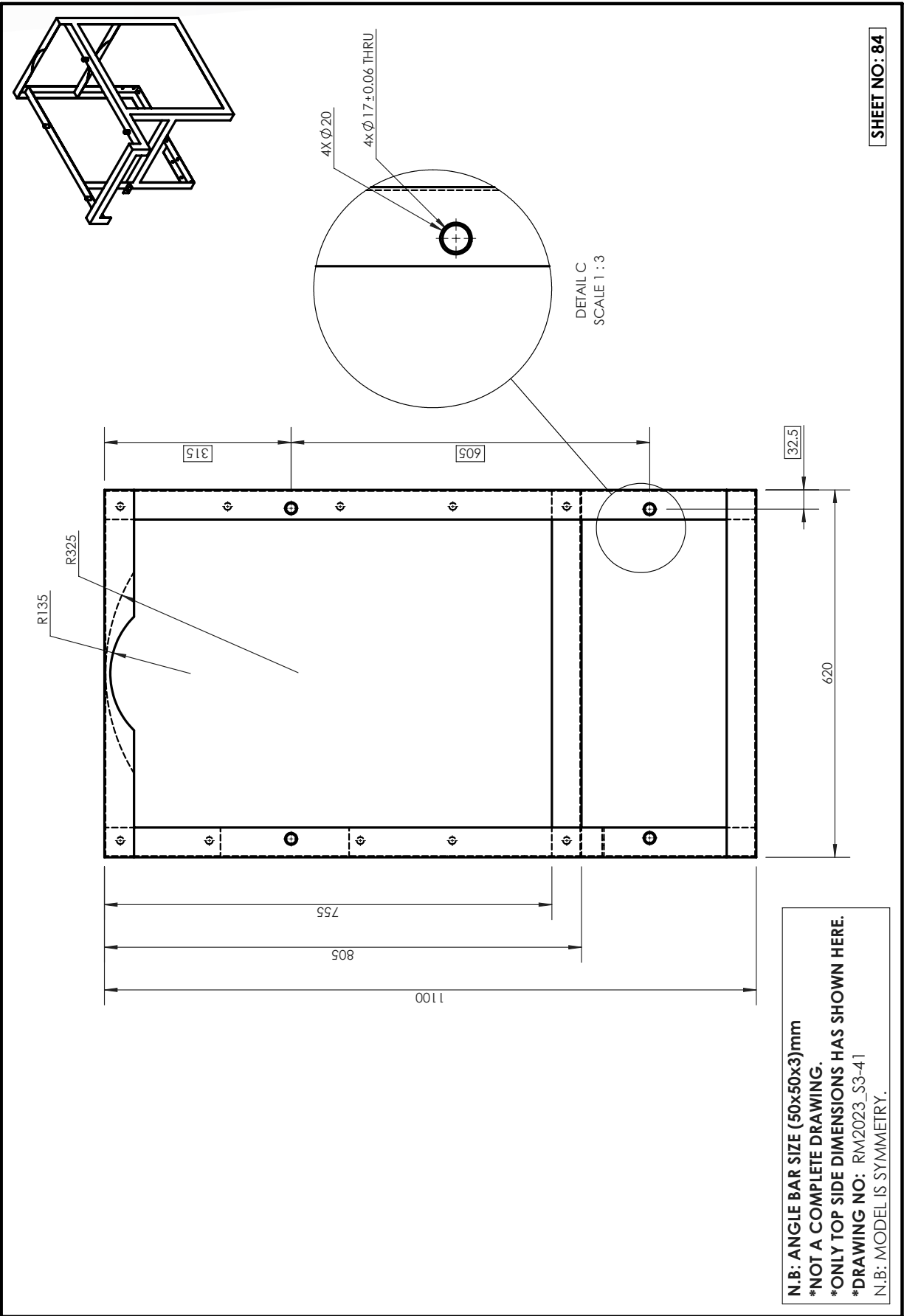

SHEET NO: 84

N.B: ANGLE BAR SIZE (50x50x3)mm
 *NOT A COMPLETE DRAWING.
 *ONLY TOP SIDE DIMENSIONS HAS SHOWN HERE.
 *DRAWING NO: RM2023_S3-41
 N.B: MODEL IS SYMMETRY.

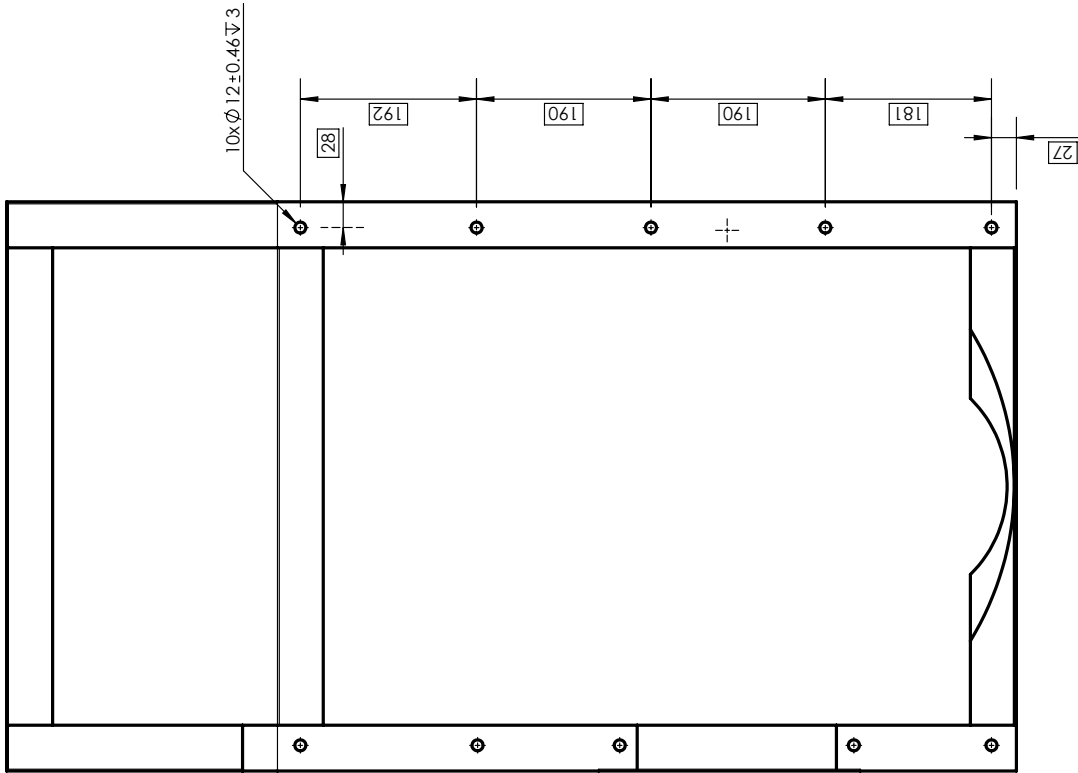
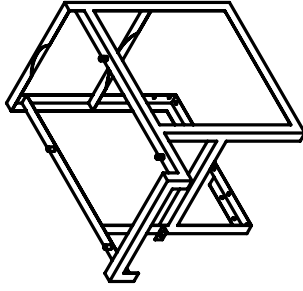

N.B.: ANGLE BAR SIZE (50x50x3)mm
*NOT A COMPLETE DRAWING.
*ONLY BOTTOM SIDE DIMENSIONS HAS SHOWN HERE.
*DRAWING NO: RM2023_S3-41
N.B.: MODEL IS SYMMETRY.

SHEET NO: 85

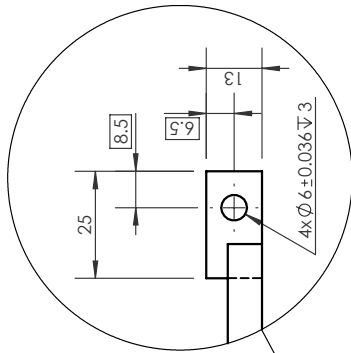
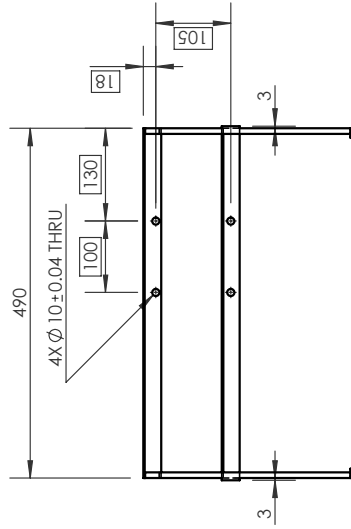
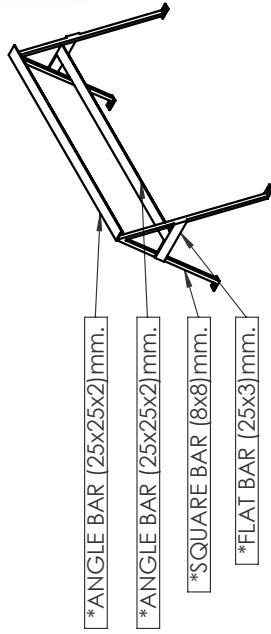

DETAIL A
 SCALE 2 : 3

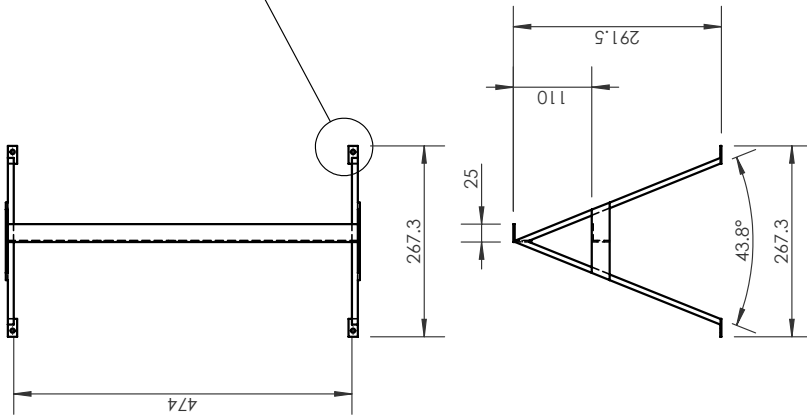

NOTE: DEBURR AND BREAK SHARP EDGES ALL BENDS MIN. RADIUS UNLESS SPECIFIED

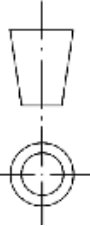
 BANGLADESH RICE RESEARCH INSTITUTE SFMRA PROJECT, FMPHT DIVISION		DO NOT SCALE DRAWING	
		FINISH: NONE	FIRST ISSUED: 02-AUG-2023
UNLESS OTHERWISE SPECIFIED: STD. TOLERANCE DIMENSIONS ARE IN MILLIMETER MILLIMETER: ±0.1, ANGULAR: ±0.05° * DOES NOT APPLY TO HOLE SIZE		TITLE: BRII COMPACT RICE MILL (BRII RM2023) DRG. NAME: PRE-CLEANER MOTOR CARRIER DWG NO: RM2023_S3-42	
DETAILS NAME DRAWN ENGR. SHAFER JAHAN KHAN CHK'D DR. MD. MOSHARRAF HOSSAIN APPVD DR. AKM SAIFUL ISLAM	SIGNATURE S J K M M H A S I	DATE 12-AUG-2023 18-OCT-2023 30-OCT-2023	MANUFACTURING METHOD: MACHINING, BENDING & WELDING MATERIAL: Plain Carbon Steel SCALE: 1:9 SHEET: 86
THIRD ANGLE PROJECTION: 		WEIGHT: 1412.37 g REVISION: A	

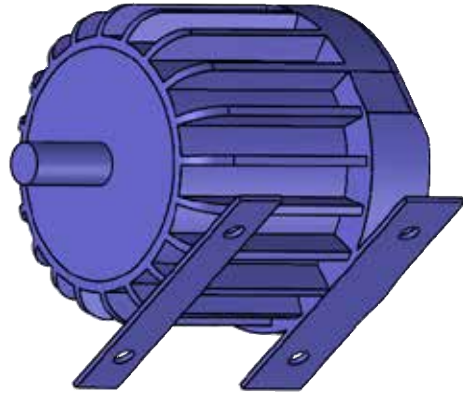

HORSEPOWER: 1 HP
 SPEED: 1450 RPM
 MOUNTING TYPE: BODY
 FREQUENCY: 50 Hz
 MATERIAL: CAST IRON

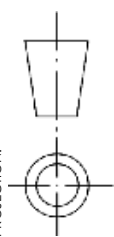
UNLESS OTHERWISE SPECIFIED: STD. TOLERANCE DIMENSIONS ARE IN MILLIMETER MILLIMETER: ±0.1, ANGULAR: ±0.05° * DOES NOT APPLY TO HOLE SIZE			BANGLADESH RICE RESEARCH INSTITUTE		DO NOT SCALE DRAWING
			SFMRA PROJECT, FMPHT DIVISION		FINISH: NONE FIRST ISSUED: 02-AUG-2023
DETAILS	NAME	SIGNATURE	DATE	TITLE: BRRI COMPACT RICE MILL (BRRI RM2023)	
DRAWN	ENGR. SHAFER JAHAN KHAN	S. J.K	12-AUG-2023	DRG. NAME: NET FRAME-MOTOR 1 HP	
CHK'D	DR. MD. MOSHARRAF HOSSAIN	M. M.H	18-DEC-2023	DWG NO: RM2023_S3-42	
APP'D	DR. AKM SAIBUL ISLAM	A.S.I	30-DEC-2023	FINDING PROCESS: SHOP	
THIRD ANGLE PROJECTION:					
NOTE: DEBURR AND BREAK SHARP EDGES ALL BENDS MIN. RADIUS UNLESS SPECIFIED			MATERIAL: Gray Cast Iron		WEIGHT: 58059.80 g
			SCALE: 1:3		SHEET 87

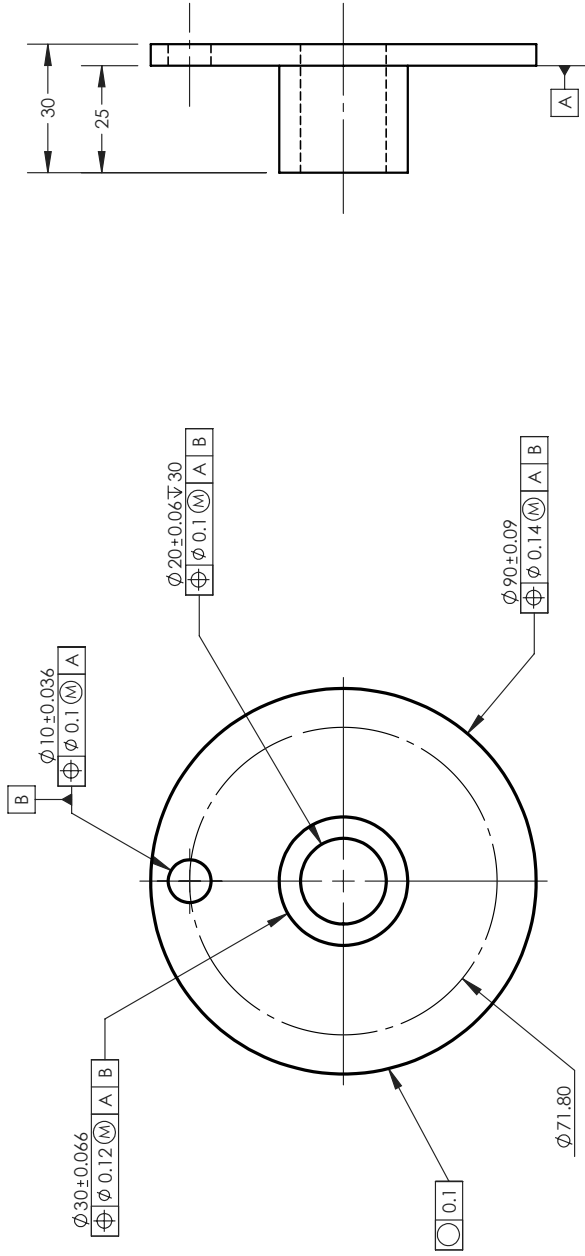
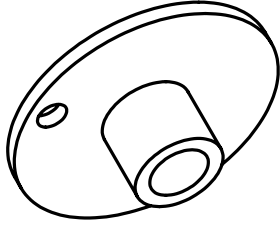

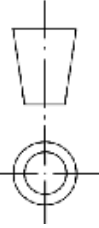

UNLESS OTHERWISE SPECIFIED: STD. TOLERANCE DIMENSIONS ARE IN MILLIMETER MILLIMETER: ± 0.1 , ANGULAR: $\pm 0.05^\circ$ * DOES NOT APPLY TO HOLE SIZE				BANGLADESH RICE RESEARCH INSTITUTE SFMRA PROJECT, FMPHT DIVISION		DO NOT SCALE DRAWING	
DETAILS		NAME	SIGNATURE	DATE	FINISH: NONE		
DRAWN		ENGR. SHAFER JAHAN RHAN	S. J.K	12-AUG-2023	FIRST ISSUED: 02-AUG-2023		
CHK'D		DR. MD. MOSHARRAF HOSSAIN	M. M.H	18-DEC-2023	TITLE: BRRI COMPACT RICE MILL (BRRI RM2023)		
APP'D		DR. AKM SAIBUL ISLAM	A.S.I	30-DEC-2023	DRG. NAME: CAM ADJUSTING PART		
THIRD ANGLE PROJECTION:							
				DWG NO: RM2023_S3-43			
MANUFACTURING METHOD: MACHINING							
MATERIAL: Plain Carbon Steel				SCALE: 2:3		SHEET: 88	
WEIGHT: 309.37 g				REVISION:		A	
				A4		A	

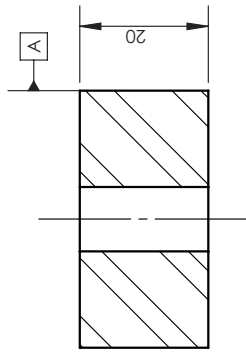
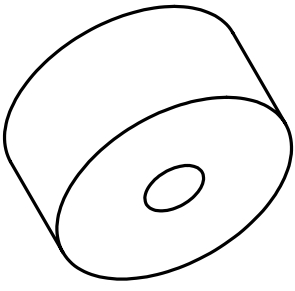
NOTE: DEBURR AND BREAK SHARP EDGES ALL BENDS MIN. RADIUS UNLESS SPECIFIED

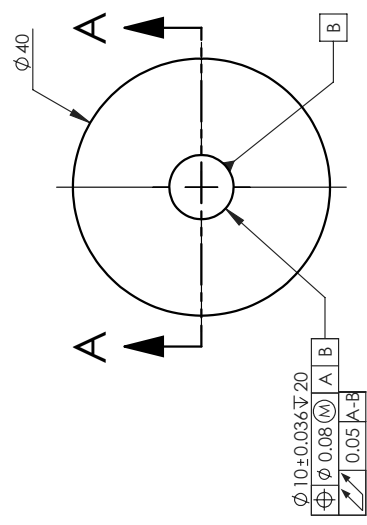

SECTION A-A

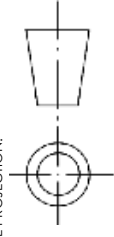

UNLESS OTHERWISE SPECIFIED: STD. TOLERANCE DIMENSIONS ARE IN MILLIMETER MILLIMETER: ±0.1, ANGULAR: ± 0.05° * DOES NOT APPLY TO HOLE SIZE				BANGLADESH RICE RESEARCH INSTITUTE SFMRA PROJECT, FMPHT DIVISION		DO NOT SCALE DRAWING	
DETAILS	NAME	SIGNATURE	DATE	TITLE: BRRI COMPACT RICE MILL (BRRI RM2023)			
DRAWN	ENGR. SHAFER JAHAN RHAN	S. J.K	12-AUG-2023	FINISH: NONE		FIRST ISSUED: 02-AUG-2023	
CHK'D	DR. MD. MOSHARRAF HOSSAIN	M. M.H	18-DEC-2023	DRG. NAME: CAM			
APP'VD	DR. AKM SAIFUL ISLAM	A.S.I	30-DEC-2023	DWG NO: RM2023_S3-44		REVISION: A	
THIRD ANGLE PROJECTION:				MANUFACTURING METHOD: MACHINING			
				MATERIAL: Plain Carbon Steel		WEIGHT: 183.78 g	
NOTE: DEBURR AND BREAK SHARP EDGES ALL BENDS MIN. RADIUS UNLESS SPECIFIED				SCALE: 1:1		SHEET 89	

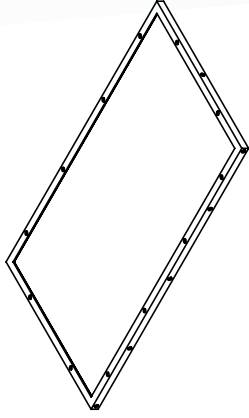
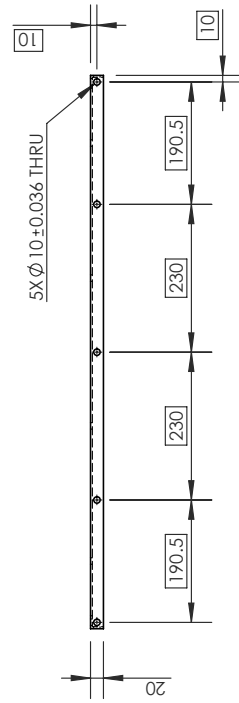
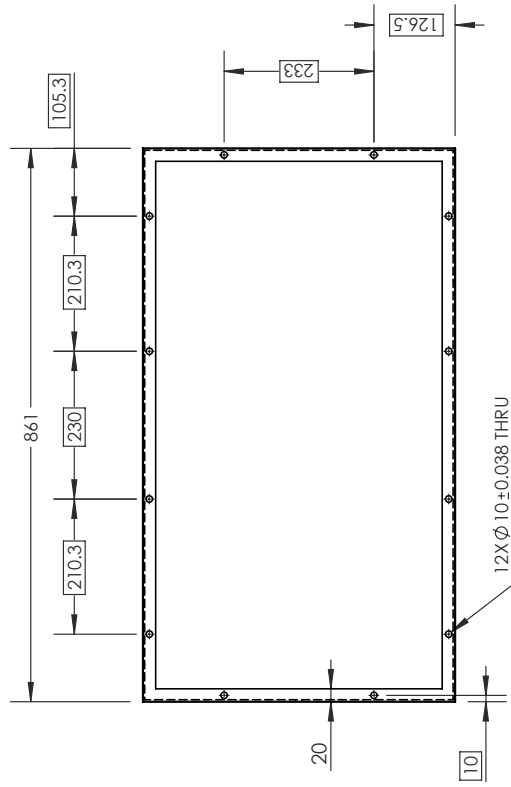

***TAKING 20mmx20mmx2mm ANGLE BAR.
 ***MODEL IS SYMMETRY. ONLY ONE SIDE/FACE
 SIZES HAS SHOWN.
 *** HOLES IN TOP: 12. HOLES IN FRONT & REAR: 5+5=10
 HOLES IN RIGHT & LEFT: 1+1=2. TOTAL 24 HOLES.

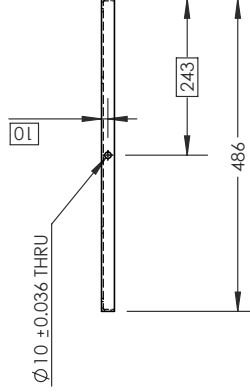

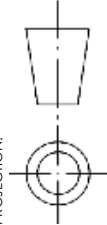
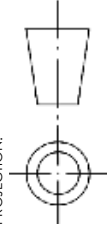
UNLESS OTHERWISE SPECIFIED: STD. TOLERANCE DIMENSIONS ARE IN MILLIMETER MILLIMETER: ±0.1, ANGULAR: ± 0.05° * DOES NOT APPLY TO HOLE SIZE				BANGLADESH RICE RESEARCH INSTITUTE SFMRA PROJECT, FMPHT DIVISION		DO NOT SCALE DRAWING	
DETAILS		NAME	SIGNATURE	DATE	FINISH: NONE		
DRAWN		ENGR. SHAFER JAHAN RHAN	S J K	12-AUG-2023	FIRST ISSUED: 02-AUG-2023		
CHK'D		DR. MD. MOSHARRAF HOSSAIN	M M H	18-DEC-2023	TITLE: BRRI COMPACT RICE MILL (BRRI RM2023)		
APP'VD		DR. AKM SAIBUL ISLAM	A S I	30-DEC-2023	DRG. NAME: CHALUNI-NET SUPPORT FRAME		
THIRD ANGLE PROJECTION:				DWG NO: RM2023_S3-45			
NOTE: DEBURR AND BREAK SHARP EDGES ALL BENDS MIN. RADIUS UNLESS SPECIFIED				MANUFACTURING METHOD: MACHINING, BENDING & WELDING			
				MATERIAL: Plain Carbon Steel		WEIGHT: 2246.14 g	
				SCALE: 1:10		SHEET 90	
						REVISION: A	

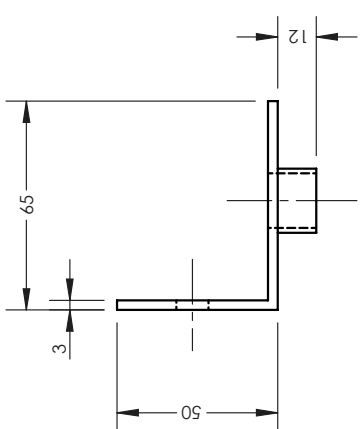
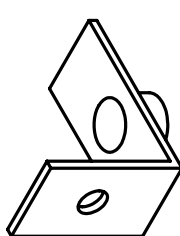
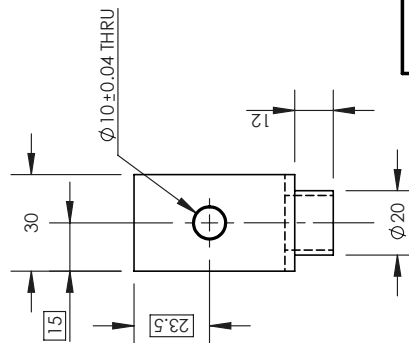
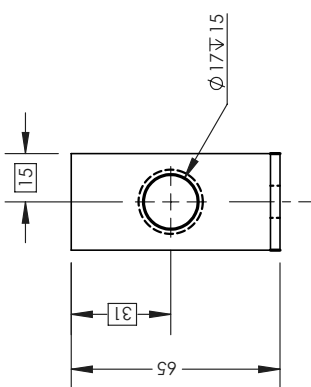

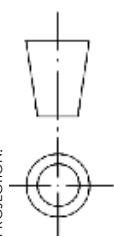
UNLESS OTHERWISE SPECIFIED: STD. TOLERANCE DIMENSIONS ARE IN MILLIMETER MILLIMETER: ±0.1, ANGULAR: ±0.05° * DOES NOT APPLY TO HOLE SIZE				BANGLADESH RICE RESEARCH INSTITUTE SFMRA PROJECT, FMPHT DIVISION		DO NOT SCALE DRAWING	
DETAILS	NAME	SIGNATURE	DATE	FINISH: NONE			
	ENGR. SHAFER JAHAN KHAN	S. J.K	12-AUG-2023	FIRST ISSUED: 02-AUG-2023			
CHK'D	DR. MD. MOSHARRAF HOSSAIN	M. M.H	18-DEC-2023	TITLE: BRRI COMPACT RICE MILL (BRRI RM2023)			
APP'D	DR. AKM SAIFUL ISLAM	A.S.I	30-DEC-2023	DRG. NAME: CHALUNI SUPPORT PART			
THIRD ANGLE PROJECTION:				DWG NO: RM2023_S3-46			
				MANUFACTURING METHOD: MACHINING & WELDING			
NOTE: DEBURR AND BREAK SHARP EDGES ALL BENDS MIN. RADIUS UNLESS SPECIFIED				MATERIAL: Plain Carbon Steel			
SCALE: 1:2				SHEET: 91		REVISION: A	
				WEIGHT: 79.63 g		A4	

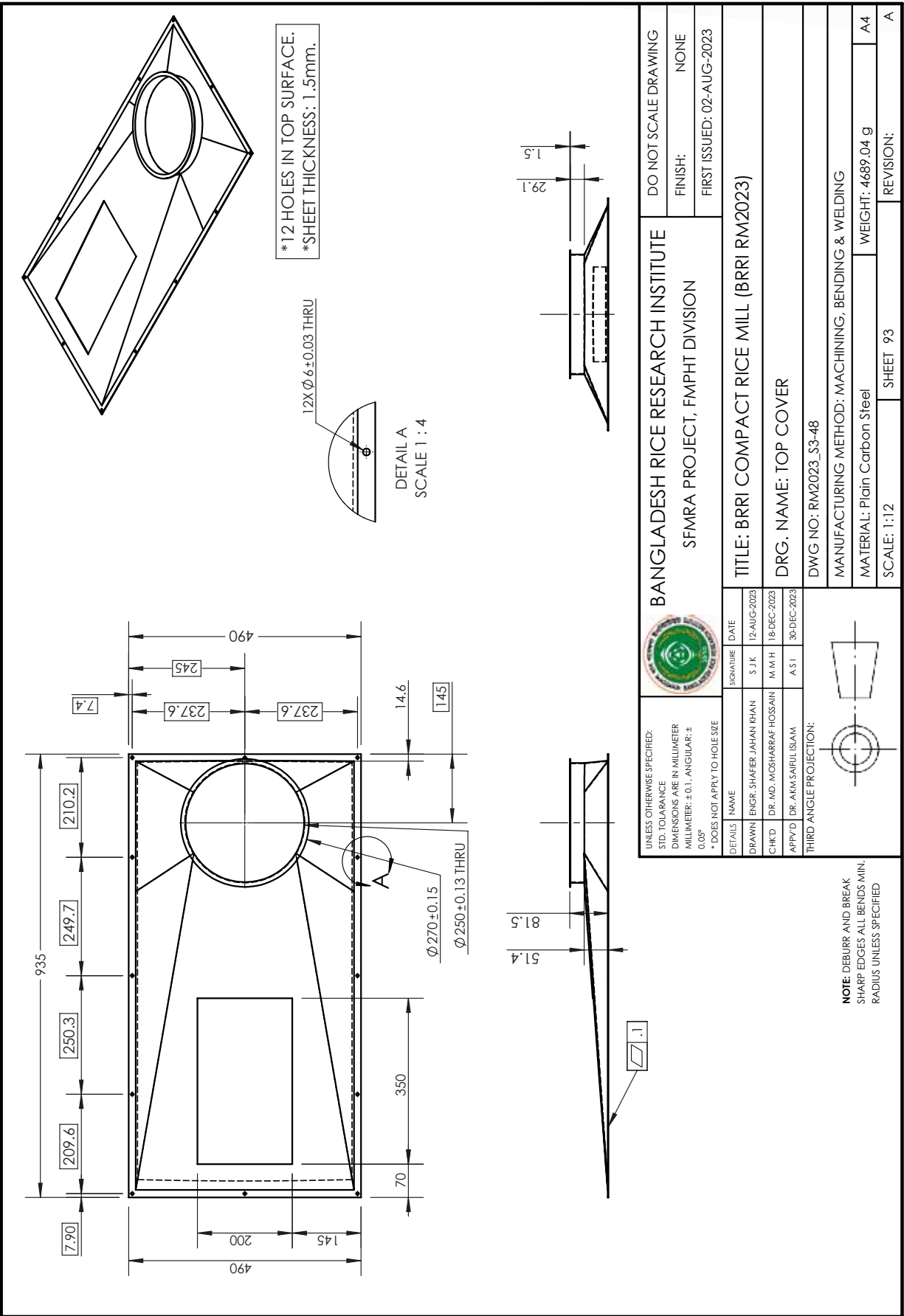

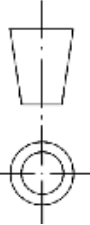
		BANGLADESH RICE RESEARCH INSTITUTE SFMRA PROJECT, FMPHT DIVISION		DO NOT SCALE DRAWING FINISH: NONE FIRST ISSUED: 02-AUG-2023	
UNLESS OTHERWISE SPECIFIED: STD. TOLERANCE DIMENSIONS ARE IN MILLIMETER MILLIMETER: ±0.1, ANGULAR: ±0.05° * DOES NOT APPLY TO HOLE SIZE		DETAILS NAME: ENGR. SHAFER JAHAN RHAN DRAWN: M M H APP'D: DR. AKM SAIBUL ISLAM	SIGNATURE S J K M M H A S I	DATE 12-AUG-2023 18-DEC-2023 30-DEC-2023	TITLE: BRRI COMPACT RICE MILL (BRRI RM2023) DRG. NAME: TOP COVER DWG NO: RM2023_S3-48
THIRD ANGLE PROJECTION:				MANUFACTURING METHOD: MACHINING, BENDING & WELDING MATERIAL: Plain Carbon Steel SCALE: 1:12 SHEET 93	
NOTE: DEBURR AND BREAK SHARP EDGES ALL BENDS MIN. RADIUS UNLESS SPECIFIED		WEIGHT: 4689.04 g REVISION: A		A4 A	

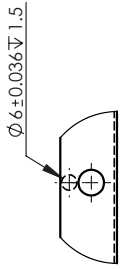
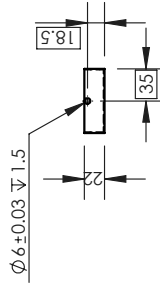
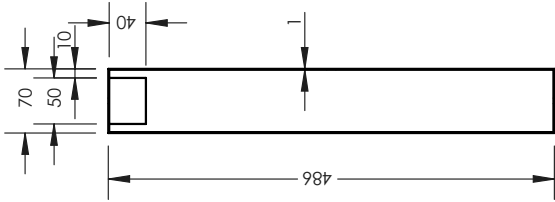

DETAIL A
SCALE 2 : 5

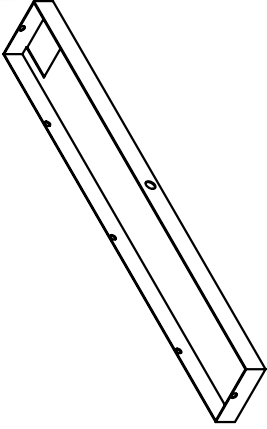

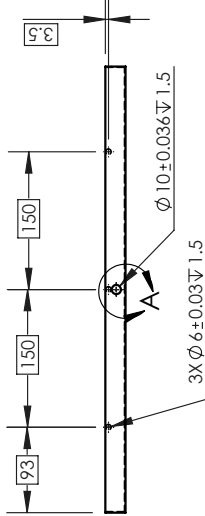

*HOLE SIZES FOR ANOTHER SIDE IS SYMMETRY.
*SHEET THICKNESS: 1mm
*BENDING RADIUS: 2mm

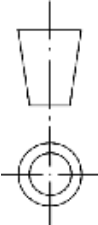

UNLESS OTHERWISE SPECIFIED: STD. TOLERANCE DIMENSIONS ARE IN MILLIMETER MILLIMETER: ±0.1, ANGULAR: ±0.05° * DOES NOT APPLY TO HOLE SIZE				BANGLADESH RICE RESEARCH INSTITUTE SFMRA PROJECT, FMPHT DIVISION		DO NOT SCALE DRAWING
DETAILS	NAME	SIGNATURE	DATE			FINISH: NONE
DRAWN	ENGR. SHAFER JAHAN KHAN	S J K	12-AUG-2023			FIRST ISSUED: 02-AUG-2023
CHK'D	DR. MD. MOSHARRAF HOSSAIN	M M H	18-DEC-2023			
APP'VD	DR. AKM SAIFUL ISLAM	A S I	30-DEC-2023			
THIRD ANGLE PROJECTION:						
TITLE: BRRI COMPACT RICE MILL (BRRI RM2023) DRG. NAME: CHALUNI BODY PART - 1 DWG NO: RM2023_S3-49 MANUFACTURING METHOD: MACHINING, BENDING & WELDING						
MATERIAL: Plain Carbon Steel				WEIGHT: 429.53 g		A4
SCALE: 1:7				SHEET 94		REVISION: A

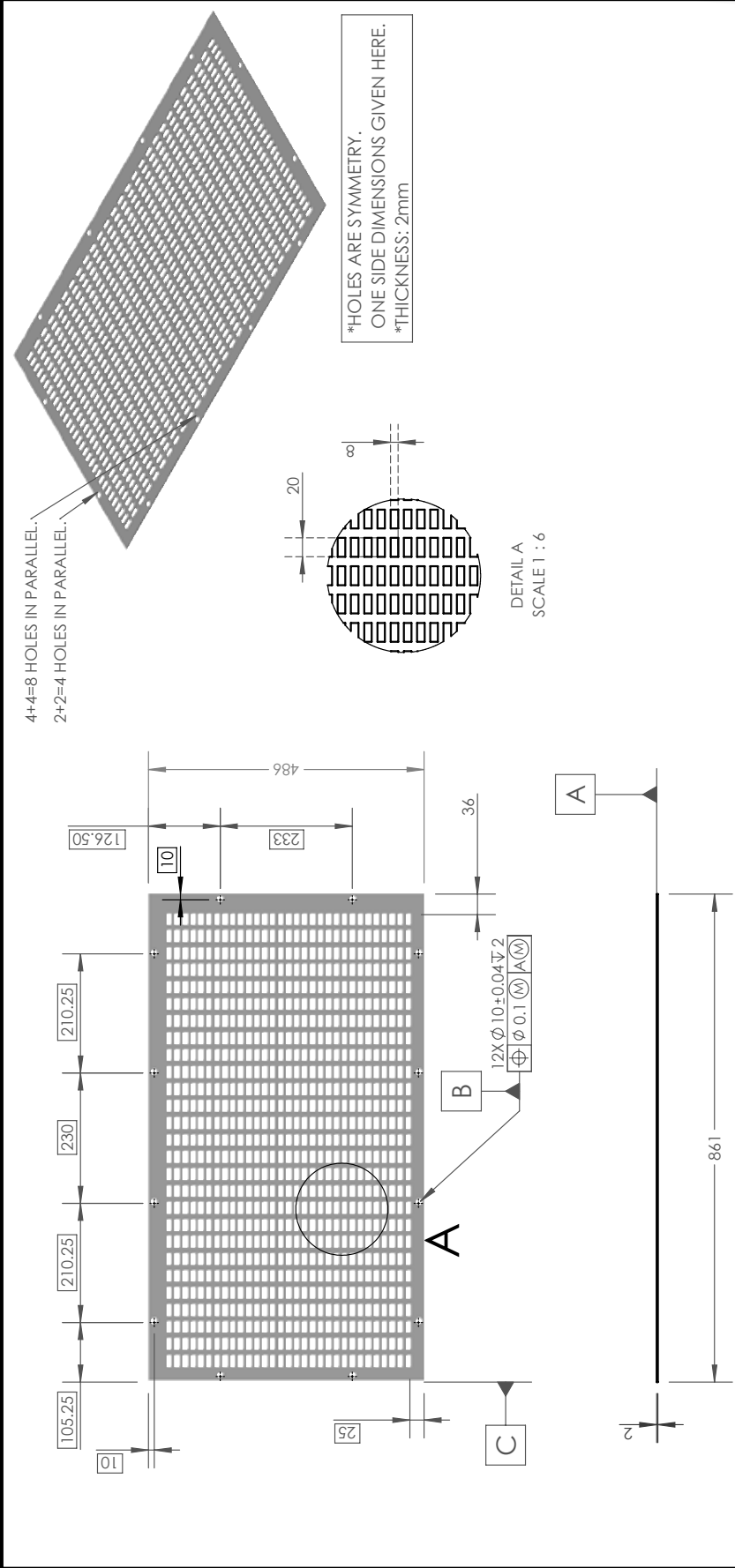
NOTE: DEBURR AND BREAK SHARP EDGES ALL BENDS MIN. RADIUS UNLESS SPECIFIED



		BANGLADESH RICE RESEARCH INSTITUTE SFMRA PROJECT, FMPHT DIVISION		DO NOT SCALE DRAWING	
UNLESS OTHERWISE SPECIFIED: STD. TOLERANCE DIMENSIONS ARE IN MILLIMETER MILLIMETER: ±0.1, ANGULAR: ±0.05° * DOES NOT APPLY TO HOLE SIZE		DETAILS NAME DRAWN ENGR. SHAFER JAHAN KHAN CHK'D DR. MD. MOSHARRAF HOSSAIN APP'VD DR. AKM SAIBUL ISLAM	SIGNATURE S J K M M H A S I	DATE 12-AUG-2023 18-DEC-2023 30-DEC-2023	FINISH: NONE FIRST ISSUED: 02-AUG-2023
TITLE: BRRI COMPACT RICE MILL (BRRI RM2023)					
DRG. NAME: METAL MESH NET					
DWG NO: RM2023_S3-50					
MANUFACTURING METHOD: MACHINING					
MATERIAL: STAINLESS STEEL (FERRITIC) 202 GRADE			WEIGHT: 4423.90 g		
SCALE: 1:10			SHEET 95		
REVISION: A			A4		

NOTE: DEBURR AND BREAK SHARP EDGES ALL BENDS MIN. RADIUS UNLESS SPECIFIED

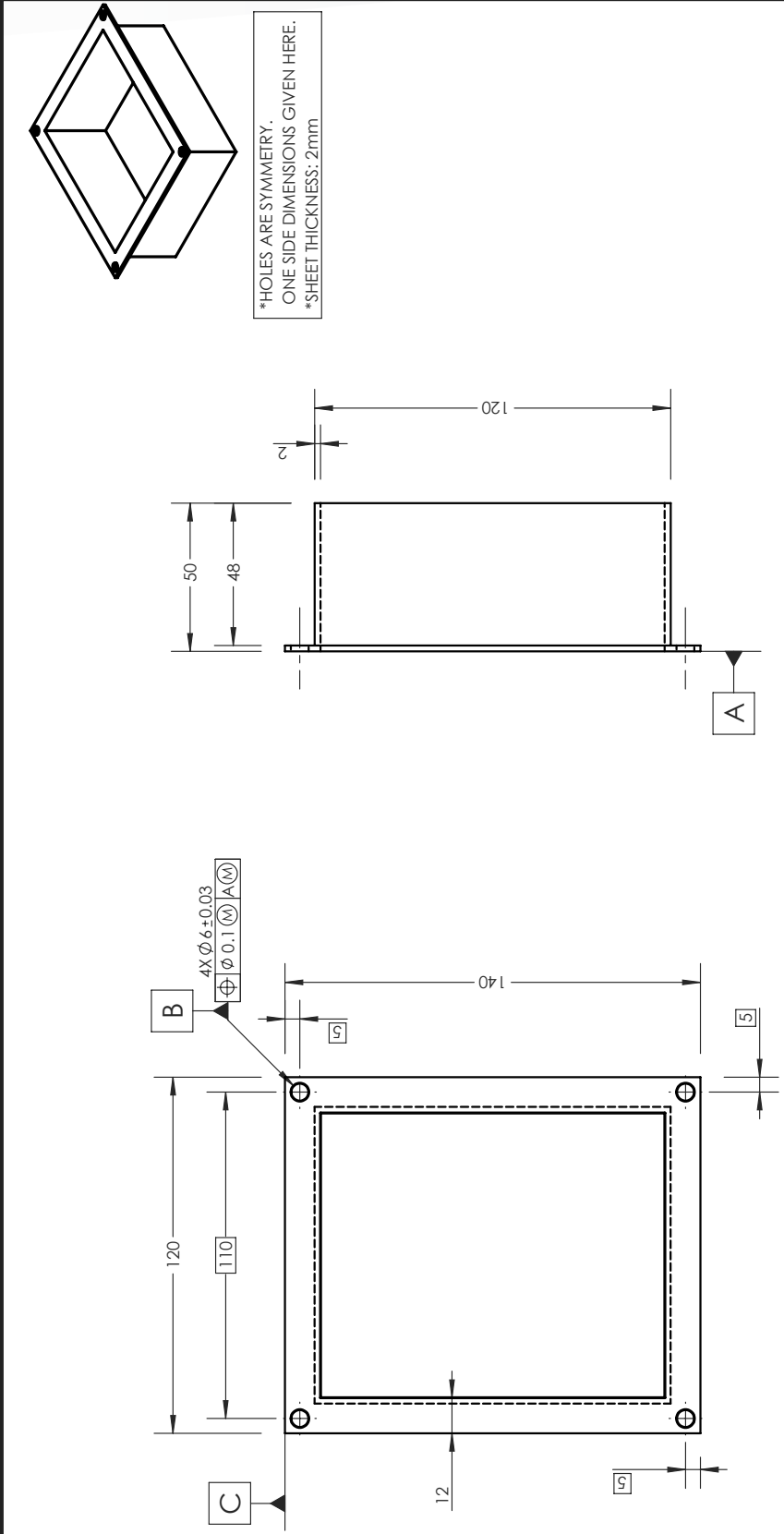

*HOLES ARE SYMMETRY.
 ONE SIDE DIMENSIONS GIVEN HERE.
 *SHEET THICKNESS: 2mm

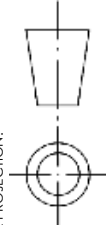
UNLESS OTHERWISE SPECIFIED: STD. TOLERANCE DIMENSIONS ARE IN MILLIMETER MILLIMETER: ±0.1, ANGULAR: ±0.05° * DOES NOT APPLY TO HOLE SIZE				BANGLADESH RICE RESEARCH INSTITUTE SFMRA PROJECT, FMPHT DIVISION		DO NOT SCALE DRAWING	
DETAILS		NAME	SIGNATURE	DATE	FINISH: NONE		
DRAWN		ENGR. SHAFER JAHAN KHAN	S. J.K	12-AUG-2023	FIRST ISSUED: 02-AUG-2023		
CHK'D		DR. MD. MOSHARRAF HOSSAIN	M. M.H	18-DEC-2023	TITLE: BRRI COMPACT RICE MILL (BRRI RM2023)		
APP'VD		DR. AKM SAIBUL ISLAM	A.S.I	30-DEC-2023	DRG. NAME: CLEAN PADDY OUTPUT GATE PART		
THIRD ANGLE PROJECTION:							
				DWG NO: RM2023_S3-53			
MANUFACTURING METHOD: MACHINING & WELDING							
MATERIAL: Plain Carbon Steel				WEIGHT: 410.08 g			
SCALE: 1:2				SHEET: 96		REVISION: A	

NOTE: DEBURR AND BREAK SHARP EDGES ALL BENDS MIN. RADIUS UNLESS SPECIFIED

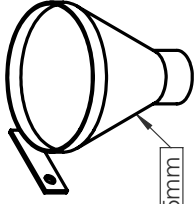
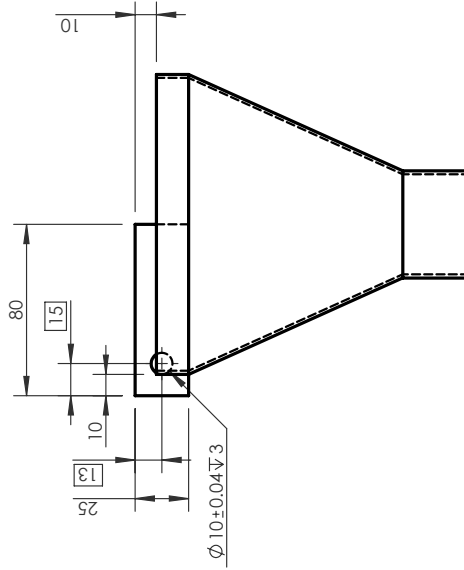
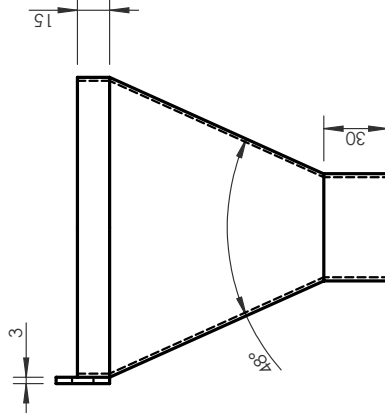
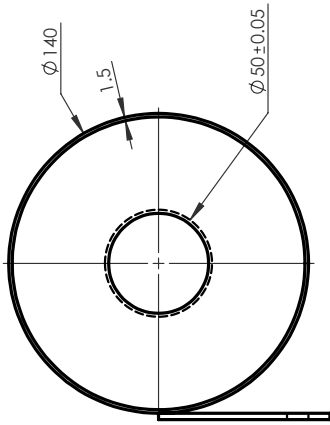

SHEET THICKNESS 1.5mm

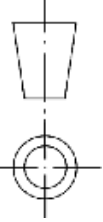
UNLESS OTHERWISE SPECIFIED: STD. TOLERANCE DIMENSIONS ARE IN MILLIMETER MILLIMETER: ±0.1, ANGULAR: ±0.05° * DOES NOT APPLY TO HOLE SIZE				BANGLADESH RICE RESEARCH INSTITUTE SFMRA PROJECT, FMPHT DIVISION		DO NOT SCALE DRAWING	
DETAILS	NAME	SIGNATURE	DATE	TITLE: BRRI COMPACT RICE MILL (BRRI RM2023)			
DRAWN	ENGR. SHAFER JAHAN RHAN	S. J.K	12-AUG-2023	FINISH: NONE		FIRST ISSUED: 02-AUG-2023	
CHK'D	DR. MD. MOSHARRAF HOSSAIN	M. M.H	18-DEC-2023	DRG. NAME: IMPURITIES DRAIN LINE			
APP'VD	DR. AKM SAIBUL ISLAM	A. S.I	30-DEC-2023	DWG NO: RM2023_s3-54			
THIRD ANGLE PROJECTION:							
NOTE: DEBURR AND BREAK SHARP EDGES ALL BENDS MIN. RADIUS UNLESS SPECIFIED				MANUFACTURING METHOD: MACHINING, BENDING & WELDING			
				MATERIAL: Plain Carbon Steel		WEIGHT: 563.31 g	
				SCALE: 1:5		REVISION: A	
				SHEET 97		A	

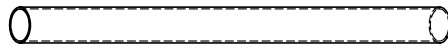

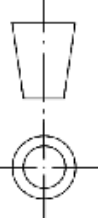

N.B: HOSE PIPE
REQUIRED INNER DIAMETER: 50mm

UNLESS OTHERWISE SPECIFIED: STD. TOLERANCE DIMENSIONS ARE IN MILLIMETER MILLIMETER: ±0.1, ANGULAR: ± 0.05° * DOES NOT APPLY TO HOLE SIZE				BANGLADESH RICE RESEARCH INSTITUTE SFMRA PROJECT, FMPHT DIVISION		DO NOT SCALE DRAWING	
DETAILS		NAME	SIGNATURE	DATE	TITLE: BRII COMPACT RICE MILL (BRII RM2023)		
DRAWN	ENGR. SHAFER JAHAN KHAN	S. J.K		12-AUG-2023	DRG. NAME: HOSE PIPE 50MM INNER DIA		
CHK'D	DR. MD. MOSHARRAF HOSSAIN	M. M.H		18-DEC-2023	DWG NO: RM2023_S3-52		
APP'VD	DR. AKKI SAIBUL ISLAM	A.S.I		30-DEC-2023	MANUFACTURING METHOD: MACHINING & WELDING		
THIRD ANGLE PROJECTION:							
				MATERIAL: Custom Plastic			
				SCALE: 1:10			
				WEIGHT: 407.60 g			
				REVISION: A			

NOTE: DEBURR AND BREAK
SHARP EDGES ALL BENDS MIN.
RADIUS UNLESS SPECIFIED

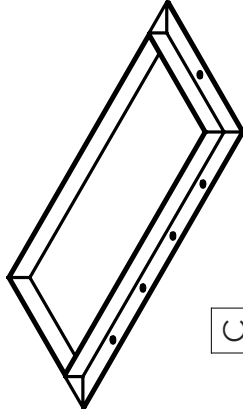
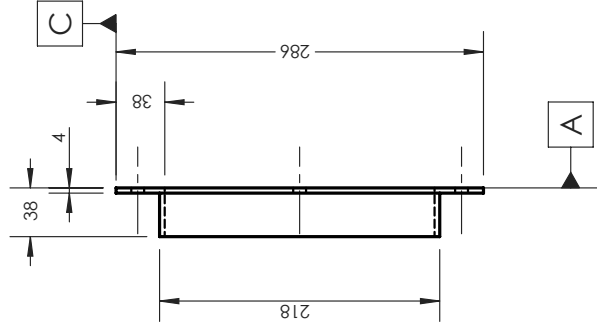
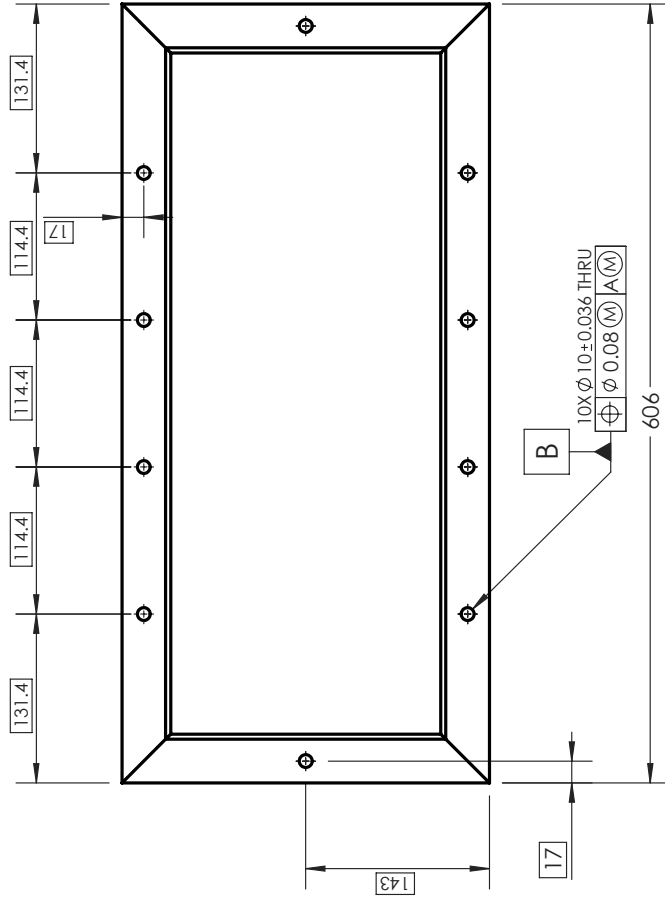
*TOTAL 10 HOLES WITH DIA. $10 \times \phi 10 \pm 0.036$ THRU mm DIA.
 *ONLY ONE SIDE SIZES HAS SHOWN HERE.
 *ANOTHER SIDE IS SYMMETRY.
 *ANGLE BAR SIZE: **38X38X4 mm**

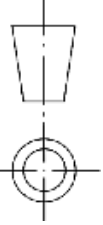

UNLESS OTHERWISE SPECIFIED: STD. TOLERANCE DIMENSIONS ARE IN MILLIMETER MILLIMETER: ±0.1, ANGULAR: ± 0.05° * DOES NOT APPLY TO HOLE SIZE				BANGLADESH RICE RESEARCH INSTITUTE SFMRA PROJECT, FMPHT DIVISION		DO NOT SCALE DRAWING	
DETAILS	NAME	SIGNATURE	DATE	FINISH: NONE			
DRAWN	ENGR. SHAFER JAHAN RHAN	S J K	17-AUG-2023	FIRST ISSUED: 02-AUG-2023			
CHK'D	DR. MD. MOSHARRAF HOSSAIN	M M H	18-DEC-2023	TITLE: BRI COMPACT RICE MILL (BRI RM2023)			
APP'VD	DR. AKM SAIFUL ISLAM	A S I	30-DEC-2023	DRG. NAME: FLANGE PART			
THIRD ANGLE PROJECTION:				DWG NO: RM2023_S4-53			
				MANUFACTURING METHOD: MACHINING, BENDING & WELDING			
NOTE: DEBURR AND BREAK SHARP EDGES ALL BENDS MIN. RADIUS UNLESS SPECIFIED				MATERIAL: ASTM A36 Steel		WEIGHT: 3519.77 g	
				SCALE: 1:6		REVISION: A	
				SHEET 99			

*SHEET THICKNESS: 1.5mm.
*BENDING RADIUS: 2mm.

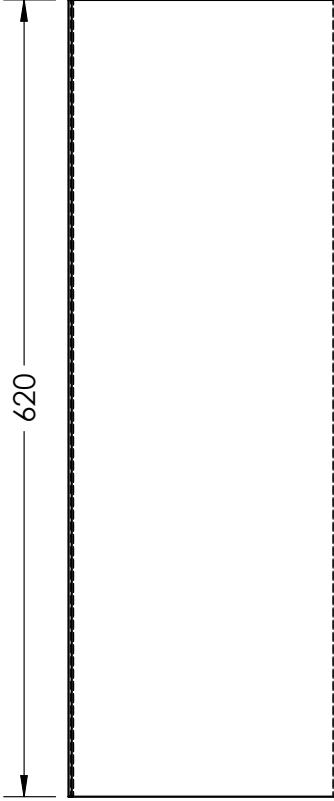
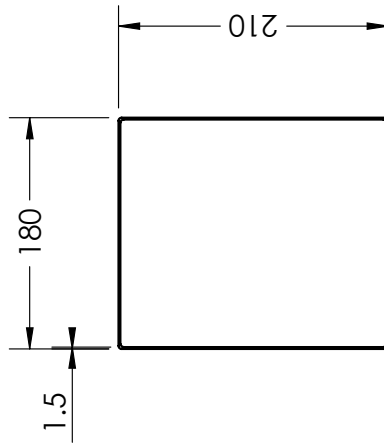
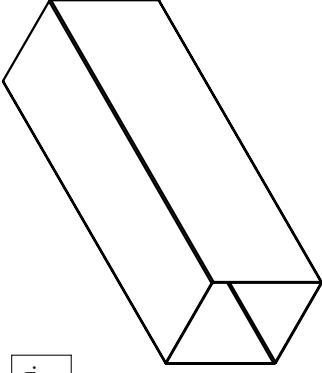

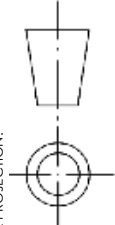
UNLESS OTHERWISE SPECIFIED: STD. TOLERANCE DIMENSIONS ARE IN MILLIMETER MILLIMETER: ±0.1, ANGULAR: ±0.05° * DOES NOT APPLY TO HOLE SIZE				BANGLADESH RICE RESEARCH INSTITUTE SFMRA PROJECT, FMPHT DIVISION		DO NOT SCALE DRAWING	
DETAILS	NAME	SIGNATURE	DATE	TITLE: BRRI COMPACT RICE MILL (BRRI RM2023)			
DRAWN	ENGR. SHAFER JAHAN RHAN	S J K	17-AUG-2023	DRG. NAME: ELEVATOR BODY - 1		FINISH: NONE	
CHK'D	DR. MD. MOSHARRAF HOSSAIN	M M H	18-DEC-2023	DWG NO: RM2023_S4-53		FIRST ISSUED: 02-AUG-2023	
APP'VD	DR. AKM SAIFUL ISLAM	A S I	30-DEC-2023	DRG. NAME: ELEVATOR BODY - 1 DWG NO: RM2023_S4-53			
THIRD ANGLE PROJECTION:							
NOTE: DEBURR AND BREAK SHARP EDGES ALL BENDS MIN. RADIUS UNLESS SPECIFIED				MANUFACTURING METHOD: MACHINING, BENDING & WELDING			
				MATERIAL: Plain Carbon Steel		WEIGHT: 5614.60 g	
				SCALE: 1:10		REVISION: A	
				SHEET 100		A	

*SHEET THICKNESS: 1.5mm.
*BENDING RADIUS: 2mm.

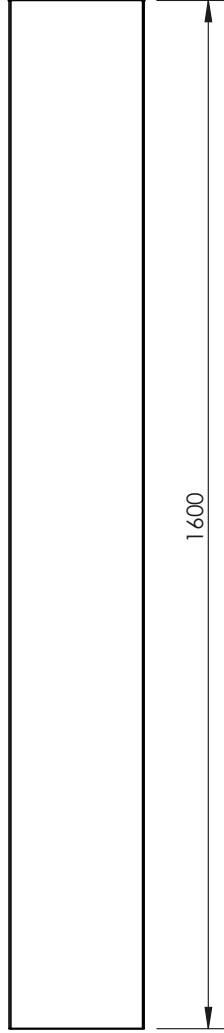
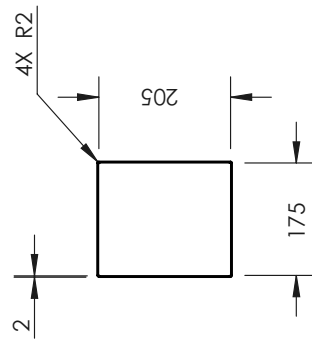
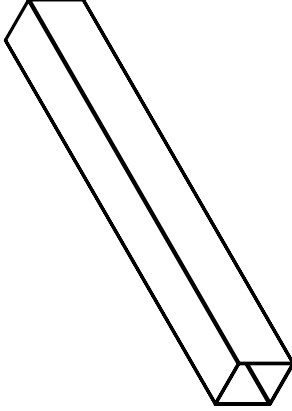

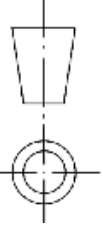

UNLESS OTHERWISE SPECIFIED: STD. TOLERANCE DIMENSIONS ARE IN MILLIMETER MILLIMETER: ±0.1, ANGULAR: ±0.05° * DOES NOT APPLY TO HOLE SIZE				BANGLADESH RICE RESEARCH INSTITUTE SFMRA PROJECT, FMPHT DIVISION		DO NOT SCALE DRAWING	
DETAILS		NAME	SIGNATURE	DATE	FINISH: NONE		
DRAWN		ENGR. SHAFER JAHAN RHAN	S J K	17-AUG-2023	FIRST ISSUED: 02-AUG-2023		
CHK'D	DR. MD. MOSHARRAF HOSSAIN	M M H		18-DEC-2023	TITLE: BRRI COMPACT RICE MILL (BRRI RM2023)		
APP'VD	DR. AKM SAIFUL ISLAM	A S I		30-DEC-2023	DRG. NAME: BD-1-BODY		
THIRD ANGLE PROJECTION:							
				DWG NO: RM2023_S4-55			
MANUFACTURING METHOD: MACHINING, BENDING & WELDING							
				MATERIAL: Plain Carbon Steel		WEIGHT: 19269.12 g	
				SCALE: 1:20		SHEET 101	
				REVISION:		A	

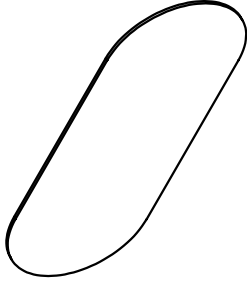
NOTE: DEBURR AND BREAK SHARP EDGES ALL BENDS MIN. RADIUS UNLESS SPECIFIED

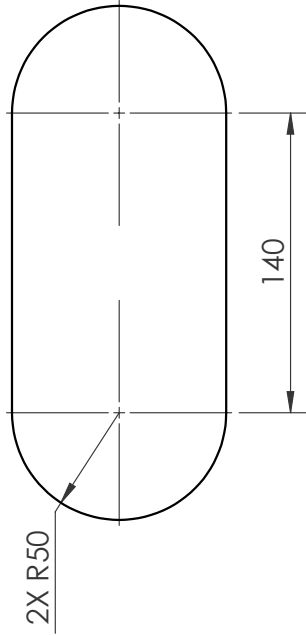
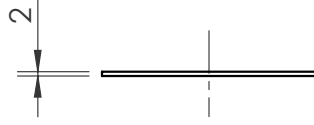

*GLASS THICKNESS: 2 mm

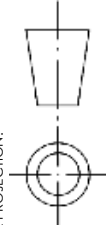

UNLESS OTHERWISE SPECIFIED: STD. TOLERANCE DIMENSIONS ARE IN MILLIMETER MILLIMETER: ±0.1, ANGULAR: ± 0.05° * DOES NOT APPLY TO HOLE SIZE				BANGLADESH RICE RESEARCH INSTITUTE SFMRA PROJECT, FMPHT DIVISION		DO NOT SCALE DRAWING	
DETAILS		NAME	SIGNATURE	DATE	TITLE: BRRI COMPACT RICE MILL (BRRI RM2023)		
DRAWN	ENGR. SHAFER JAHAN RHAN	S. J.K		17-AUG-2023	DRG. NAME: BD-2-GLASS PART		
CHK'D	DR. MD. MOSHARRAF HOSSAIN	M. M.H		18-DEC-2023	DWG NO: RM2023_s4-56		
APPVD	DR. AKM SAIBUL ISLAM	A.S.I		30-DEC-2023	MANUFACTURING METHOD: MACHINING, BENDING & WELDING		
THIRD ANGLE PROJECTION:							
NOTE: DEBURR AND BREAK SHARP EDGES ALL BENDS MIN. RADIUS UNLESS SPECIFIED				MATERIAL: Glass		WEIGHT: 107.42 g	
SCALE: 1:3				SHEET: 102		REVISION: A	

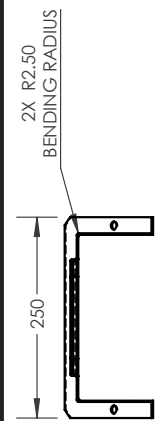

SECTION A-A

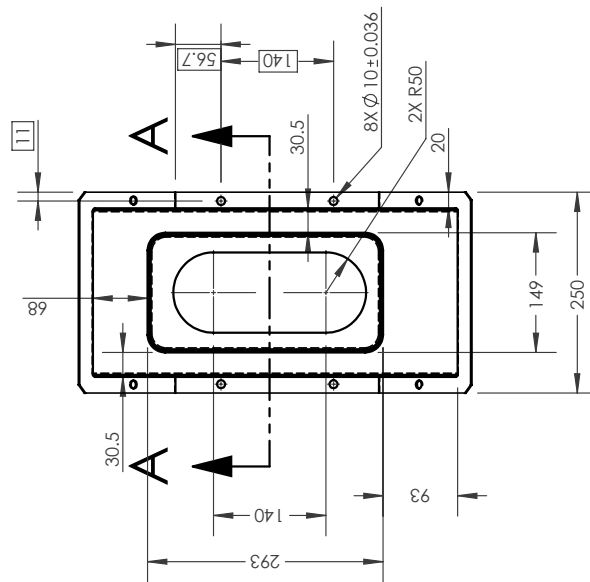

*TOTAL 8 HOLES WITH DIA. $8 \times \varnothing 10 \pm 0.036$ mm DIA.
 *ONLY ONE SIDE SIZES HAS SHOWN HERE.
 ANOTHER SIDE IS SYMMETRY.
 *SHEET THICKNESS: 2mm
 *ALL BENDING RADIUS: 2.5mm

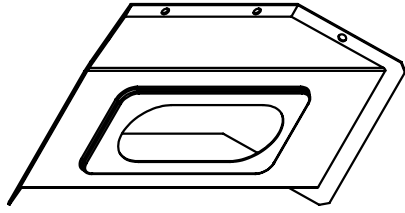
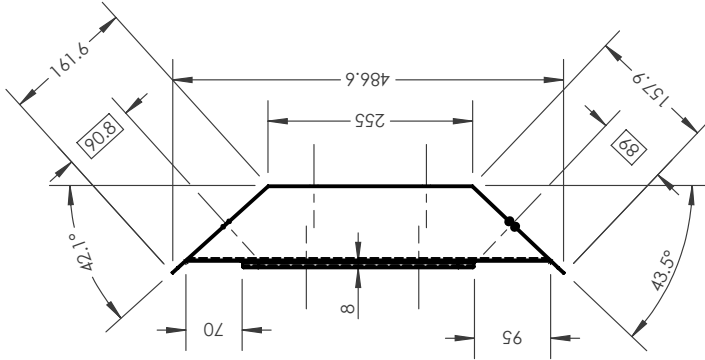

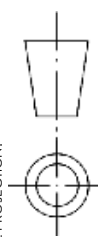
UNLESS OTHERWISE SPECIFIED: STD. TOLERANCE DIMENSIONS ARE IN MILLIMETER MILLIMETER: ± 0.1 , ANGULAR: $\pm 0.05^\circ$ * DOES NOT APPLY TO HOLE SIZE		 BANGLADESH RICE RESEARCH INSTITUTE SFMRA PROJECT, FMPHT DIVISION		DO NOT SCALE DRAWING
DETAILS		NAME	SIGNATURE	DATE
CHK'D	DR. MD. MOSHARRAF HOSSAIN	ENGR. SHAFER JAHAN RHAN	S. J.K	17-AUG-2023
APP'VD	DR. AKM SAIBUL ISLAM	M. M.H	A. S.I	18-DEC-2023
THIRD ANGLE PROJECTION:				
TITLE: BRRI COMPACT RICE MILL (BRRI RM2023)				
DRG. NAME: BD-2-DOOR				
DWG NO: RM2023_S4-57				
MANUFACTURING METHOD: MACHINING, BENDING & WELDING				
MATERIAL: ASTM A36 Steel			WEIGHT: 2698.80 g	
SCALE: 1:8			REVISION: A	
SHEET 103			A	

NOTE: DEBURR AND BREAK SHARP EDGES ALL BENDS MIN. RADIUS UNLESS SPECIFIED

*SHEET THICKNESS: 1.5mm.
*BENDING RADIUS: 2mm.

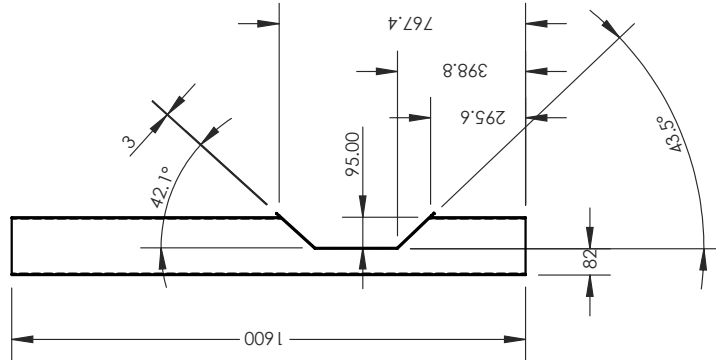
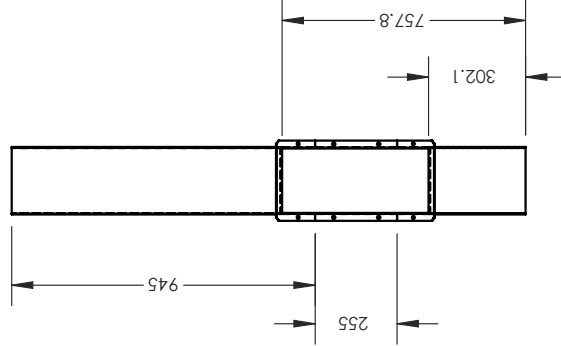
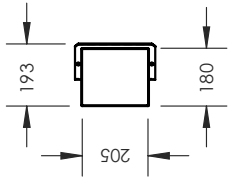

NOTE: DEBURR AND BREAK SHARP EDGES ALL BENDS MIN. RADIUS UNLESS SPECIFIED

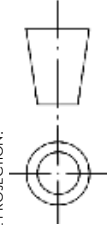

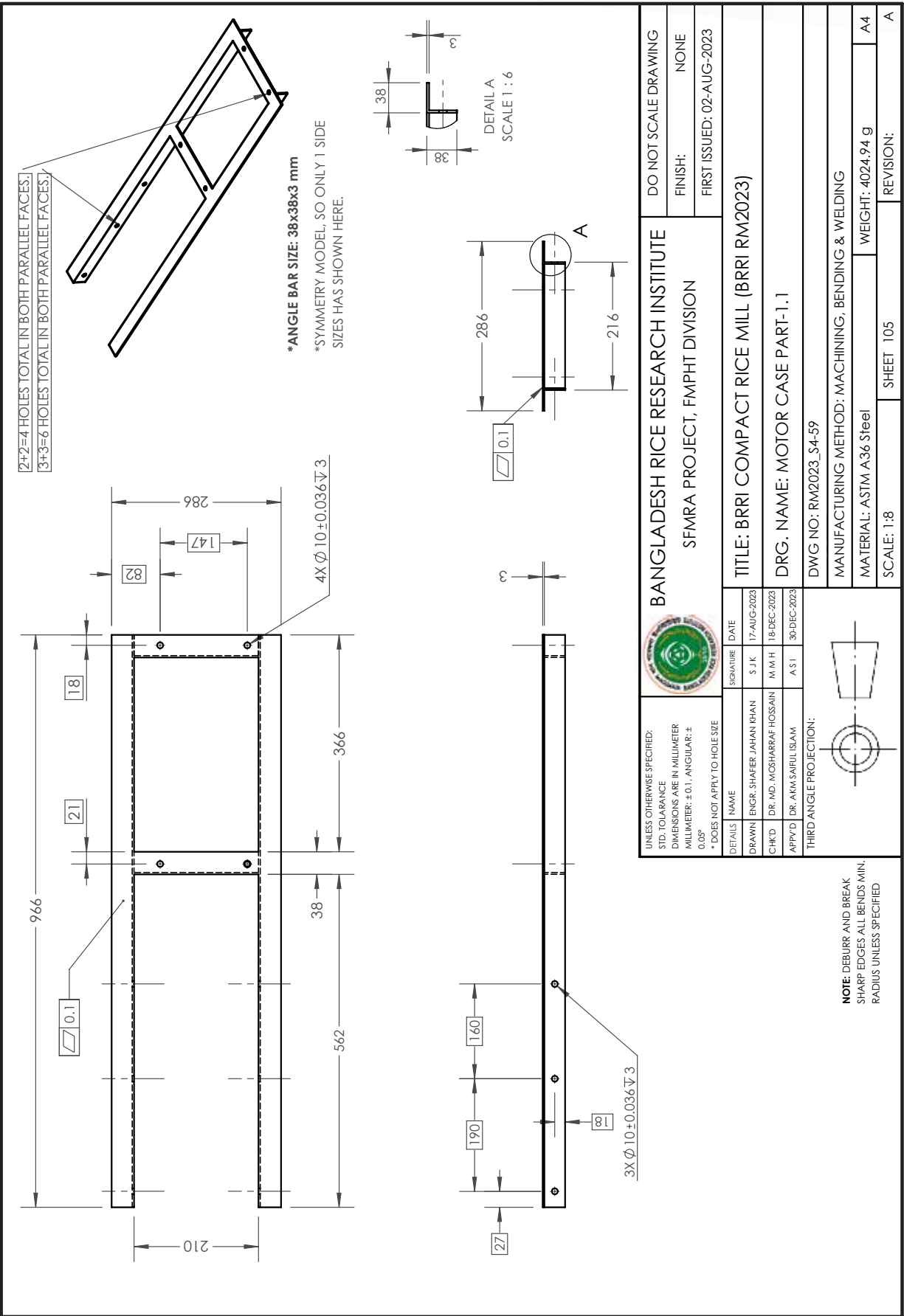
UNLESS OTHERWISE SPECIFIED: STD. TOLERANCE DIMENSIONS ARE IN MILLIMETER MILLIMETER: ±0.1, ANGULAR: ±0.05° * DOES NOT APPLY TO HOLE SIZE				BANGLADESH RICE RESEARCH INSTITUTE SFMRA PROJECT, FMPHT DIVISION		DO NOT SCALE DRAWING	
DETAILS	NAME	SIGNATURE	DATE	FINISH: NONE			
DRAWN	ENGR. SHAFER JAHAN RHAN	S J K	17-AUG-2023	FIRST ISSUED: 02-AUG-2023			
CHK'D	DR. MD. MOSHARRAF HOSSAIN	M M H	18-DEC-2023	TITLE: BRRI COMPACT RICE MILL (BRRI RM2023)			
APP'VD	DR. AKM SAIBUL ISLAM	A S I	30-DEC-2023	DRG. NAME: BD-2-BODY			
THIRD ANGLE PROJECTION:				DWG NO: RM2023_S4-58			
				MANUFACTURING METHOD: MACHINING, BENDING & WELDING			
				MATERIAL: ASTM A36 Steel		WEIGHT: 17551.64 g	
				SCALE: 1:20		REVISION: A	
				SHEET 104		A	

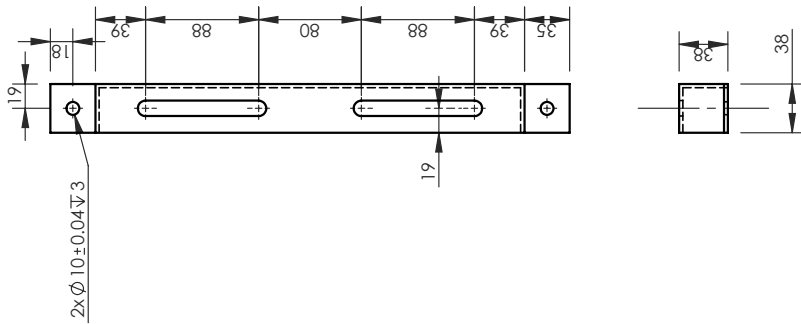

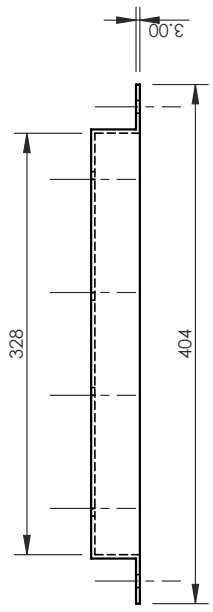
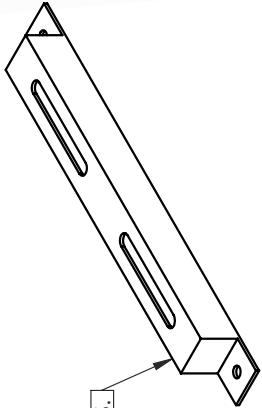

*ALL (38x38x3)mm ANGLE BARS.

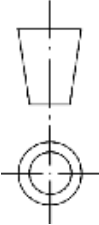

UNLESS OTHERWISE SPECIFIED: STD. TOLERANCE DIMENSIONS ARE IN MILLIMETER MILLIMETER: ±0.1, ANGULAR: ±0.05° * DOES NOT APPLY TO HOLE SIZE				BANGLADESH RICE RESEARCH INSTITUTE SFMRA PROJECT, FMPHT DIVISION		DO NOT SCALE DRAWING	
DETAILS		NAME	SIGNATURE	DATE	FINISH: NONE		
DRAWN		ENGR. SHAFER JAHAN KHAN	S. J.K	17-AUG-2023	FIRST ISSUED: 02-AUG-2023		
CHK'D	DR. MD. MOSHARRAF HOSSAIN	M. M.H		18-DEC-2023	TITLE: BRRI COMPACT RICE MILL (BRRI RM2023)		
APP'VD	DR. AKM SAIFUL ISLAM	A.S.I		30-DEC-2023	DRG. NAME: MOTOR CASE PART- 1.2		
THIRD ANGLE PROJECTION:				DWG NO: SH_1515206468_S4-60			
NOTE: DEBURR AND BREAK SHARP EDGES ALL BENDS MIN. RADIUS UNLESS SPECIFIED				MANUFACTURING METHOD: MACHINING, BENDING & WELDING			
				MATERIAL: ASTM A36		WEIGHT: 1100 g	
				SCALE: 1:3		REVISION: A	
				SHEET 106		A	

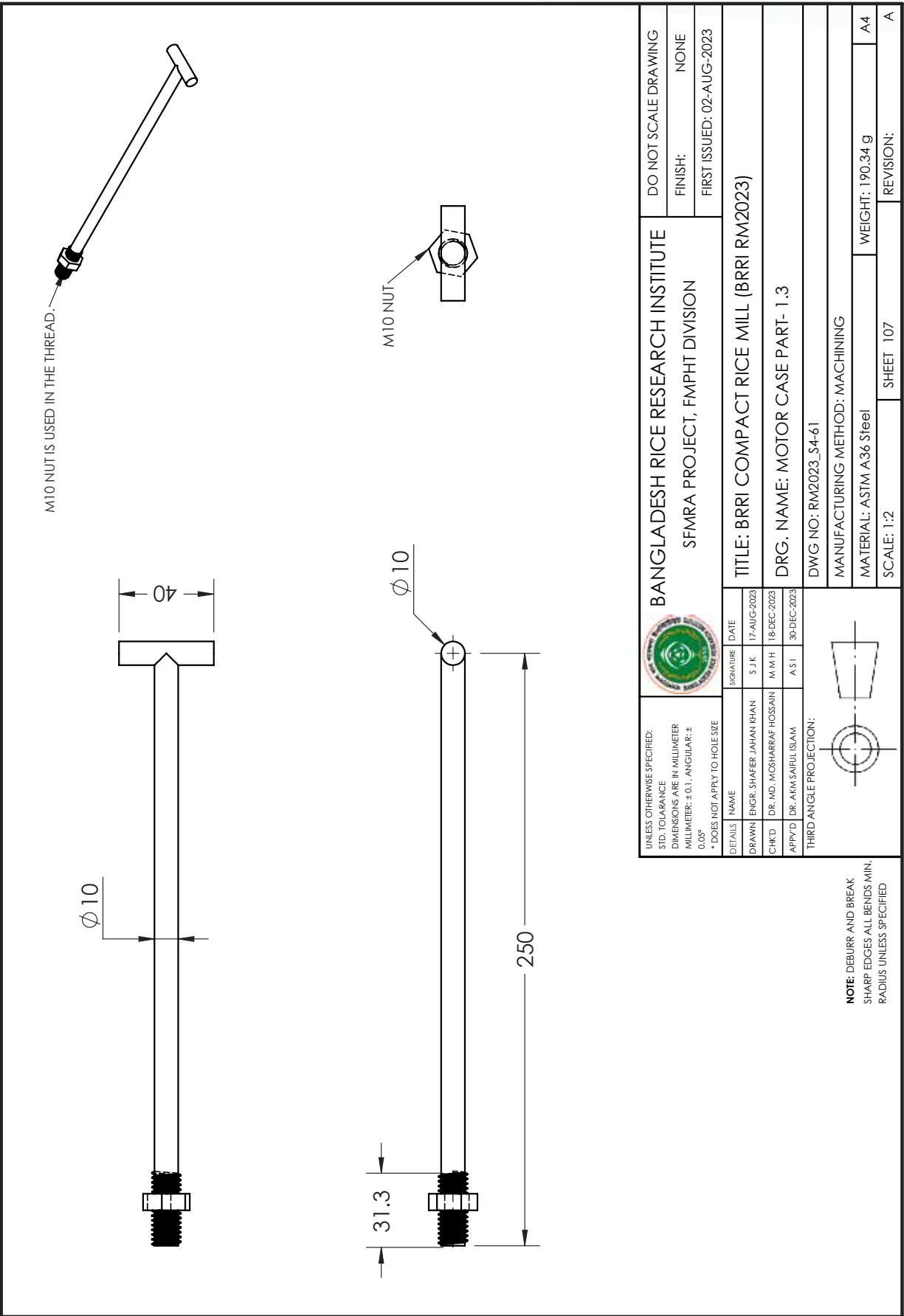

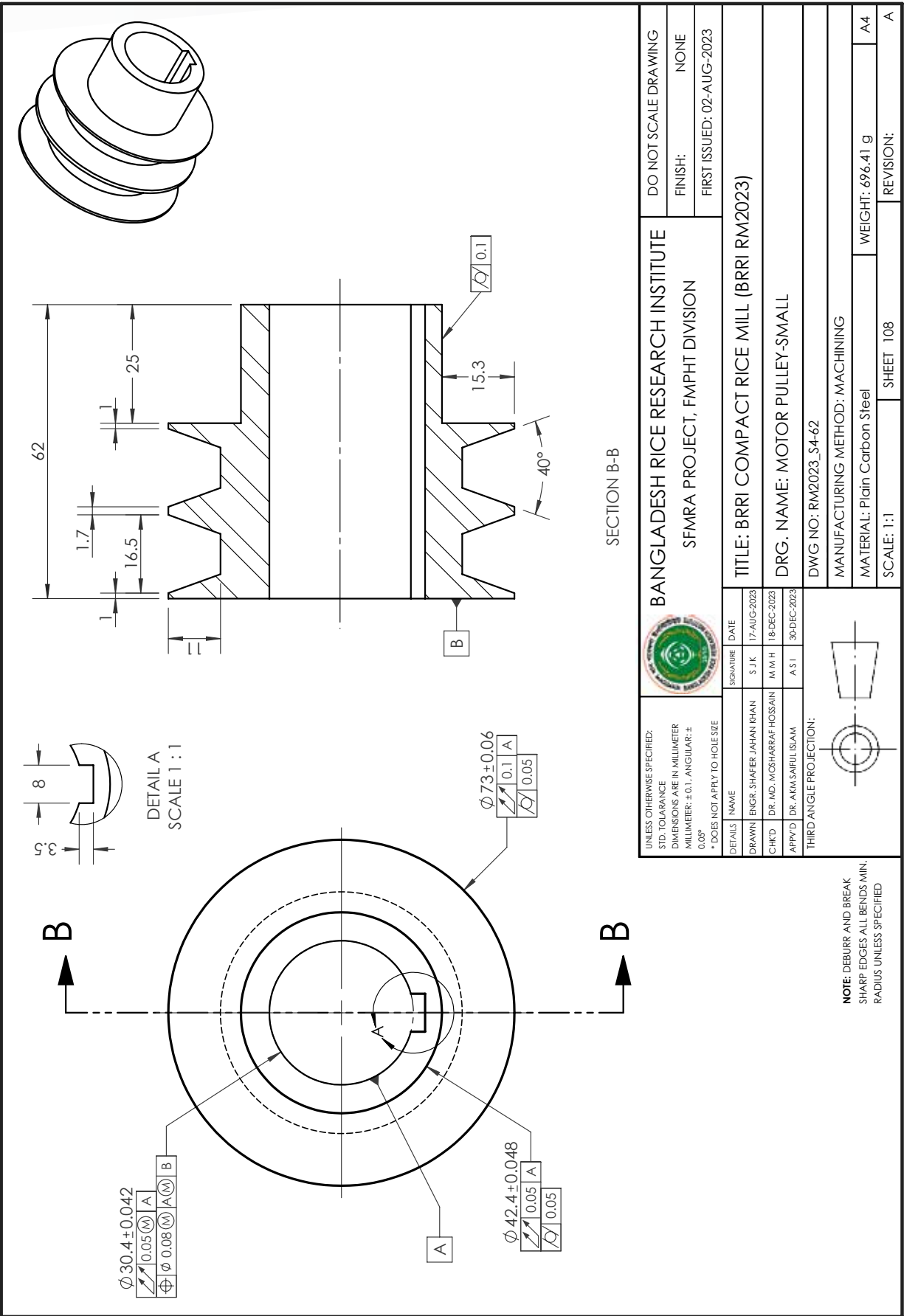

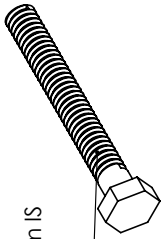

*TYPE-M10 BOLT WITH LENGTH 60mm IS USED AS PULLEY LOCK BOLT.
*THREAD M10X1.5

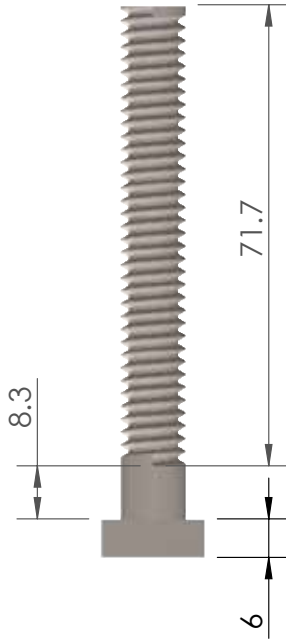
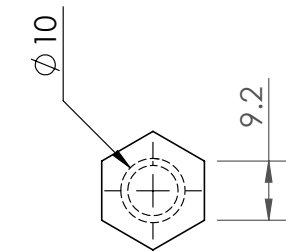

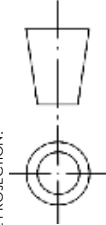
UNLESS OTHERWISE SPECIFIED: STD. TOLERANCE DIMENSIONS ARE IN MILLIMETER MILLIMETER: ±0.1, ANGULAR: ± 0.05° * DOES NOT APPLY TO HOLE SIZE				BANGLADESH RICE RESEARCH INSTITUTE SFMRA PROJECT, FMPHT DIVISION		DO NOT SCALE DRAWING	
DETAILS		NAME	SIGNATURE	DATE	FINISH: NONE		
DRAWN		ENGR. SHAFER JAHAN RHAN	S. J.K	17-AUG-2023	FIRST ISSUED: 02-AUG-2023		
CHK'D	DR. MD. MOSHARRAF HOSSAIN	M. M. H		18-DEC-2023	TITLE: BRRI COMPACT RICE MILL (BRRI RM2023)		
APP'VD	DR. AKM SAIBUL ISLAM	A. S. I		30-DEC-2023	DRG. NAME: PULLEY LOCK BOLT		
THIRD ANGLE PROJECTION:				DWG NO: RM2023_S4-63			
		MANUFACTURING METHOD: MACHINING					
NOTE: DEBURR AND BREAK SHARP EDGES ALL BENDS MIN. RADIUS UNLESS SPECIFIED		MATERIAL: Stainless Steel (ferritic)		WEIGHT: 49.87 g		REVISION: A	
SCALE: 1:1		SHEET: 109		A			

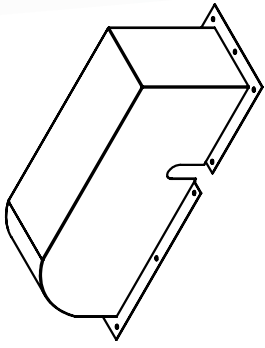

*MODEL IS SYMMETRY.
 *ONE SIDE SIZES HAS SHOWN HERE.
 *SHEET THICKNESS: 1.5mm
 *BENDING RADIUS: 2mm

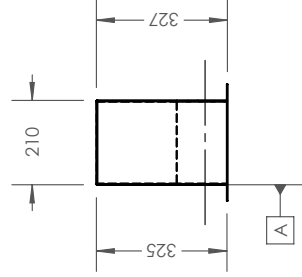
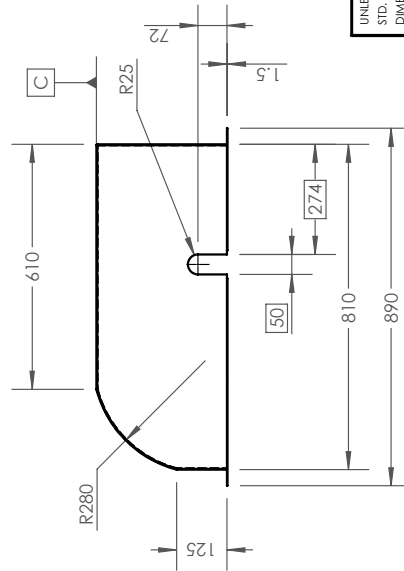
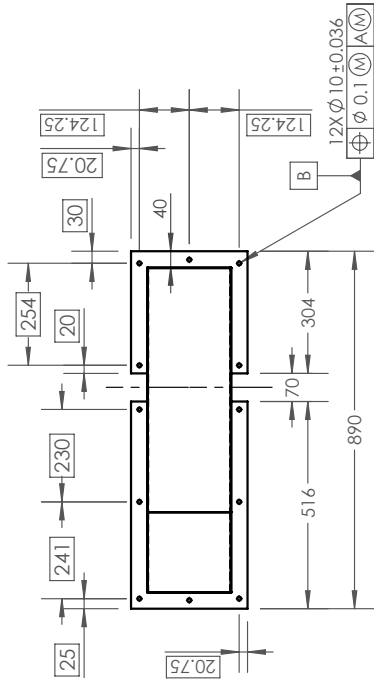

NOTE: DEBURR AND BREAK SHARP EDGES ALL BENDS MIN. RADIUS UNLESS SPECIFIED

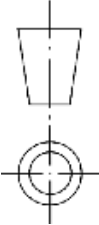
		BANGLADESH RICE RESEARCH INSTITUTE SFMRA PROJECT, FMPHT DIVISION		DO NOT SCALE DRAWING
UNLESS OTHERWISE SPECIFIED: STD. TOLERANCE DIMENSIONS ARE IN MILLIMETER MILLIMETER: ±0.1, ANGULAR: ±0.05° * DOES NOT APPLY TO HOLE SIZE		SIGNATURE S. J.K.	DATE 17-AUG-2023	FINISH: NONE
DRAWN ENGR. SHAFER JAHAN KHAN	M. M. H.	18-DEC-2023	FIRST ISSUED: 02-AUG-2023	
CHK'D DR. MD. MOSHARRAF HOSSAIN	A. S. I.	30-DEC-2023	TITLE: BRRI COMPACT RICE MILL (BRRI RM2023)	
APP'VD DR. AKM SAIBUL ISLAM		DRG. NAME: TOP COVER		
THIRD ANGLE PROJECTION: 		DWG NO: RM2023_S4-64		
MANUFACTURING METHOD: MACHINING, BENDING & WELDING		MATERIAL: Plain Carbon Steel		
SCALE: 1:16		SHEET 110		REVISION: A
WEIGHT: 10017.98 g		A4		

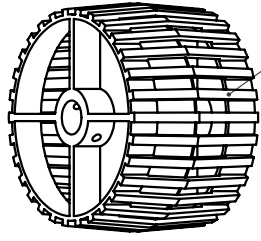

NUMBER OF RIB: 30
*ELEVATOR TOP PULLEY.

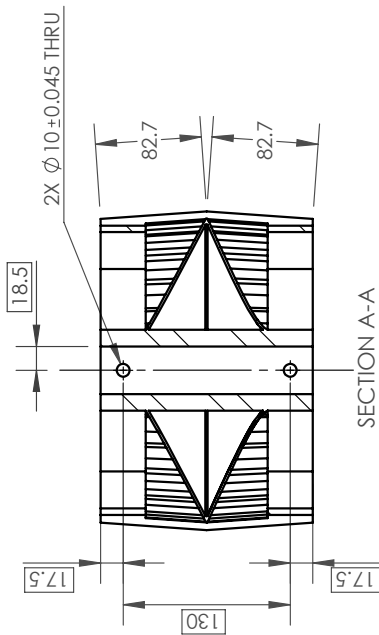
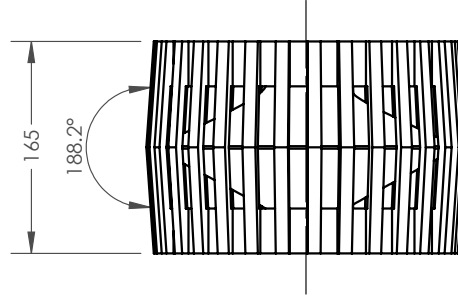

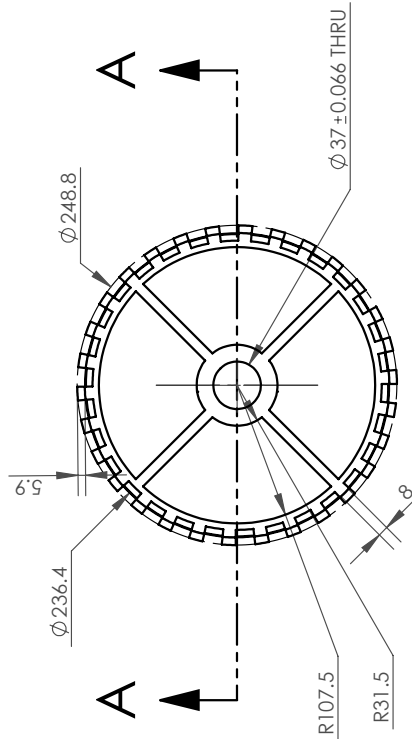

SECTION A-A

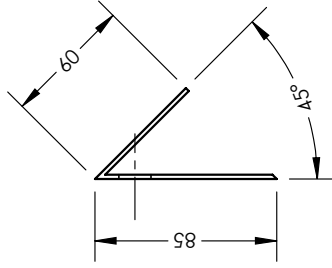
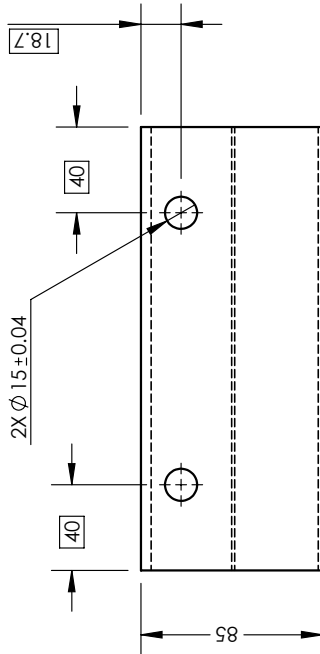
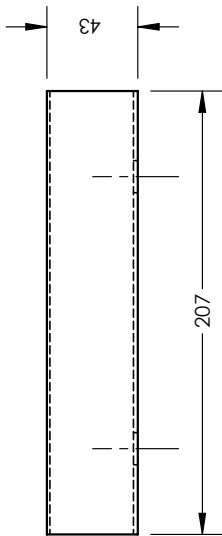
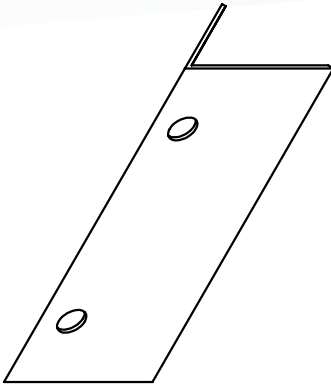

		BANGLADESH RICE RESEARCH INSTITUTE SFMRA PROJECT, FMPHT DIVISION		DO NOT SCALE DRAWING
UNLESS OTHERWISE SPECIFIED: STD. TOLERANCE DIMENSIONS ARE IN MILLIMETER MILLIMETER: ±0.1, ANGULAR: ± 0.05° * DOES NOT APPLY TO HOLE SIZE		SIGNATURE S. J.K.	DATE 17-AUG-2023	FINISH: NONE
DRAWN ENGR. SHAFER JAHAN KHAN	CHECKED DR. MD. MOSHARRAF HOSSAIN	APPROVED DR. AKM SAIBUL ISLAM	DATE 18-DEC-2023 30-DEC-2023	FIRST ISSUED: 02-AUG-2023
TITLE: BRRI COMPACT RICE MILL (BRRI RM2023)				
DRG. NAME: FLAT BELT PULLEY				
DWG NO: RM2023_S4-65				
MANUFACTURING METHOD: MACHINING, BENDING & WELDING				
MATERIAL: ASTM A36 Steel			WEIGHT: 9884.28 g	A4
SCALE: 1:5			SHEET 111	REVISION: A

NOTE: DEBURR AND BREAK SHARP EDGES ALL BENDS MIN. RADIUS UNLESS SPECIFIED



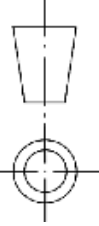

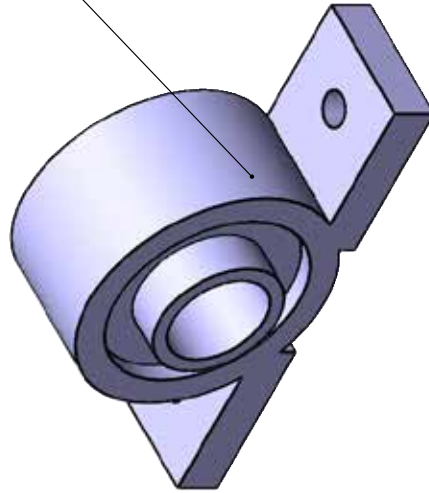
UNLESS OTHERWISE SPECIFIED: STD. TOLERANCE DIMENSIONS ARE IN MILLIMETER MILLIMETER: ±0.1, ANGULAR: ± 0.05° * DOES NOT APPLY TO HOLE SIZE				BANGLADESH RICE RESEARCH INSTITUTE SFMRA PROJECT, FMPHT DIVISION		DO NOT SCALE DRAWING FINISH: NONE FIRST ISSUED: 02-AUG-2023	
DETAILS	NAME	SIGNATURE	DATE	TITLE: BRRI COMPACT RICE MILL (BRRI RM2023)			
DRAWN	ENGR. SHAFER JAHAN RHAN	S. J.K	17-AUG-2023	DRG. NAME: TOP CONTROL PART - 1			
CHK'D	DR. MD. MOSHARRAF HOSSAIN	M. M.H	18-DEC-2023	DWG NO: RM2023_S4-66			
APP'VD	DR. AKM SAIBUL ISLAM	A.S.I	30-DEC-2023	MANUFACTURING METHOD: MACHINING, BENDING & WELDING			
THIRD ANGLE PROJECTION:							
NOTE: DEBURR AND BREAK SHARP EDGES ALL BENDS MIN. RADIUS UNLESS SPECIFIED				MATERIAL: ASTM A36 Steel SCALE: 1:3 WEIGHT: 446.27 g			
				SHEET 112		REVISION: A	



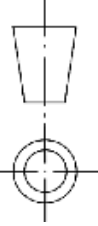

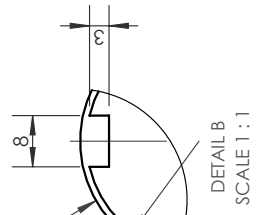
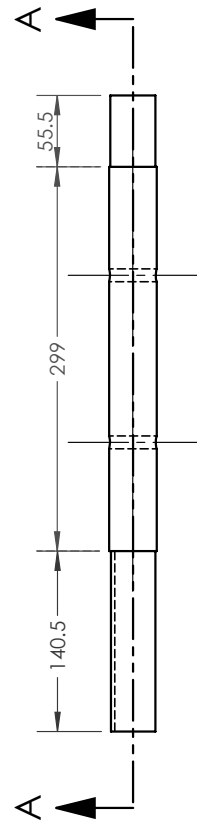
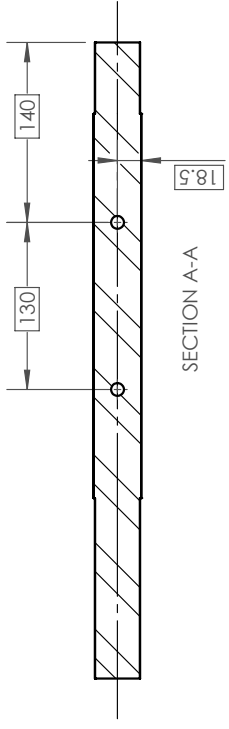
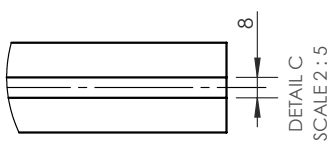
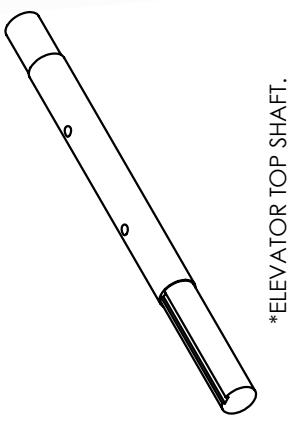
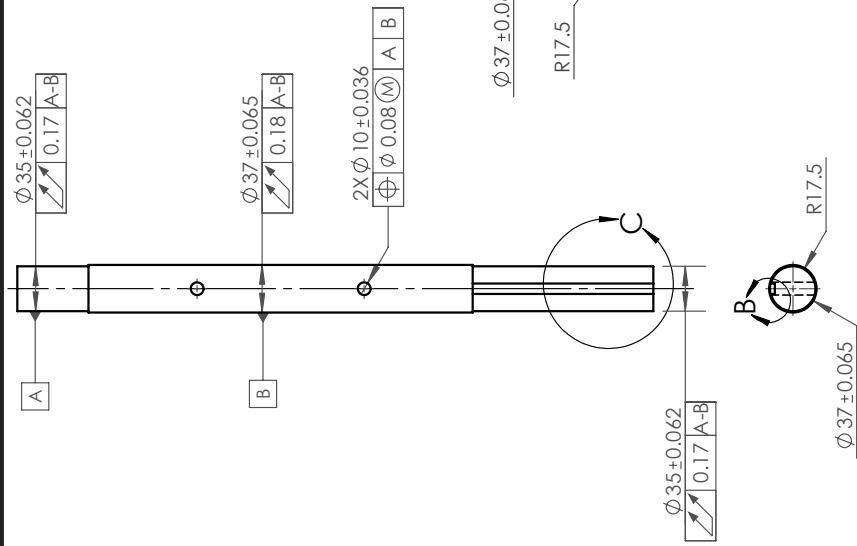
BEARING BLOCK
 MODEL: UCP207-ISB
 INNER DIA 35mm
 *NEED 2 BEARING BLOCK FOR BOTH SIDE
 IN HE ELEVATOR TOP SIDE.

UNLESS OTHERWISE SPECIFIED: STD. TOLERANCE DIMENSIONS ARE IN MILLIMETER MILLIMETER: ±0.1, ANGULAR: ± 0.05° * DOES NOT APPLY TO HOLE SIZE				BANGLADESH RICE RESEARCH INSTITUTE SFMRA PROJECT, FMPHT DIVISION		DO NOT SCALE DRAWING	
DETAILS		NAME	SIGNATURE	DATE	TITLE: BRRI COMPACT RICE MILL (BRRI RM2023)		
DRAWN		ENGR. SHAFER JAHAN KHAN	S. J.K	17-AUG-2023	DRG. NAME: UCP207 - ISB		
CHK'D		DR. MD. MOSHARRAF HOSSAIN	M. M.H	18-DEC-2023	DWG NO: RM2023_s4-67		
APP'D		DR. AKM SAIBUL ISLAM	A.S.I	30-DEC-2023	MANUFACTURING METHOD: MACHINING, BENDING & WELDING		
THIRD ANGLE PROJECTION:				MATERIAL: Gray Cast Iron			
NOTE: DEBURR AND BREAK SHARP EDGES ALL BENDS MIN. RADIUS UNLESS SPECIFIED		SCALE: 1:2		SHEET 113		REVISION: A	
		WEIGHT: 2223.51 g		A4			

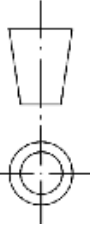

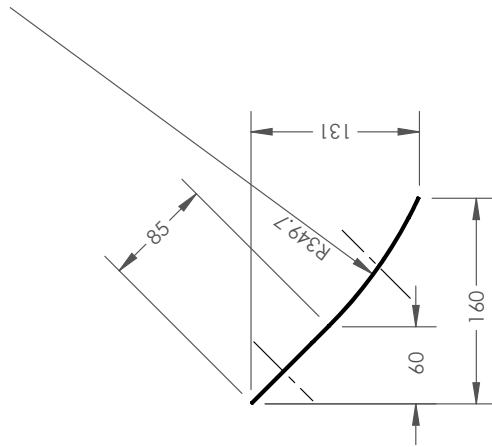
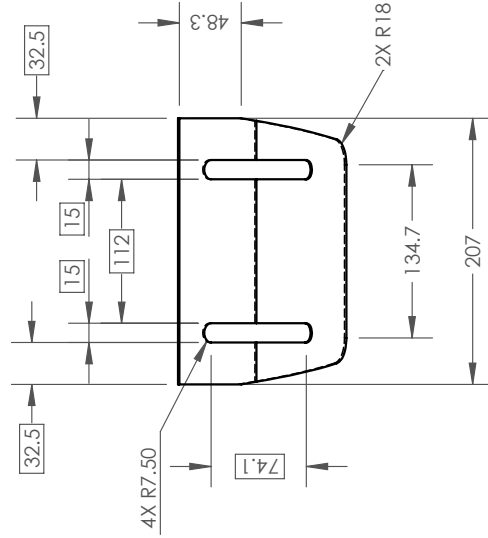
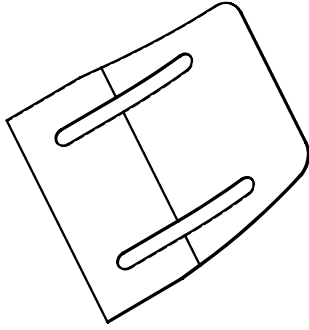
UNLESS OTHERWISE SPECIFIED: STD. TOLERANCE DIMENSIONS ARE IN MILLIMETER MILLIMETER: ±0.1, ANGULAR: ±0.05° * DOES NOT APPLY TO HOLE SIZE				BANGLADESH RICE RESEARCH INSTITUTE SFMRA PROJECT, FMPHT DIVISION		DO NOT SCALE DRAWING
DETAILS	NAME	SIGNATURE	DATE	TITLE: BRRI COMPACT RICE MILL (BRRI RM2023) DRG. NAME: PULLEY SHAFT-TOP DWG NO: RM2023_s4-68		FINISH: NONE
DRAWN	ENGR. SHAFER JAHAN KHAN	S J K	17-AUG-2023	DRG. NAME: PULLEY SHAFT-TOP DWG NO: RM2023_s4-68		FIRST ISSUED: 02-AUG-2023
CHK'D	DR. MD. MOSHARRAF HOSSAIN	M M H	18-DEC-2023	MANUFACTURING METHOD: MACHINING, BENDING & WELDING MATERIAL: ASTM A36 Steel SCALE: 1:5		
APP'VD	DR. AKM SAIBUL ISLAM	A S I	30-DEC-2023	THIRD ANGLE PROJECTION: 		
NOTE: DEBURR AND BREAK SHARP EDGES ALL BENDS MIN. RADIUS UNLESS SPECIFIED			SHEET 114		REVISION: A	
			WEIGHT: 3929.27 g		A4	



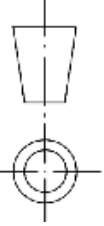

UNLESS OTHERWISE SPECIFIED: STD. TOLERANCE DIMENSIONS ARE IN MILLIMETER MILLIMEER: ±0.1, ANGULAR: ± 0.05° * DOES NOT APPLY TO HOLE SIZE				BANGLADESH RICE RESEARCH INSTITUTE SFMRA PROJECT, FMPHT DIVISION		DO NOT SCALE DRAWING	
DETAILS		NAME	SIGNATURE	DATE	FINISH: NONE		
CHK'D	DR. MD. MOSHARRAF HOSSAIN	ENGR. SHAFER JAHAN RHAN	S. J.K	17-AUG-2023	FIRST ISSUED: 02-AUG-2023		
APP'VD	DR. AKM SAIBUL ISLAM	M. M. H	A. S. I	18-DEC-2023	TITLE: BRRI COMPACT RICE MILL (BRRI RM2023)		
THIRD ANGLE PROJECTION:				DRG. NAME: TOP CONTROL PART - 2			
		DWG NO: RM2023_S4-69					
MANUFACTURING METHOD: MACHINING, BENDING & WELDING							
MATERIAL: ASTM A36 Steel				WEIGHT: 430.85 g			
SCALE: 1:5				SHEET 115		REVISION: A	

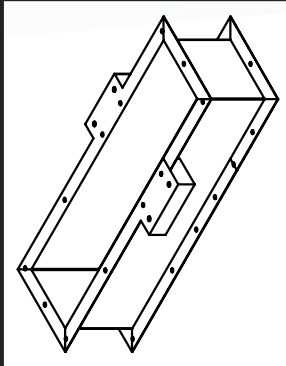
NOTE: DEBURR AND BREAK SHARP EDGES ALL BENDS MIN. RADIUS UNLESS SPECIFIED

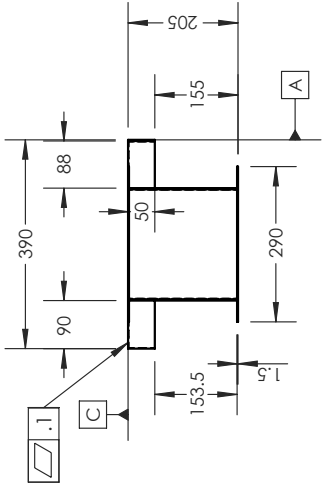
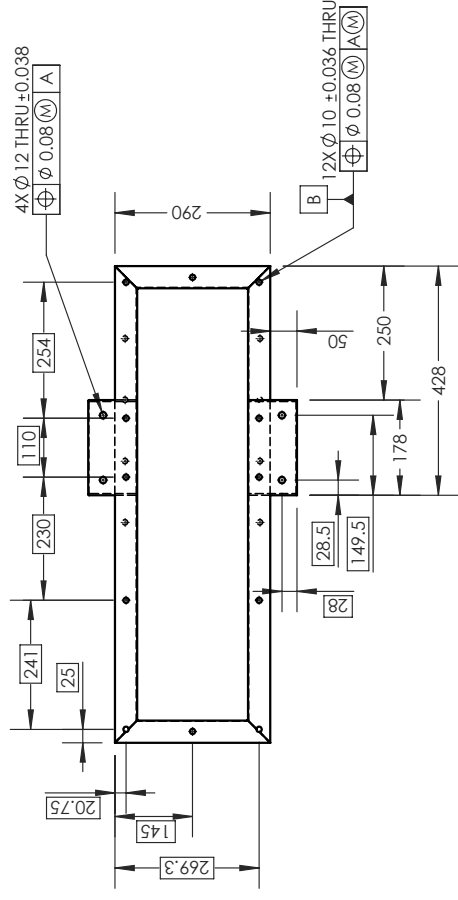

*HOLE CUTOUTS ARE SAME SIZES FOR UPPER AND BOTTOM FACE.
 **MODEL IS SYMMETRY FOR HOLES.
 **ONLY ONE SIDE SIZES HAS SHOWN HERE.
 *SHEET THICKNESS: 1.5mm
 *ALL BENDING RADIUS: 2mm

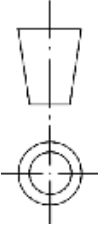

UNLESS OTHERWISE SPECIFIED: STD. TOLERANCE DIMENSIONS ARE IN MILLIMETER MILLIMETER: ±0.1, ANGULAR: ±0.05° * DOES NOT APPLY TO HOLE SIZE				BANGLADESH RICE RESEARCH INSTITUTE SFMRA PROJECT, FMPHT DIVISION		DO NOT SCALE DRAWING	
DETAILS	NAME	SIGNATURE	DATE	TITLE: BRRI COMPACT RICE MILL (BRRI RM2023)		FINISH: NONE	
DRAWN	ENGR. SHAFER JAHAN KHAN	S. J.K	17-AUG-2023	DRG. NAME: TOP PULLEY HOLDING PART		FIRST ISSUED: 02-AUG-2023	
CHK'D	DR. MD. MOSHARRAF HOSSAIN	M. M.H	18-DEC-2023	DWG NO: RM2023_s4-70		MANUFACTURING METHOD: MACHINING, BENDING & WELDING	
APP'VD	DR. AKM SAIBUL ISLAM	A. S.I	30-DEC-2023	MATERIAL: Plain Carbon Steel		WEIGHT: 7720.65 g	
THIRD ANGLE PROJECTION:						SCALE: 1:12	
NOTE: DEBURR AND BREAK SHARP EDGES ALL BENDS MIN. RADIUS UNLESS SPECIFIED				SHEET 116		REVISION: A	
				A4		A	

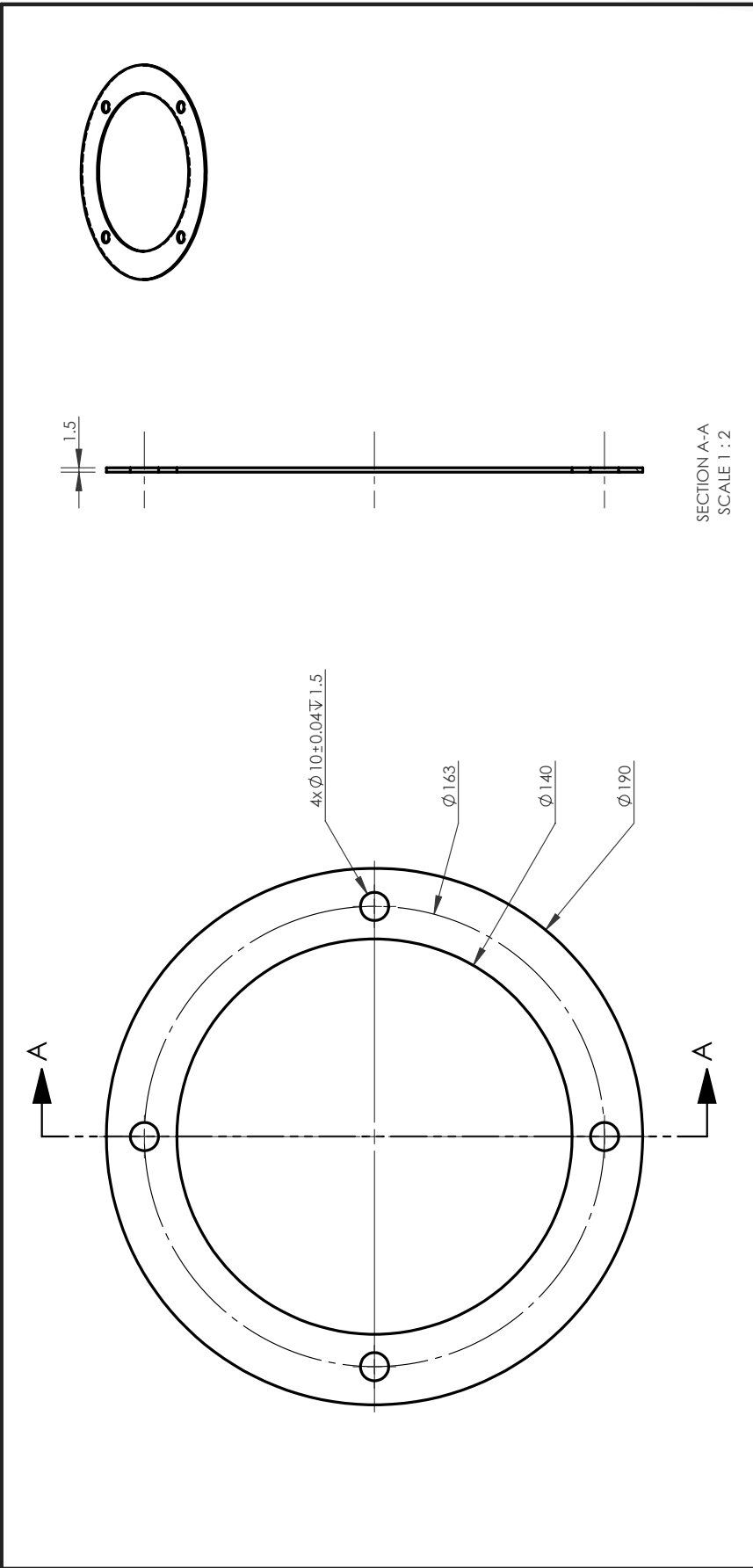

SECTION A-A
SCALE 1 : 2

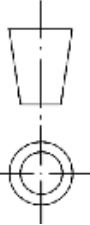
		BANGLADESH RICE RESEARCH INSTITUTE SFMRA PROJECT, FMPHT DIVISION		DO NOT SCALE DRAWING
UNLESS OTHERWISE SPECIFIED: STD. TOLERANCE DIMENSIONS ARE IN MILLIMETER MILLIMETER: ±0.1, ANGULAR: ±0.05° * DOES NOT APPLY TO HOLE SIZE		TITLE: BRRI COMPACT RICE MILL (BRRI RM2023) DRG. NAME: PADDY CONVEYER PIPE PART-1 DWG NO: RM2023_s4-71 MANUFACTURING METHOD: MACHINING, BENDING & WELDING MATERIAL: ASTM A36 Steel SCALE: 1:5	FINISH: NONE FIRST ISSUED: 02-AUG-2023	WEIGHT: 148.89 g REVISION: A
DETAILS NAME DRAWN CHK'D APP'D	SIGNATURE S J K M M H A S I	DATE 17-AUG-2023 18-DEC-2023 30-DEC-2023	THIRD ANGLE PROJECTION: 	SHEET 117

NOTE: DEBURR AND BREAK SHARP EDGES ALL BENDS MIN. RADIUS UNLESS SPECIFIED

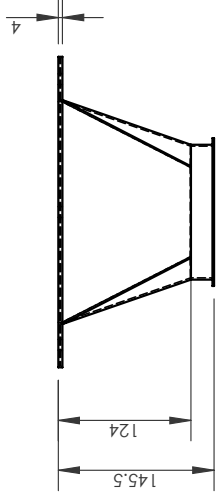
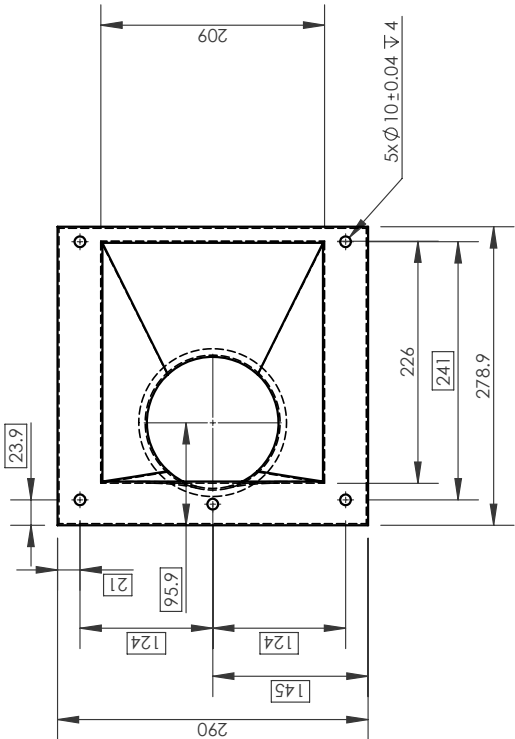
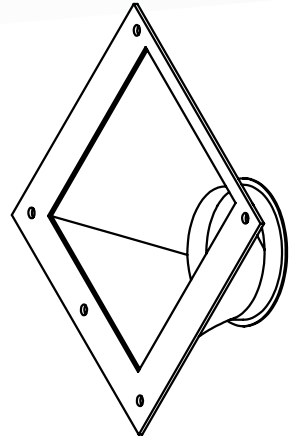
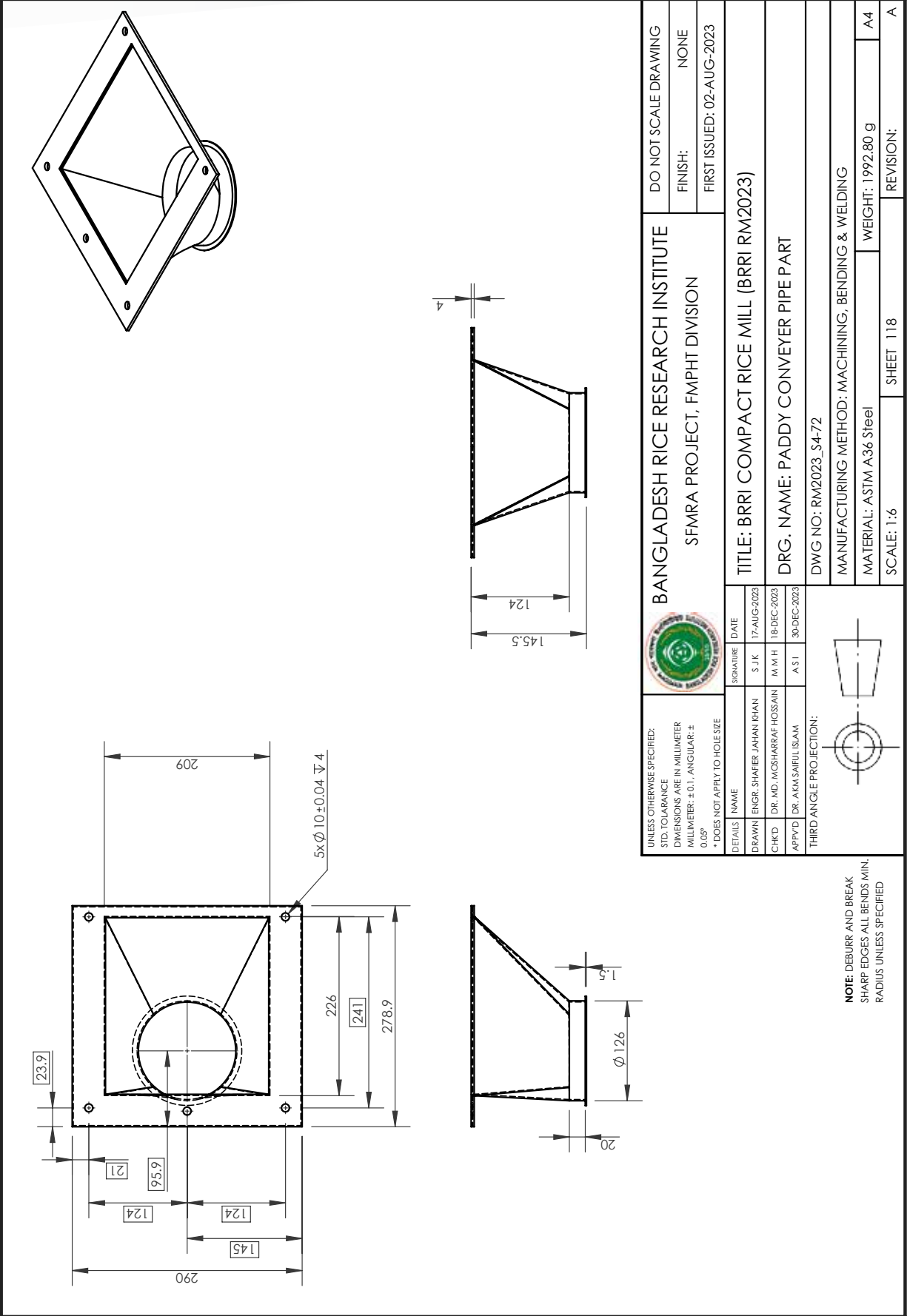

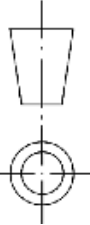
UNLESS OTHERWISE SPECIFIED: STD. TOLERANCE DIMENSIONS ARE IN MILLIMETER MILLIMETER: ±0.1, ANGULAR: ±0.05° * DOES NOT APPLY TO HOLE SIZE				BANGLADESH RICE RESEARCH INSTITUTE SFMRA PROJECT, FMPHT DIVISION		DO NOT SCALE DRAWING	
DETAILS		NAME	SIGNATURE	DATE	FINISH: NONE		
DRAWN		ENGR. SHAFER JAHAN RHAN	S. J.K	17-AUG-2023	FIRST ISSUED: 02-AUG-2023		
CHK'D		DR. MD. MOSHARRAF HOSSAIN	M. M.H	18-DEC-2023	TITLE: BRI COMPACT RICE MILL (BRI RM2023)		
APP'VD		DR. AKM SAIBUL ISLAM	A.S.I	30-DEC-2023	DRG. NAME: PADDY CONVEYER PIPE PART		
THIRD ANGLE PROJECTION:				DWG NO: RM2023_s4-72			
NOTE: DEBURR AND BREAK SHARP EDGES ALL BENDS MIN. RADIUS UNLESS SPECIFIED				MANUFACTURING METHOD: MACHINING, BENDING & WELDING			
				MATERIAL: ASTM A36 Steel		WEIGHT: 1992.80 g	
				SCALE: 1:6		REVISION: A	
				SHEET 118		A	

Power: 5.5 KW
 Horsepower: 3 HP
 Speed: 1450 rpm
 Mounting Type: Foot
 Frequency: 50 Hz
 Material: Cast Iron

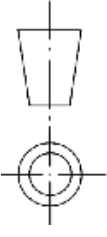

UNLESS OTHERWISE SPECIFIED: STD. TOLERANCE DIMENSIONS ARE IN MILLIMETER MILLIMETER: ±0.1, ANGULAR: ± 0.05° * DOES NOT APPLY TO HOLE SIZE				BANGLADESH RICE RESEARCH INSTITUTE SFMRA PROJECT, FMPHT DIVISION		DO NOT SCALE DRAWING	
DETAILS		NAME	SIGNATURE	DATE	FINISH: NONE		
DRAWN		ENGR. SHAFER JAHAN RHAN	S J K	17-AUG-2023	FIRST ISSUED: 02-AUG-2023		
CHK'D	DR. MD. MOSHARRAF HOSSAIN	M M H		18-DEC-2023	TITLE: BRRI COMPACT RICE MILL (BRRI RM2023)		
APP'D	DR. AKM SAIBUL ISLAM	A S I		30-DEC-2023	DRG. NAME: ELEVATOR MOTOR 3 HP		
THIRD ANGLE PROJECTION:				DWG NO: RM2023_s4-73			
NOTE: DEBURR AND BREAK SHARP EDGES ALL BENDS MIN. RADIUS UNLESS SPECIFIED				MANUFACTURING METHOD: MACHINING, BENDING & WELDING			
				MATERIAL: Gray Cast Iron		WEIGHT: 58059.80 g	
				SCALE: 1:4		REVISION: A	
				SHEET 119		A	

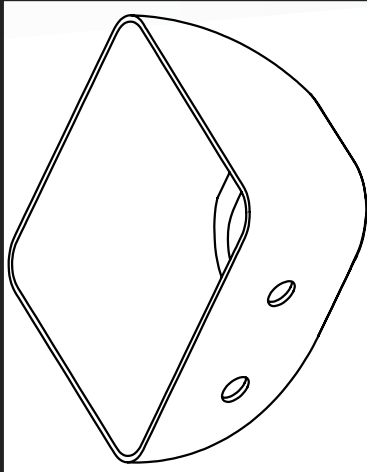

*THICKNESS: 1.5mm.
 *BUCKET TO BUCKET DISTANCE: 100mm.
 *TOTAL 53 BUCKETS WILL BE PLACED IN THE FLAT BELT.

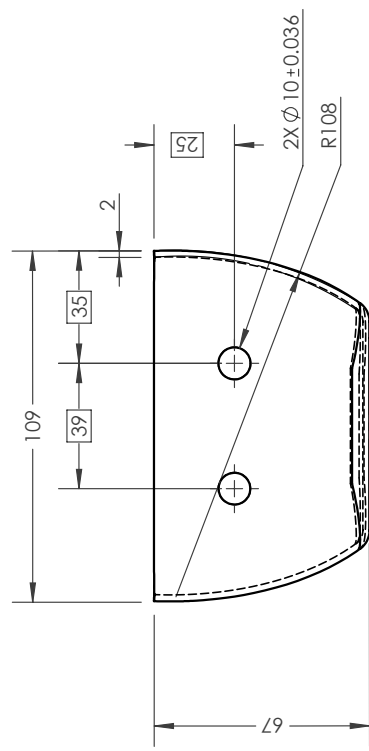
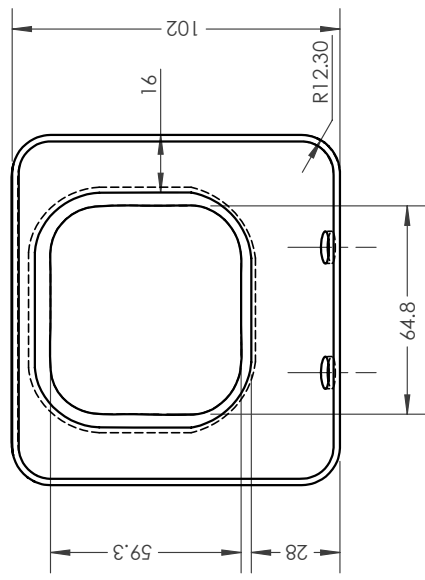

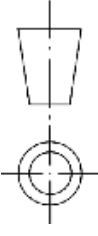
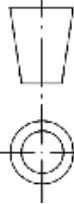
UNLESS OTHERWISE SPECIFIED: STD. TOLERANCE DIMENSIONS ARE IN MILLIMETER MILLIMETER: ±0.1, ANGULAR: ± 0.05° * DOES NOT APPLY TO HOLE SIZE				BANGLADESH RICE RESEARCH INSTITUTE SFMRA PROJECT, FMPHT DIVISION		DO NOT SCALE DRAWING
DETAILS		NAME	SIGNATURE	DATE	FINISH:	NONE
DRAWN	ENGR. SHAFER JAHAN KHAN	S J K	17-AUG-2023		FIRST ISSUED:	02-AUG-2023
CHK'D	DR. MD. MOSHARRAF HOSSAIN	M M H	18-DEC-2023		TITLE: BRRI COMPACT RICE MILL (BRRI RM2023)	
APP'VD	DR. AKM SAIBUL ISLAM	A S I	30-DEC-2023		DRG. NAME: ELEVATOR BUCKET	
THIRD ANGLE PROJECTION:				DWG NO: RM2023_s4-74		
NOTE: DEBURR AND BREAK SHARP EDGES ALL BENDS MIN. RADIUS UNLESS SPECIFIED				MANUFACTURING METHOD: MACHINING, BENDING & WELDING		
		MATERIAL: Plain Carbon Steel		WEIGHT: 445.74 g		A4
		SCALE: 1:2		SHEET: 120		REVISION: A

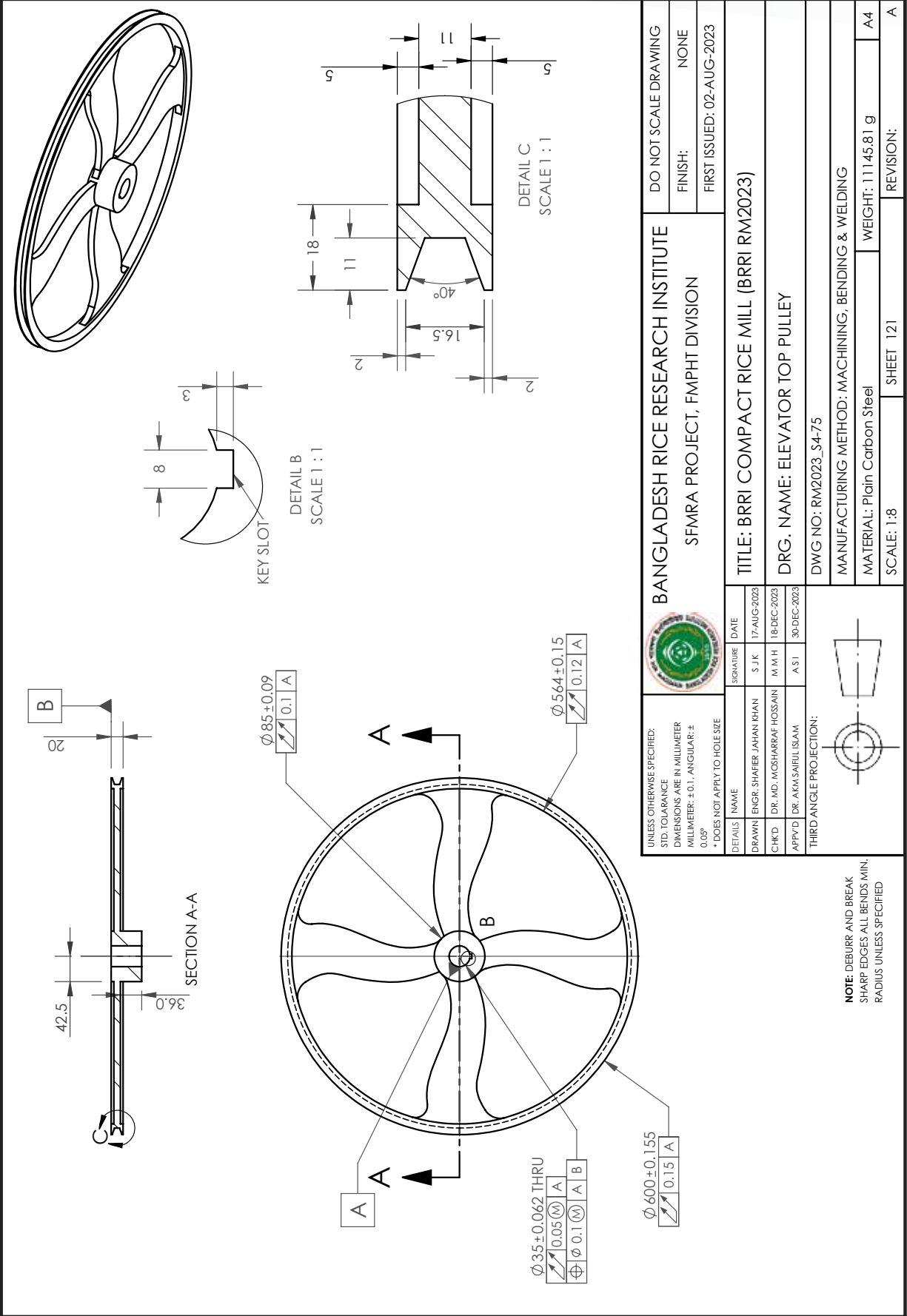

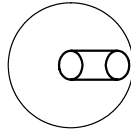
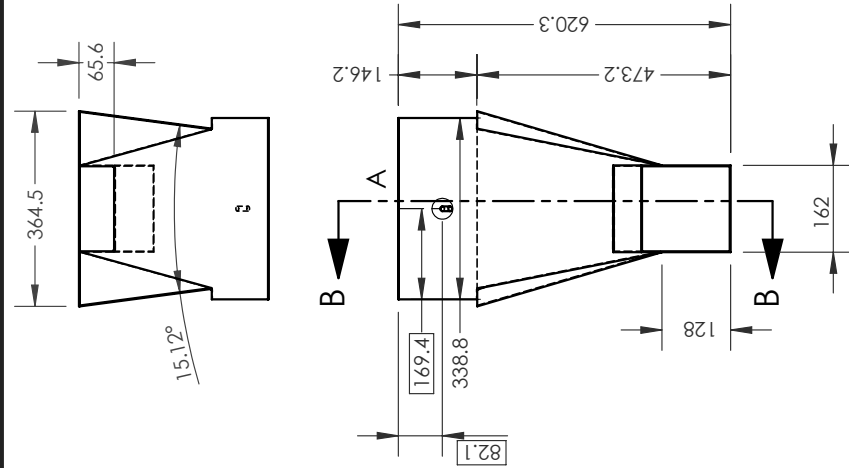

DETAIL A
SCALE 1 : 2

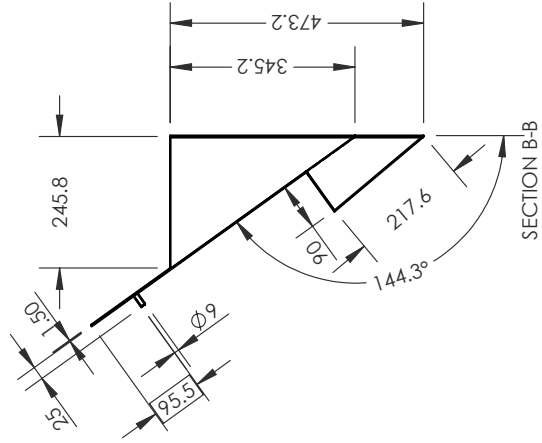

*SHEET THICKNESS: 1.5mm

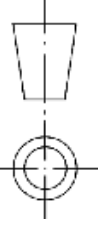
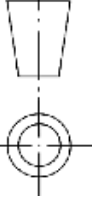
UNLESS OTHERWISE SPECIFIED: STD. TOLERANCE DIMENSIONS ARE IN MILLIMETER MILLIMETER: ±0.1, ANGULAR: ± 0.05° * DOES NOT APPLY TO HOLE SIZE				BANGLADESH RICE RESEARCH INSTITUTE SFMRA PROJECT, FMPHT DIVISION		DO NOT SCALE DRAWING
DETAILS		NAME	SIGNATURE	DATE	FINISH: NONE	
DRAWN		ENGR. SHAFER JAHAN KHAN	S J K	17-AUG-2023	FIRST ISSUED: 02-AUG-2023	
CHK'D		DR. MD. MOSHARRAF HOSSAIN	M M H	18-DEC-2023	TITLE: BRRI COMPACT RICE MILL (BRRI RM2023)	
APP'VD		DR. AKM SAIFUL ISLAM	A S I	30-DEC-2023	DRG. NAME: BOTTOM HOPPER	
THIRD ANGLE PROJECTION:				DWG NO: RM2023_s4-76		
NOTE: DEBURR AND BREAK SHARP EDGES ALL BENDS MIN. RADIUS UNLESS SPECIFIED				MANUFACTURING METHOD: MACHINING, BENDING & WELDING		
		MATERIAL: Plain Carbon Steel		WEIGHT: 4446.20 g		A4
		SCALE: 1:12		SHEET 122		REVISION: A

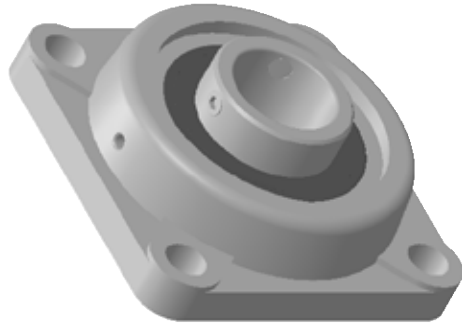

UCF 207 BEARING HOUSING

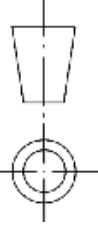
UNLESS OTHERWISE SPECIFIED: STD. TOLERANCE DIMENSIONS ARE IN MILLIMETER MILLIMETER: ± 0.1 , ANGULAR: $\pm 0.05^\circ$ * DOES NOT APPLY TO HOLE SIZE			BANGLADESH RICE RESEARCH INSTITUTE SFMRA PROJECT, FMPHT DIVISION		DO NOT SCALE DRAWING
	DETAILS NAME SIGNATURE DATE		TITLE: BRII COMPACT RICE MILL (BRII RM2023)		FINISH: NONE
DRAWN ENGR. SHAFER JAHAN KHAN S J K 17-AUG-2023	CHK'D DR. MD. MOSHARRAF HOSSAIN M M H 18-DEC-2023		DRG. NAME: UCP 207		FIRST ISSUED: 02-AUG-2023
APP'D DR. AKM SAIBUL ISLAM A S I 30-DEC-2023	THIRD ANGLE PROJECTION: 		DWG NO: RM2023_S4-77		
NOTE: DEBURR AND BREAK SHARP EDGES ALL BENDS MIN. RADIUS UNLESS SPECIFIED			FINDING: SHOP		
			MATERIAL:		WEIGHT: g
			SCALE: 1:5	SHEET 123	REVISION:
					A

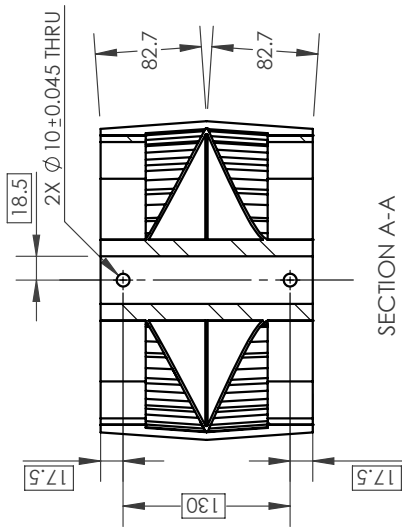

SECTION A-A

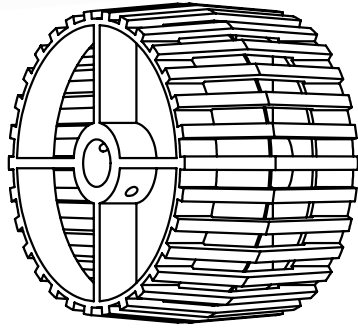
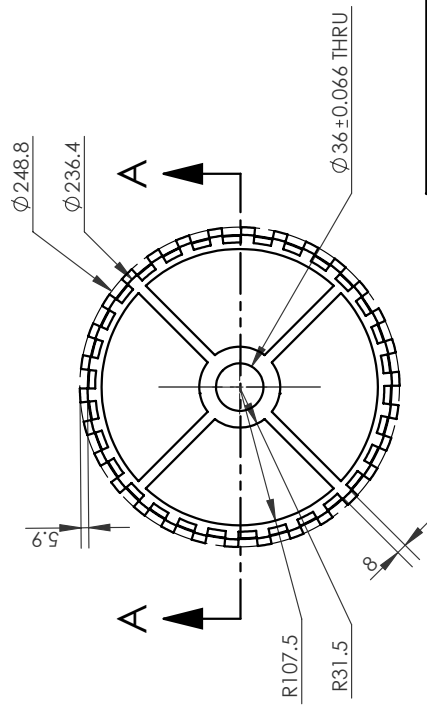

*NUMBER OF RIB: 30
*ELEVATOR BOTTOM PULLEY.

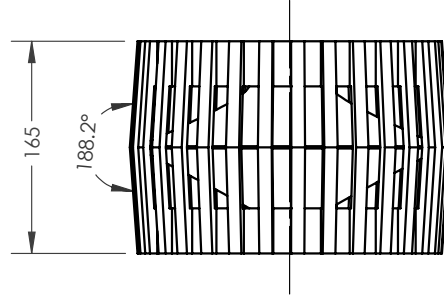

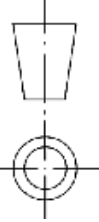
		BANGLADESH RICE RESEARCH INSTITUTE SFMRA PROJECT, FMPHT DIVISION		DO NOT SCALE DRAWING
		TITLE: BRRI COMPACT RICE MILL (BRRI RM2023)		FINISH: NONE
UNLESS OTHERWISE SPECIFIED: STD. TOLERANCE DIMENSIONS ARE IN MILLIMETER MILLIMETER: ±0.1, ANGULAR: ± 0.05° * DOES NOT APPLY TO HOLE SIZE		SIGNATURE S. J.K.	DATE 18-AUG-2023	FIRST ISSUED: 02-AUG-2023
DRAWN ENGR. SHAFER JAHAN RHAN	M. M. H.	18-DEC-2023	DRG. NAME: FLAT BELT PULLEY DWG NO: RM2023_s4-78	
APP'D DR. AKM SAIBUL ISLAM	A. S. I.	30-DEC-2023		
THIRD ANGLE PROJECTION: 			MANUFACTURING METHOD: MACHINING, BENDING & WELDING	
NOTE: DEBURR AND BREAK SHARP EDGES ALL BENDS MIN. RADIUS UNLESS SPECIFIED			MATERIAL: ASTM A36 Steel	WEIGHT: 9884.28 g
SCALE: 1:5			SHEET 124	REVISION: A

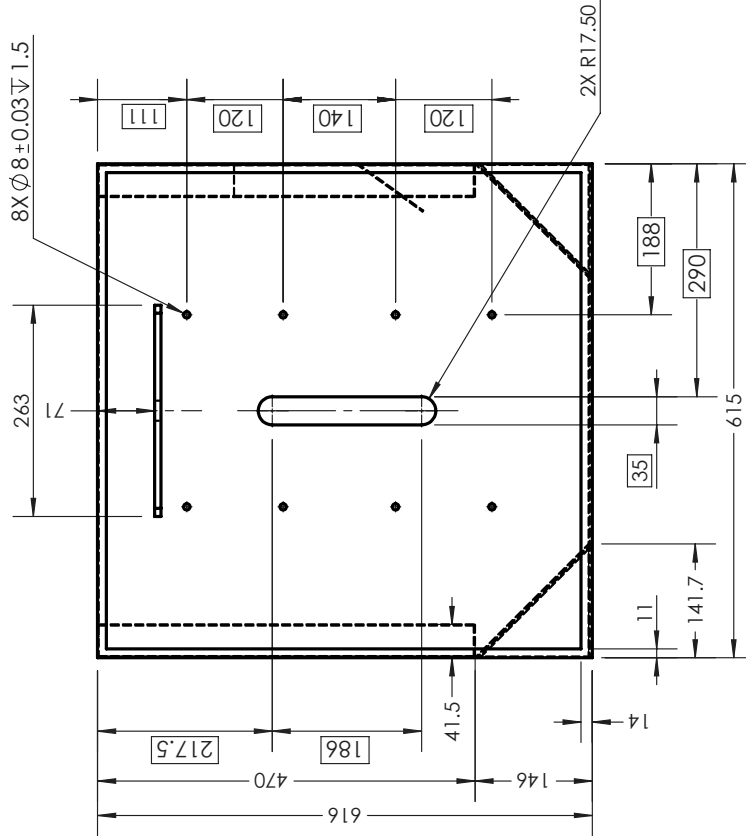
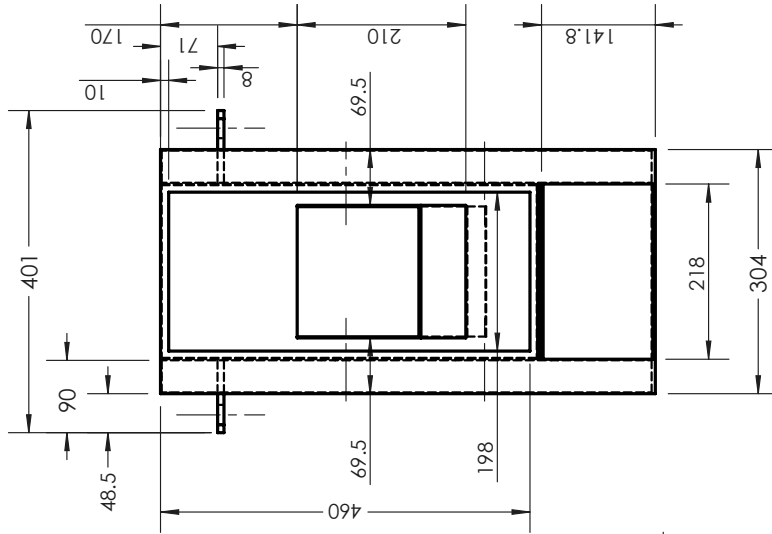
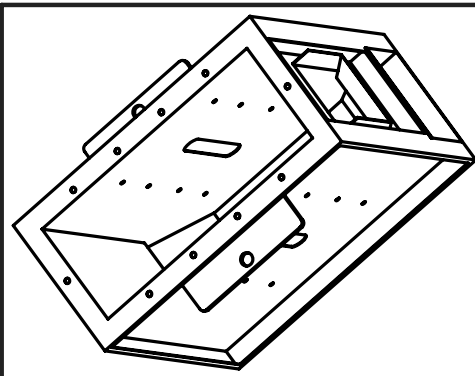

BANGLADESH RICE RESEARCH INSTITUTE SFMRA PROJECT, FMPHT DIVISION		DO NOT SCALE DRAWING FINISH: NONE FIRST ISSUED: 02-AUG-2023	
		TITLE: BRRI COMPACT RICE MILL (BRRI RM2023)	
UNLESS OTHERWISE SPECIFIED: STD. TOLERANCE DIMENSIONS ARE IN MILLIMETER MILLIMETER: ±0.1, ANGULAR: ± 0.05° * DOES NOT APPLY TO HOLE SIZE	DETAILS NAME DRAWN ENGR. SHAFER JAHAN RHAN CHK'D DR. MD. MOSHARRAF HOSSAIN APP'VD DR. AKKI SAIBUL ISLAM	SIGNATURE S J K M M H A S I	DATE 17-AUG-2023 18-DEC-2023 30-DEC-2023
DRG. NAME: BOTTOM CASING DWG NO: RM2023_s4-79		DRG. NAME: BOTTOM CASING DWG NO: RM2023_s4-79	
MANUFACTURING METHOD: MACHINING, BENDING & WELDING		MATERIAL: Plain Carbon Steel	
SCALE: 1:12		WEIGHT: 24805.65 g	
SHEET 125		REVISION: A	

N.B: ONLY FRONT & RIGHT SIDE MEASUREMENTS HAS SHOWN HERE. TOP VIEW IS IN NEXT SHEET.

***SHEET THICKNESS: 1.5mm**

***BENDING RADIUS: 2mm**

***MODEL IS SYMMETRY.**

***ONE SIDE SIZES HAS SHOWN HERE.**

NOTE: DEBURR AND BREAK SHARP EDGES ALL BENDS MIN. RADIUS UNLESS SPECIFIED

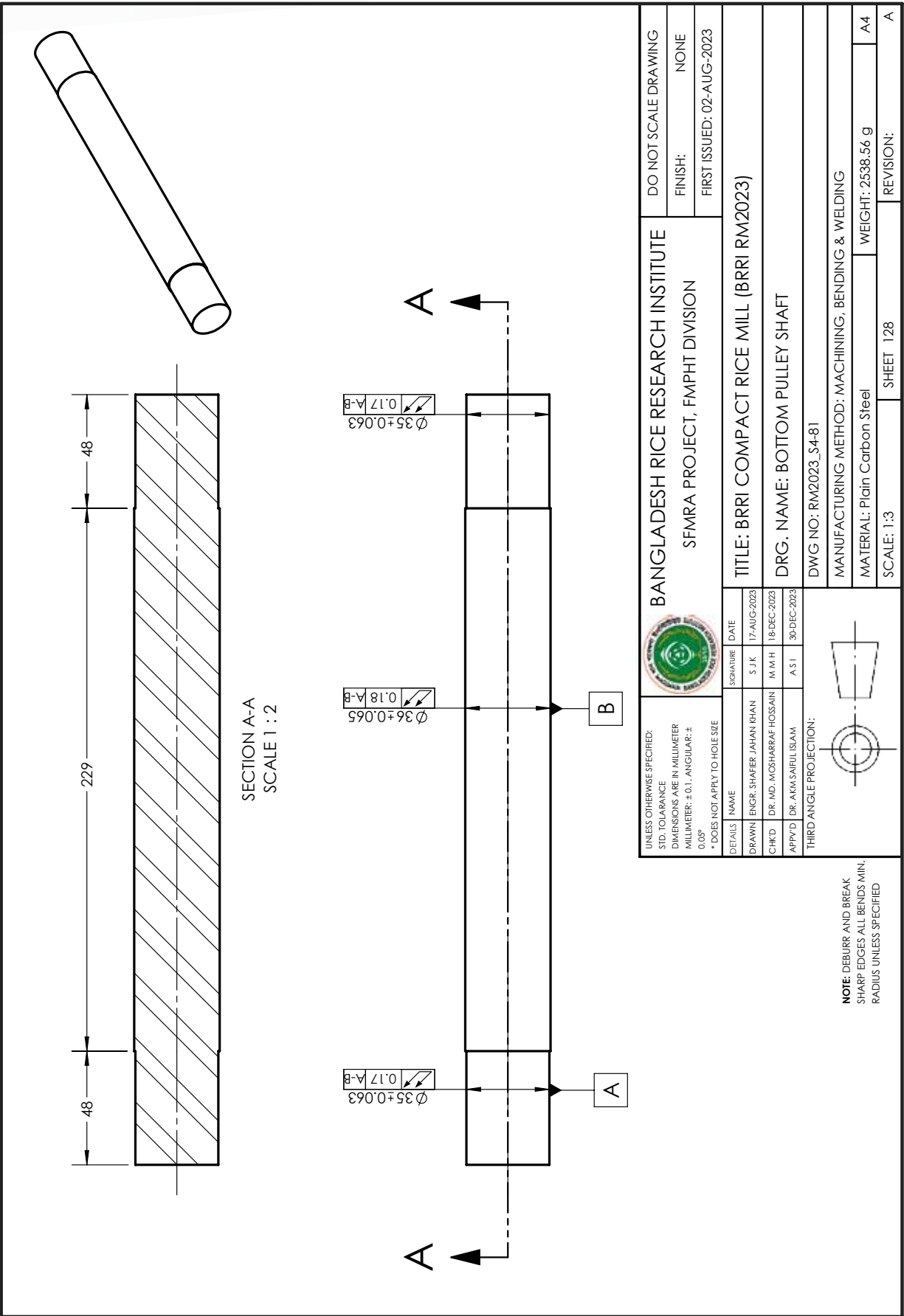

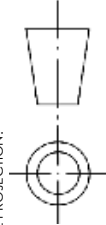
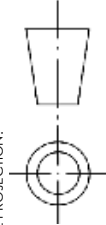

SECTION A-A
SCALE 1 : 2

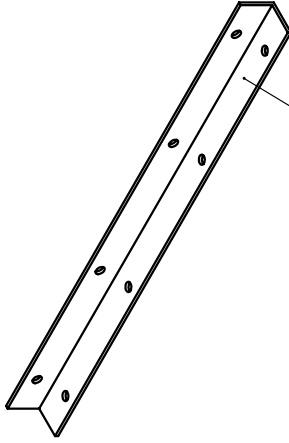
UNLESS OTHERWISE SPECIFIED: STD. TOLERANCE DIMENSIONS ARE IN MILLIMETER MILLIMETER: ±0.1, ANGULAR: ± 0.05° * DOES NOT APPLY TO HOLE SIZE				BANGLADESH RICE RESEARCH INSTITUTE SFMRA PROJECT, FMPHT DIVISION		DO NOT SCALE DRAWING
DETAILS		NAME	SIGNATURE	DATE	FINISH: NONE	
DRAWN		ENGR. SHAFER JAHAN RHAN	S J K	17-AUG-2023	FIRST ISSUED: 02-AUG-2023	
CHK'D		DR. MD. MOSHARRAF HOSSAIN	M M H	18-DEC-2023	TITLE: BRRI COMPACT RICE MILL (BRRI RM2023)	
APP'D		DR. AKM SAIBUL ISLAM	A S I	30-DEC-2023	DRG. NAME: BOTTOM PULLEY SHAFT	
THIRD ANGLE PROJECTION:				DWG NO: RM2023_s4-81		
NOTE: DEBURR AND BREAK SHARP EDGES ALL BENDS MIN. RADIUS UNLESS SPECIFIED				MANUFACTURING METHOD: MACHINING, BENDING & WELDING		
		MATERIAL: Plain Carbon Steel		WEIGHT: 2538.56 g		A4
		SCALE: 1:3		SHEET 128		REVISION: A

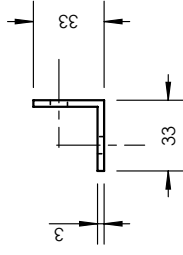
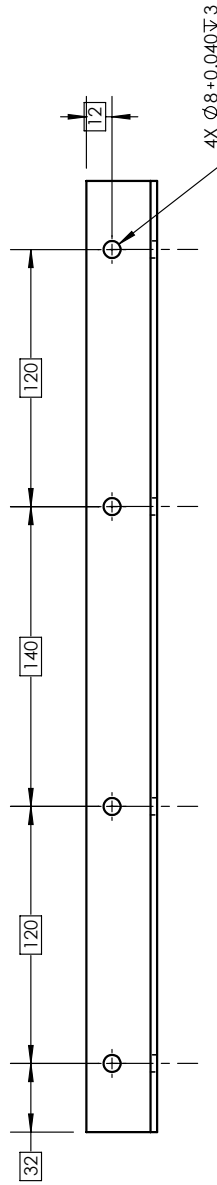
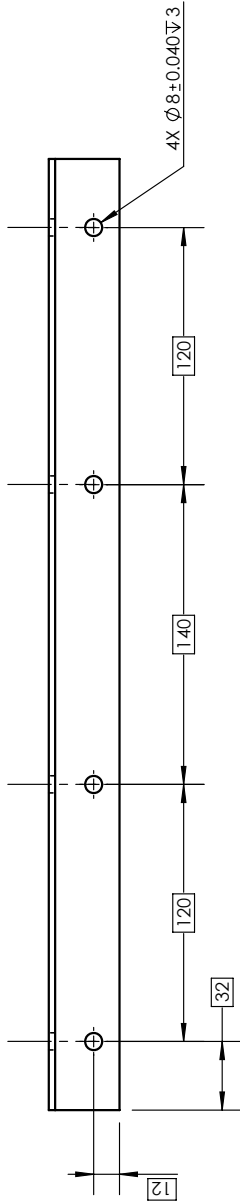

33X33X3 ANGLE BAR

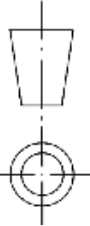

UNLESS OTHERWISE SPECIFIED: STD. TOLERANCE DIMENSIONS ARE IN MILLIMETER MILLIMETER: ±0.1, ANGULAR: ±0.05° * DOES NOT APPLY TO HOLE SIZE				BANGLADESH RICE RESEARCH INSTITUTE SFMRA PROJECT, FMPHT DIVISION		DO NOT SCALE DRAWING	
DETAILS	NAME	SIGNATURE	DATE	DRG. NAME: BTM-C-ANGLE BAR		FINISH: NONE	
DRAWN	ENGR. SHAFER JAHAN RHAN	S. J.K	17-AUG-2023	DWG NO: RM2023_S4-82		FIRST ISSUED: 02-AUG-2023	
CHK'D	DR. MD. MOSHARRAF HOSSAIN	M. M.H	18-DEC-2023	TITLE: BRRI COMPACT RICE MILL (BRRI RM2023)			
APP'VD	DR. AKM SAIFUL ISLAM	A.S.I	30-DEC-2023	DRG. NAME: BTM-C-ANGLE BAR			
THIRD ANGLE PROJECTION:							
NOTE: DEBURR AND BREAK SHARP EDGES ALL BENDS MIN. RADIUS UNLESS SPECIFIED				MANUFACTURING METHOD: MACHINING, BENDING & WELDING			
				MATERIAL: ASTM A36 Steel		WEIGHT: 649.27 g	
				SCALE: 1:5		REVISION: A	
				SHEET 129			

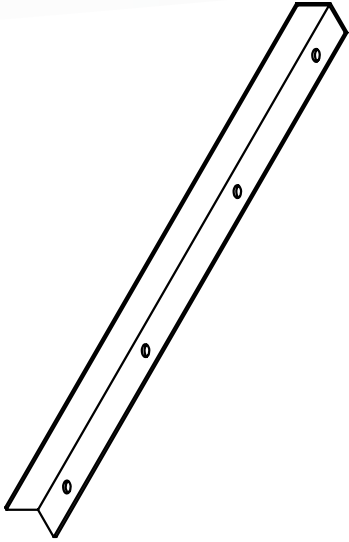
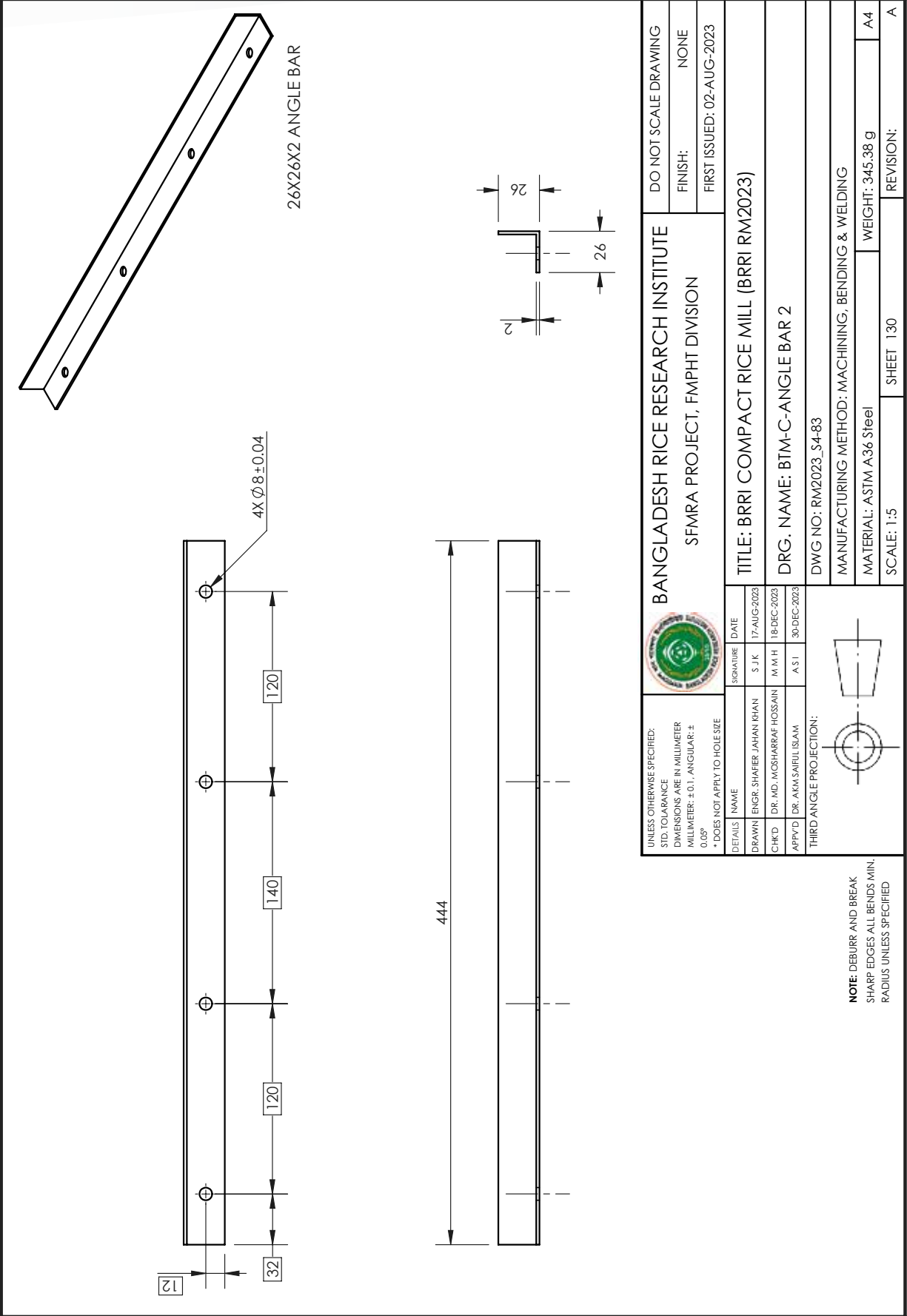

26X26X2 ANGLE BAR

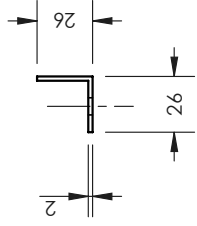
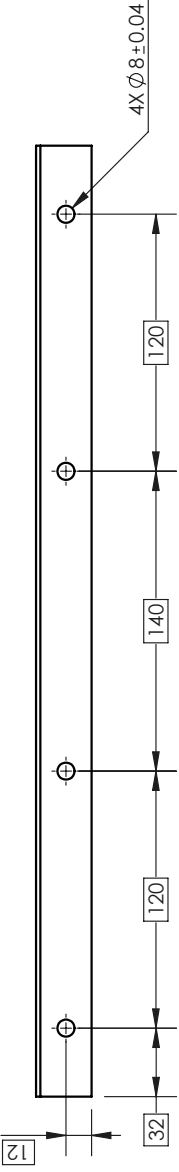

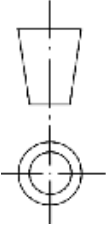

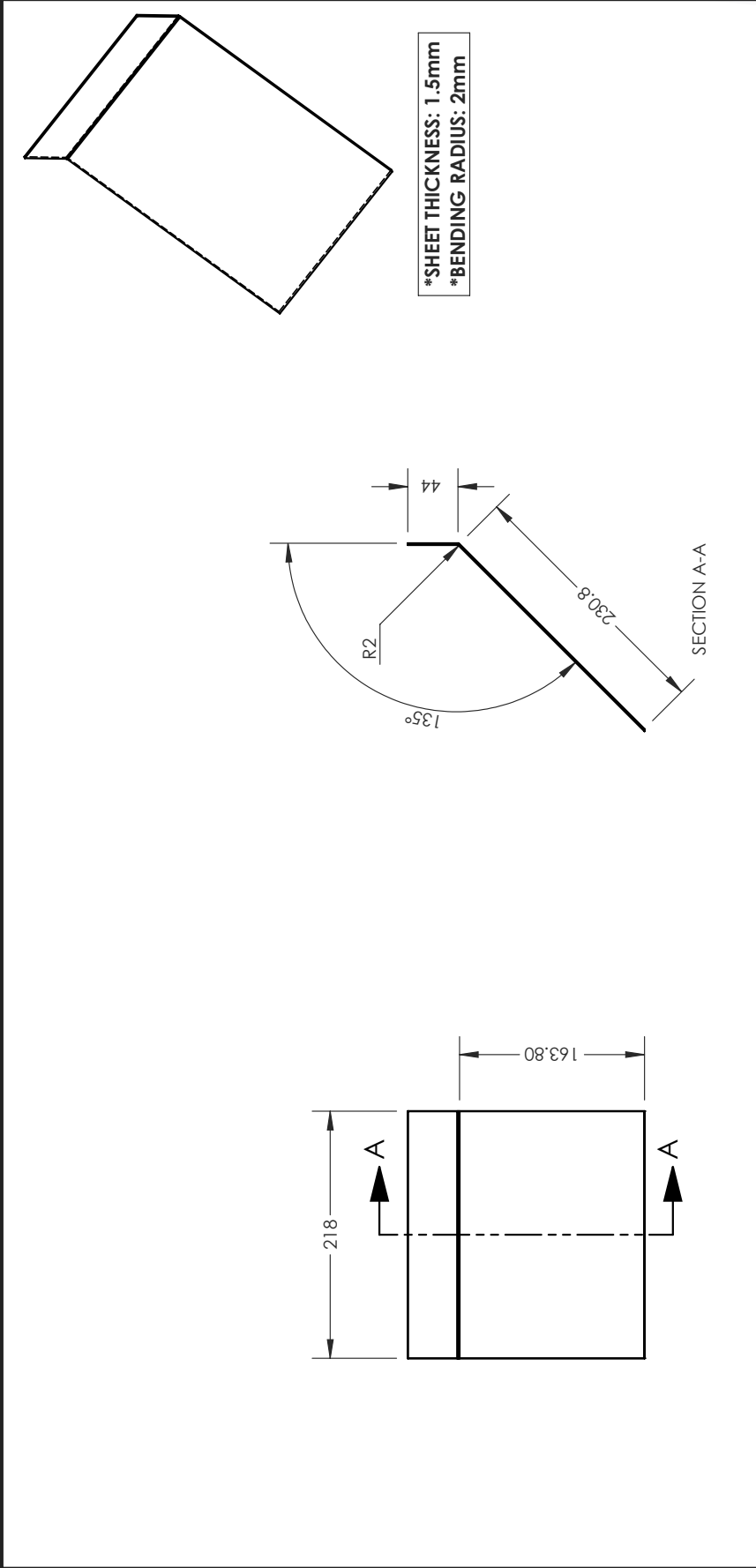
UNLESS OTHERWISE SPECIFIED: STD. TOLERANCE DIMENSIONS ARE IN MILLIMETER MILLIMETER: ±0.1, ANGULAR: ±0.05° * DOES NOT APPLY TO HOLE SIZE				BANGLADESH RICE RESEARCH INSTITUTE SFMRA PROJECT, FMPHT DIVISION		DO NOT SCALE DRAWING	
DETAILS	NAME	SIGNATURE	DATE	FINISH: NONE			
DRAWN	ENGR. SHAFER JAHAN RHAN	S J K	17-AUG-2023	FIRST ISSUED: 02-AUG-2023			
CHK'D	DR. MD. MOSHARRAF HOSSAIN	M M H	18-DEC-2023	TITLE: BRRI COMPACT RICE MILL (BRRI RM2023)			
APP'VD	DR. AKM SAIBUL ISLAM	A S I	30-DEC-2023	DRG. NAME: BTM-C-ANGLE BAR 2			
THIRD ANGLE PROJECTION:				DWG NO: RM2023_s4-83			
				MANUFACTURING METHOD: MACHINING, BENDING & WELDING			
NOTE: DEBURR AND BREAK SHARP EDGES ALL BENDS MIN. RADIUS UNLESS SPECIFIED				MATERIAL: ASTM A36 Steel		WEIGHT: 345.38 g	
				SCALE: 1:5		REVISION: A	
				SHEET 1/30		A	

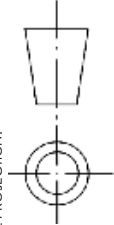

UNLESS OTHERWISE SPECIFIED: STD. TOLERANCE DIMENSIONS ARE IN MILLIMETER MILLIMETER: ±0.1, ANGULAR: ±0.05° * DOES NOT APPLY TO HOLE SIZE				BANGLADESH RICE RESEARCH INSTITUTE SFMRA PROJECT, FMPHT DIVISION		DO NOT SCALE DRAWING	
DETAILS	NAME	SIGNATURE	DATE	TITLE: BRRI COMPACT RICE MILL (BRRI RM2023)		FINISH:	NONE
DRAWN	ENGR. SHAFER JAHAN RHAN	S J K	17-AUG-2023	DRG. NAME: BTM-CONTROL GATE		FIRST ISSUED:	02-AUG-2023
CHK'D	DR. MD. MOSHARRAF HOSSAIN	M M H	18-DEC-2023	DWG NO: RM2023_S4-84			
APP'D	DR. AKM SAIFUL ISLAM	A S I	30-DEC-2023	MANUFACTURING METHOD: MACHINING, BENDING & WELDING			
THIRD ANGLE PROJECTION:						MATERIAL: Plain Carbon Steel	
				SCALE: 1:5		REVISION: A	
				SHEET 1/31		WEIGHT: 705.79 g	
						A4	

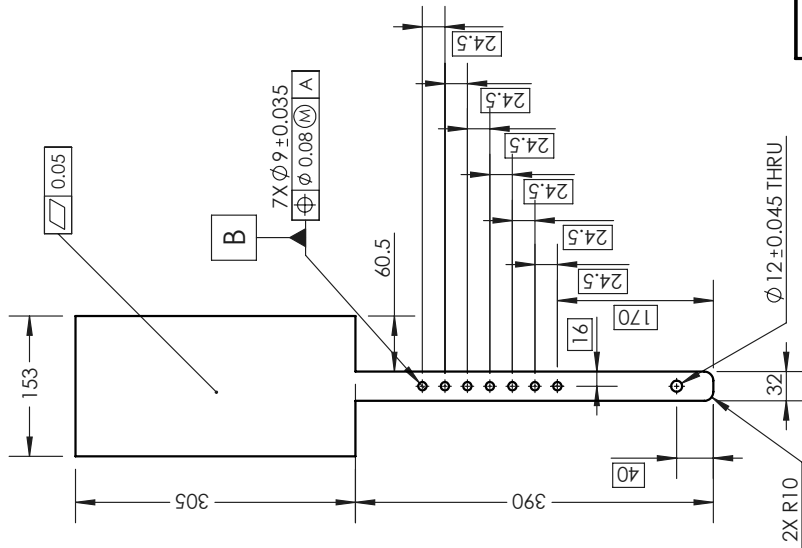
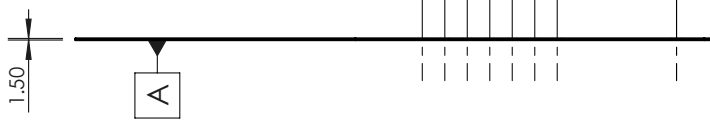
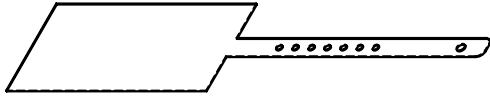
NOTE: DEBURR AND BREAK SHARP EDGES ALL BENDS MIN. RADIUS UNLESS SPECIFIED

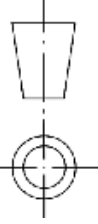
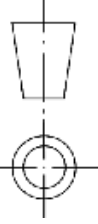

UNLESS OTHERWISE SPECIFIED: STD. TOLERANCE DIMENSIONS ARE IN MILLIMETER MILLIMETER: ±0.1, ANGULAR: ±0.05° * DOES NOT APPLY TO HOLE SIZE				BANGLADESH RICE RESEARCH INSTITUTE SFMRA PROJECT, FMPHT DIVISION		DO NOT SCALE DRAWING	
DETAILS		NAME	SIGNATURE	DATE	FINISH: NONE		
DRAWN		ENGR. SHAFER JAHAN RHAN	S J K	17-AUG-2023	FIRST ISSUED: 02-AUG-2023		
CHK'D		DR. MD. MOSHARRAF HOSSAIN	M M H	18-DEC-2023	TITLE: BRRI COMPACT RICE MILL (BRRI RM2023)		
APP'VD		DR. AKM SAIBUL ISLAM	A S I	30-DEC-2023	DRG. NAME: HOPPER GATE CONTROLLER		
THIRD ANGLE PROJECTION:				DWG NO: RM2023_s4-85			
NOTE: DEBURR AND BREAK SHARP EDGES ALL BENDS MIN. RADIUS UNLESS SPECIFIED				MANUFACTURING METHOD: MACHINING, BENDING & WELDING			
		SCALE: 1:7		SHEET 1/32		WEIGHT: 689.35 g	
						REVISION: A	

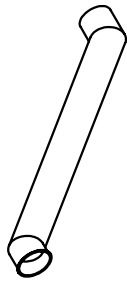



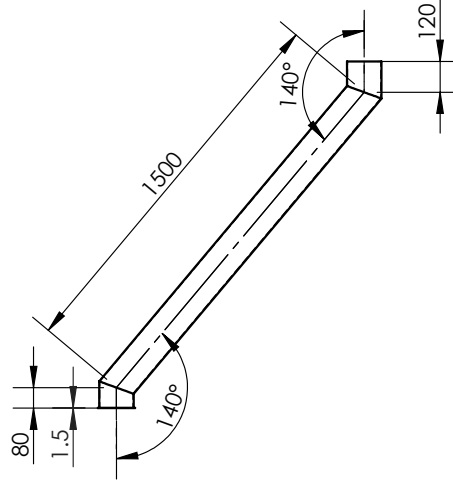
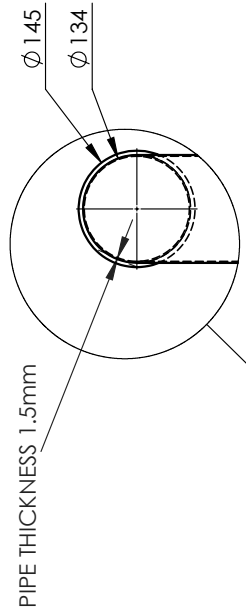

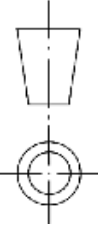
***PADDY TRANSFER LINE.**

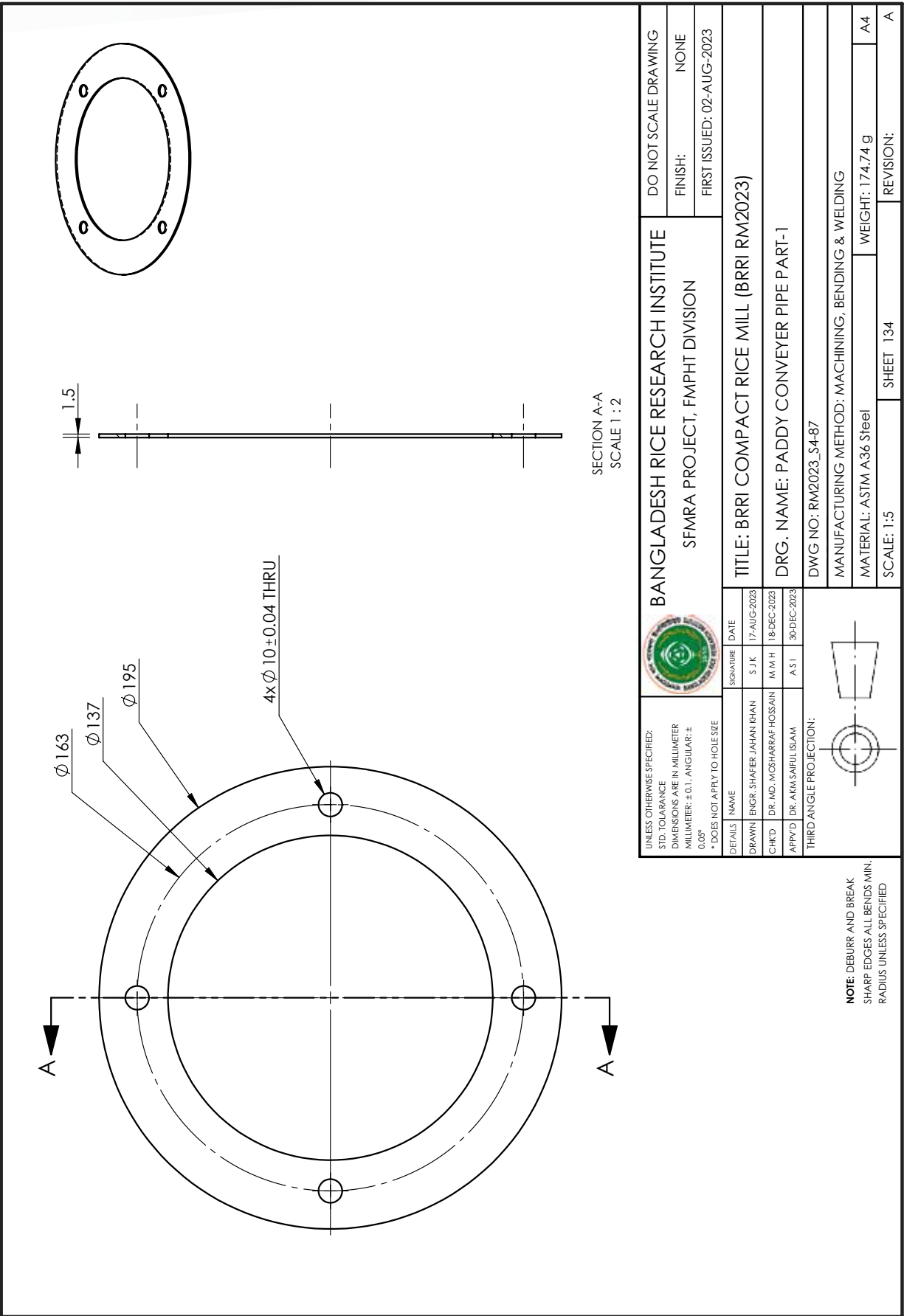

UNLESS OTHERWISE SPECIFIED: STD. TOLERANCE DIMENSIONS ARE IN MILLIMETER MILLIMETER: ±0.1, ANGULAR: ± 0.05° * DOES NOT APPLY TO HOLE SIZE		 BANGLADESH RICE RESEARCH INSTITUTE SFMRA PROJECT, FMPHT DIVISION		DO NOT SCALE DRAWING
DETAILS		NAME	SIGNATURE	DATE
CHK'D	DR. MD. MOSHARRAF HOSSAIN	M. M. H.	S. J. K.	17-AUG-2023
APP'D	DR. AKM SAIFUL ISLAM	A. S. I.	M. M. H.	18-DEC-2023
THIRD ANGLE PROJECTION:				
TITLE: BRRI COMPACT RICE MILL (BRRI RM2023)		DRG. NAME: PADDY TRANSFER LINE		
DWG NO: RM2023_s4-86		MANUFACTURING METHOD: MACHINING, BENDING & WELDING		
MATERIAL: ASTM A36 Steel		WEIGHT: 8745.74 g		
SCALE: 1:25		REVISION: A		
SHEET 1/33		A		

NOTE: DEBURR AND BREAK SHARP EDGES ALL BENDS MIN. RADIUS UNLESS SPECIFIED

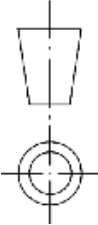

UNLESS OTHERWISE SPECIFIED: STD. TOLERANCE DIMENSIONS ARE IN MILLIMETER MILLIMETER: ±0.1, ANGULAR: ±0.05° * DOES NOT APPLY TO HOLE SIZE				BANGLADESH RICE RESEARCH INSTITUTE SFMRA PROJECT, FMPHT DIVISION		DO NOT SCALE DRAWING	
DETAILS		NAME	SIGNATURE	DATE	FINISH: NONE		
DRAWN		ENGR. SHAFER JAHAN KHAN	S. J.K	17-AUG-2023	FIRST ISSUED: 02-AUG-2023		
CHK'D		DR. MD. MOSHARRAF HOSSAIN	M. M.H	18-DEC-2023	TITLE: BRRI COMPACT RICE MILL (BRRI RM2023)		
APP'VD		DR. AKM SAIBUL ISLAM	A.S.I	30-DEC-2023	DRG. NAME: PADDY CONVEYER PIPE PART-1		
THIRD ANGLE PROJECTION:				DWG NO: RM2023_S4-87			
NOTE: DEBURR AND BREAK SHARP EDGES ALL BENDS MIN. RADIUS UNLESS SPECIFIED				MANUFACTURING METHOD: MACHINING, BENDING & WELDING			
				MATERIAL: ASTM A36 Steel		WEIGHT: 174.74 g	
				SCALE: 1:5		REVISION: A	
				SHEET 134		A	

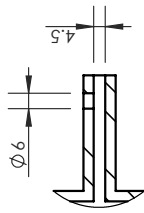
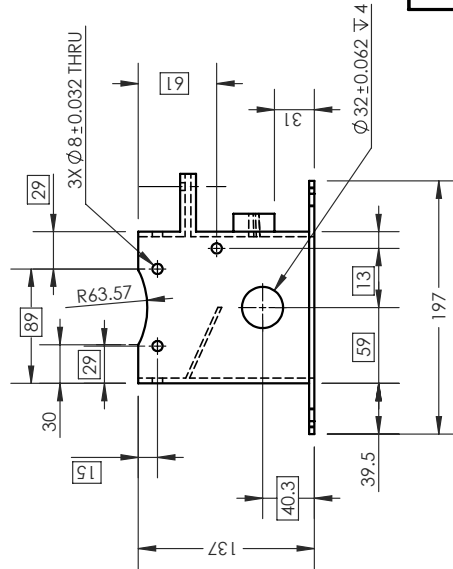
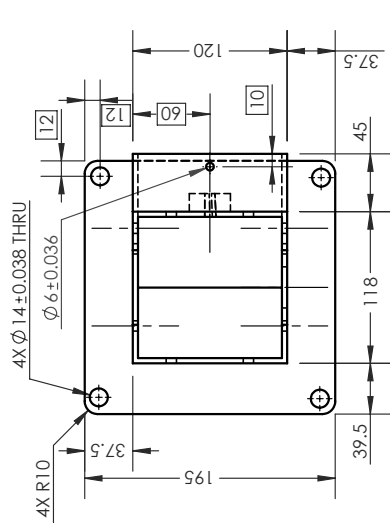

DETAIL B
SCALE 2 : 5

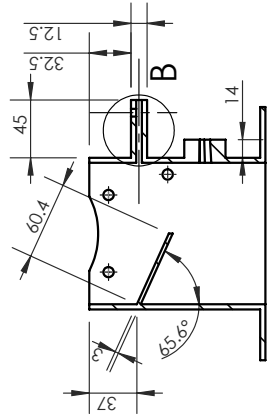

BROKEN OUT SECTION - A
FROM FRONT VIEW
SCALE 1:5

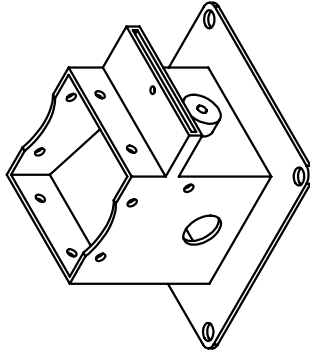

*SHEET THICKNESS 4mm.

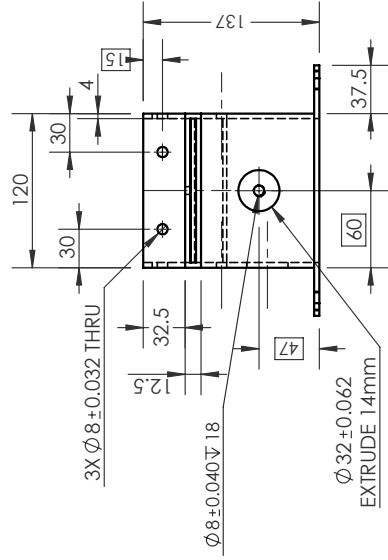

BANGLADESH RICE RESEARCH INSTITUTE
SFMRA PROJECT, FMPHT DIVISION

DO NOT SCALE DRAWING
FINISH: NONE
FIRST ISSUED: 02-AUG-2023

TITLE: BRRI COMPACT RICE MILL (BRRI RM2023)

DRG. NAME: PADDY HOPPER BODY PART

DWG NO: RM2023_s5-88

MANUFACTURING METHOD: MACHINING, BENDING & WELDING

MATERIAL: Plain Carbon Steel

WEIGHT: 3202.01 g

A4

REVISION:

SHEET 135

SCALE: 1:5





THIRD ANGLE PROJECTION:

NOTE: DEBURR AND BREAK SHARP EDGES ALL BENDS MIN. RADIUS UNLESS SPECIFIED

UNLESS OTHERWISE SPECIFIED:
STD. TOLERANCE DIMENSIONS ARE IN MILLIMETER
MILLIMETER: ±0.1, ANGULAR: ±0.05°
* DOES NOT APPLY TO HOLE SIZE

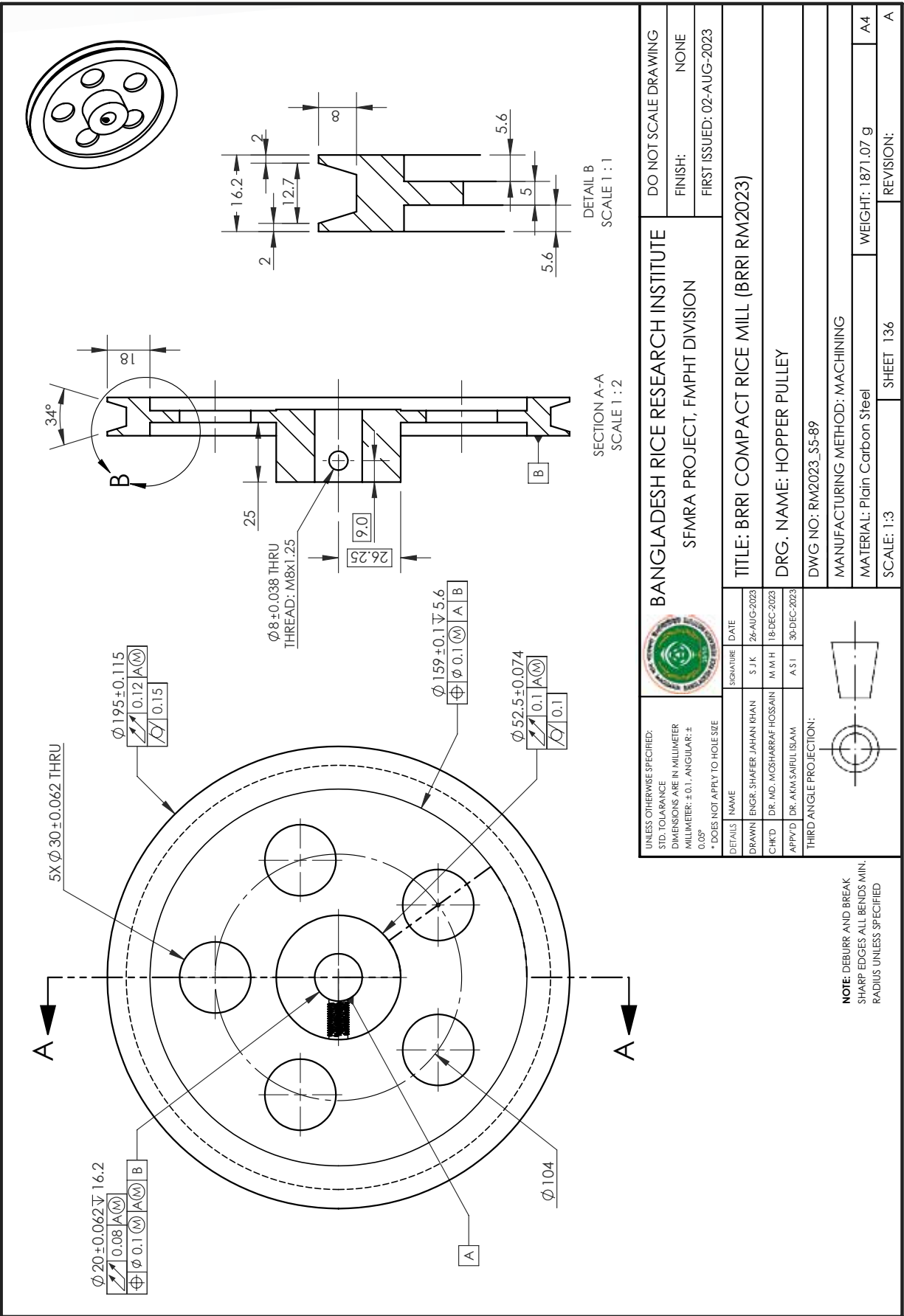
DETAILS	NAME	SIGNATURE	DATE
DRAWN	ENGR. SHAFER JAHAN KHAN	S J K	26-AUG-2023
CHK'D	DR. MD. MOSHARRAF HOSSAIN	M M H	18-DEC-2023
APP'VD	DR. AKM SAIBUL ISLAM	A S I	30-DEC-2023

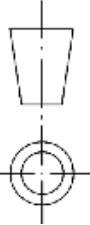

		BANGLADESH RICE RESEARCH INSTITUTE SFMRA PROJECT, FMPHT DIVISION		DO NOT SCALE DRAWING
		TITLE: BRRI COMPACT RICE MILL (BRRI RM2023)		FINISH: NONE
UNLESS OTHERWISE SPECIFIED: STD. TOLERANCE DIMENSIONS ARE IN MILLIMETER MILLIMETER: ±0.1, ANGULAR: ±0.05° * DOES NOT APPLY TO HOLE SIZE		SIGNATURE S. J.K.	DATE 26-AUG-2023	FIRST ISSUED: 02-AUG-2023
DRAWN ENGR. SHAFER JAHAN RHAN	M. M. H.	18-DEC-2023	DRG. NAME: HOPPER PULLEY DWG NO: RM2023_s5-89	
APP'D DR. AKM SAIBUL ISLAM	A. S. I.	30-DEC-2023		
THIRD ANGLE PROJECTION: 			MANUFACTURING METHOD: MACHINING	
NOTE: DEBURR AND BREAK SHARP EDGES ALL BENDS MIN. RADIUS UNLESS SPECIFIED			MATERIAL: Plain Carbon Steel	WEIGHT: 1871.07 g
SCALE: 1:3			SHEET 136	REVISION: A

SECTION A-A
SCALE 1 : 2

DETAIL B
SCALE 1 : 1

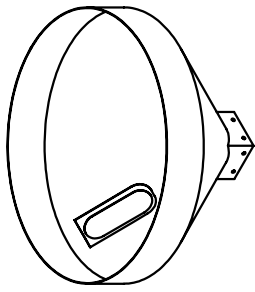

N.B: ONLY FRONT & RIGHT VIEW HAS SHOWN HERE.
 *NOT A COMPLETE DRAWING.
 *SHEET THICKNESS: 1.5mm.

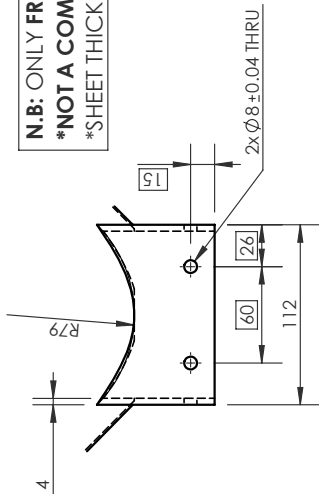



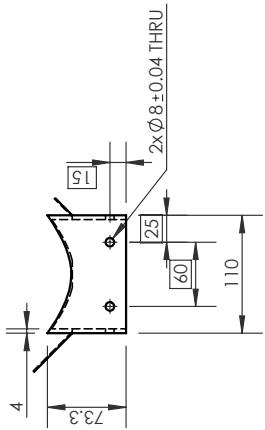

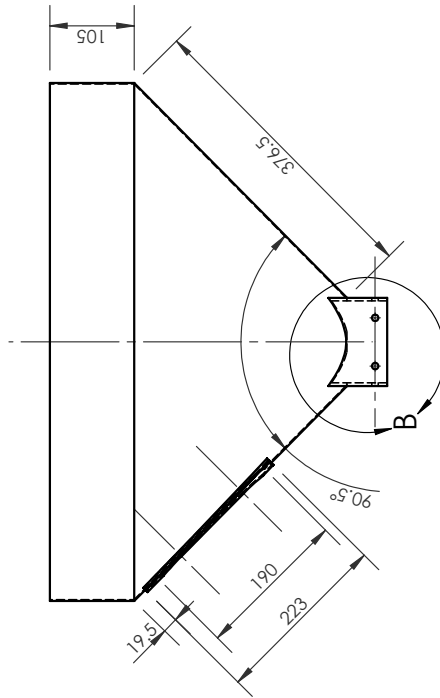
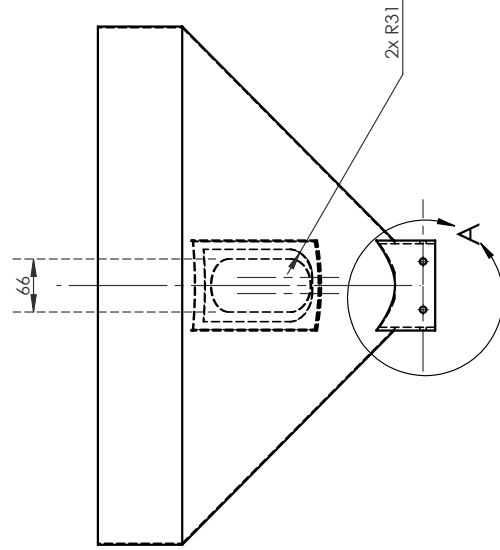

DETAIL A
 SCALE 1 : 4

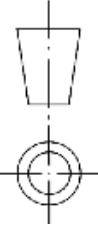

DETAIL B
 SCALE 1 : 6



UNLESS OTHERWISE SPECIFIED: STD. TOLERANCE DIMENSIONS ARE IN MILLIMETER MILLIMETER: ±0.1, ANGULAR: ±0.05° * DOES NOT APPLY TO HOLE SIZE				BANGLADESH RICE RESEARCH INSTITUTE SFMRA PROJECT, FMPHT DIVISION		DO NOT SCALE DRAWING
DETAILS	NAME	SIGNATURE	DATE			FINISH: NONE
DRAWN	ENGR. SHAFER JAHAN RHAN	S J K	26-AUG-2023			FIRST ISSUED: 02-AUG-2023
CHK'D	DR. MD. MOSHARRAF HOSSAIN	M M H	18-DEC-2023	TITLE: BRRI COMPACT RICE MILL (BRRI RM2023)		
APP'VD	DR. AKM SAIBUL ISLAM	A S I	30-DEC-2023	DRG. NAME: PADDY HOPPER CASING		
THIRD ANGLE PROJECTION:					DWG NO: RM2023_s5-90	
					MANUFACTURING METHOD: MACHINING, BENDING & WELDING	
					MATERIAL: Plain Carbon Steel	
					SCALE: 1:10	
					WEIGHT: 6922.43 g	
					REVISION: A	
					SHEET 137	

NOTE: DEBURR AND BREAK
 SHARP EDGES ALL BENDS MIN.
 RADIUS UNLESS SPECIFIED

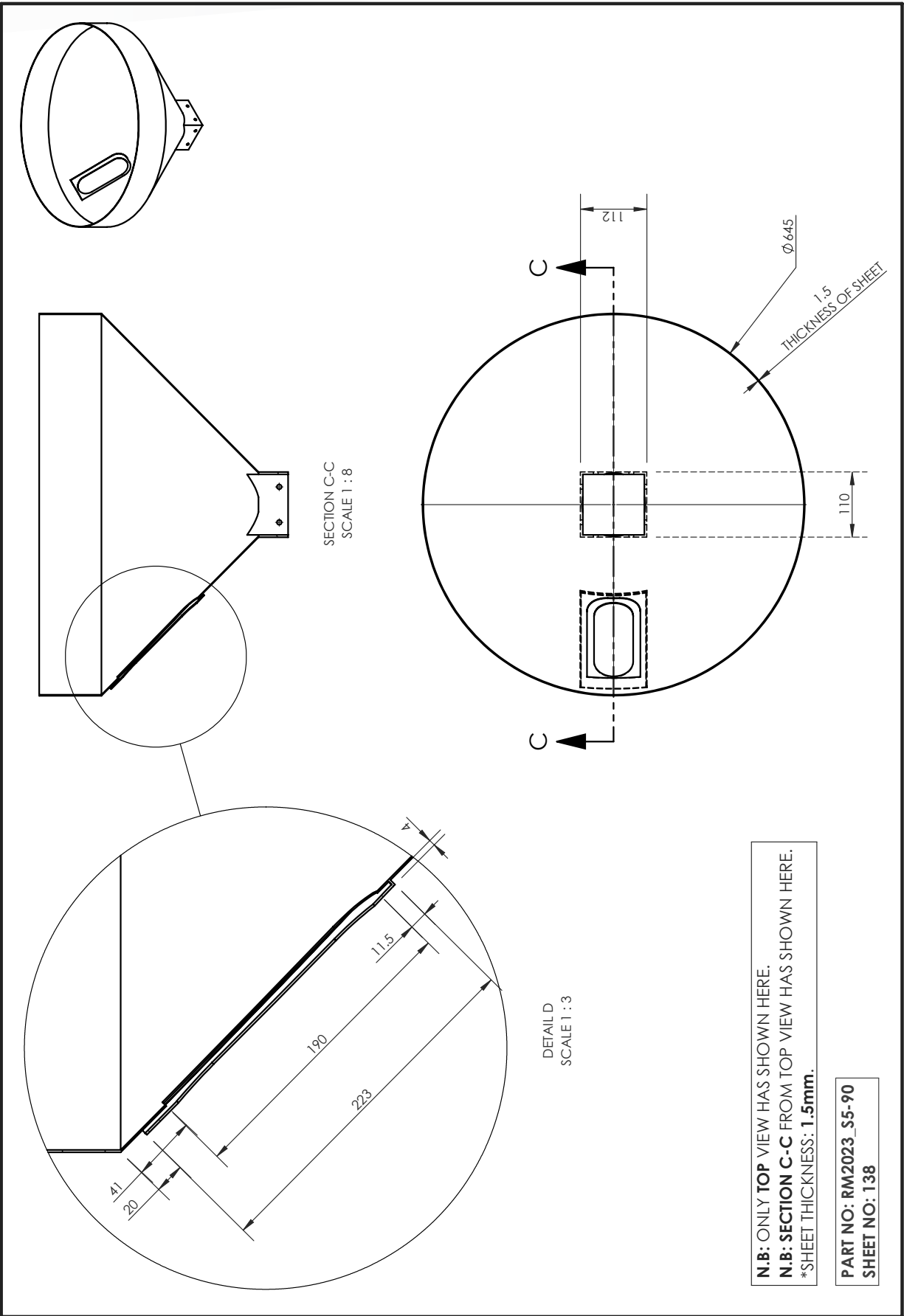

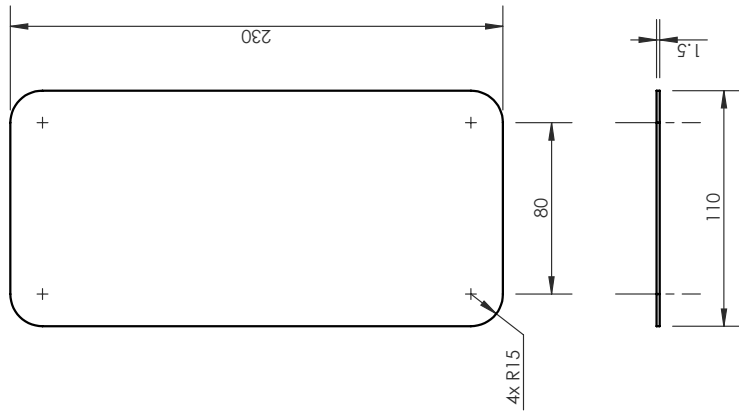
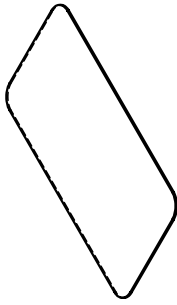

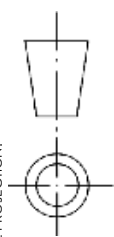
UNLESS OTHERWISE SPECIFIED: STD. TOLERANCE DIMENSIONS ARE IN MILLIMETER MILLIMETER: ±0.1, ANGULAR: ± 0.05° * DOES NOT APPLY TO HOLE SIZE				BANGLADESH RICE RESEARCH INSTITUTE SFMRA PROJECT, FMPHT DIVISION		DO NOT SCALE DRAWING	
DETAILS	NAME	SIGNATURE	DATE	TITLE: BRRI COMPACT RICE MILL (BRRI RM2023)			
DRAWN	ENGR. SHAFER JAHAN KHAN	S. J.K	26-AUG-2023	FINISH: NONE		FIRST ISSUED: 02-AUG-2023	
CHK'D	DR. MD. MOSHARRAF HOSSAIN	M. M.H	18-DEC-2023	DRG. NAME: PADDY HOPPER CASING			
APP'VD	DR. AKM SAIBUL ISLAM	A.S.I	30-DEC-2023	DWG NO: RM2023_S5-91			
THIRD ANGLE PROJECTION:							
NOTE: DEBURR AND BREAK SHARP EDGES ALL BENDS MIN. RADIUS UNLESS SPECIFIED							
MANUFACTURING METHOD: MACHINING, BENDING & WELDING		MATERIAL: Plain Carbon Steel		SCALE: 1:5		SHEET 139	
WEIGHT: 293.75 g		REVISION: A		A			

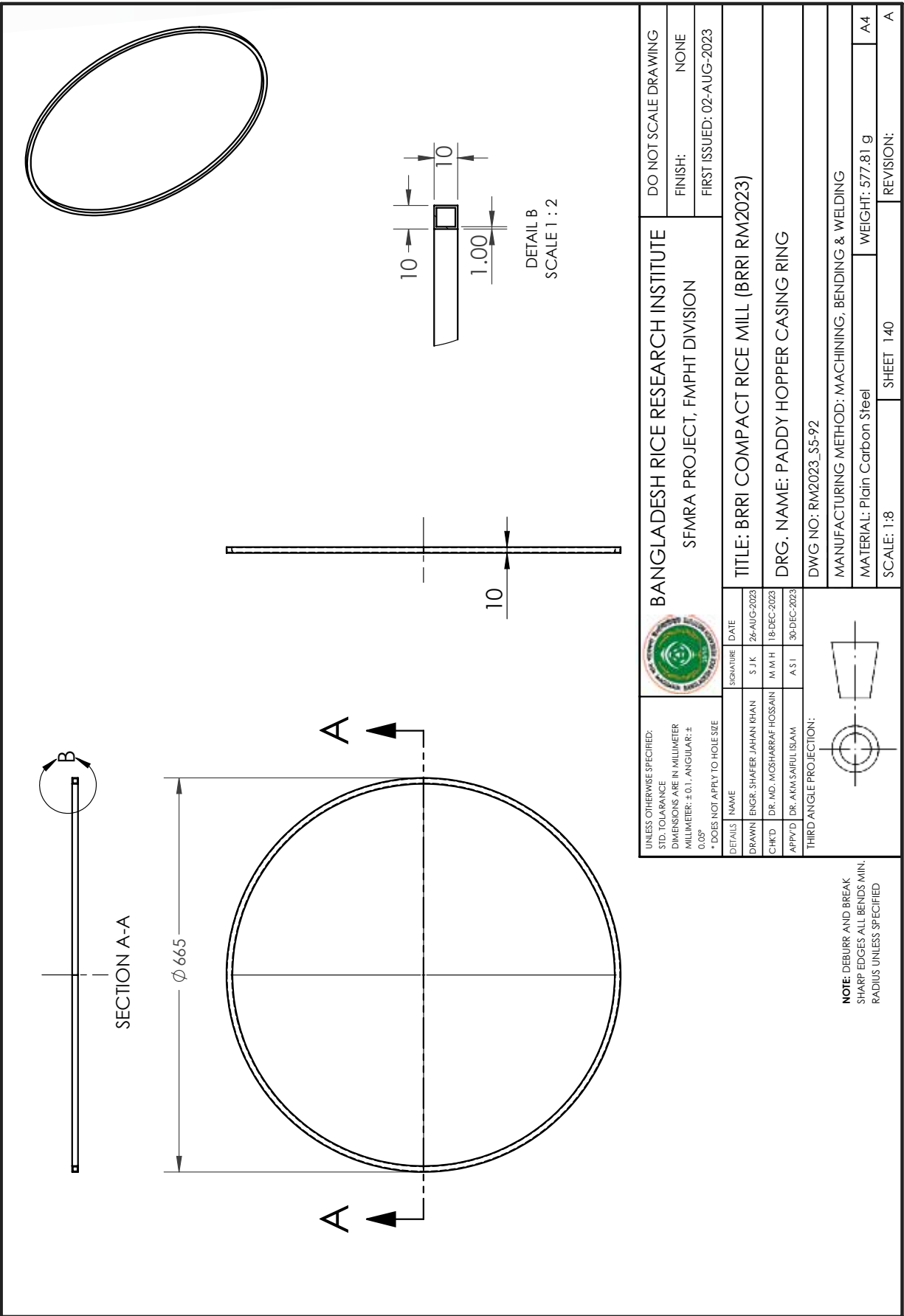

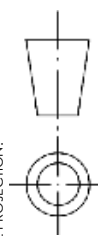
UNLESS OTHERWISE SPECIFIED: STD. TOLERANCE DIMENSIONS ARE IN MILLIMETER MILLIMETER: ±0.1, ANGULAR: ± 0.05° * DOES NOT APPLY TO HOLE SIZE				BANGLADESH RICE RESEARCH INSTITUTE SFMRA PROJECT, FMPHT DIVISION		DO NOT SCALE DRAWING	
DETAILS		NAME	SIGNATURE	DATE	FINISH: NONE		
DRAWN		ENGR. SHAFER JAHAN RHAN	S. J.K	26-AUG-2023	FIRST ISSUED: 02-AUG-2023		
CHK'D	DR. MD. MOSHARRAF HOSSAIN	M. M.H		18-DEC-2023	TITLE: BRRI COMPACT RICE MILL (BRRI RM2023)		
APP'VD	DR. AKM SAIBUL ISLAM	A.S.I		30-DEC-2023	DRG. NAME: PADDY HOPPER CASING RING		
THIRD ANGLE PROJECTION:							
				DWG NO: RM2023_s5-92		MANUFACTURING METHOD: MACHINING, BENDING & WELDING	
NOTE: DEBURR AND BREAK SHARP EDGES ALL BENDS MIN. RADIUS UNLESS SPECIFIED				MATERIAL: Plain Carbon Steel		WEIGHT: 577.81 g	
		SCALE: 1:8		SHEET: 1/40		REVISION: A	

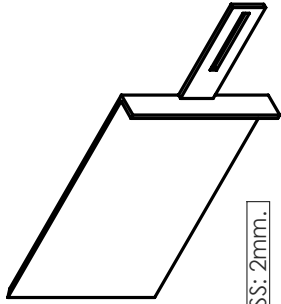

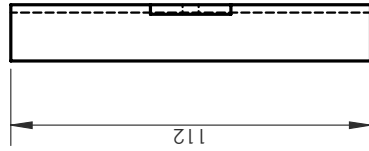
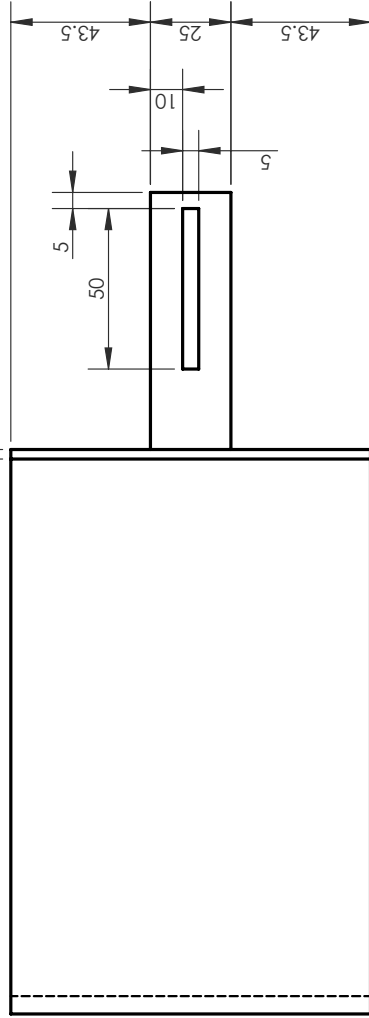
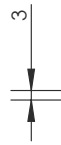
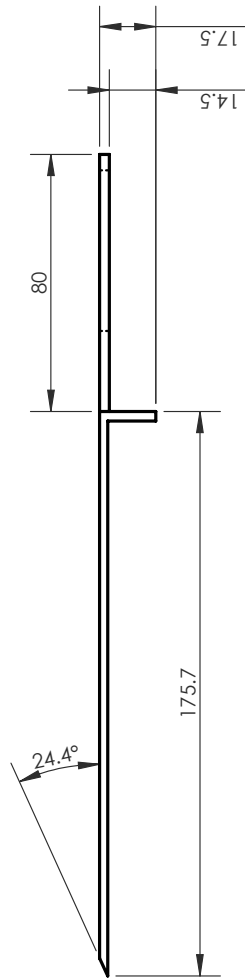

*THICKNESS: 2mm.

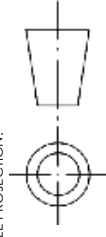

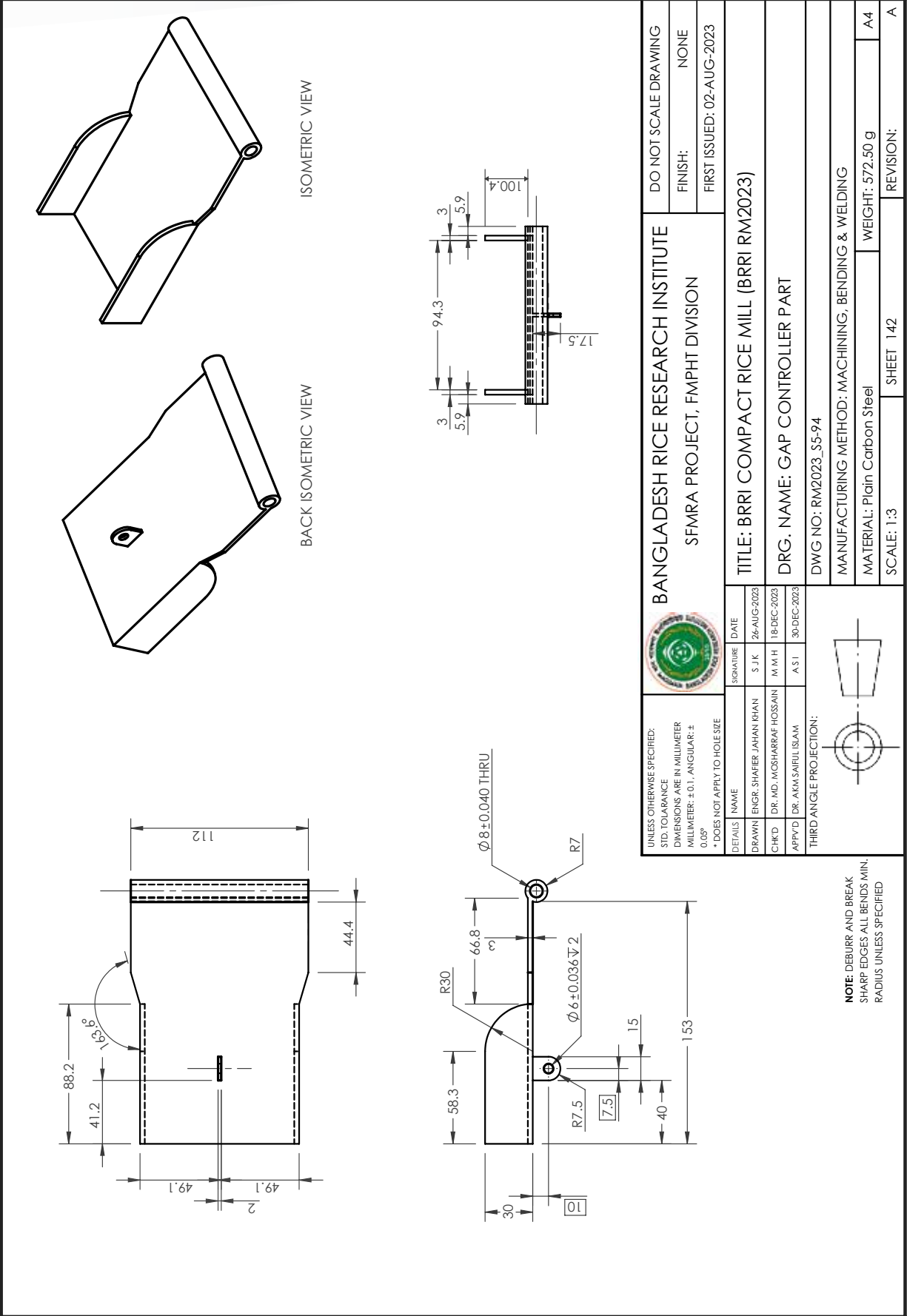
UNLESS OTHERWISE SPECIFIED: STD. TOLERANCE DIMENSIONS ARE IN MILLIMETER MILLIMETER: ±0.1, ANGULAR: ± 0.05° * DOES NOT APPLY TO HOLE SIZE				BANGLADESH RICE RESEARCH INSTITUTE SFMRA PROJECT, FMPHT DIVISION		DO NOT SCALE DRAWING	
DETAILS	NAME	SIGNATURE	DATE	TITLE: BRRI COMPACT RICE MILL (BRRI RM2023)		FINISH: NONE	
DRAWN	ENGR. SHAFER JAHAN RHAN	S J K	26-AUG-2023	DRG. NAME: HOPPER GATE CONTROLLER PART		FIRST ISSUED: 02-AUG-2023	
CHK'D	DR. MD. MOSHARRAF HOSSAIN	M M H	18-DEC-2023	DWG NO: RM2023_s5-93			
APP'VD	DR. AKM SAIBUL ISLAM	A S I	30-DEC-2023	MANUFACTURING METHOD: MACHINING, BENDING & WELDING			
THIRD ANGLE PROJECTION:							
NOTE: DEBURR AND BREAK SHARP EDGES ALL BENDS MIN. RADIUS UNLESS SPECIFIED				MATERIAL: ASTM A36 Steel		WEIGHT: 460.92 g	
				SCALE: 1:2		REVISION: A	
				SHEET 1/41		A	

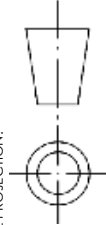

UNLESS OTHERWISE SPECIFIED: STD. TOLERANCE DIMENSIONS ARE IN MILLIMETER MILLIMETER: ±0.1, ANGULAR: ±0.05° * DOES NOT APPLY TO HOLE SIZE				BANGLADESH RICE RESEARCH INSTITUTE SFMRA PROJECT, FMPHT DIVISION		DO NOT SCALE DRAWING	
DETAILS		NAME	SIGNATURE	DATE	FINISH: NONE		
DRAWN		ENGR. SHAFER JAHAN RHAN	S J K	26-AUG-2023	FIRST ISSUED: 02-AUG-2023		
CHK'D		DR. MD. MOSHARRAF HOSSAIN	M M H	18-DEC-2023	TITLE: BRRI COMPACT RICE MILL (BRRI RM2023)		
APP'VD		DR. AKM SAIBUL ISLAM	A S I	30-DEC-2023	DRG. NAME: GAP CONTROLLER PART		
THIRD ANGLE PROJECTION:				DWG NO: RM2023_s5-94			
NOTE: DEBURR AND BREAK SHARP EDGES ALL BENDS MIN. RADIUS UNLESS SPECIFIED				MANUFACTURING METHOD: MACHINING, BENDING & WELDING			
				MATERIAL: Plain Carbon Steel		WEIGHT: 572.50 g	
				SCALE: 1:3		REVISION: A	
				SHEET 142		A	

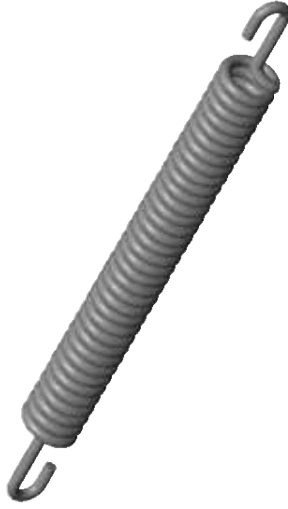

PURCHASE FROM MARKET.
 PITCH: 2.2mm
 REVOLUTION: 37.50

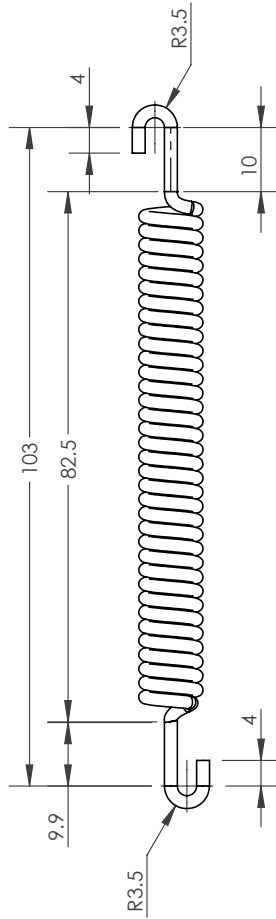

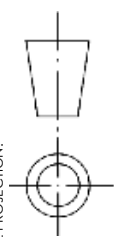
UNLESS OTHERWISE SPECIFIED: STD. TOLERANCE DIMENSIONS ARE IN MILLIMETER MILLIMETER: ±0.1, ANGULAR: ±0.05° * DOES NOT APPLY TO HOLE SIZE				BANGLADESH RICE RESEARCH INSTITUTE SFMRA PROJECT, FMPHT DIVISION		DO NOT SCALE DRAWING	
DETAILS		NAME	SIGNATURE	DATE	FINISH: NONE		
DRAWN		ENGR. SHAFER JAHAN RHAN	S. J.K	26-AUG-2023	FIRST ISSUED: 02-AUG-2023		
CHK'D	DR. MD. MOSHARRAF HOSSAIN	M. M.H	M. M.H	18-DEC-2023	TITLE: BRRI COMPACT RICE MILL (BRRI RM2023)		
APP'VD	DR. AKM SAIBUL ISLAM	A. S.I	A. S.I	30-DEC-2023	DRG. NAME: HOPPER-SPRING		
THIRD ANGLE PROJECTION:				DWG NO: RM2023_55-95			
				MANUFACTURING METHOD: MACHINING, BENDING & WELDING			
NOTE: DEBURR AND BREAK SHARP EDGES ALL BENDS MIN. RADIUS UNLESS SPECIFIED				MATERIAL: Tungsten		WEIGHT: 55.97 g	
SCALE: 1:1				SHEET 143		REVISION: A	

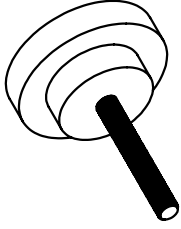

THREAD: MATRIX TAP
M6X1.0

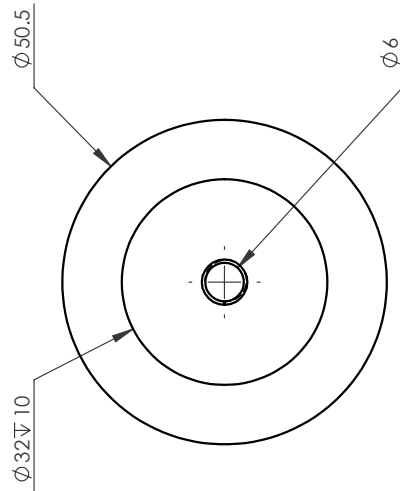
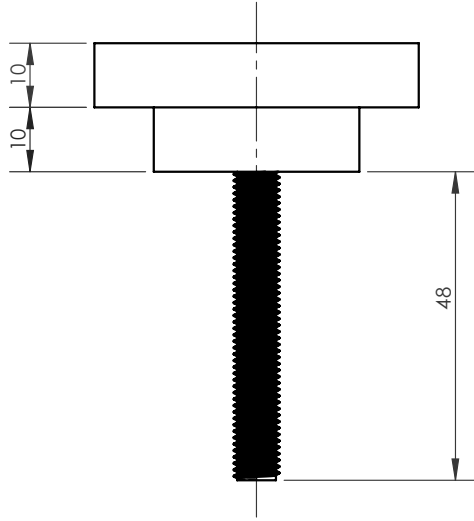

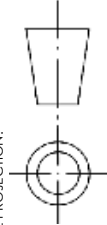
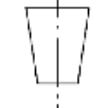
UNLESS OTHERWISE SPECIFIED: STD. TOLERANCE DIMENSIONS ARE IN MILLIMETER MILLIMETER: ± 0.1 , ANGULAR: $\pm 0.05^\circ$ * DOES NOT APPLY TO HOLE SIZE				BANGLADESH RICE RESEARCH INSTITUTE SFMRA PROJECT, FMPHT DIVISION		DO NOT SCALE DRAWING	
DETAILS		NAME	SIGNATURE	DATE	FINISH: NONE		
DRAWN		ENGR. SHAFER JAHAN RHAN	S J K	26-AUG-2023	FIRST ISSUED: 02-AUG-2023		
CHK'D		DR. MD. MOSHARRAF HOSSAIN	M M H	18-DEC-2023	TITLE: BRRI COMPACT RICE MILL (BRRI RM2023)		
APP'VD		DR. AKM SAIBUL ISLAM	A S I	30-DEC-2023	DRG. NAME: THREAD KEY		
THIRD ANGLE PROJECTION:				DWG NO: RM2023_S5-96			
NOTE: DEBURR AND BREAK SHARP EDGES ALL BENDS MIN. RADIUS UNLESS SPECIFIED				MANUFACTURING METHOD: MACHINING, BENDING & WELDING			
		SCALE: 1:1		SHEET: 144		REVISION: A	
		MATERIAL: ASTM A36 Steel		WEIGHT: 232.80 g		A4	

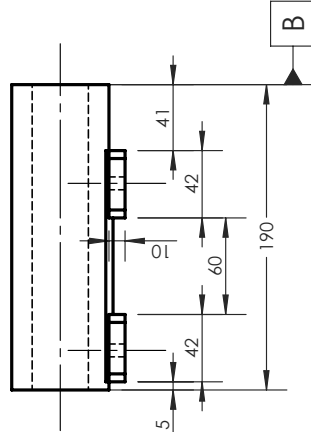
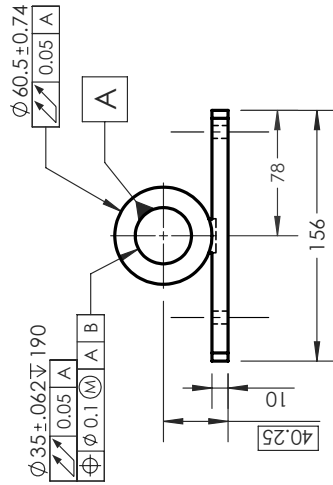
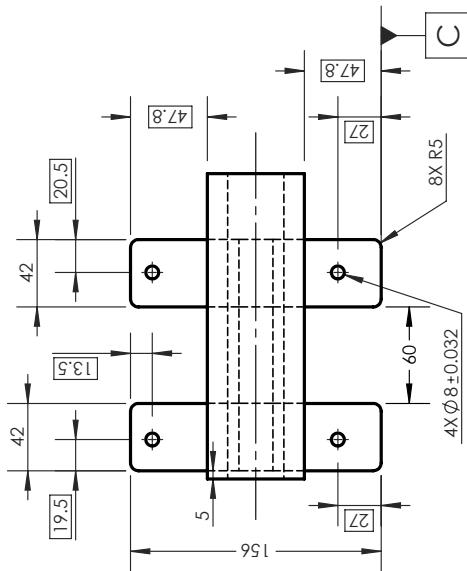
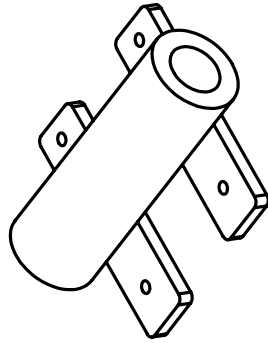

NOTE: DEBURR AND BREAK SHARP EDGES ALL BENDS MIN. RADIUS UNLESS SPECIFIED

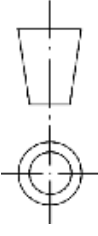
		BANGLADESH RICE RESEARCH INSTITUTE SFMRA PROJECT, FMPHT DIVISION		DO NOT SCALE DRAWING	
UNLESS OTHERWISE SPECIFIED: STD. TOLERANCE DIMENSIONS ARE IN MILLIMETER MILLIMETER: ±0.1, ANGULAR: ±0.05° * DOES NOT APPLY TO HOLE SIZE		DETAILS	NAME	SIGNATURE	DATE
CHK'D	DR. MD. MOSHARRAF HOSSAIN	ENGR. SHAFER JAHAN RHAN	S. J.K	M. M.H	17-AUG-2023
APP'VD	DR. AKM SAIBUL ISLAM		A. S.I	A. S.I	18-DEC-2023
THIRD ANGLE PROJECTION:				DWG NO: RM2023_s5-98 MANUFACTURING METHOD: MACHINING, BENDING & WELDING MATERIAL: ASTM A36 Steel WEIGHT: 3902.67 g SCALE: 1:4 SHEET 146	
				FINISH:	NONE
				FIRST ISSUED:	02-AUG-2023
				TITLE: BRRI COMPACT RICE MILL (BRRI RM2023) DRG. NAME: DELIVERY CONTROLLER SHELL - CASE	
				REVISION: A WEIGHT: 3902.67 g A4	



20X35X9-2RS RUBBER SEALED BALL BEARING 20mm X 35mm X 9mm

BRAND VXB
MATERIAL: CHROME STEEL 52100

BEARING TYPE: BALL BEARING
ITEM: 20X35X9-2RS BALL BEARING

ABOUT: THIS IS HARD TO FIND SIZE 20mm X 35mm X 9mm
DIMENSIONS: 20mm X 35mm X 9mm /METRIC
BEARING INNER DIAMETER: **20mm**
BEARING OUTER DIAMETER: **35mm**

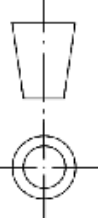
UNLESS OTHERWISE SPECIFIED: STD. TOLERANCE DIMENSIONS ARE IN MILLIMETER MILLIMETER: ±0.1, ANGULAR: ± 0.05° * DOES NOT APPLY TO HOLE SIZE				BANGLADESH RICE RESEARCH INSTITUTE SFMRA PROJECT, FMPHT DIVISION		DO NOT SCALE DRAWING			
DETAILS		NAME	SIGNATURE	DATE	FINISH: NONE				
DRAWN		ENGR. SHAFER JAHAN RHAN	S J K	28-AUG-2023	FIRST ISSUED: 02-AUG-2023				
CHK'D	DR. MD. MOSHARRAF HOSSAIN	M M H	18-DEC-2023	TITLE: BRRI COMPACT RICE MILL (BRRI RM2023)					
APP'D	DR. AKM SAIBUL ISLAM	A S I	30-DEC-2023	DRG. NAME: 20x35x9-2RS Rubber Sealed Ball Bearing					
THIRD ANGLE PROJECTION:				DWG NO: RM2023_s5-99					
				MANUFACTURING METHOD: MACHINING, BENDING & WELDING					
				MATERIAL: Chrome Stainless Steel		WEIGHT: 37.08 g		A4	
				SCALE: 2:2		SHEET: 147		REVISION: A	

NOTE: DEBURR AND BREAK
SHARP EDGES ALL BENDS MIN.
RADIUS UNLESS SPECIFIED

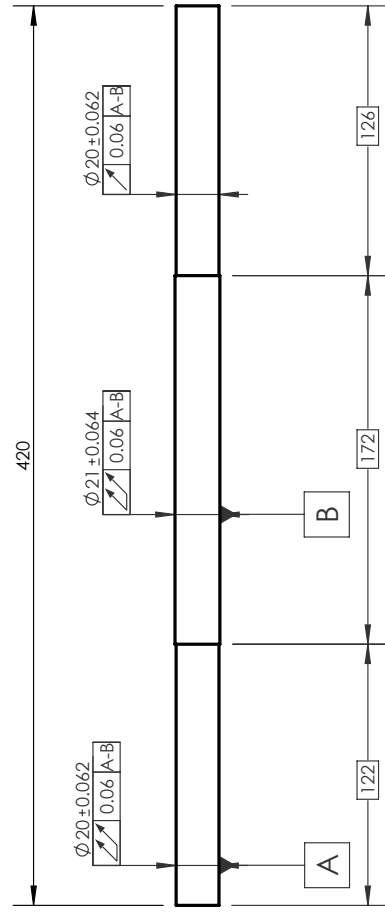
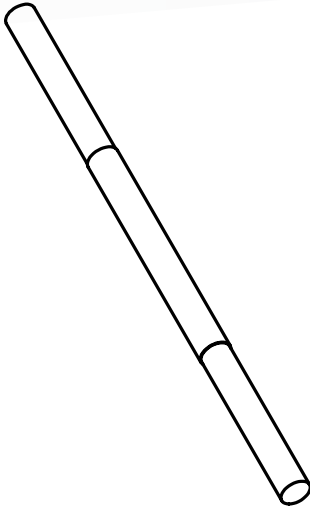

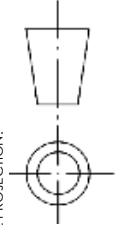

UNLESS OTHERWISE SPECIFIED: STD. TOLERANCE DIMENSIONS ARE IN MILLIMETER MILLIMETER: ± 0.1 , ANGULAR: $\pm 0.05^\circ$ * DOES NOT APPLY TO HOLE SIZE				BANGLADESH RICE RESEARCH INSTITUTE SFMRA PROJECT, FMPHT DIVISION		DO NOT SCALE DRAWING	
DETAILS		NAME	SIGNATURE	DATE	FINISH: NONE		
DRAWN		ENGR. SHAFER JAHAN RHAN	S. J.K	28-AUG-2023	FIRST ISSUED: 02-AUG-2023		
CHK'D		DR. MD. MOSHARRAF HOSSAIN	M. M.H	18-DEC-2023	TITLE: BRRI COMPACT RICE MILL (BRRI RM2023)		
APP'VD		DR. AKM SAIBUL ISLAM	A. S.I	30-DEC-2023	DRG. NAME: DELIVERY CONTROLLER SHELL - SHAFT		
THIRD ANGLE PROJECTION:							
		DWG NO: RM2023_s5-100					
MANUFACTURING METHOD: MACHINING, BENDING & WELDING							
MATERIAL: ASTM A36 Steel		WEIGHT: 1079.26 g		SHEET 148		REVISION: A	
SCALE: 1:2						A	

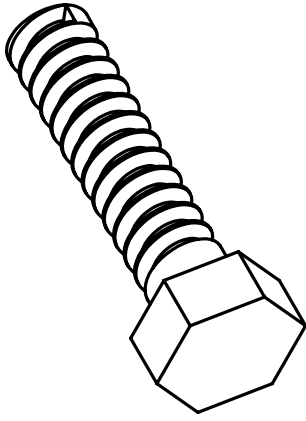
NOTE: DEBURR AND BREAK SHARP EDGES ALL BENDS MIN. RADIUS UNLESS SPECIFIED



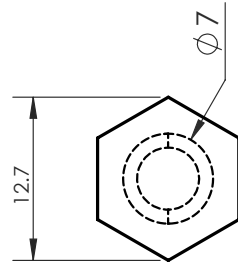
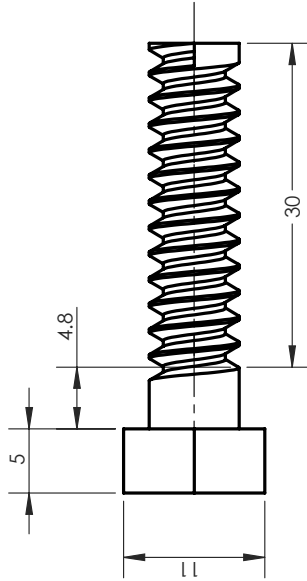

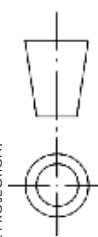

**M7 BOLT LONG 30mm
HOPPER PULLEY TIGHT LOCK BOLT.

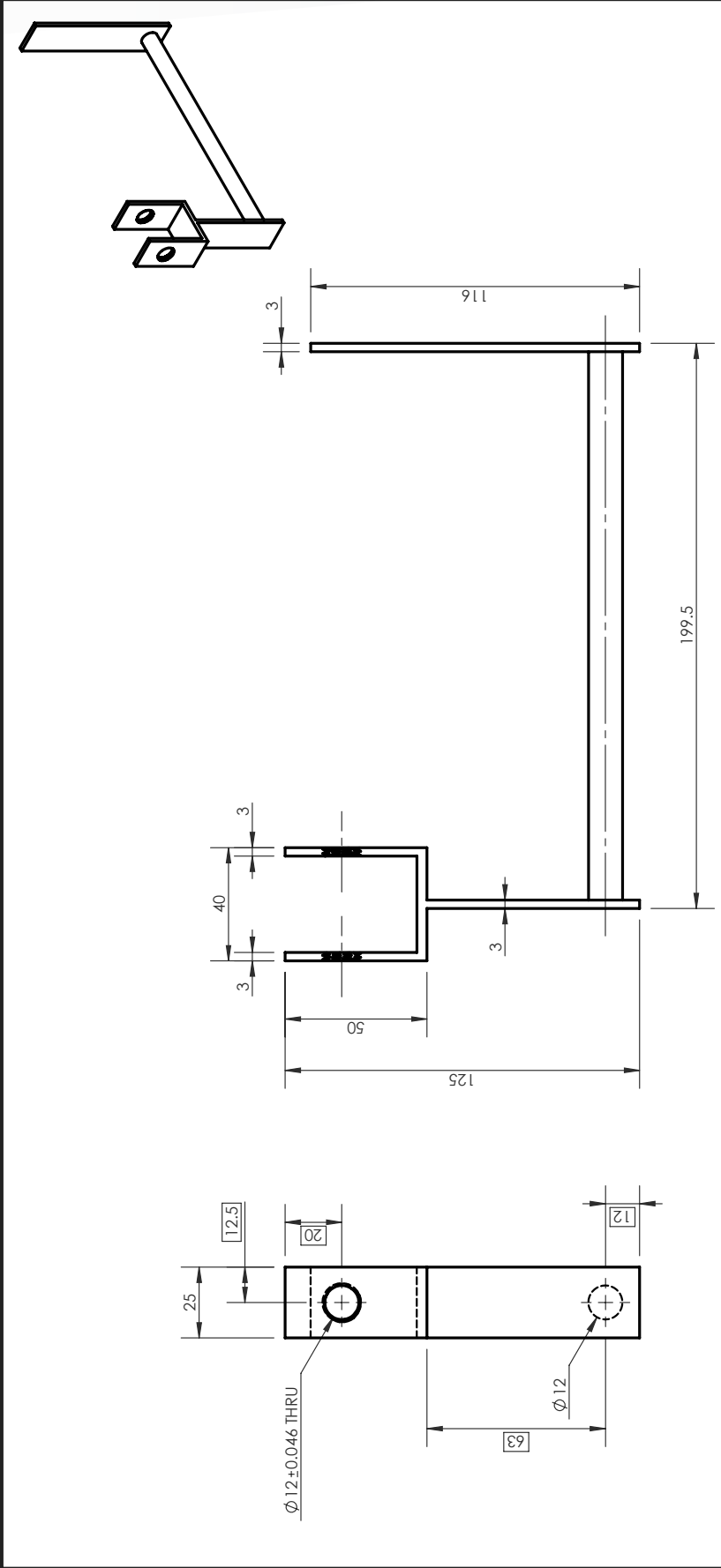

UNLESS OTHERWISE SPECIFIED: STD. TOLERANCE DIMENSIONS ARE IN MILLIMETER MILLIMETER: ±0.1, ANGULAR: ± 0.05° * DOES NOT APPLY TO HOLE SIZE				BANGLADESH RICE RESEARCH INSTITUTE SFMRA PROJECT, FMPHT DIVISION		DO NOT SCALE DRAWING	
DETAILS		NAME	SIGNATURE	DATE	FINISH: NONE		
DRAWN		ENGR. SHAFER JAHAN RHAN	S J K	28-AUG-2023	FIRST ISSUED: 02-AUG-2023		
CHK'D	DR. MD. MOSHARRAF HOSSAIN	M M H		18-DEC-2023	TITLE: BRRI COMPACT RICE MILL (BRRI RM2023)		
APP'VD	DR. AKM SAIBUL ISLAM	A S I		30-DEC-2023	DRG. NAME: M7 BOLT LONG 30mm		
THIRD ANGLE PROJECTION:				DWG NO: RM2023_S5-101			
		MANUFACTURING METHOD: MACHINING, BENDING & WELDING					
		MATERIAL: Stainless Steel (ferritic)		WEIGHT: 10.81 g		A4	
		SCALE: 2:1		SHEET 149		REVISION: A	

NOTE: DEBURR AND BREAK SHARP EDGES ALL BENDS MIN. RADIUS UNLESS SPECIFIED

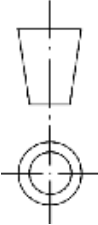

UNLESS OTHERWISE SPECIFIED: STD. TOLERANCE DIMENSIONS ARE IN MILLIMETER MILLIMETER: ±0.1, ANGULAR: ± 0.05° * DOES NOT APPLY TO HOLE SIZE				BANGLADESH RICE RESEARCH INSTITUTE SFMRA PROJECT, FMPHT DIVISION		DO NOT SCALE DRAWING	
DETAILS		NAME	SIGNATURE	DATE	FINISH: NONE		
DRAWN		ENGR. SHAFER JAHAN KHAN	S. J.K	28-AUG-2023	FIRST ISSUED: 02-AUG-2023		
CHK'D		DR. MD. MOSHARRAF HOSSAIN	M. M.H	18-DEC-2023	TITLE: BRRI COMPACT RICE MILL (BRRI RM2023)		
APP'VD		DR. AKM SAIBUL ISLAM	A. S.I	30-DEC-2023	DRG. NAME: M7 BOLT LONG 30mm		
THIRD ANGLE PROJECTION:				DWG NO: RM2023_s5-102			
NOTE: DEBURR AND BREAK SHARP EDGES ALL BENDS MIN. RADIUS UNLESS SPECIFIED				MANUFACTURING METHOD: MACHINING, BENDING & WELDING			
		MATERIAL: Plain Carbon Steel		WEIGHT: 358.58 g		A4	
		SCALE: 1:5		SHEET: 150		REVISION: A	

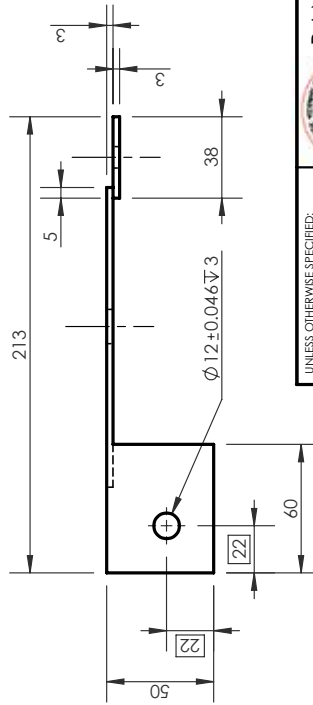
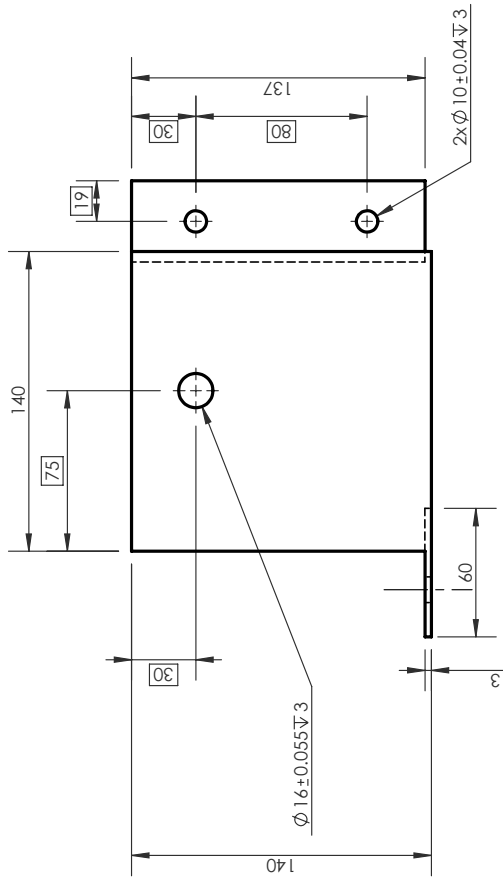
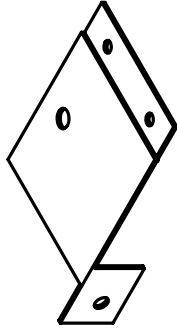

BANGLADESH RICE RESEARCH INSTITUTE
SFMRA PROJECT, FMPHT DIVISION

DO NOT SCALE DRAWING
 FINISH: NONE
 FIRST ISSUED: 02-AUG-2023

TITLE: BRRI COMPACT RICE MILL (BRRI RM2023)

DRG. NAME: M7 BOLT LONG 30mm

DWG NO: RM2023_s5-103

MANUFACTURING METHOD: MACHINING, BENDING & WELDING

MATERIAL: Plain Carbon Steel

WEIGHT: 638.23 g

SCALE: 1:5

SHEET 151

REVISION: A

UNLESS OTHERWISE SPECIFIED:
 STD. TOLERANCE
 DIMENSIONS ARE IN MILLIMETER
 MILLIMETER: ±0.1, ANGULAR: ±
 0.05°
 * DOES NOT APPLY TO HOLE SIZE

DETAILS	NAME	SIGNATURE	DATE
DRAWN	ENGR. SHAFER JAHAN KHAN	S J K	28-AUG-2023
CHK'D	DR. MD. MOSHARRAF HOSSAIN	M M H	18-DEC-2023
APP'D	DR. AKM SAIBUL ISLAM	A S I	30-DEC-2023

THIRD ANGLE PROJECTION:

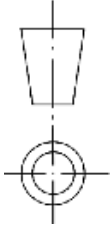

**NOTE: DEBURR AND BREAK
 SHARP EDGES ALL BENDS MIN.
 RADIUS UNLESS SPECIFIED**

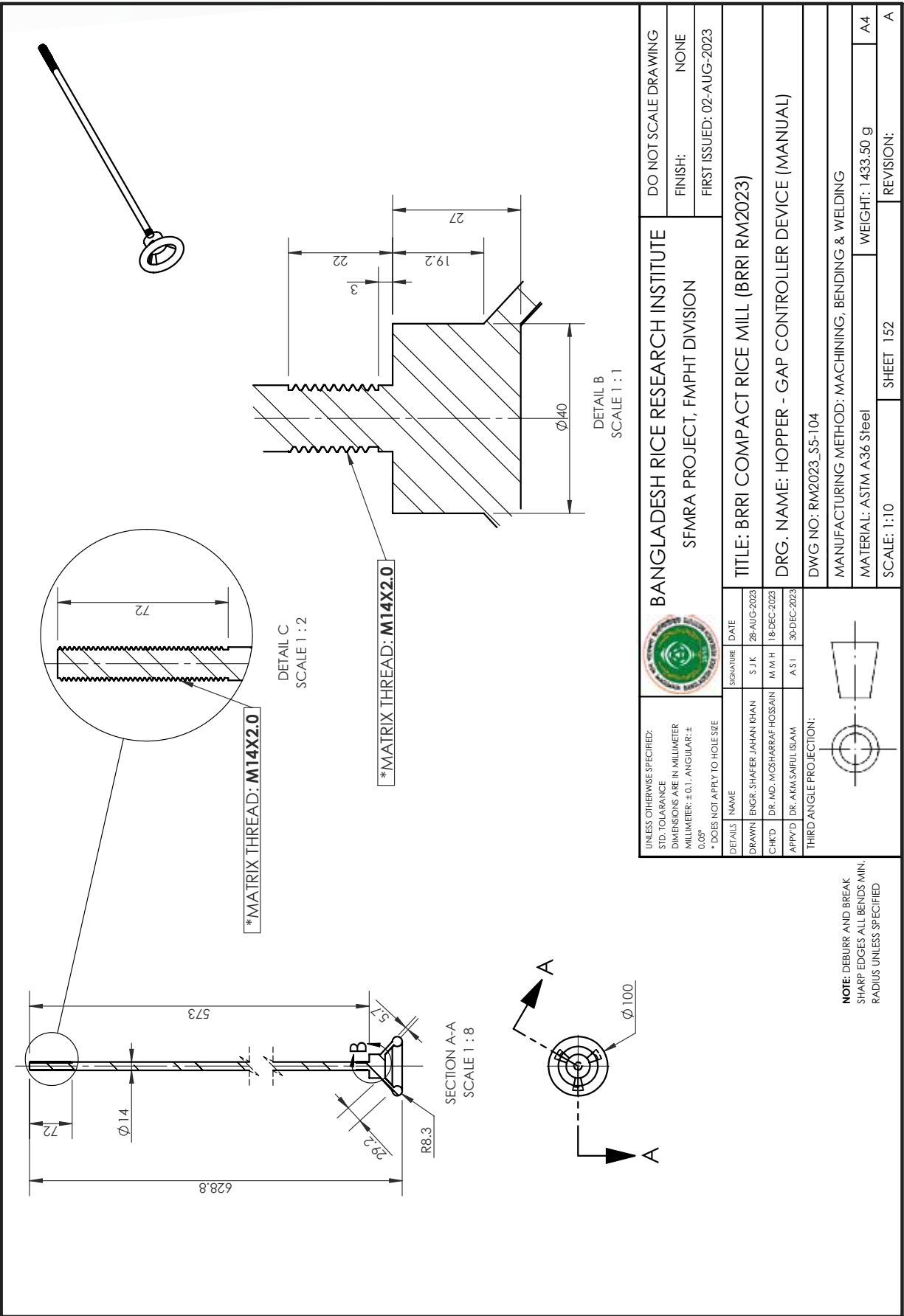

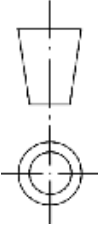
UNLESS OTHERWISE SPECIFIED: STD. TOLERANCE DIMENSIONS ARE IN MILLIMETER MILLIMETER: ±0.1, ANGULAR: ±0.05° * DOES NOT APPLY TO HOLE SIZE				BANGLADESH RICE RESEARCH INSTITUTE SFMRA PROJECT, FMPHT DIVISION		DO NOT SCALE DRAWING	
DETAILS		NAME	SIGNATURE	DATE	FINISH: NONE		FIRST ISSUED: 02-AUG-2023
CHK'D	DR. MD. MOSHARRAF HOSSAIN	M. M. H.	M. M. H.	18-DEC-2023	TITLE: BRRI COMPACT RICE MILL (BRRI RM2023)		
APP'VD	DR. AKM SAIBUL ISLAM	A. S. I.	A. S. I.	30-DEC-2023	DRG. NAME: HOPPER - GAP CONTROLLER DEVICE (MANUAL)		
THIRD ANGLE PROJECTION:						DWG NO: RM2023_s5-104	
NOTE: DEBURR AND BREAK SHARP EDGES ALL BENDS MIN. RADIUS UNLESS SPECIFIED				MANUFACTURING METHOD: MACHINING, BENDING & WELDING		MATERIAL: ASTM A36 Steel	
				SCALE: 1:10		WEIGHT: 1433.50 g	
				SHEET 1/52		REVISION: A	

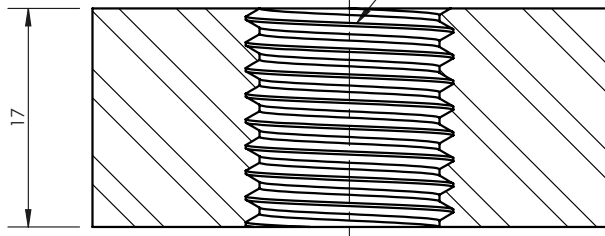
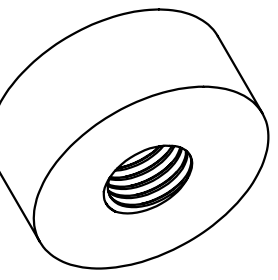
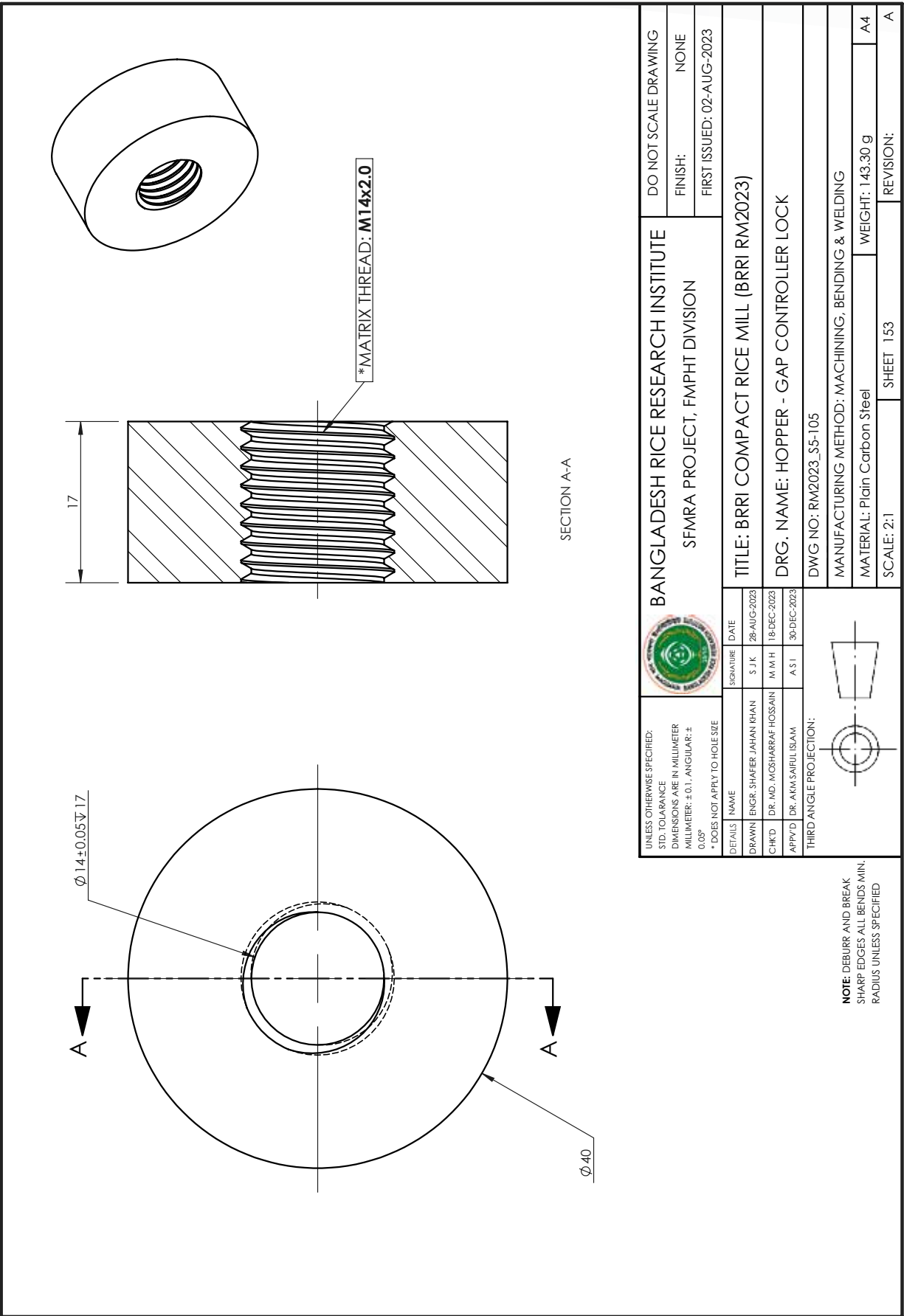

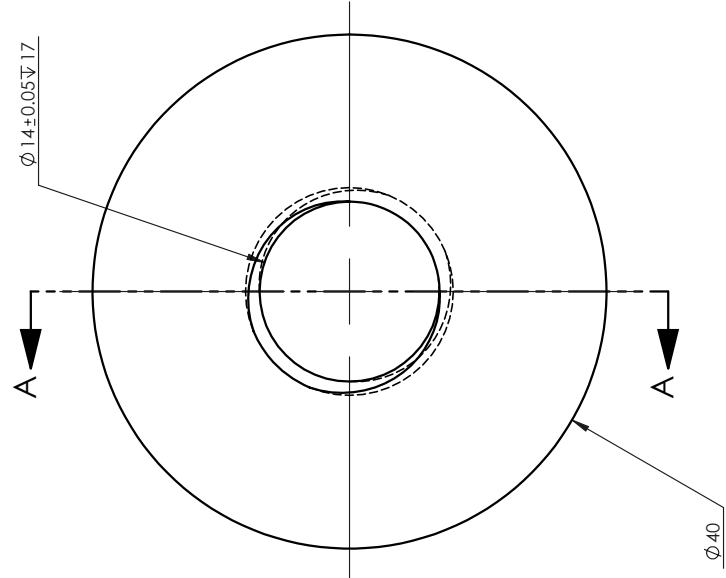

SECTION A-A

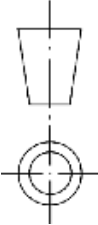

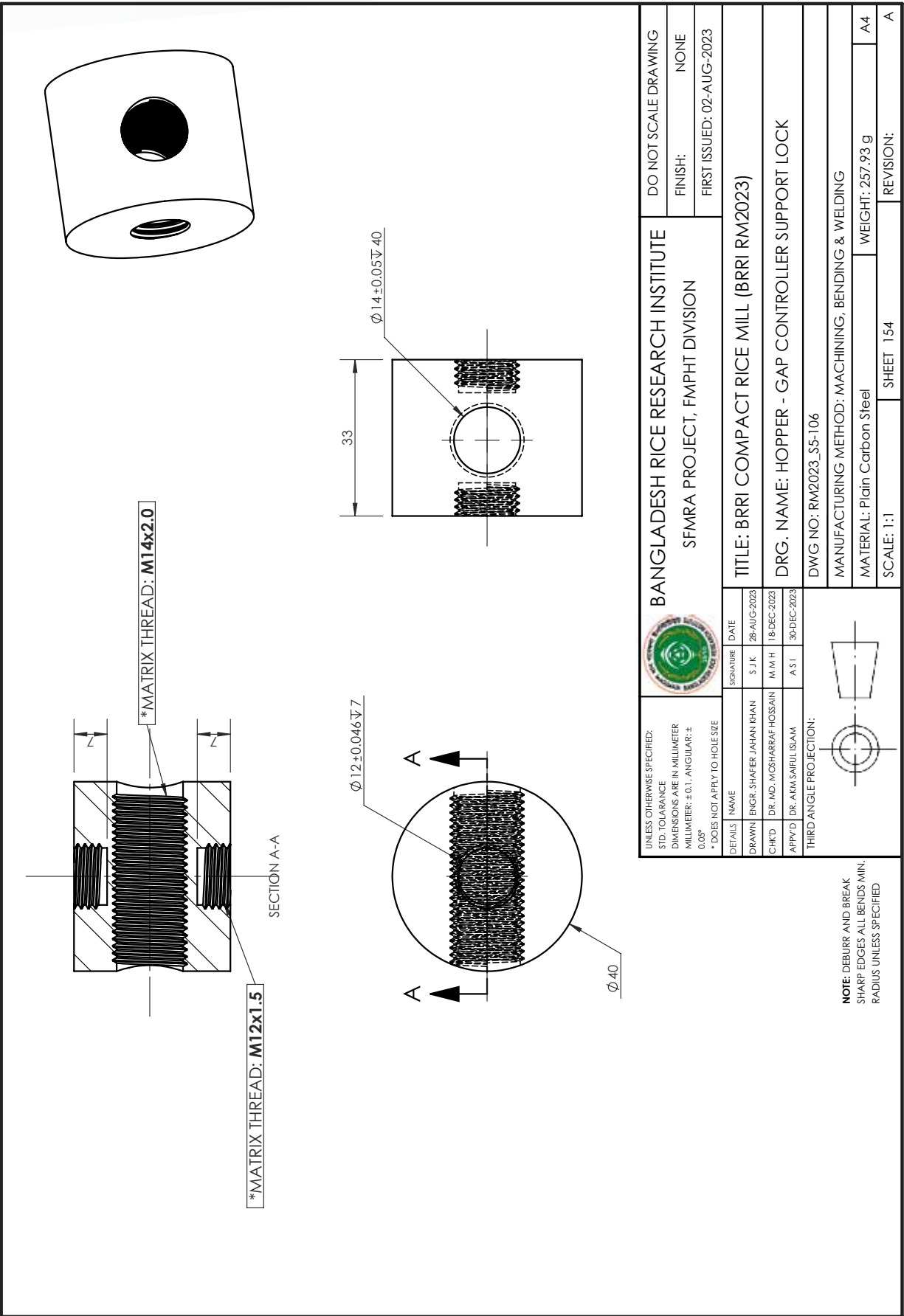

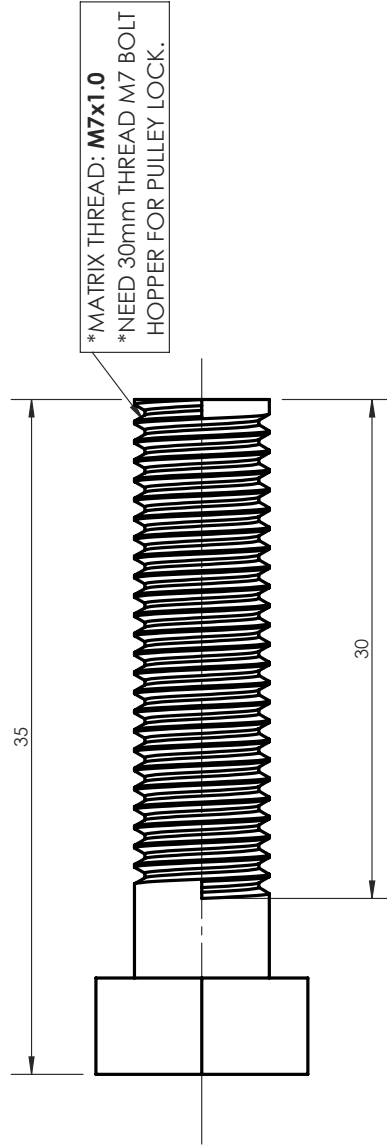
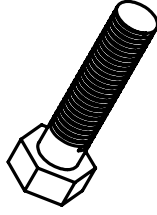
UNLESS OTHERWISE SPECIFIED: STD. TOLERANCE DIMENSIONS ARE IN MILLIMETER MILLIMETER: ± 0.1 , ANGULAR: $\pm 0.05^\circ$ * DOES NOT APPLY TO HOLE SIZE				BANGLADESH RICE RESEARCH INSTITUTE SFMRA PROJECT, FMPHT DIVISION		DO NOT SCALE DRAWING	
DETAILS		NAME	SIGNATURE	DATE	FINISH: NONE		
DRAWN		ENGR. SHAFER JAHAN KHAN	S. J.K	28-AUG-2023	FIRST ISSUED: 02-AUG-2023		
CHK'D	DR. MD. MOSHARRAF HOSSAIN	M. M.H	M. M.H	18-DEC-2023	TITLE: BRRI COMPACT RICE MILL (BRRI RM2023)		
APP'VD	DR. AKM SAIFUL ISLAM	A. S.I	A. S.I	30-DEC-2023	DRG. NAME: HOPPER - GAP CONTROLLER LOCK		
THIRD ANGLE PROJECTION:						DWG NO: RM2023_s5-105	
NOTE: DEBURR AND BREAK SHARP EDGES ALL BENDS MIN. RADIUS UNLESS SPECIFIED				MANUFACTURING METHOD: MACHINING, BENDING & WELDING		MATERIAL: Plain Carbon Steel	
				SCALE: 2:1		REVISION: A	
				SHEET 153		WEIGHT: 143.30 g	



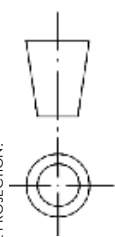

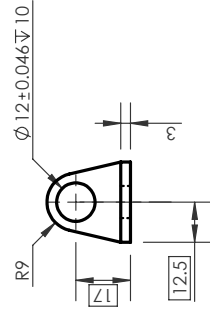
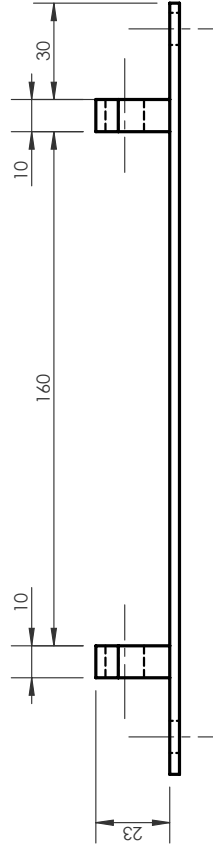
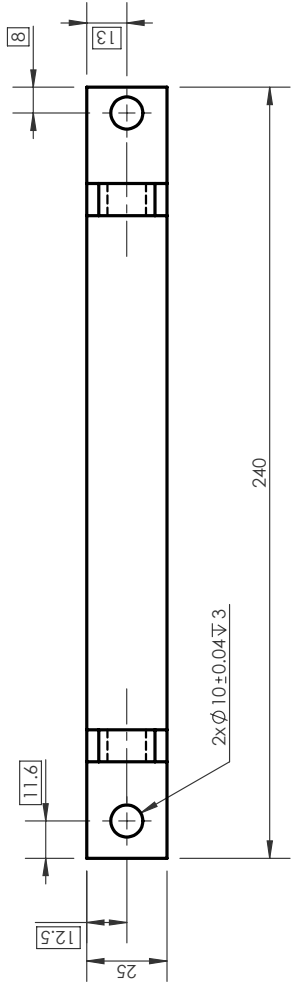
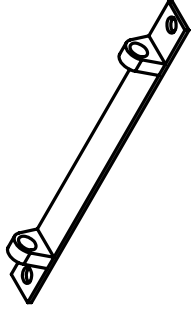
UNLESS OTHERWISE SPECIFIED: STD. TOLERANCE DIMENSIONS ARE IN MILLIMETER MILLIMETER: ±0.1, ANGULAR: ±0.5° * DOES NOT APPLY TO HOLE SIZE				BANGLADESH RICE RESEARCH INSTITUTE SFMRA PROJECT, FMPHT DIVISION		DO NOT SCALE DRAWING	
DETAILS		NAME	SIGNATURE	DATE	FINISH: NONE		
DRAWN		ENGR. SHAFER JAHAN RHAN	S. J.K	17-AUG-2023	FIRST ISSUED: 02-AUG-2023		
CHK'D	DR. MD. MOSHARRAF HOSSAIN	M. M. H		18-DEC-2023	TITLE: BRRI COMPACT RICE MILL (BRRI RM2023)		
APP'D	DR. AKM SAIFUL ISLAM	A. S. I		30-DEC-2023	DRG. NAME: M7 BOLT LONG 30mm		
THIRD ANGLE PROJECTION:				DWG NO: RM2023_s5-107			
		MANUFACTURING METHOD: MACHINING, BENDING & WELDING					
NOTE: DEBURR AND BREAK SHARP EDGES ALL BENDS MIN. RADIUS UNLESS SPECIFIED		MATERIAL: Stainless Steel (ferritic)		WEIGHT: 11.87 g		A4	
SCALE: 2:1		SHEET: 155		REVISION:		A	

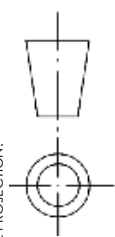

UNLESS OTHERWISE SPECIFIED: STD. TOLERANCE DIMENSIONS ARE IN MILLIMETER MILLIMETER: ±0.1, ANGULAR: ± 0.05° * DOES NOT APPLY TO HOLE SIZE				BANGLADESH RICE RESEARCH INSTITUTE SFMRA PROJECT, FMPHT DIVISION		DO NOT SCALE DRAWING	
DETAILS		NAME	SIGNATURE	DATE	FINISH: NONE		
DRAWN		ENGR. SHAFER JAHAN RHAN	S J K	17-AUG-2023	FIRST ISSUED: 02-AUG-2023		
CHK'D	DR. MD. MOSHARRAF HOSSAIN	M M H		18-DEC-2023	TITLE: BRRI COMPACT RICE MILL (BRRI RM2023)		
APP'D	DR. AKM SAIBUL ISLAM	A S I		30-DEC-2023	DRG. NAME: HOPPER - GAP CONTROLLER BASE SUPPORT		
THIRD ANGLE PROJECTION:							
		DWG NO: RM2023_s5-108					
MANUFACTURING METHOD: MACHINING, BENDING & WELDING							
MATERIAL: Plain Carbon Steel				WEIGHT: 186.46 g		REVISION: A	
SCALE: 1:2				SHEET 156		A	

NOTE: DEBURR AND BREAK SHARP EDGES ALL BENDS MIN. RADIUS UNLESS SPECIFIED