

ABSTRACT

Conventional rice breeding reached at an exhaustive state leading lower genetic gain in most rice breeding program globally. Modern rice breeding approaches made a profound impact on breaking yield ceiling in rice. The major paradigm shift in breeding got the momentum over the last two decades since the availability of high throughput molecular marker technology which enables reducing the genotyping cost immensely. Genomic selection is now considering as a novel alternative to traditional marker assisted selection (MAS) for quantitative traits. Such low cost genotyping and selecting better individuals through rapid generation advance (RGA) substantially able to cut the plant breeding cycle 2-3 fold. IRRI is focusing its breeding program using these modern technologies and data driven breeding decision support tools to accelerate genetic gain in rice. In Bangladesh, total 769 advance breeding lines were evaluated at four agro-environments e.g. Satkhira, Rangpur, Mymensingh and Cumilla in 2018 season wet (T. Aman season) to identify superior progenies (having higher breeding values, BVs) with superior agronomic performance. The trials were established with partially replicated (P-rep) design and the plot size was 5.4 sqm for each entry. Results revealed that based on BLUP analysis the predicted mean yield ranged from 3.58 to 4.93 t/ha (Fig-2). Growth duration of the tested lines were observed between 110 to 130 days. Estimated breeding values (EBVs) were calculated for all the entries using pedigree-BLUP model in R. It was recorded that the EBVs of the tested entries ranged from -1.685 to 1.991 t/ha. Based on the EBVs all the entries were ranked and the top 10 entries (Fig-3) were selected for next generation breeding cycle. Selection of best entries and inter-cross among them would lead to yield increase in each generation resulting genetic gain after each cycle. Thus yield ceiling barriers in rice might be breakdown sustainable and persistently.

INTRODUCTION

- ✓ After the green revolution with IR8 in 1960 genetic gain in rice has not been accelerated yet significantly
- ✓ The primary mission of rice breeding is to develop high yield varieties to improve production to meet the global food demand (Xu et al. 2014)
- ✓ The most crucial factors which considered limiting the lower genetic gain are the longer breeding cycle and inefficient breeding technique for example pedigree breeding method
- ✓ Rapid generation advance (RGA) in rice breeding would substantially cut breeding cycle by 3-4 years (Fig-1) consequently enhancing genetic gains at faster rate per unit time
- ✓ Modern rice breeding approaches made a profound impact on breaking yield ceiling and bottleneck the genetic gain barriers in many crops
- ✓ The availability of molecular technology expedite the potential in genomic selection (GS) which would lead and reshape the cost effective and efficient breeding techniques
- ✓ GS is now considering as a novel alternative to traditional marker assisted selection (MAS) for quantitative traits (Hickey et al. 2017).

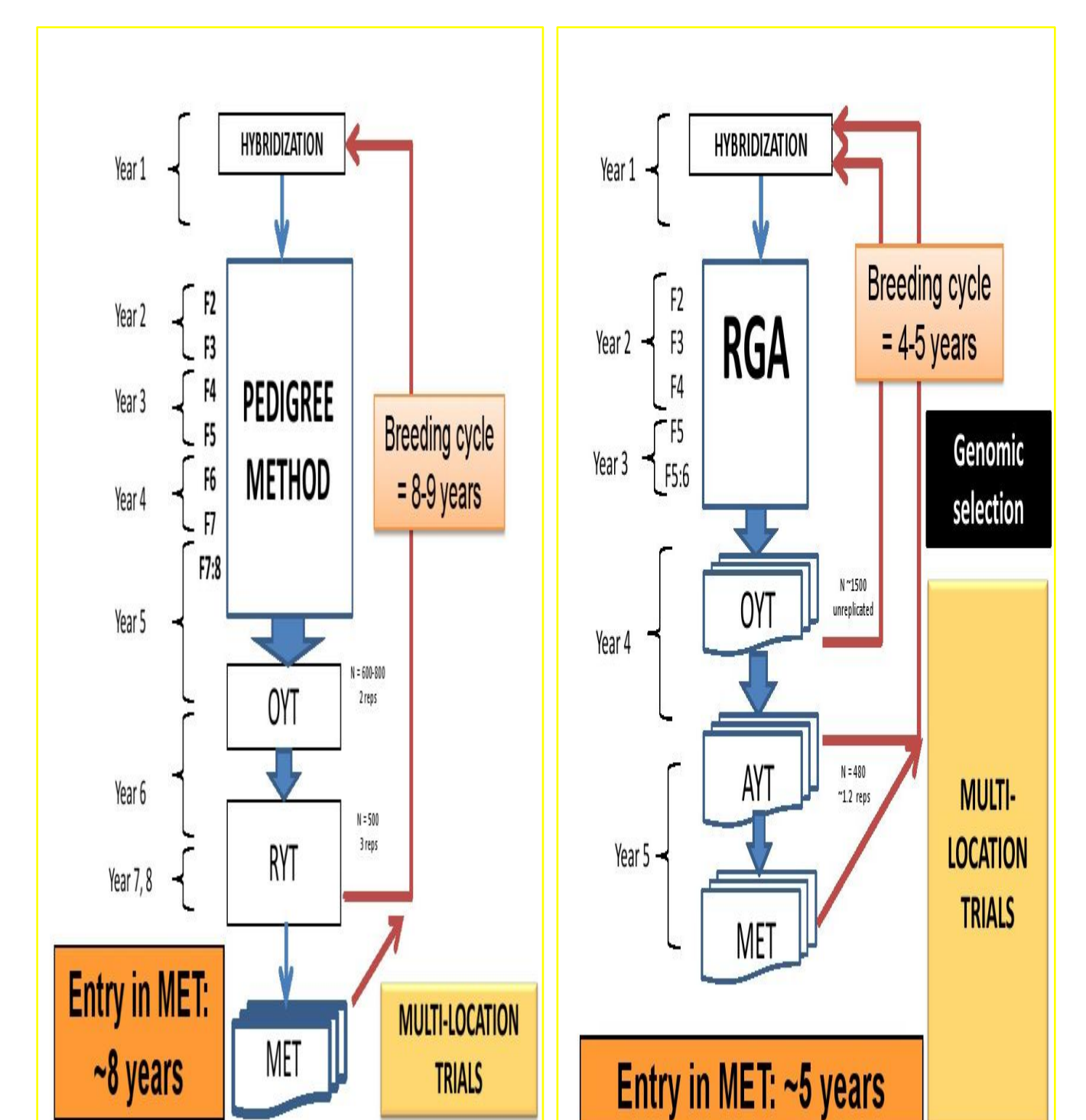

Fig-1: Comparison of pedigree and RGA (SSD) breeding cycle

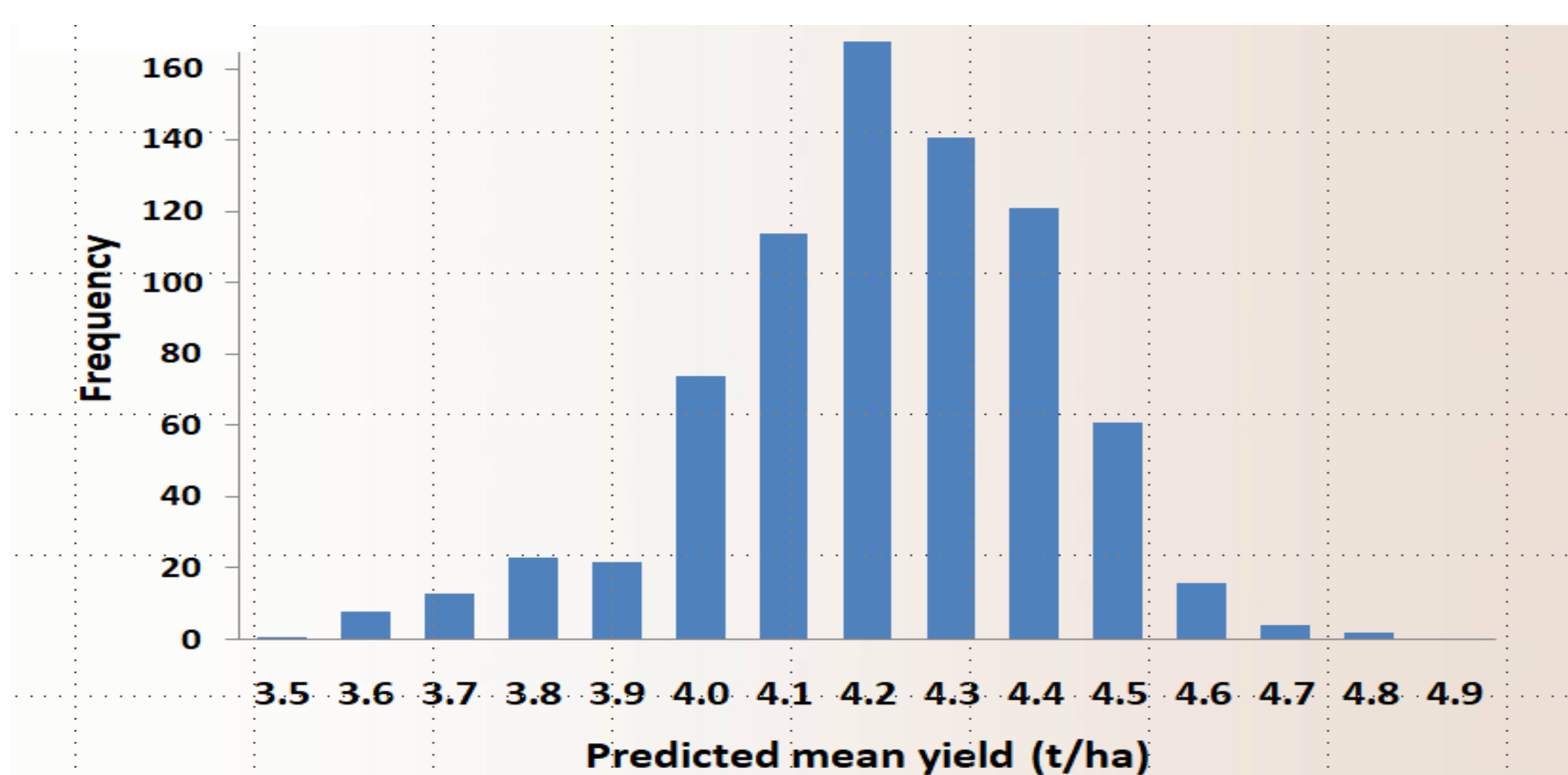

Fig-2: Frequency distribution of yield performances of 769 breeding lines

MATERIAL AND METHODS

- ✓ A total of 769 advance breeding lines were used to evaluate performances at four environments e.g. Satkhira, Rangpur, Mymensingh and Cumilla in Bangladesh in 2018 season wet (T. Aman season)
- ✓ Partially replicated (P-rep) incomplete design was used to design and layout the experiment
- ✓ The plot size (for each entry) was 5.4 sqm with 20 x 20 cm plant to plant and row to row spacing
- ✓ BLUP method was used to calculate predicted means
- ✓ Pedigree-BLUP was used to estimate estimated breeding values (EBVs)

RESULTS AND DISCUSSION

- ✓ The predicted means ranged from 3.58 to 4.93 t/ha (Fig-2)
- ✓ Growth duration of the tested lines were observed in between 110 to 130 days
- ✓ EBVs of the tested entries ranged from -1.685 to 1.991 t/ha (Figure-3)
- ✓ Based on EBV and predicted means top ranked 10 entries (Fig-3) were selected for next generation breeding cycles
- ✓ The population mean of predicted yield in the subsequent generations would be increased in shorter time and less cost by using best x best crossing strategies followed by RGA techniques
- ✓ GS provides opportunities to increase genetic gain of complex traits per unit time and cost (Bhat et al, 2016)

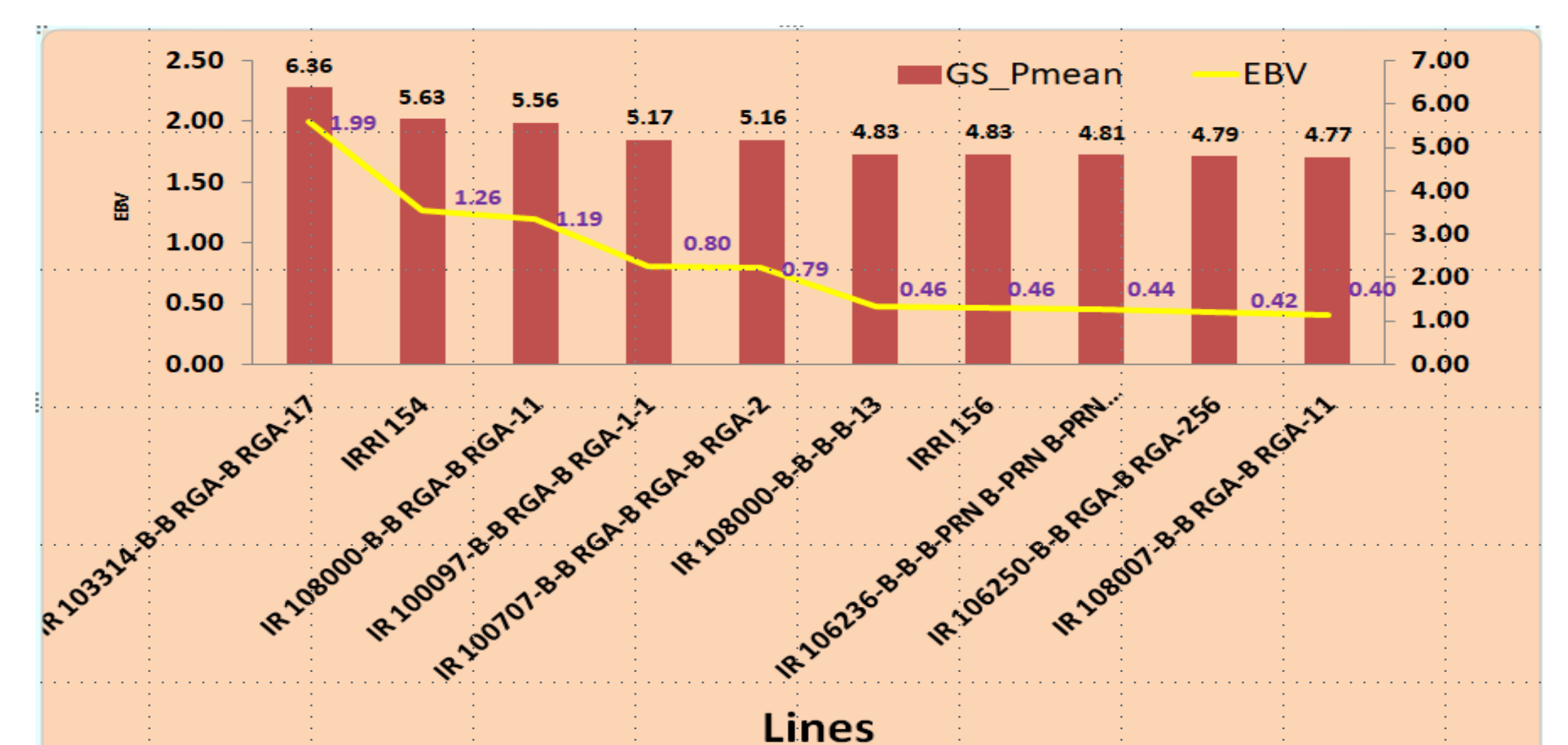

Fig-3: Estimated breeding values (EBV) and GS based predicted means of best 10 entries

CONCLUSION

- ✓ Genomic selection is a powerful tools used in parental selection to initiate breeding cycles for advancement of genetic gain in quantitative traits
- ✓ Selection of top ranked entries with highest EBV/ GEBV could be an excellent parental selection for next generation breeding cycle
- ✓ Inter-cross the selected top ranked parents and recycle them in the next breeding cycle and advance progenies generation through RGA would substantially increase genetic gain at faster rate sustainably thus yield ceiling might be breakdown significantly

ACKNOWLEDGEMENT

- ✓ This work was conducted under IRRI-TRB project funded by BMGF

REFERENCE

- ✓ Bhat J A, Ali S, Salgotra RK, Mir ZA, Dutta S, Jadon V, Tyagi A, Mushtaq M, Jain N, Singh PK, Singh GP and Prabhu KV (2016) Genomic Selection in the Era of Next Generation Sequencing for Complex Traits in Plant Breeding. Front. Genet. 7:221.
- ✓ Hickey JM, Chiurugwi T, Mackay I, Powell W, Implementing Genomic Selection in CBPWP (2017) Genomic prediction unifies animal and plant breeding programs to form platforms for biological discovery. Nat Genet 49:1297–1303.
- ✓ Xu S, Zhu D, Zhang Q (2014) Predicting hybrid performance in rice using genomic best linear unbiased prediction. Proc Natl Acad Sci U S A 111: 12456–12461.