

Designing the BRRI Rice-Wheat Thresher (Model: BRRI TH2023)



Designing the BRRI Rice-Wheat Thresher (Model: BRRI TH2023)

AKM Saiful Islam

AKM Saiful Islam



Bangladesh Rice Research Institute

Designing the BRRI Rice-Wheat Thresher (Model: BRRI TH2023)



AKM Saiful Islam

First published : July 2024

Publication no. : 420

Number of copies : 300

Copyright : **Bangladesh Rice Research Institute**

Cover page design : **Dr. AKM Saiful Islam**

Communication : Publication and Public Relation Division
Bangladesh Rice Research Institute
Gazipur, Bangladesh

Printed by : **Aranna Printing & Packaging**
218, Fakirapool, Dhaka-1000
Cell : 01715863819

Engineering drawing

Drawn by : **Shafier Jahan Khan**
Mechanical Engineer, B.Sc. (Hons.)
Research Assistant, SFMRA project
Bangladesh Rice Research Institute (BRRI)

Checked by : **Professor Dr. Md. Mosharraf Hossain**
Department of Farm Power and Machinery
Bangladesh Agricultural University, Mymensingh

Approved by : **Dr. AKM Saiful Islam**
Chief Scientific Officer
Farm Machinery and Postharvest Technology Division
Bangladesh Rice Research Institute, Gazipur

Citation :

Islam, AKM Saiful 2024: Designing the BRRI Rice-Wheat Thresher (Model: BRRI TH2023).
Publication number 420. Bangladesh Rice Research Institute, Gazipur, Bangladesh

Acknowledgment:

Special thanks to Prashad Engineering, Cox's Bazar and all those who directly and indirectly helped in the preparation of this book.

Preface

Engineering drawing is a fundamental aspect of any technological endeavor and plays a pivotal role in designing and developing machinery that can revolutionize farming practices. The BRRRI rice-wheat thresher is an impressive piece of agricultural machinery, with its capability to thresh multiple types of crops efficiently. The incorporation of a good cleaning mechanism is crucial for maintaining grain quality and reducing post-harvest losses. Attaching the flywheel opposite to the engine side is a smart engineering solution to minimize clogging, ensuring smoother operation and increasing the threshing capacity. Reducing the frequency of parts failure is a significant advantage, as it not only lowers maintenance costs but also minimizes downtime during peak harvesting seasons. This book, " Technical Blueprints: Designing the BRRRI Rice-Wheat Thresher (Model: BRRRI TH2023)," is a testament to the ingenuity and dedication of the Bangladesh Rice Research Institute (BRRRI) in advancing agricultural technologies. Within these pages, readers will find detailed engineering drawings, schematics, and technical specifications that elucidate every aspect of the BRRRI Rice-Wheat Thresher. Furthermore, this book offers practical guidance on assembly, maintenance, and troubleshooting, empowering farmers, engineers, and agricultural enthusiasts to harness the full potential of the BRRRI Rice-Wheat Thresher. It is our hope that this book will inspire further advancements in agricultural machinery design.



Director General
Bangladesh Rice Research Institute

Foreword

Threshing, the process of separating grains from harvested crops, is a critical step in agricultural production, particularly in regions where rice and wheat are staple crops. The agricultural sector plays a pivotal role in ensuring food security and sustainable development, particularly in regions where rice and wheat cultivation are integral to livelihoods. However, the inefficiencies and labor-intensive nature of traditional threshing methods often hinder farmers' productivity and profitability. Dr. AKM Saiful Islam and his team have developed BRRRI Rice-Wheat Thresher for threshing multiple crops. It is with great pleasure to introduce "Technical Blueprints: Designing the BRRRI Rice-Wheat Thresher (Model: BRRRI TH2023)," compiled by Dr. AKM Saiful Islam. This comprehensive guide offers a detailed exploration of the design, construction, and operation of the BRRRI Rice-Wheat Thresher. This book provides a comprehensive overview of the inner workings of the Thresher. From the integration of a flywheel in the rotor to mitigate clogging tendencies to the incorporation of robust bearings in the vibrating sieve for enhanced durability, each component is meticulously depicted and explained, offering invaluable insights into the machine's functionality. Moreover, this book serves as a practical resource for individuals involved in agricultural engineering, providing guidance on assembly, maintenance, and troubleshooting of the BRRRI Rice-Wheat Thresher. I commend Dr. AKM Saiful Islam for his dedication to advancing agricultural mechanization and for his invaluable contribution to the field. May this compilation serve as a catalyst for continued progress and prosperity in agricultural communities around the world.

A handwritten signature in blue ink, consisting of stylized cursive letters that appear to read 'S.K.' or similar initials.

(Dr. Md. Shahjahan Kabir)



Chief Scientific Officer
Farm Machinery and Postharvest Technology Division
BIRRI, Gazipur

About Project Director

Dr. AKM Saiful Islam graduated from the Department of Farm Power and Machinery, Bangladesh Agricultural University, Mymensingh and received chancellor award for achieving first position in graduate course. Dr Islam obtained MS degree from the same university in 1996. He completed a postgraduate diploma course from Silsoe College, UK in 1997. DR Islam obtained PhD in Agricultural Engineering from the Department of Farm Power and Machinery, Bangladesh Agricultural University, Mymensingh in 2012. He started his career as a Scientific Officer in Farm Machinery and Postharvest Technology Division of Bangladesh Rice Research Institute in 1998. Dr. Islam developed training manual for seedling raising techniques, BIRRI weeder, rice-wheat reaper, BIRRI open drum thresher, BIRRI rice-wheat thresher, BIRRI panicle thresher, BIRRI whole feed combine harvester. He is involved in the invention and development of mechanized seedling raising techniques, BIRRI seed sower, BIRRI auto seed sower, BIRRI rice transplanter, BIRRI semi automatic rice transplanter, BIRRI solar light trap, BIRRI urea super granular fertilizer, BIRRI power weeder, BIRRI rice-wheat reaper, BIRRI rice-wheat thresher, BIRRI panicle thresher, BIRRI whole feed combine harvester, BIRRI head feed combine harvester, BIRRI straw rope maker, BIRRI air blow rice mill, BIRRI compact rice mill, BIRRI mini rice huller and BIRRI short and long rice processing technology. At present, he is working as a Chief Scientific Officer and project director of the project "Strengthening Farm Machinery Research Activity for Mechanized Rice Cultivation (SFMRA)".

About project

The project "Strengthening Machinery Research Activity for Mechanized Rice Cultivation" was approved for implementation from July 2019 to June 2025 at an estimated cost of Tk 4400 Lakhs. The project is being implemented by the Farm Machinery and Postharvest Technology Division of Bangladesh Rice Research Institute under the Ministry of Agriculture in 12 upazilas of 12 districts of seven divisions of the country. One of the main objectives of the project is to strengthen farm machinery research activities for sustainable rice cultivation. The specific objectives of the project are (a) Developing nine agricultural machinery and technologies suitable to the socio-economic condition of the farmers: i.e. rice transplanter, mini combine harvester, power weeder, reaper binder, compact rice mills, rice transplanter-cum-fertilizer, straw rope maker, seed sower machines, post-harvest management and renewable energy (solar and briquette machines); (b) Further development of the machinery by collecting feedback from the stakeholder through 324 adaptive trials; (c) Providing hands-on training to 6480 machine operators, farmers, mechanics and service providers and 200 local agricultural machinery manufacturers and extension officers/workers to increase their skills on modern agricultural machinery; (d) Capacity building of 20 scientists and 20 workshop workers for the research on modern agricultural machinery through higher education and training; and (e) Modernization of existing farm machinery research lab-cum-workshop. The project activities are a) Developing nine agricultural machinery and post-harvest technologies suitable for sustainable rice production i.e. rice transplanter, combine harvester, power weeder, reaper binder, compact rice mill, rice transplanter-cum-fertilizer, straw rope maker, seed sower machine, post-harvest management and renewable energy (solar and briquette machines); b) To procure prototypes from abroad and preparing indigenously adapted machines through reverse engineering and applied research; c) To develop machine according to the feedback obtained through practical field tests; d) To Conduct 324 two-day residential hands-on training on seedling raising techniques, operation, repair and maintenance of rice transplanters for mechanized rice transplanting; e) To sensitize 6480 farmers, machine operators, mechanics, farmer groups/farmers associations, service providers about utility of agricultural machinery, operating techniques, repair and maintenance through 324 practical field tests of BRRI developed modern machinery; f) To publish the training schedule and names of the trainees in the form of a database on the BRRI web site to maintain transparency and accountability in the training program and to avoid duplicity in the selection of trainees; g) Developing 10 skilled scientific manpower through three months of overseas training; h) To organize short term (7-10 days) training of 10 scientists in agricultural machinery manufacturing countries; j) Conducting 10 trainings of three days duration on transfer of machinery technology to the farm machinery manufacturers/extension officers/workers; j) To enhance quality research skills by establishing machine testing lab (375 square meters) with modern equipment for machinery quality control; k) Develop a commercial approach to agriculture through limited long-term use of farm machinery and rental machinery service providers in the project area; l) Building co-operation between researchers, extension workers, manufacturers and farmers; d) Development of 2,500 cubic meter research field/plot for head office research; d) Vertical extension (450 square meters) of farm machinery lab cum office building at head office; n) Construction of machinery display cum ware house (150 sq m to 750 sq m in 5 Regional stations) for display room at BRRI Regional stations; (v) Skilling of 20 workshop workers through training in machine prototyping, repair and maintenance; d) To provide necessary technical assistance to the entrepreneurs and machinery manufacturing institutions/factories serving through the Department of Agriculture Extension for ensuring the use of sustainable agricultural machinery at the field level. Recruiting 11 persons (one office assistant cum computer programmer, two bench mechanics, two lathe-operators, two tin smiths, two hammer men and two drivers) through outsourcing to support the project director in project execution. Scientists of FMPHT division, research assistants, Accountant of Accounts division and staff of Planning and Evaluation Division are working on the project as additional responsibilities.

Design consideration

The design of the BRRRI rice-wheat thresher encompasses several key elements to ensure durability, stability, and operational efficiency:

Hopper and Feeding Mechanism: The design of the hopper and feeding mechanism is crucial for ensuring efficient grain intake and distribution within the thresher. Reinforced walls and robust supports prevent deformation or damage under load, while the feeding mechanism is engineered for smooth and consistent grain flow to the threshing and cleaning components.

Threshing Mechanism: The heart of the BRRRI rice-wheat thresher is its threshing mechanism, meticulously engineered to deliver optimal performance across a range of crop types. Through a combination of beating, rubbing, and separating actions, the thresher effectively separates grains from stalks and husks while minimizing grain damage.

Cleaning System: A robust cleaning system is integral to maintaining grain quality and reducing post-harvest losses. The BRRRI thresher incorporates an innovative cleaning mechanism, comprising oscillating sieves, air blowers, and adjustable screens, to remove chaff, dust, and other impurities efficiently.

Power Transmission: Structural elements associated with power transmission, such as pulleys, belts, and shafts, are designed for optimal load distribution and energy efficiency. Robust mounting points and bearing supports ensure reliable power transmission with minimal deflection or loss.

Safety Guards and Shields: Structural elements such as safety guards and shields are incorporated to protect operators from moving parts and potential hazards. Constructed from durable materials and securely mounted, these components provide reliable protection without impeding access for maintenance or operation.

The design of the BRRRI rice-wheat thresher is characterized by robustness, reliability, and attention to detail, ensuring optimal performance and longevity in the demanding conditions of agricultural harvesting operations.

Purpose of developing BRRI rice wheat thresher

The development of the BRRI rice wheat thresher serves multiple purposes, primarily aimed at enhancing agricultural productivity and livelihoods. Here are some key purposes:

Increased Efficiency: The BRRI rice wheat thresher streamlines the post-harvest process by efficiently separating grains from stalks for both rice and wheat crops. This reduces the time and labor required for manual threshing, allowing farmers to focus on other essential tasks.

Cost Reduction: Mechanized threshing reduces the dependence on manual labor, which can be costly and time-consuming. By investing in the BRRI rice wheat thresher, farmers can lower labor costs and improve overall cost-effectiveness in agricultural operations.

Improved Grain Quality: Mechanized threshing tends to be more precise and gentle on grains compared to manual methods, resulting in higher-quality produce with minimal damage. This improves the market value of the harvested grains and enhances farmers' income potential.

Adaptability: The BRRI rice wheat thresher is likely designed to be adaptable to the diverse varieties of crops. This versatility ensures that farmers can effectively thresh their crops regardless of variations in grain size, moisture content, or other factors.

The purpose of developing the BRRI rice wheat thresher is to address the specific needs and challenges of farmers in regions where rice and wheat cultivation coexist, ultimately contributing to increased agricultural productivity, sustainability, and livelihood improvements.

Characteristics of BRRI rice-wheat thresher

The BRRI rice wheat thresher, developed by the Bangladesh Rice Research Institute (BRRI), exhibits several key characteristics tailored to the needs of farmers cultivating both rice and wheat:

Multiple-Functionality: This thresher is specifically designed to efficiently thresh both rice, wheat, lentil, mustard, mungbean, blackgram etc. It can handle the unique characteristics and requirements of these crops, providing versatility to farmers.

High Threshing Capacity: The BRRI rice wheat thresher is capable of processing large volumes of grains in a relatively short amount of time. This feature helps farmers manage harvests efficiently, especially during peak seasons.

Efficient Separation: The thresher effectively separates grains from the chaff, straw, and other non-edible parts of the plant. This ensures clean and thoroughly threshed grains, ready for further processing or storage.

Robust Construction: Built to withstand the demands of agricultural operations, the BRRI rice wheat thresher features a durable and rugged construction. This ensures longevity and reliability, even when used in challenging field conditions.

Ease of Operation: The thresher is designed for user-friendly operation, with intuitive controls and simple mechanisms that make it easy for farmers to operate and maintain. This accessibility is particularly important for smallholder farmers with limited technical expertise.

Affordability: While offering advanced features and capabilities, the thresher is designed to be affordable and accessible to smallholder farmers. This helps promote widespread adoption and contributes to the improvement of agricultural productivity and livelihoods.

Technical specifications

Name : BRRRI Rice-Wheat Thresher

Model : BRRRI TH2023

Taking, l=length, w=width, h=height, t=sheet thickness, \varnothing =diameter, r=radius.

1. Base structural frame: l=1705mm, h=941.4mm, w=1430mm, t=1.5mm.
2. Carrier: l=1037mm, h=85mm, w=435mm, t=1.5mm.
3. Blower casing (area of surface): l=1060mm, h=450mm, w=600mm, t=1.5mm.
4. Guard: l=1051mm, h=613mm, w=133mm, t=1.5mm.
5. Guard holding part [(25×3) mm flat bar]: l=860mm.
6. Engine carrying frame [(38×38×3) mm angle bar]: l=685mm, w=91mm.
7. Shaft holder [(50×10) mm metal plate]: l=155mm, w=50mm.
8. Rear wheel shaft: \varnothing =35mm, l=1000mm.
9. Nut M25×3.0: Quantity 03.
10. Wheel and rim: Size 4.00-8-Tire and its rim.
11. Ball bearing 6205: Quantity 10.
12. Shaft for front wheel: \varnothing =25mm, l=204mm.
13. Base handle [(25×25×3) mm square tube]: l=985mm, w=340mm.
14. Blower angle bar [(50×50×4) mm angle bar]: l=1060mm.
15. Threshing drum casing: l=1220mm, h=910mm, w=765mm, t=1.5mm.
16. Bearing housing: UCP-207. Quantity 02.
17. Thresher rotor: l=1425mm (full size with shaft length).
18. Thresher top enclose: r=280mm, l=1220mm, w=622mm, t=1.5mm.
19. Feeding tray: l=1430mm, h=240mm, w=665mm, t=1.5mm.
20. Feeding tray support: \varnothing =10mm, l=590mm.
21. Thresher pulley 1: \varnothing =180mm, t=78mm.
22. Thresher pulley 2: \varnothing =355mm, t=45mm.
23. Threshing drum threaded lock: \varnothing 14mm, l=195mm.
24. Threshing drum straw cutting blade: \varnothing =17mm, l=320mm.
25. Cleaner V-pulley: \varnothing =300mm, t=20.5mm.
26. UCP-206: Quantity 04.
27. Cleaner cam shaft: \varnothing =32mm, l=600mm.
28. Cleaner: l=1105mm, h=115mm, w=787mm, t=1.5mm.
29. Ball bearing 6202: Quantity 04.
30. Blower pulley: \varnothing =50mm, t=35mm.
31. Blower fan: \varnothing =32mm (shaft diameter), l=1152mm.
32. V-belt Type-B: B76 and B92.
33. Thresher safety casing: [larger (\varnothing) =440mm, smaller (\varnothing) =300mm, canter to canter distance=964mm], t=1.5mm, w=180.4mm.

N.B: A 16hp diesel engine and 2200 rpm are required to match with other rotating components (Just install when mounting the machine. No drawings but the mounting places has been defined).

N.B: Diesel engine pulley information's: Outer diameter (\varnothing) =152.4mm. Inner diameter will be the taken from the engine output shaft diameter. No drawing available for this part but the outer diameter has been defined for the manufacturers.

INDEX

SUB-ASSEMBLY NO.	DESCRIPTION	SHEET NO.	PAGE NO.
1	ASSEMBLY & SUB-ASSEMBLY	01 - 14	01
2	BASE_SUB-ASSEMBLY	15 - 44	15
3	THRESHING_DRUM_SUB-ASSEMBLY	45 - 68	45
4	OSCILLATING_CLEANER_SUB-ASSEMBLY	69 - 76	69
5	BLOWER_FAN_SUB-ASSEMBLY	77 - 81	77
6	V-BELT TYPE-B MODEL NO: B-76	82	82
7.	V-BELT TYPE-B MODEL NO: B-92	83	83
8.	THRESHER_SAFETY_CASING	84-87	84



BRRI RICE-WHEAT THRESHER



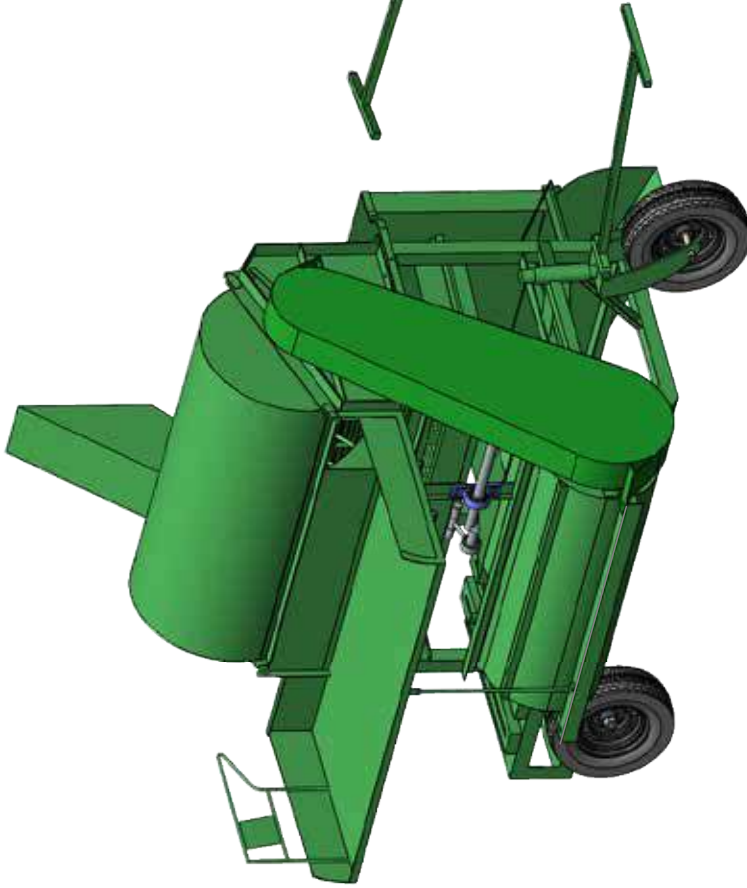

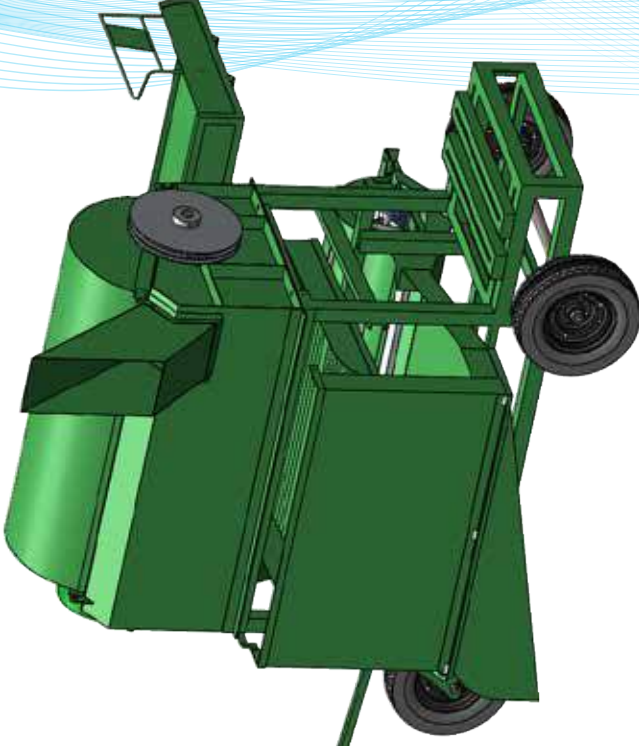

ISOMETRIC VIEW

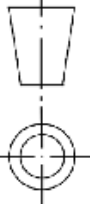

BACK-ISOMETRIC VIEW

UNLESS OTHERWISE SPECIFIED: STD. TOLERANCE DIMENSIONS ARE IN MILLIMETER MILLIMETER: ± 0.1, ANGULAR: ±0.05° * DOES NOT APPLY TO HOLE SIZE				BANGLADESH RICE RESEARCH INSTITUTE SFMRA PROJECT, FMPHT DIVISION		DO NOT SCALE DRAWING FINISH: NONE FIRST ISSUED: 15-APR-2024	
DETAILS NAME DRAWN ENGR. SHAFTER JAHAN KHAN CHK'D DR. MD. MOHARRAF HOSSAIN APP'VD DR. AKM SAIFUL ISLAM		SIGNATURE S J K M M H A S I		DATE 22-APR-2024 18-MAY-2024 20-JULY-2024		TITLE: BRRI RICE-WHEAT THRESHER (BRRI TH2023) DRG. NAME: BRRI RICE-WHEAT THRESHER FULL ASSEMBLY DWG NO: SFMRA-TH2023	
THIRD ANGLE PROJECTION: 				MANUFACTURING METHOD: FORGING, MACHINING, BENDING & WELDING WEIGHT: 447430.99 g SCALE: 1:20 SHEET: 01 REVISION: A		A4	

N.B: NOT A COMPLETE DRAWING.
 N.B: SHEET NUMBERS [1-3] PRESENTING BRRI RICE-WHEAT THRESHER FULL ASSEMBLY.
 N.B: TAKING DECIMAL PLACES: 01

BILL OF MATERIALS

ITEM NO.	Description	PartNo	QTY.
1	BASE_SUB-ASSEMBLY	SFMRA-TH2023-S1	1
2	OSCILLATING_CLEANER_SUB-ASSEMBLY	SFMRA-TH2023-S3	1
3	THRESHING_DRUM_SUB-ASSEMBLY	SFMRA-TH2023-S2	1
4	BLOWER_FAN_SUB-ASSEMBLY	SFMRA-TH2023-S4	1
5	V-BELT TYPE-B MODEL NO: B-76	SFMRA-S4-039	1
6	V-BELT TYPE-B MODEL NO: B-92	SFMRA-S4-040	1
7	THRESHER_SAFETY_CASTING	SFMRA-S4-041	1

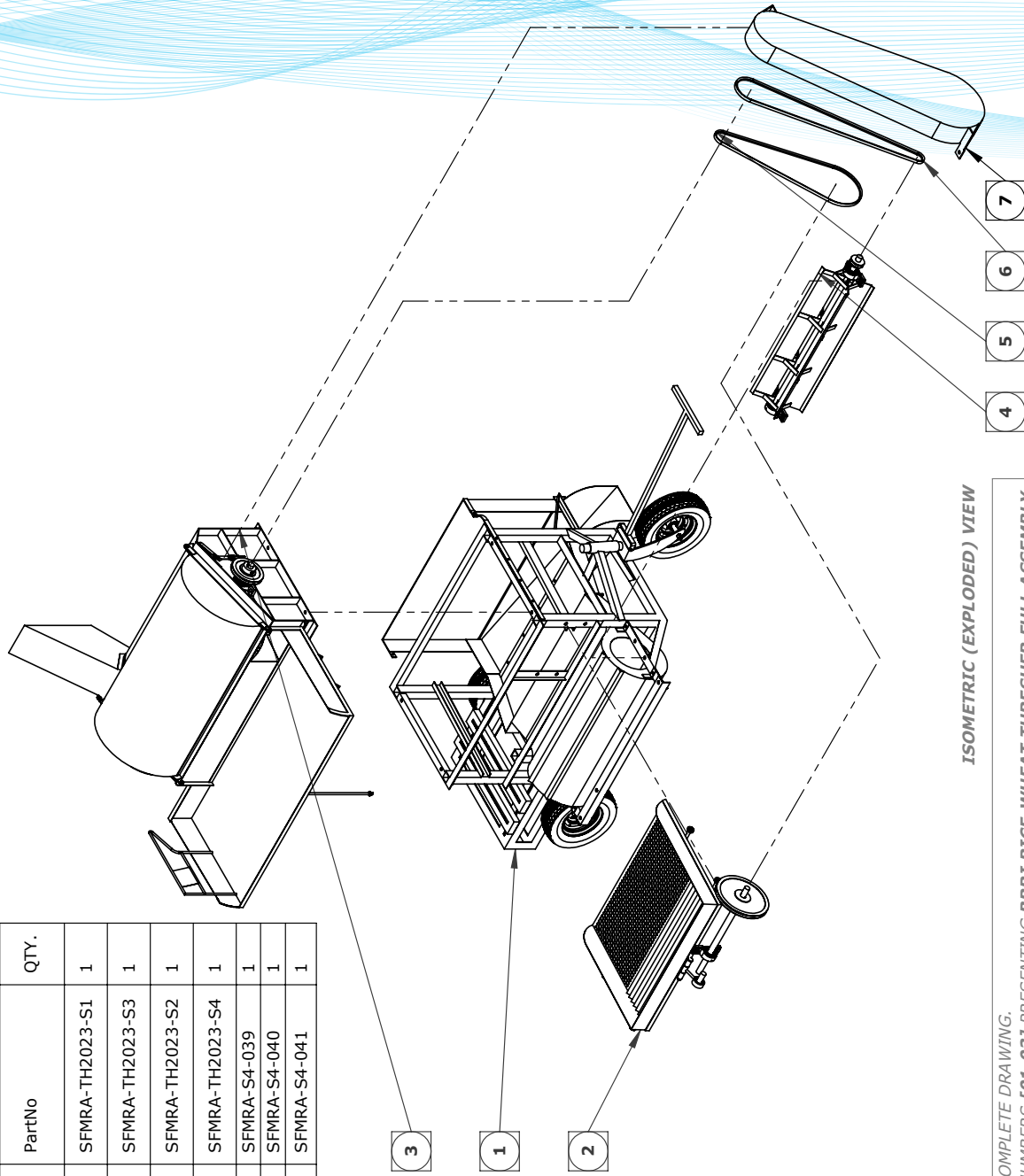

ISOMETRIC (EXPLODED) VIEW

DWG NO: SFMRA-TH2023
 SHEET: 02
 SCALE: 1:30

N.B: NOT A COMPLETE DRAWING.
 N.B: SHEET NUMBERS [01-03] REPRESENTING BRRI RICE-WHEAT THRESHER FULL ASSEMBLY.

PROJECTED VIEWS

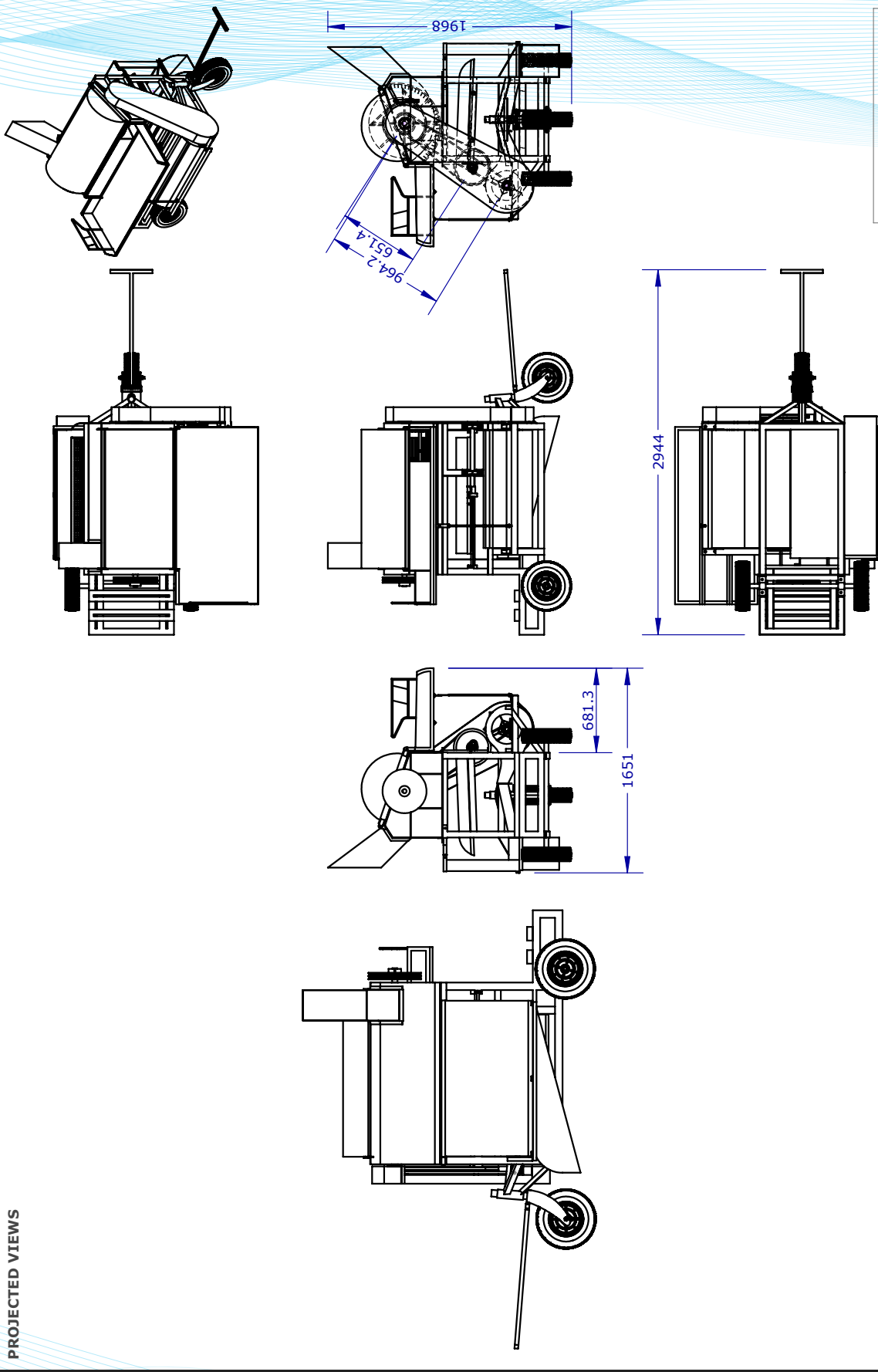



DWG NO: SFMRA-TH2023
SHEET: 03
SCALE: 1:40

N.B: NOT A COMPLETE DRAWING.
N.B: SHEET NUMBERS [1-3] REPRESENTING BRRI RICE-WHEAT THRESHER FULL ASSEMBLY.

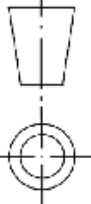

ISOMETRIC VIEW

UNLESS OTHERWISE SPECIFIED: STD. TOLERANCE DIMENSIONS ARE IN MILLIMETER MILLIMETER: ± 0.1, ANGULAR: ±0.05° * DOES NOT APPLY TO HOLE SIZE			BANGLADESH RICE RESEARCH INSTITUTE		DO NOT SCALE DRAWING
			SFMRA PROJECT, FMPHT DIVISION		
DETAILS	NAME	SIGNATURE	DATE	TITLE: BRRI RICE-WHEAT THRESHER (BRRI TH2023)	
DRAWN	ENGR. SHAFTER JAHAN KHAN	S J K	22-APR-2024	DRG. NAME: BASE_SUB-ASSEMBLY	
CHK'D	DR. MD. MOSHARRAF HOSSAIN	M M H	18-MAY-2024	DWG NO: SFMRA-TH2023-S1	
APP'VD	DR. AKM SAIFUL ISLAM	A S I	20-JULY-2024	MANUFACTURING METHOD: FORGING, MACHINING, BENDING & WELDING	
THIRD ANGLE PROJECTION:					
			WEIGHT: 1.66896.63 g SCALE: 1:14		REVISION: A

N.B: NOT A COMPLETE DRAWING.
N.B: SHEET NUMBERS [4-6] PRESENTING BASE SUB-ASSEMBLY.
N.B: TAKING DECIMAL PLACES: 01

BILL OF MATERIALS

ITEM NO.	DESCRIPTION	PART NO.	MATERIAL	QTY.
1	BASE STRUCTURAL FRAME	SFMRA-S1-001	ASTM A36 Steel	1
2	CARRIER - 1 (OUTPUT SIDE)	SFMRA-S1-002	PLAIN CARBON STEEL	1
3	BLOWER CASING	SFMRA-S1-003	PLAIN CARBON STEEL	1
4	GUARD	SFMRA-S1-004	PLAIN CARBON STEEL	1
5	GUARD HOLDING PART	SFMRA-S1-005	ASTM A36 Steel	1
6	SHAFT HOLDER	SFMRA-S1-007	PLAIN CARBON STEEL	2
7	REAR_WHEEL_SHAFT	SFMRA-S1-008	ASTM A36 STEEL	1
8	6205_RS_BEARING	SFMRA-S1-011	N/A	6
9	WHEEL_AND_RIM_FOR_4.00-8-TIRE	SFMRA-S1-010	N/A	3
10	FRONT_WHEEL_SUPPORT	SFMRA-S1-012	N/A	1
11	SHAFT_FOR_FRONT_WHEEL	SFMRA-S1-013	ASTM A36 STEEL	1
12	WHEEL_NUT_M16_(FRONT-X2)	SFMRA-S1-014	SS	2
13	BASE_HANDLE	SFMRA-S1-015	ASTM A36 Steel	1
14	ENGINE_CARRYING_FRAME	SFMRA-S1-006	ASTM A36 Steel	2
15	BLOWER_ANGLE_BAR	SFMRA-S1-016	ASTM A36 Steel	1
16	NUT_M25_FOR_REAR_WHEEL_SHAFT	SFMRA-S1-009	STAINLESS STEEL (FERRITIC)	2

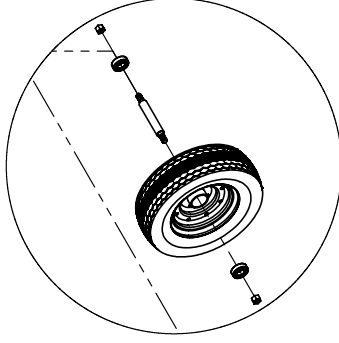

DETAIL A
SCALE 1 : 20

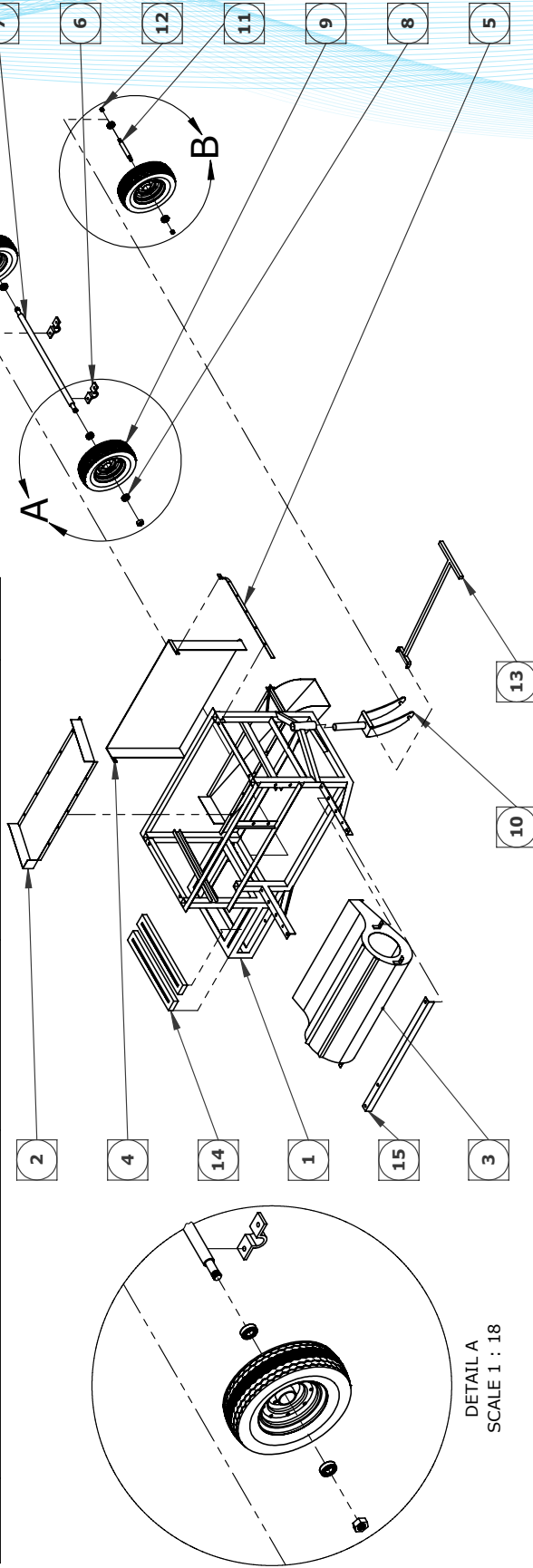

ISOMETRIC (EXPLODED) VIEW

N.B.: NOT A COMPLETE DRAWING.

N.B.: SHEET NUMBERS [4-6] PRESENTING BASE_SUB-ASSEMBLY.

DWG NO: SFMRA-TH2023-S1

SHEET: 05

SCALE: 1:40

DETAIL A
SCALE 1 : 18

PROJECTED VIEWS

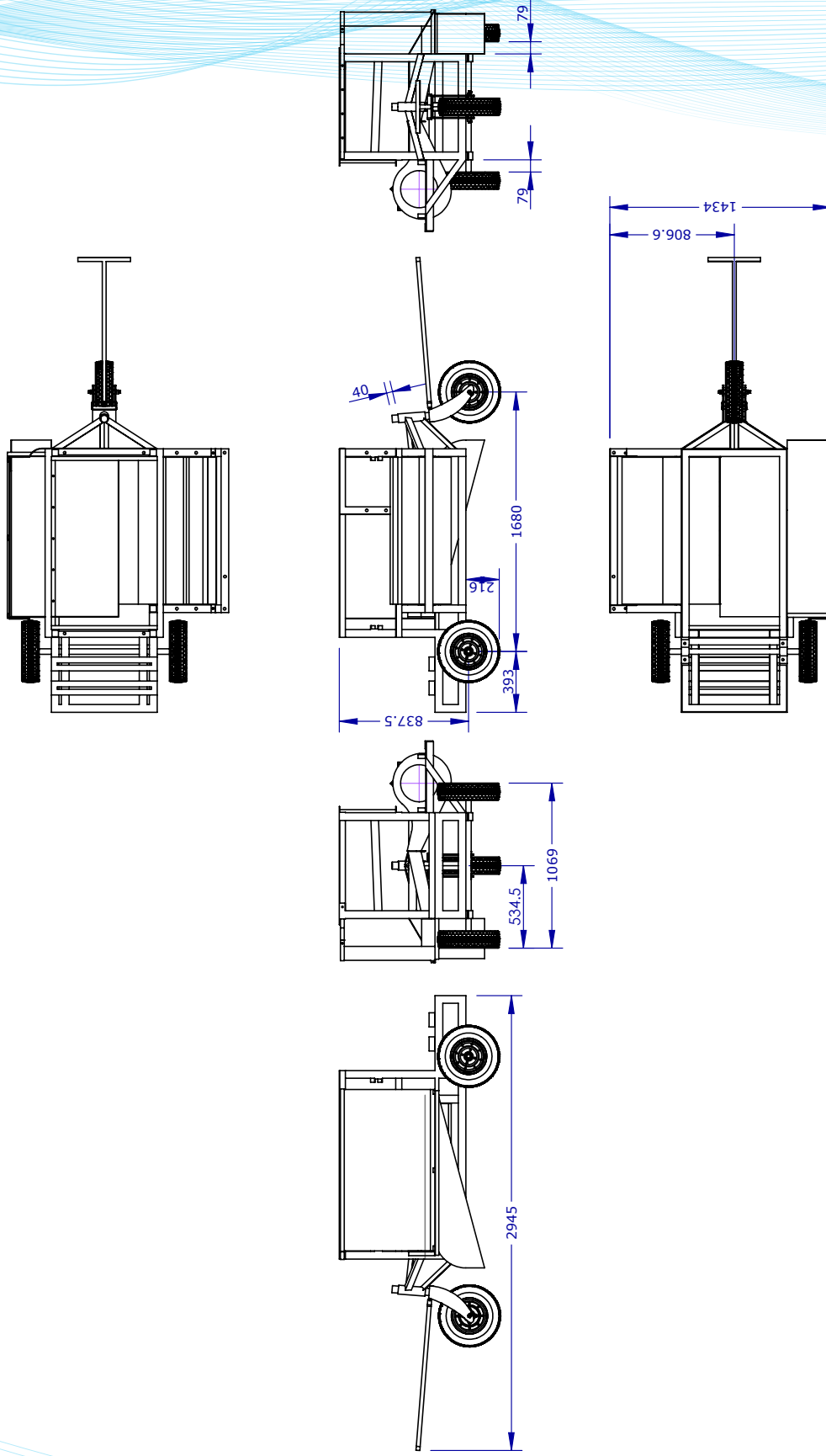

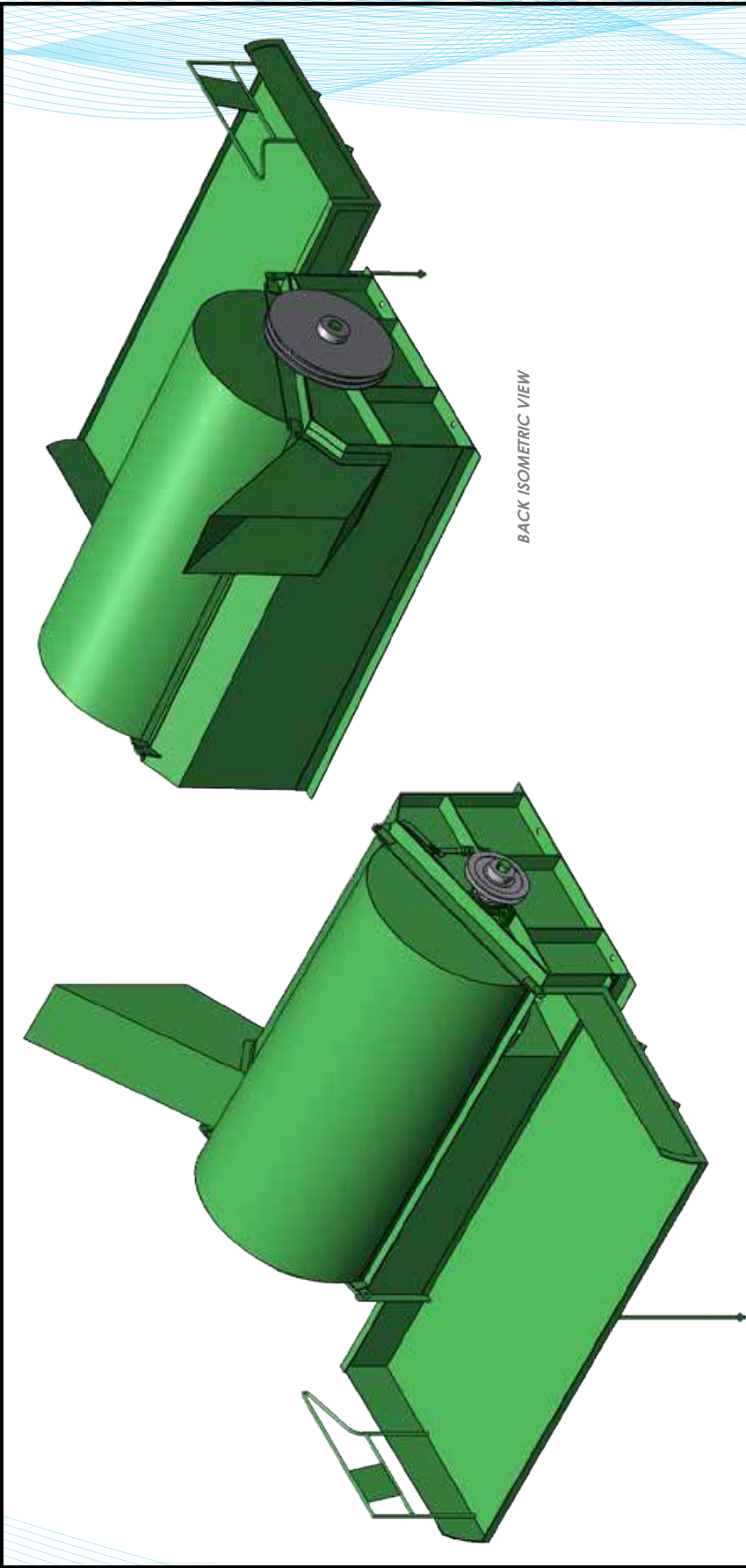

DWG NO: SFMRA-TH2023-S1
SHEET: 06
SCALE: 1:35

N.B: NOT A COMPLETE DRAWING.
N.B: SHEET NUMBERS [4-6] PRESENTING BASE_SUB-ASSEMBLY.



ISOMETRIC VIEW

BACK ISOMETRIC VIEW

UNLESS OTHERWISE SPECIFIED: STD. TOLERANCE DIMENSIONS ARE IN MILLIMETER MILLIMETER: ± 0.1, ANGULAR: ±0.05° * DOES NOT APPLY TO HOLE SIZE				BANGLADESH RICE RESEARCH INSTITUTE SFMRA PROJECT, FMPHT DIVISION		DO NOT SCALE DRAWING FINISH: NONE FIRST ISSUED: 15-APR-2024	
DETAILS		NAME	SIGNATURE	DATE	TITLE: BRRI RICE-WHEAT THRESHER (BRRI TH2023) DRG. NAME: THRESHING_DRUM_SUB-ASSEMBLY		
DRAWN	ENGR. SHAFTER JAHAN KHAN	S J K	[Signature]	22-APR-2024	DWG NO: SFMRA-TH2023-S2		
CHK'D	DR. MD. MOSHARRAF HOSSAIN	M M H	[Signature]	18-MAY-2024	MANUFACTURING METHOD: FORGING, MACHINING, BENDING & WELDING WEIGHT: 213317.49 g SCALE: 1:15		
APP'VD	DR. AKM SAIFUL ISLAM	A S I	[Signature]	20-JULY-2024	REVISION: A		
THIRD ANGLE PROJECTION:				SHEET: 07			

N.B: NOT A COMPLETE DRAWING.
 N.B: SHEET NUMBERS [7-10] PRESENTING
THRESHING_DRUM_SUB-ASSEMBLY.
 N.B: TAKING DECIMAL PLACES: 01

BILL OF MATERIALS

ITEM NO.	DESCRIPTION	PART NO.	MATERIAL	QTY.
1	THRASHING_DRUM_CASING	SFMRA-S2-017	PLAIN CARBON STEEL	1
2	UCP-207	SFMRA-S2-018	N/A	2
3	THRASHER_ROTOR	SFMRA-S2-019	PLAIN CARBON STEEL	1
4	THRASHER_TOP_ENCLOSER	SFMRA-S2-020	PLAIN CARBON STEEL	1
5	FEEDING_TRAY	SFMRA-S2-021	PLAIN CARBON STEEL	1
6	FEEDING TRAY SUPPORT	SFMRA-S2-022	ASTM A36 Steel	1
7	THRASHER_PULLEY-1	SFMRA-S2-023	GRAY CAST IRON	1
8	THRASHER_PULLEY-2	SFMRA-S2-024	GRAY CAST IRON	1
9	THRASHING_DRUM-STRAW_CUTTING_BLADE	SFMRA-S2-026	ASTM A36 Steel	1
10	NUT_M16	SFMRA-S2-027	STAINLESS STEEL (FERRITIC)	4
11	THRASHING_DRUM-THREADED LOCK	SFMRA-S2-025	PLAIN CARBON STEEL	1

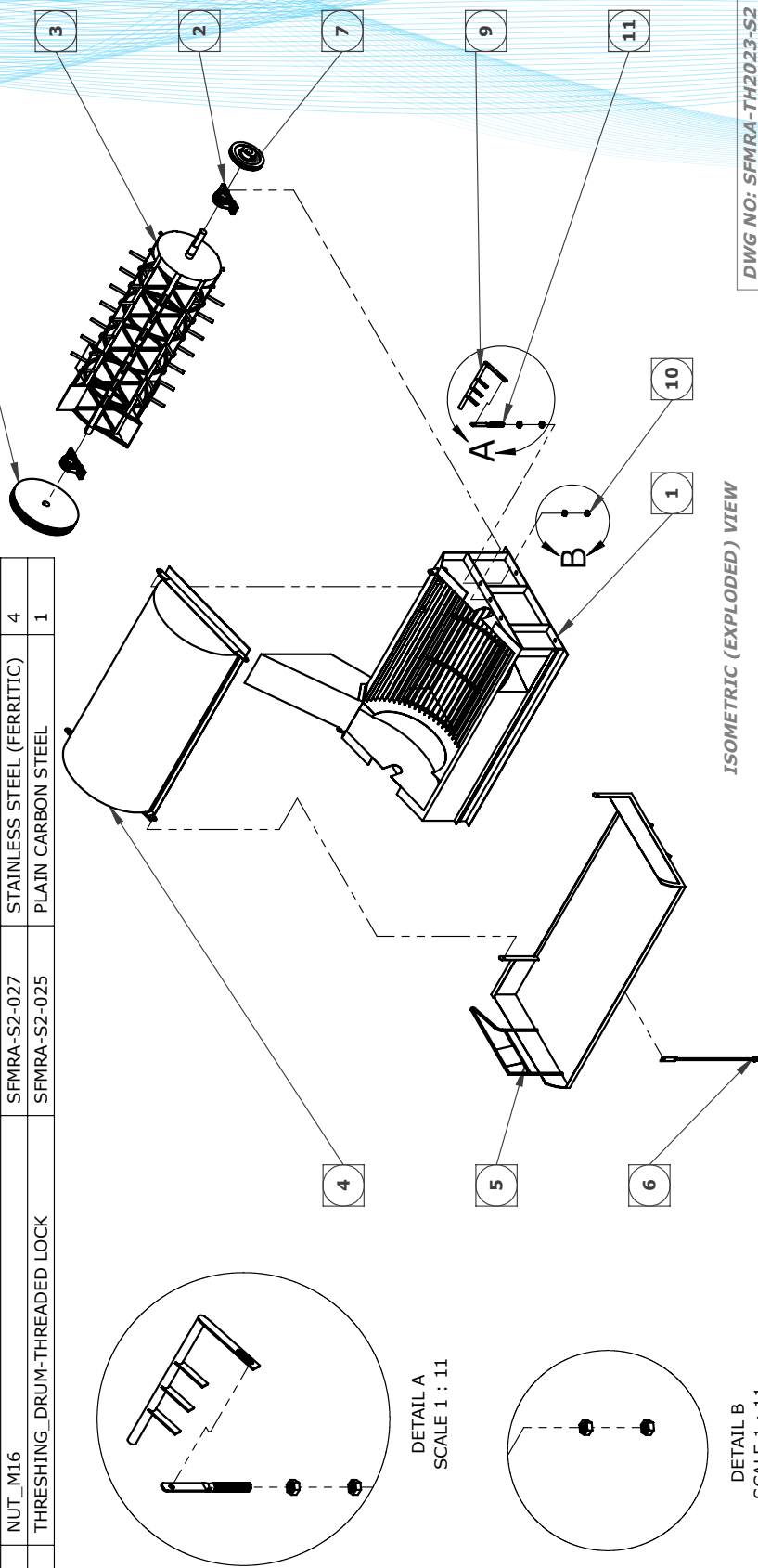

ISOMETRIC (EXPLODED) VIEW

N.B: NOT A COMPLETE DRAWING.

N.B: SHEET NUMBERS [07-10] REPRESENTING THRASHING_DRUM_SUB-ASSEMBLY.

DWG NO: SFMRA-TH2023-S2
SHEET: 08
SCALE: 1:30

DETAIL A
SCALE 1 : 11

DETAIL B
SCALE 1 : 11

PROJECTED VIEWS

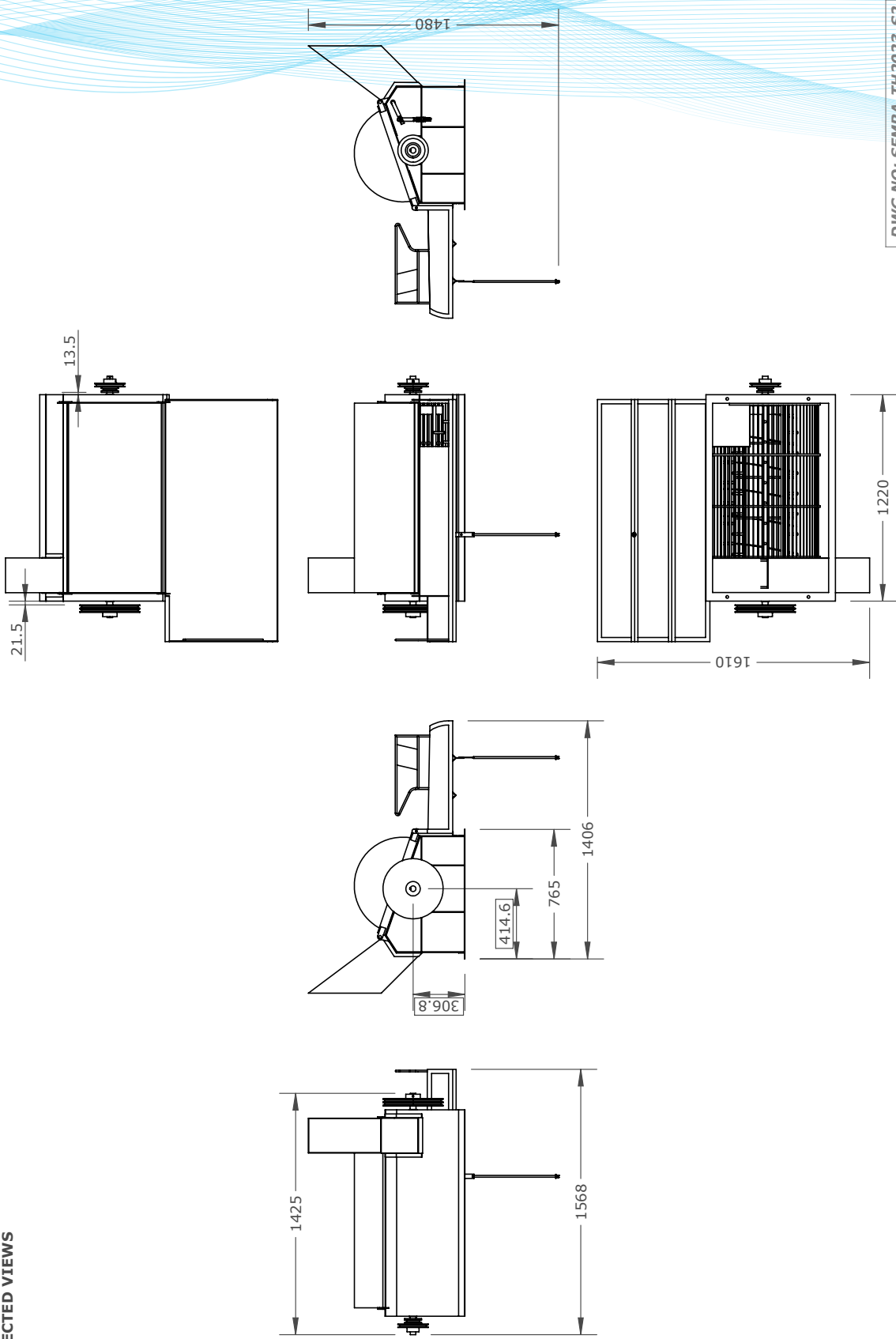

DWG NO: SFMRA-TH2023-S2
SHEET: 09
SCALE: 1:30

N.B: NOT A COMPLETE DRAWING.
N.B: SHEET NUMBERS [07-10] PRESENTING THRESHING_DRUM_SUB-ASSEMBLY.

MOUNTING INFORMATIONS: FROM THE LEFT VIEW

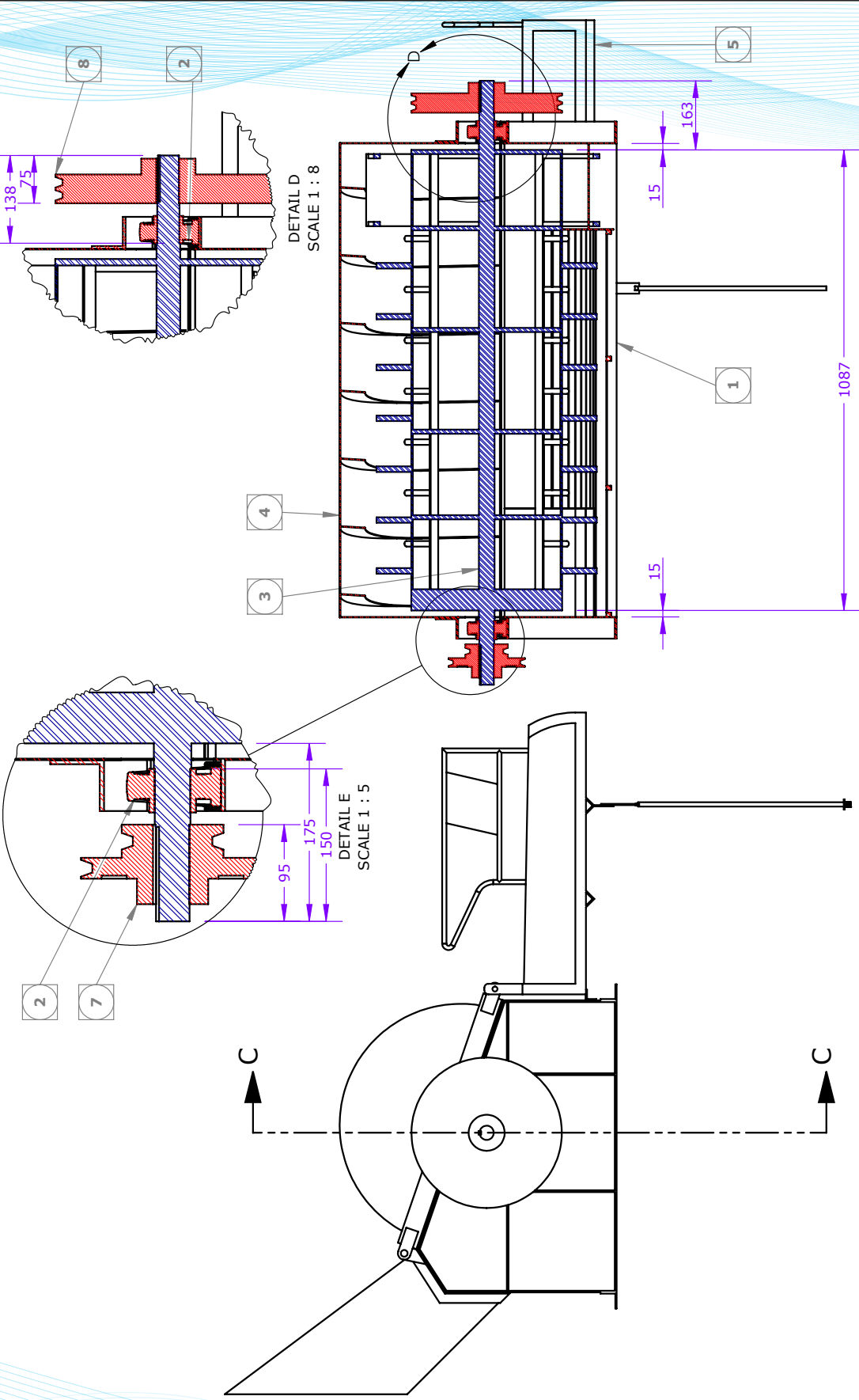

DWG NO: SFMRA-TH2023-S2
SHEET: 10
SCALE: 1:12

SECTION C-C
SCALE 1 : 12

N.B: NOT A COMPLETE DRAWING.
N.B: SHEET NUMBERS [07-10] REPRESENTING THRESHING_DRUM_SUB-ASSEMBLY.

BILL OF MATERIALS

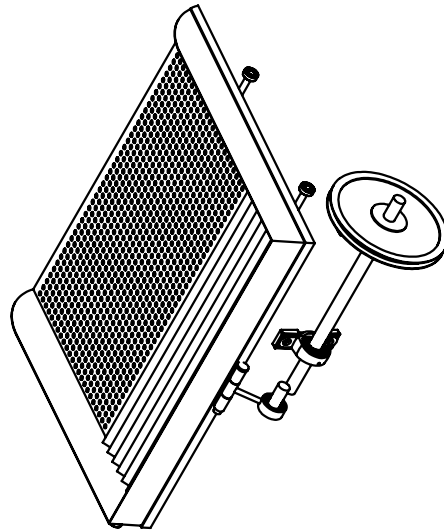

ITEM NO.	DESCRIPTION	PARTNO	MATERIAL	QTY.
1	UCP206	SFMRA-S3-029	N/A	2
2	CLEANER_CAM-SHAFT	SFMRA-S3-030	PLAIN CARBON STEEL	1
3	6205_RS_BEARING	SFMRA-S3-031	N/A	1
4	BEARING_HOLDER	SFMRA-S3-032	PLAIN CARBON STEEL	1
5	LOCKING_PIN	SFMRA-S3-033	STAINLESS STEEL (FERRITIC)	1
6	CLEANER_V-PULLEY_TYPE-B	SFMRA-S3-028	GRAY CAST IRON	1
7	CLEANER	SFMRA-S3-034	PLAIN CARBON STEEL	1
8	BEARING_6202	SFMRA-S3-035	N/A	4

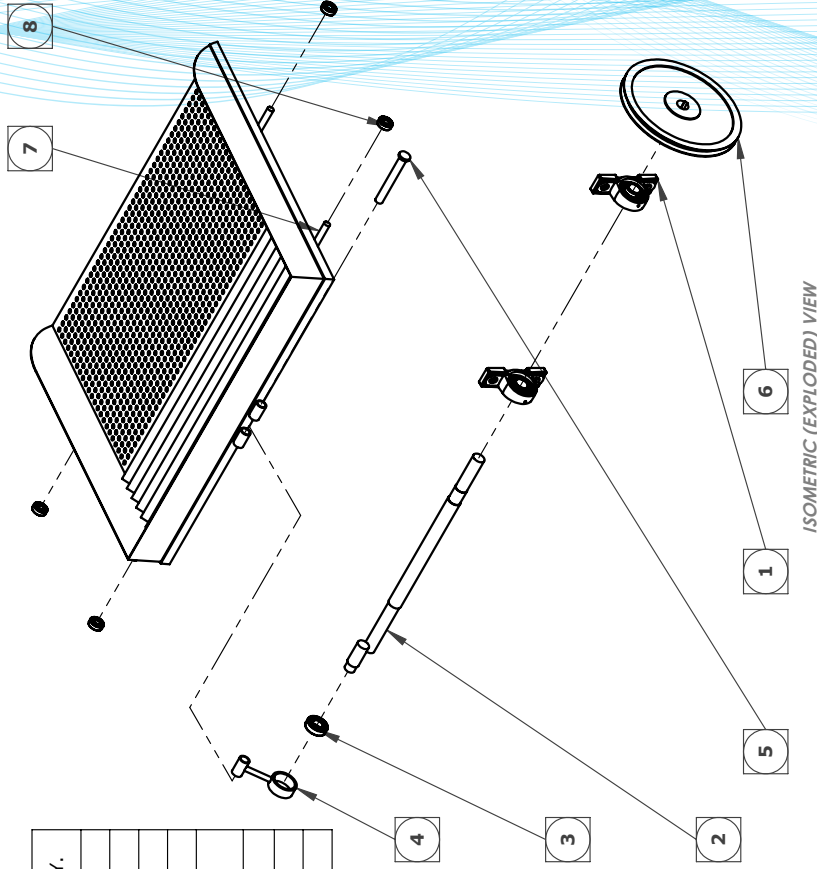

ISOMETRIC VIEW

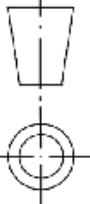

ISOMETRIC (EXPLODED) VIEW

		BANGLADESH RICE RESEARCH INSTITUTE SFMRA PROJECT, FMPHT DIVISION		DO NOT SCALE DRAWING FINISH: NONE FIRST ISSUED: 15-APR-2024
UNLESS OTHERWISE SPECIFIED: STD. TOLERANCE DIMENSIONS ARE IN MILLIMETER MILLIMETER: ± 0.1, ANGULAR: ±0.05° * DOES NOT APPLY TO HOLE SIZE		TITLE: BRRI RICE-WHEAT THRESHER (BRRI TH2023) DRG. NAME: OSCILLATING_CLEANER_SUB-ASSEMBLY DWG NO: SFMRA-TH2023-S3	MANUFACTURING METHOD: FORGING, MACHINING, BENDING & WELDING WEIGHT: 37465.16 g SCALE: 1:15	
DETAILS DRAWN: ENGR. SHAFTER JAHAN KHAN CHK'D: DR. MD. MOSHARRAF HOSSAIN APP'VD: DR. AKM SAIFUL ISLAM	NAME S J K M M H A S I	SIGNATURE DATE 22-APR-2024 18-MAY-2024 20-JULY-2024	THIRD ANGLE PROJECTION: 	
		SHEET: 11 REVISION: A		

N.B: NOT A COMPLETE DRAWING.
 N.B: SHEET NUMBERS [11-12] PRESENTING
OSCILLATING_CLEANER_SUB-ASSEMBLY.
 N.B: TAKING DECIMAL PLACES: 01

PROJECTED VIEWS

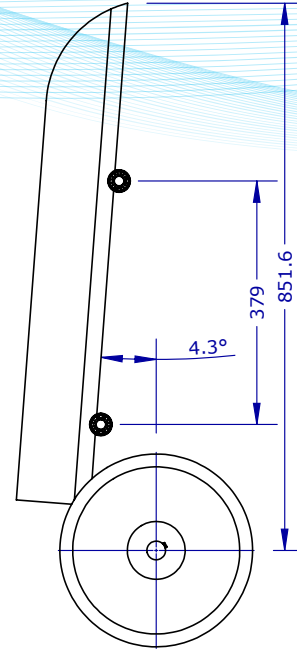
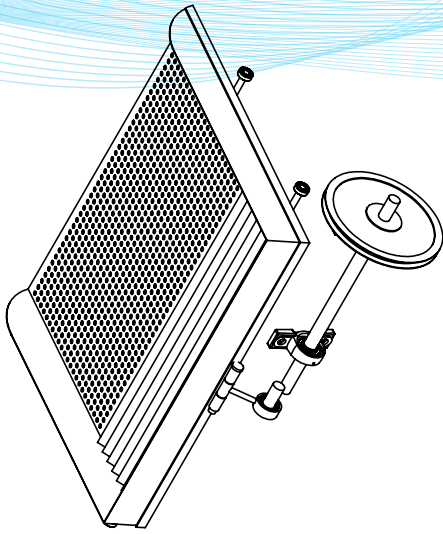
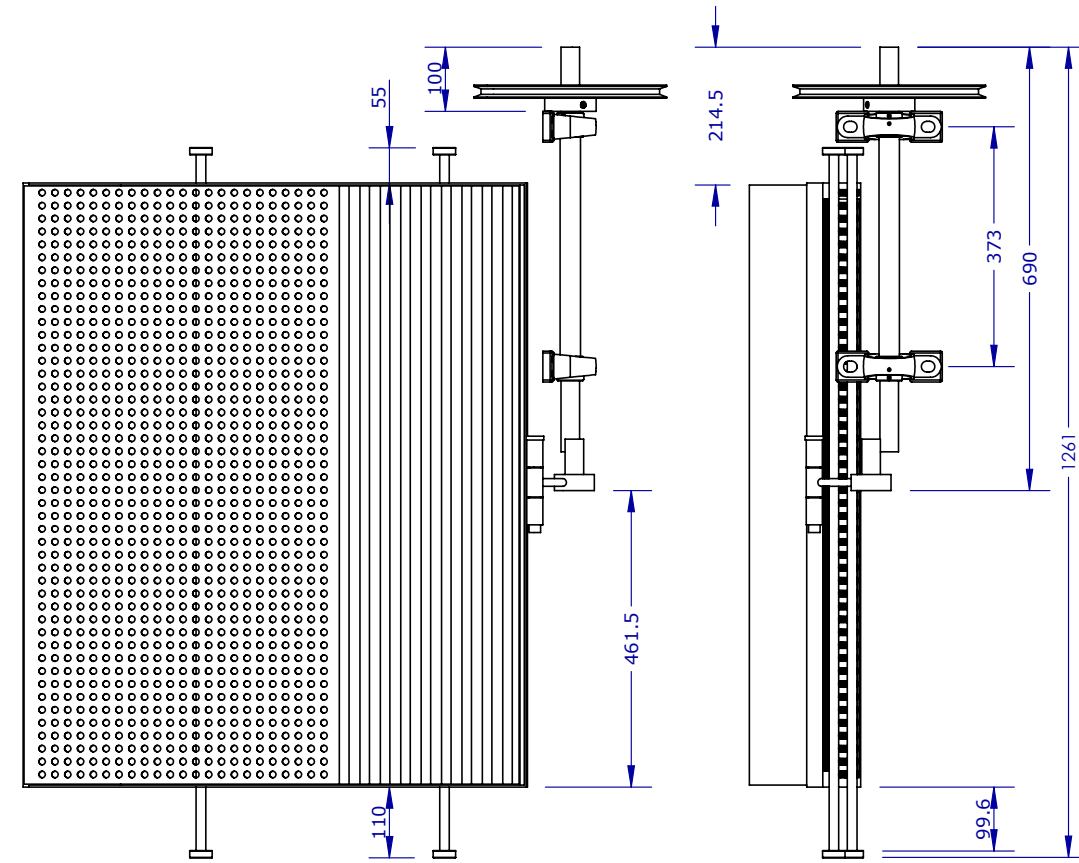

DWG NO: SFMRA-TH2023-S3
SHEET: 12
SCALE: 1:10

N.B: NOT A COMPLETE DRAWING.
N.B: SHEET NUMBERS [11-12] PRESENTING OSCILLATING CLEANER SUB-ASSEMBLY.

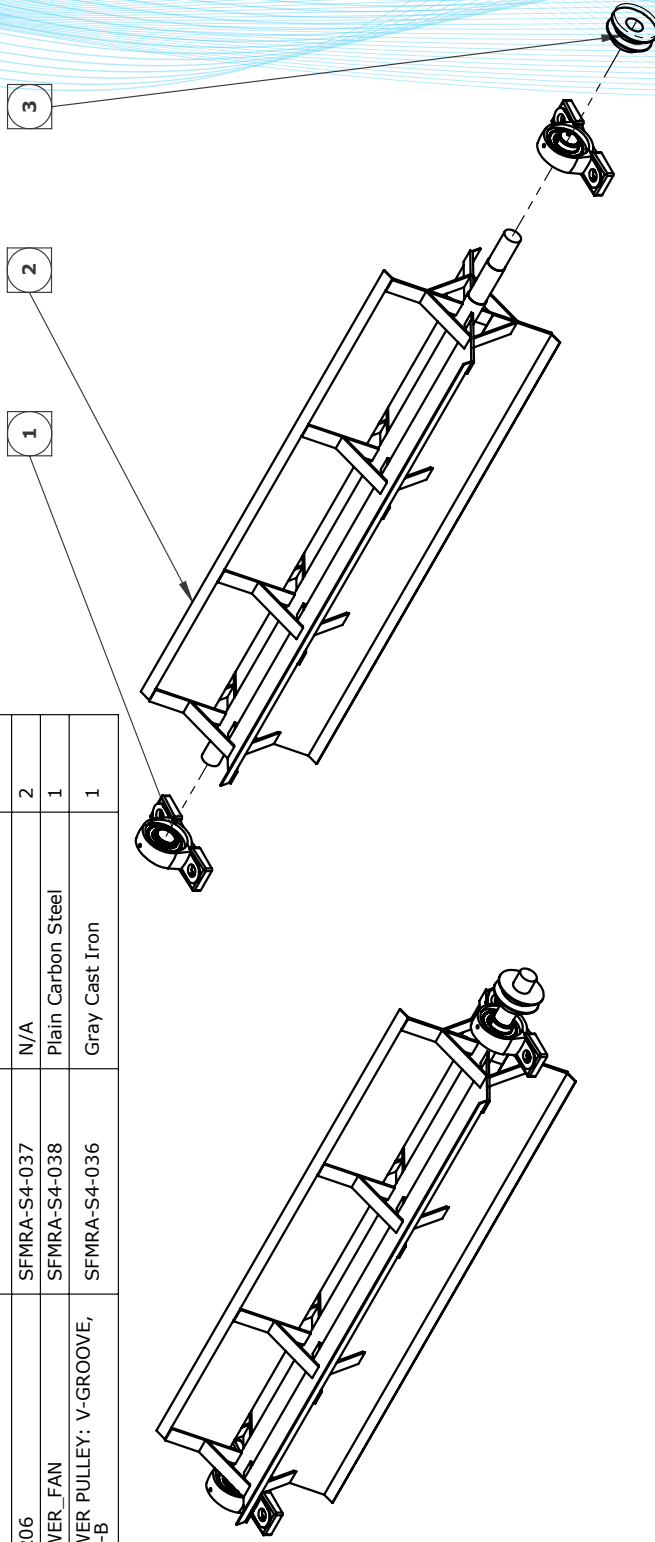

BILL OF MATERIALS

ITEM NO.	Description	PartNo	Material	QTY.
1	UCP206	SFMRA-S4-037	N/A	2
2	BLOWER_FAN	SFMRA-S4-038	Plain Carbon Steel	1
3	BLOWER PULLEY: V-GROOVE, TYPE-B	SFMRA-S4-036	Gray Cast Iron	1

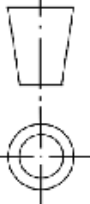

ISOMETRIC VIEW

ISOMETRIC (EXPLODED) VIEW

UNLESS OTHERWISE SPECIFIED: STD. TOLERANCE DIMENSIONS ARE IN MILLIMETER MILLIMETER: ± 0.1, ANGULAR: ±0.05° * DOES NOT APPLY TO HOLE SIZE			BANGLADESH RICE RESEARCH INSTITUTE SFMRA PROJECT, FMPHT DIVISION		DO NOT SCALE DRAWING
	FINISH: NONE FIRST ISSUED: 15-APR-2024				
TITLE: BRRRICE-WHEAT THRESHER (BRRITH2023)					
DRG. NAME: BLOWER_FAN_SUB-ASSEMBLY					
DWG NO: SFMRA-TH2023-S4					
MANUFACTURING METHOD: FORGING, MACHINING, BENDING & WELDING					
WEIGHT: 1.7211.15 g				A4	
SCALE: 1:10		SHEET: 13		REVISION: A	
THIRD ANGLE PROJECTION:					
DETAILS		NAME ENGR. SHAFTER JAHAN KHAN	SIGNATURE S J K	DATE 22-APR-2024	
DRAWN DR. MD. MOHARRAF HOSSAIN	NAME DR. MD. MOHARRAF HOSSAIN	SIGNATURE M M H	DATE 18-MAY-2024		
APPVD DR. AKM SAIFUL ISLAM	NAME DR. AKM SAIFUL ISLAM	SIGNATURE A S I	DATE 20-JULY-2024		
					

N.B: NOT A COMPLETE DRAWING.
 N.B: SHEET NUMBERS [13-14] PRESENTING
BLOWER_FAN_SUB-ASSEMBLY.

N.B: TAKING DECIMAL PLACES: 01

PROJECTED VIEWS

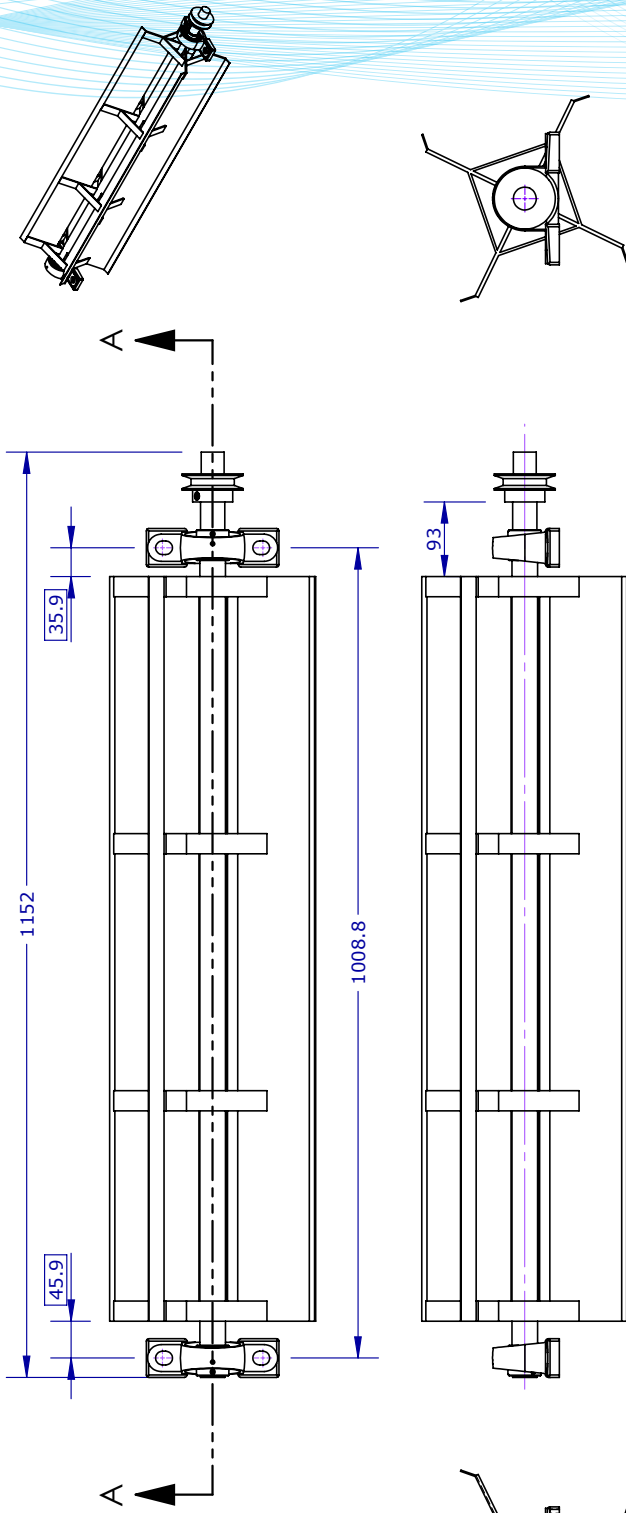

MOUNTING INFORMATION

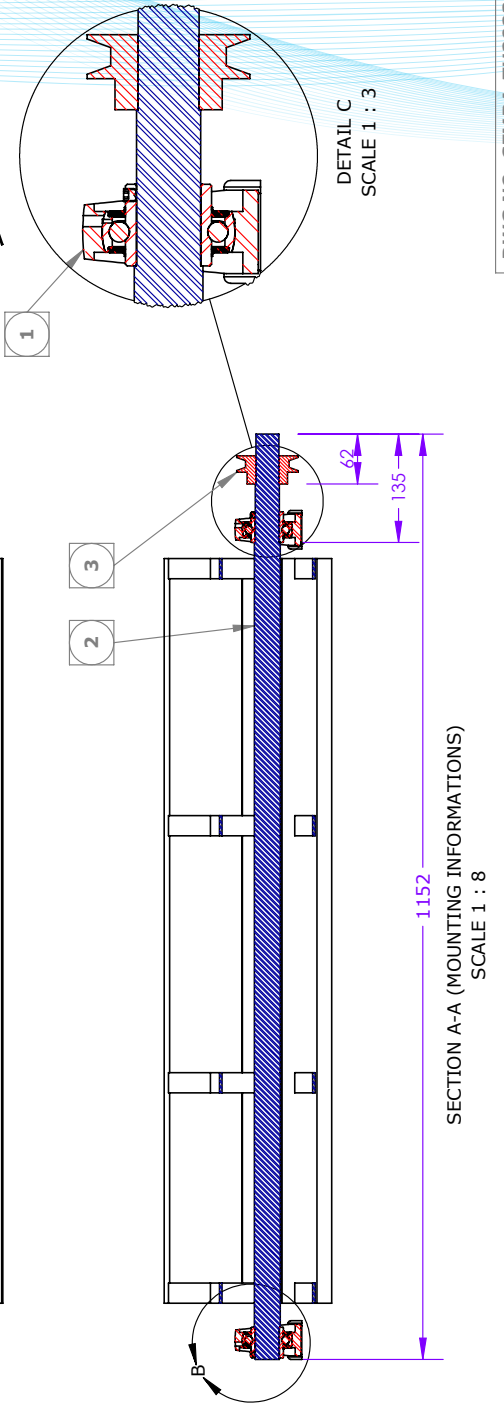



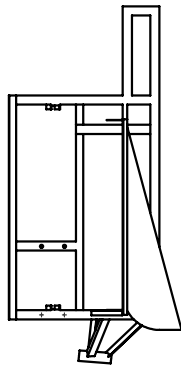
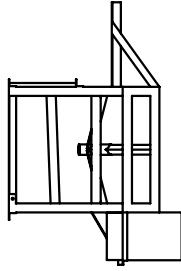
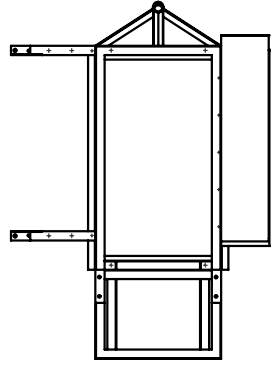
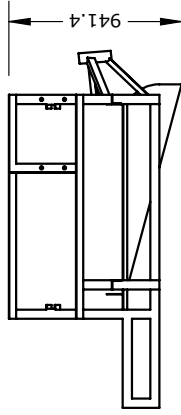
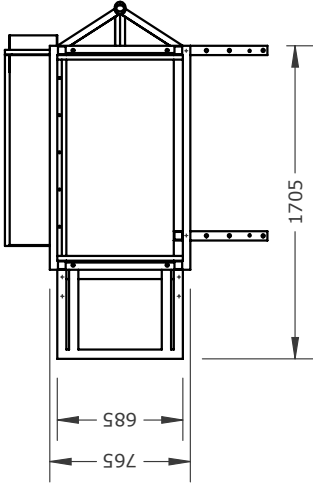
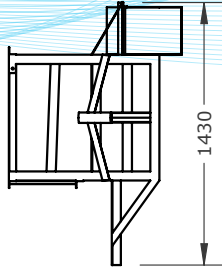
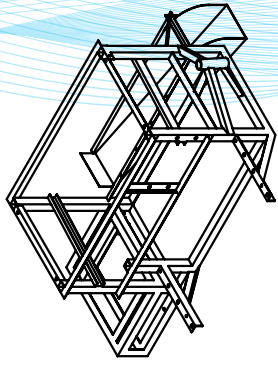

DWG NO: SFMRA-TH2023-S4
SHEET: 14
SCALE: 1:8

N.B: NOT A COMPLETE DRAWING.
N.B: SHEET NUMBERS [13-14] REPRESENTING BLOWER_FAN_SUB-ASSEMBLY.

DETAIL B
SCALE 1 : 3



		BANGLADESH RICE RESEARCH INSTITUTE SFMRA PROJECT, FMPHT DIVISION		DO NOT SCALE DRAWING FINISH: NONE FIRST ISSUED: 15-APR-2024	
UNLESS OTHERWISE SPECIFIED: STD. TOLERANCE DIMENSIONS ARE IN MILLIMETER MILLIMETER: ± 0.1, ANGULAR: ±0.05° * DOES NOT APPLY TO HOLE SIZE				TITLE: BRI RICE-WHEAT THRESHER (BRI TH2023) DRG. NAME: BASE STRUCTURAL FRAME	
DETAILS NAME DRAWN ENGR. SHAFTER JAHAN KHAN CHK'D DR. MD. MOHARRAF HOSSAIN APP'VD DR. AKM SAIFUL ISLAM		SIGNATURE S J K M M H A S I		DATE 02-MAY-2024 18-MAY-2024 20-JULY-2024	
		THIRD ANGLE PROJECTION: 		DWG NO: SFMR-S1-001 MANUFACTURING METHOD: MACHINING, BENDING & WELDING MATERIAL: ASTM A36 STEEL SCALE: 1:25 SHEET: 15 REVISION: A	
WEIGHT: 81664.78 g		SHEET: 15		REVISION: A	

N.B: NOT A COMPLETE DRAWING.
 N.B: SHEET NUMBERS (15-23) PRESENTING
BASE STRUCTURAL FRAME.
 N.B: SHEET THICKNESS 1.5mm.
 N.B: TAKING DECIMAL PLACES: 01

DETAILS: ISOMETRIC VIEW FRAME DETAILS ONLY.
 *SHEET MATERIAL: MILD STEEL.
 *FRAME MATERIALS: MILD STEEL.
 *NOT A COMPLETE DRAWING.
 N.B.: SHEET NUMBERS (15-23) PRESENTING
BASE STRUCTURAL FRAME.

NO.	DETAILS (mm)
1.	SQUARE BAR SIZE (50x50x4)
2.	ANGLE BAR SIZE (50x50x4)
3.	ANGLE BAR SIZE (40x40x3)
4.	ANGLE BAR SIZE (25x25x3)
5.	C-CHANNEL SIZE (50x25x4)
6.	FLAT BAR (25X3)
7.	SHEET THICKNESS IS 1.5

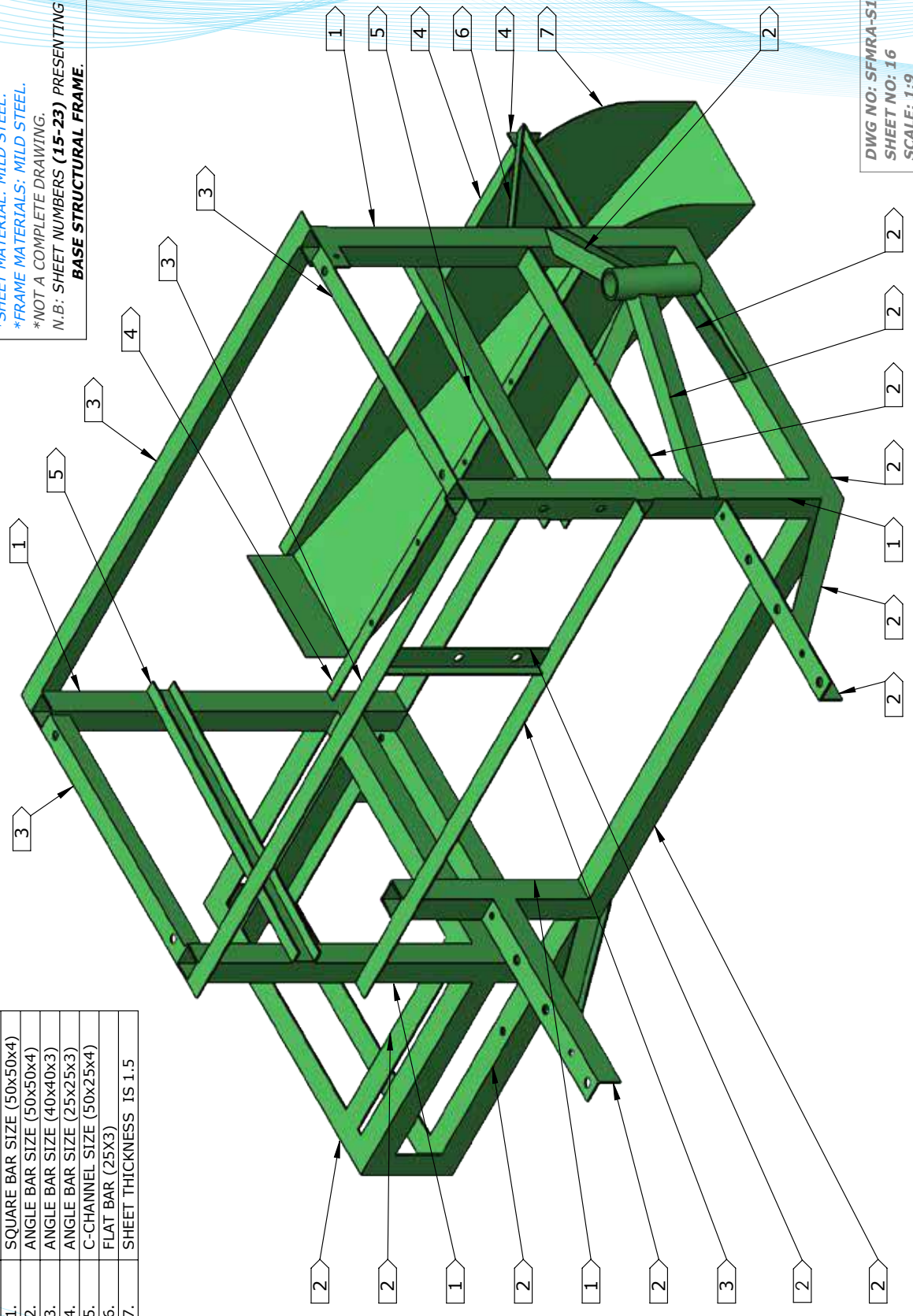

DWG NO: SFMRA-S1-001
 SHEET NO: 16
 SCALE: 1:9

COLOR INDICATING VERY IMPORTANT INFORMATION:
 1. SUB-ASSEMBLY "SFMRA_TH2023-S2" WILL MATE HERE.
 2. PART "SFMRA-S1-002" WILL MATE HERE.
 3. PART "SFMRA-S1-003" WILL MATE HERE.

N.B: ONLY TOP VIEW DIMENSIONS HAS SHOWN HERE.
 N.B: NOT A COMPLETE DRAWING.
 N.B: SHEET NUMBERS (15-23) PRESENTING BASE STRUCTURAL FRAME.

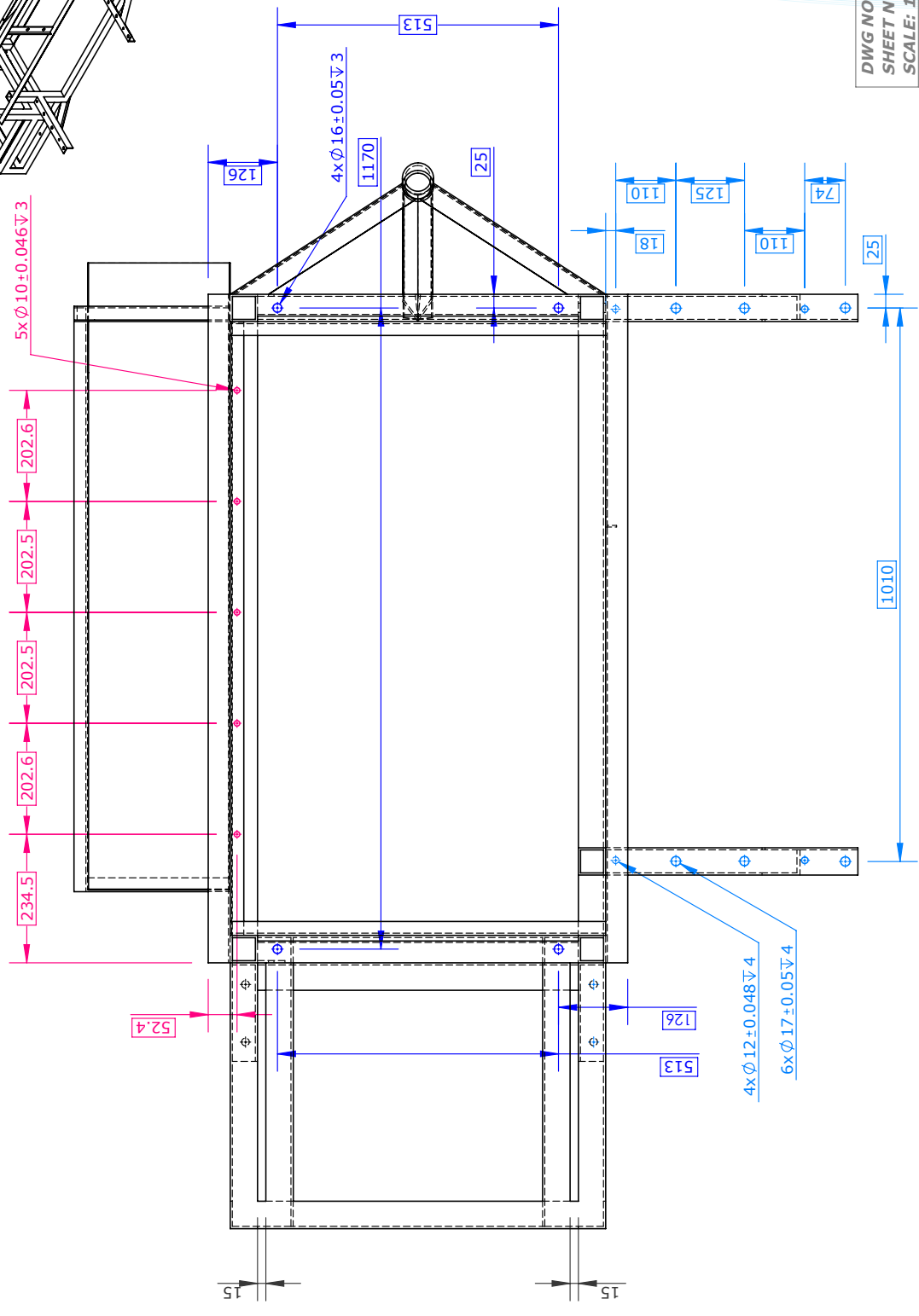
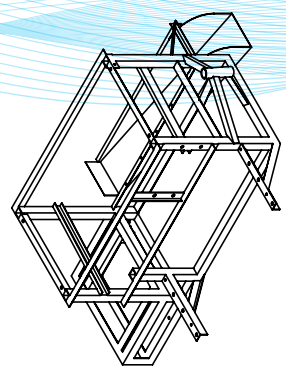

DWG NO: SFMRA-S1-001
 SHEET NO: 18
 SCALE: 1:10

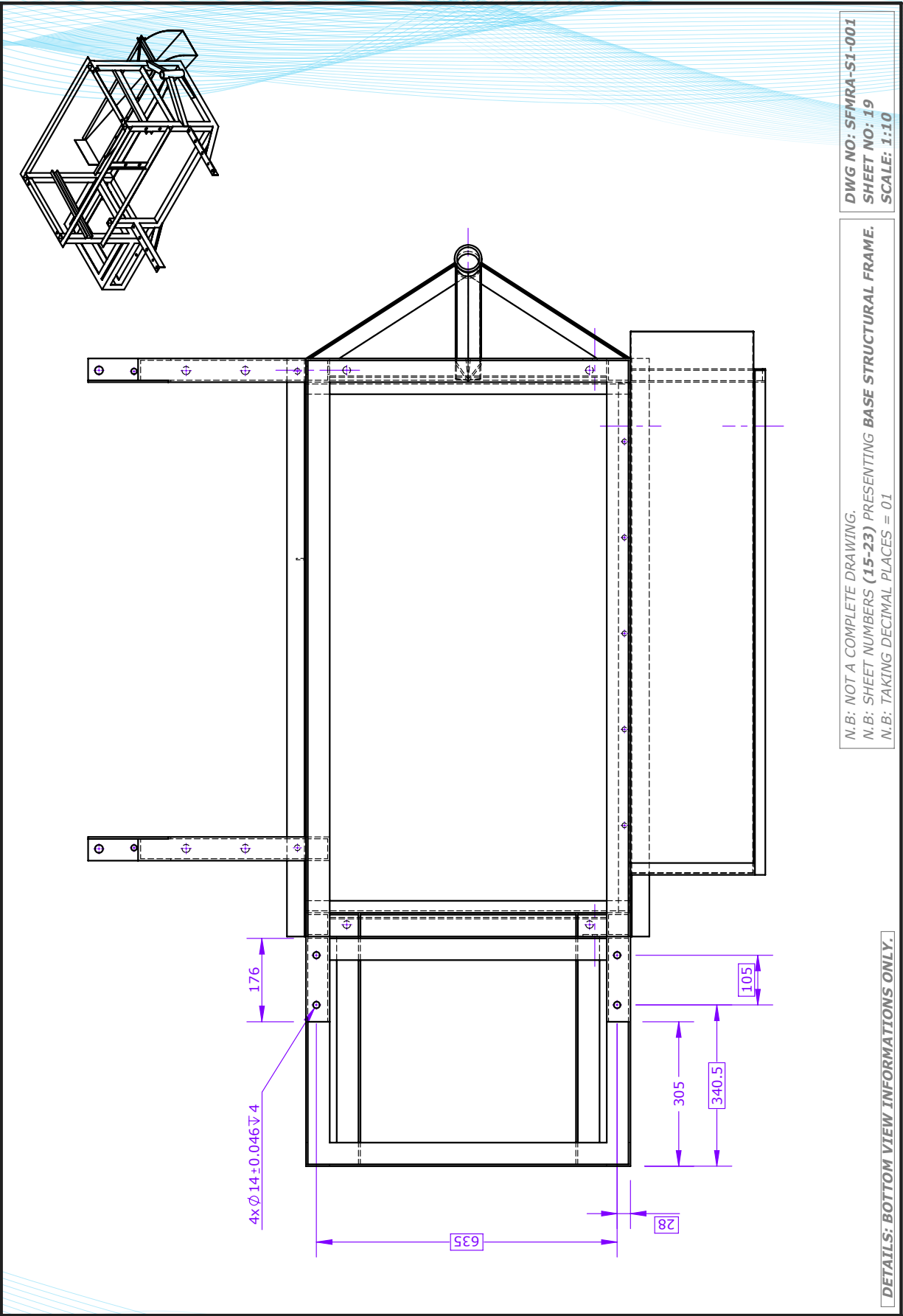

DWG NO: SFMRA-S1-001
 SHEET NO: 19
 SCALE: 1:10

N.B: NOT A COMPLETE DRAWING.
 N.B: SHEET NUMBERS (15-23) REPRESENTING BASE STRUCTURAL FRAME.
 N.B: TAKING DECIMAL PLACES = 01

DETAILS: BOTTOM VIEW INFORMATIONS ONLY.

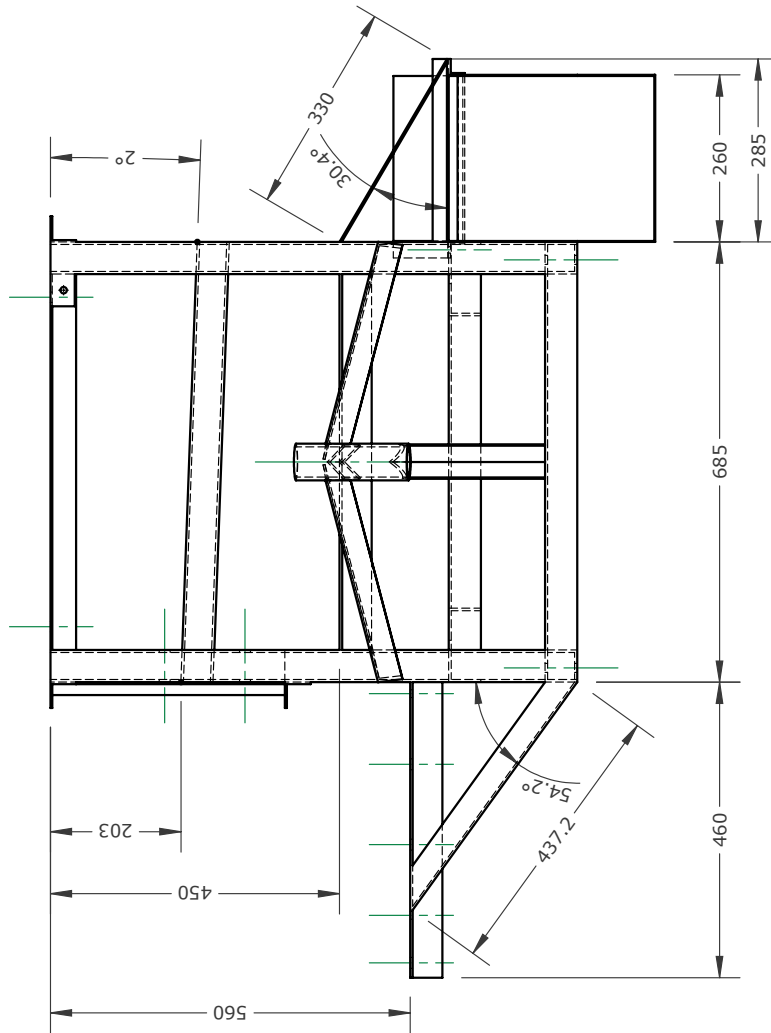
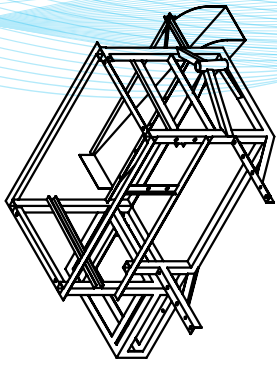

DWG NO: SFMRA-S1-001
 SHEET NO: 20
 SCALE: 1:10

N.B: NOT A COMPLETE DRAWING.
 N.B: SHEET NUMBERS (15-23) PRESENTING BASE STRUCTURAL FRAME.
 N.B: TAKING DECIMAL PLACES = 01

DETAILS: RIGHT VIEW INFORMATIONS ONLY.

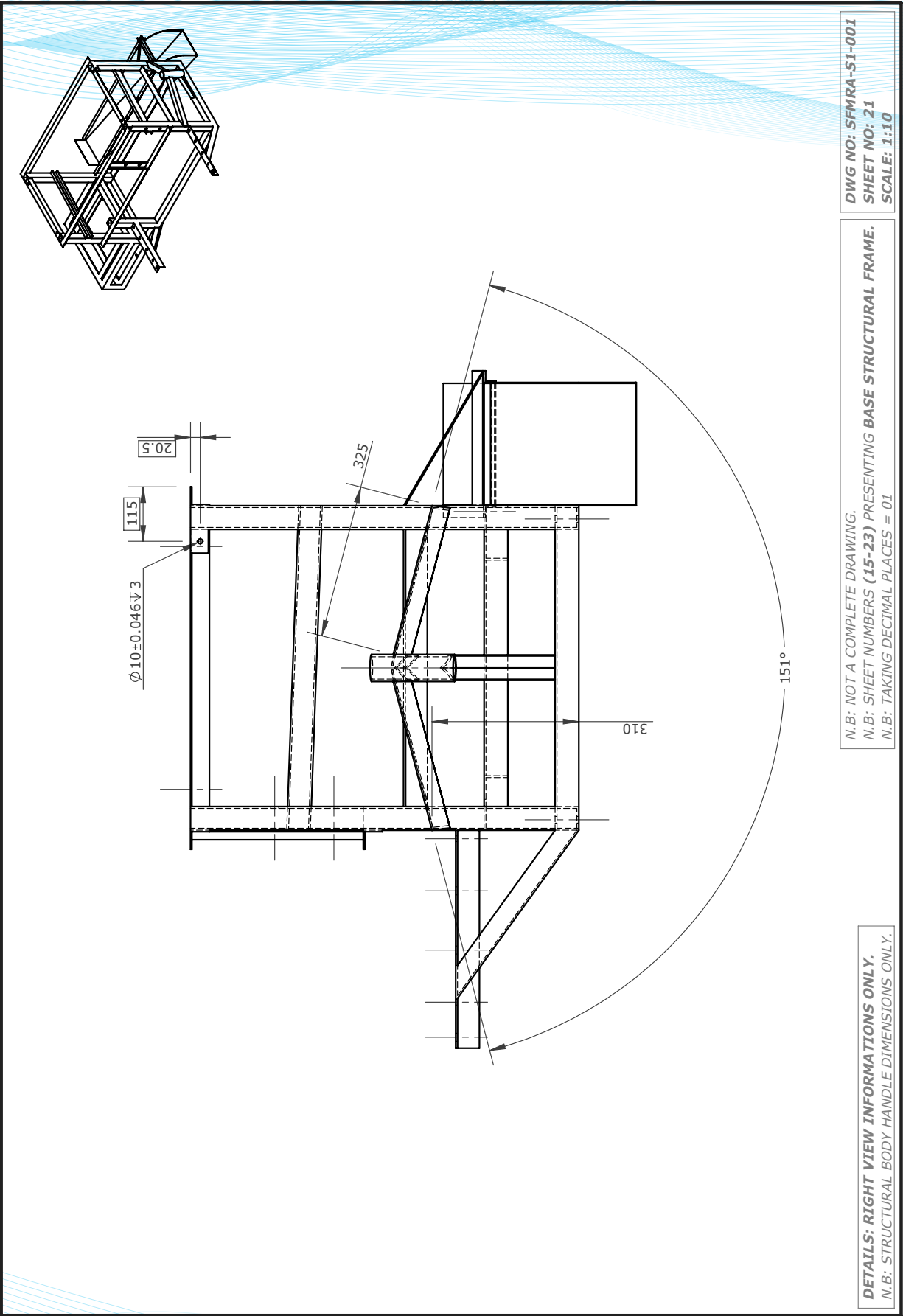

DWG NO: SFMRA-S1-001
 SHEET NO: 21
 SCALE: 1:10

N.B: NOT A COMPLETE DRAWING.
 N.B: SHEET NUMBERS (15-23) REPRESENTING BASE STRUCTURAL FRAME.
 N.B: TAKING DECIMAL PLACES = 01

DETAILS: RIGHT VIEW INFORMATIONS ONLY.
 N.B: STRUCTURAL BODY HANDLE DIMENSIONS ONLY.

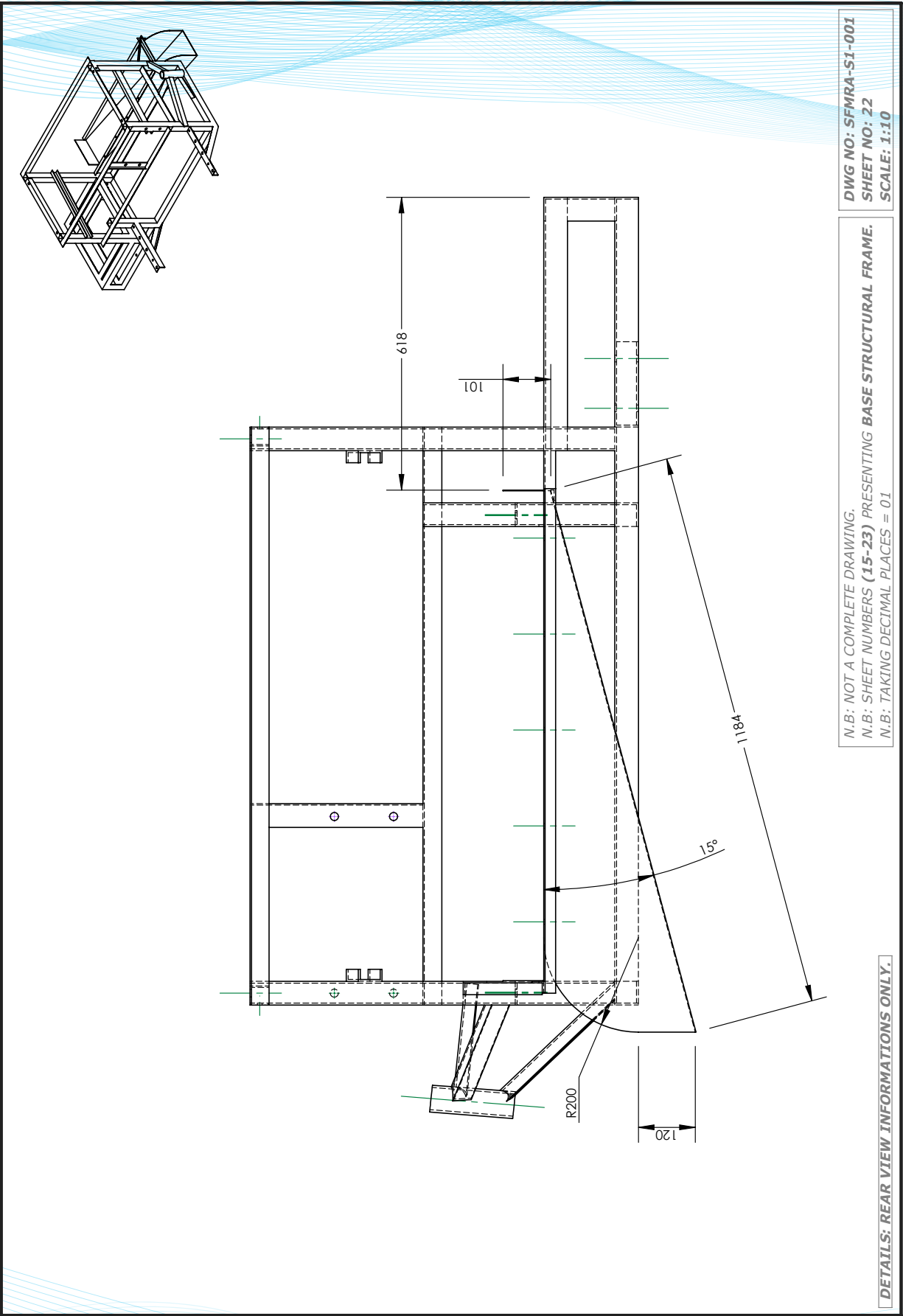

DWG NO: SFMRA-S1-001
SHEET NO: 22
SCALE: 1:10

N.B: NOT A COMPLETE DRAWING.
N.B: SHEET NUMBERS (15-23) PRESENTING BASE STRUCTURAL FRAME.
N.B: TAKING DECIMAL PLACES = 01

DETAILS: REAR VIEW INFORMATIONS ONLY.

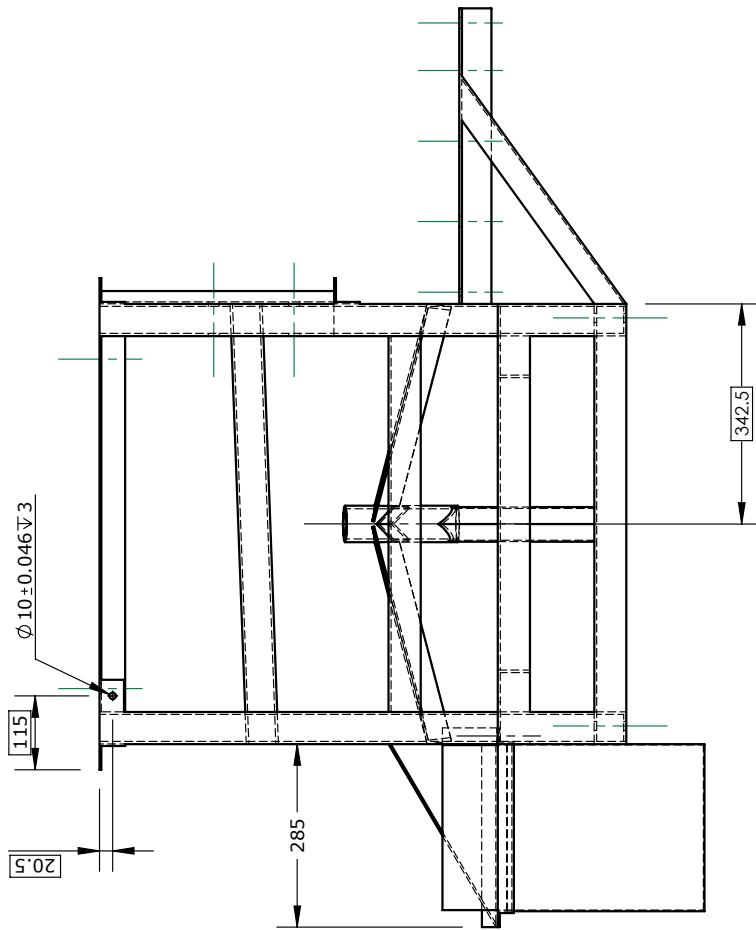
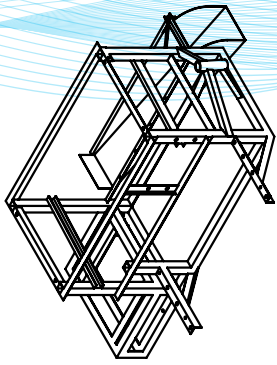

DWG NO: SFMRA-S1-001
SHEET NO: 23
SCALE: 1:10

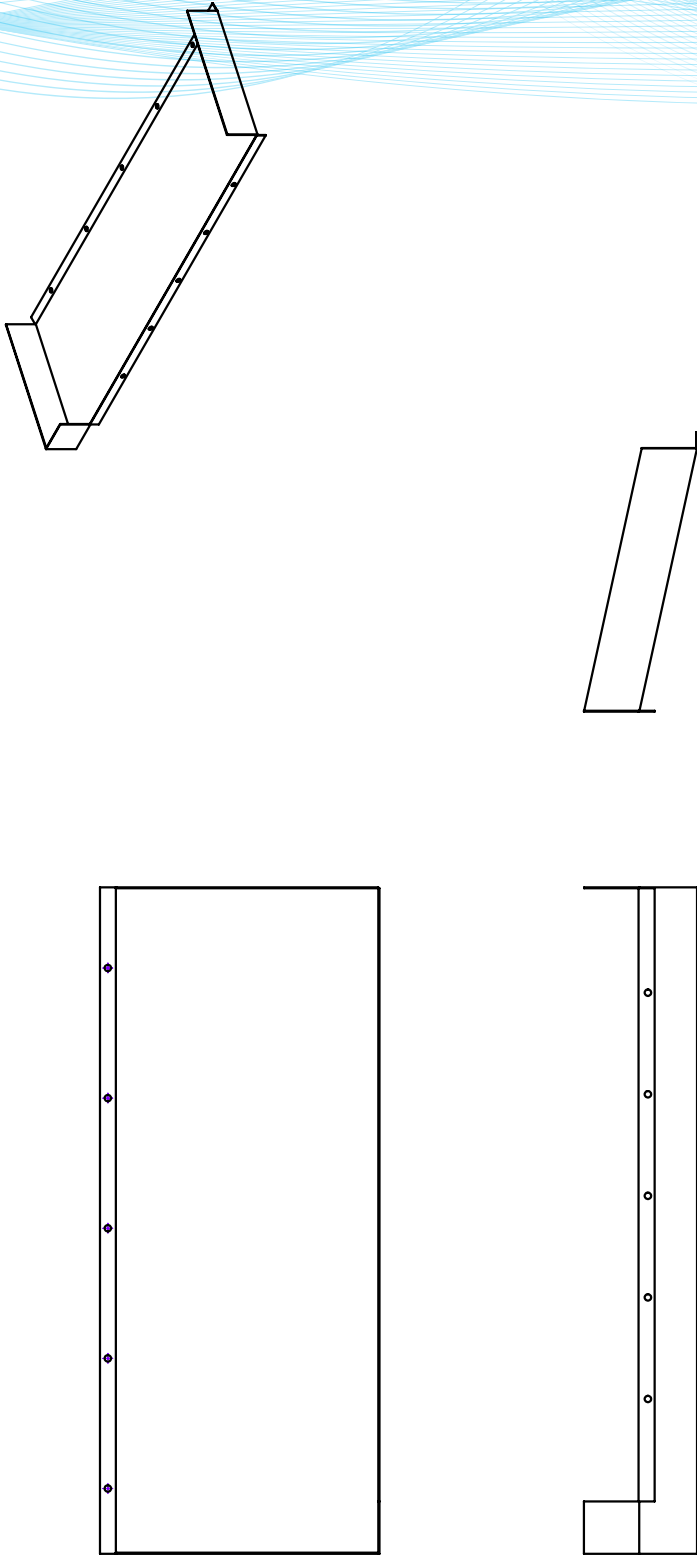

N.B: NOT A COMPLETE DRAWING.
N.B: SHEET NUMBERS (15-23) PRESENTING BASE STRUCTURAL FRAME.
N.B: TAKING DECIMAL PLACES = 01

DETAILS: LEFT VIEW INFORMATIONS ONLY.



*N.B: NOT A COMPLETE DRAWING.
N.B: SHEET THICKNESS 1.5mm.
N.B: SHEET NUMBERS (24-26) PRESENTING CARRIER - 1 (OUTPUT SIDE).
N.B: TAKING DECIMAL PLACES = 01*

N.B: TAKING DECIMAL PLACES: 01

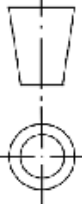
UNLESS OTHERWISE SPECIFIED: STD. TOLERANCE DIMENSIONS ARE IN MILLIMETER MILLIMETER: ± 0.1, ANGULAR: ±0.05° * DOES NOT APPLY TO HOLE SIZE				BANGLADESH RICE RESEARCH INSTITUTE SFMRA PROJECT, FMPHT DIVISION		DO NOT SCALE DRAWING	
DETAILS	NAME	SIGNATURE	DATE	TITLE: BRRI RICE-WHEAT THRESHER (BRRI TH2023)			
DRAWN	ENGR. SHAFIET JAHAN KHAN	S J K	02-MAY-2024	DRG. NAME: CARRIER - 1 (OUTPUT SIDE)			
CHK'D	DR. MD. MOSHARRAF HOSSAIN	M M H	18-MAY-2024	DWG NO: SFMRA-S1-002			
APP'VD	DR. AKM SAIFUL ISLAM	A S I	20-JULY-2024	MANUFACTURING METHOD: MACHINING, BENDING & WELDING			
			THIRD ANGLE PROJECTION: 		MATERIAL: PLAIN CARBON STEEL		WEIGHT: 6538.65 g
			SCALE: 1:10		SHEET: 24		REVISION: A

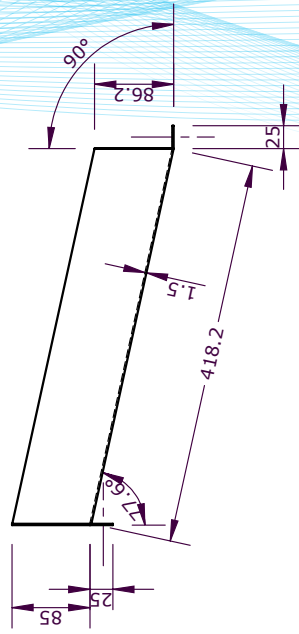
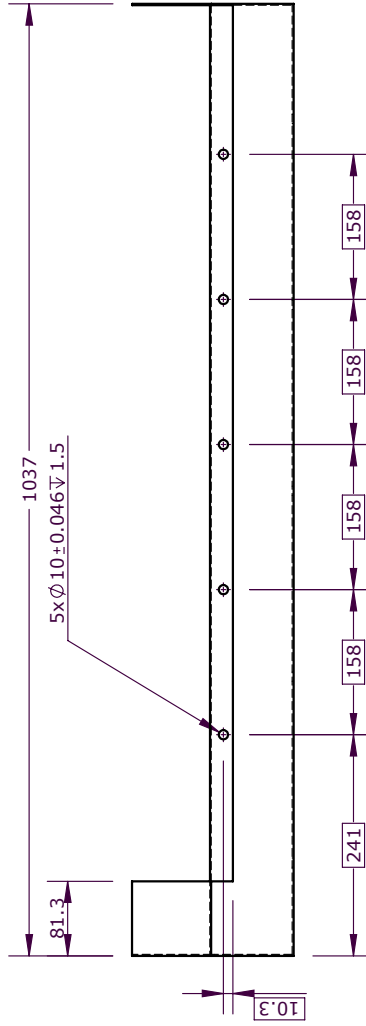
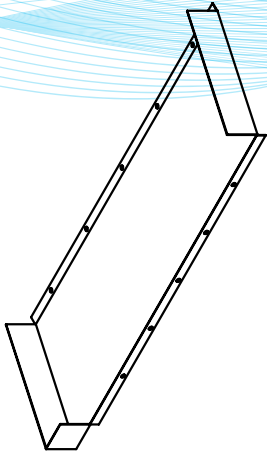

N.B: NOT A COMPLETE DRAWING.
 N.B: SHEET THICKNESS 1.5mm.
 N.B: SHEET NUMBERS (24-26) PRESENTING CARRIER - 1 (OUTPUT SIDE).
 N.B: TAKING DECIMAL PLACES = 01

DWG NO: SFMRA-S1-002
 SHEET NO: 25
 SCALE: 1:7

DETAILS: FRONT & RIGHT VIEW INFORMATIONS ONLY.

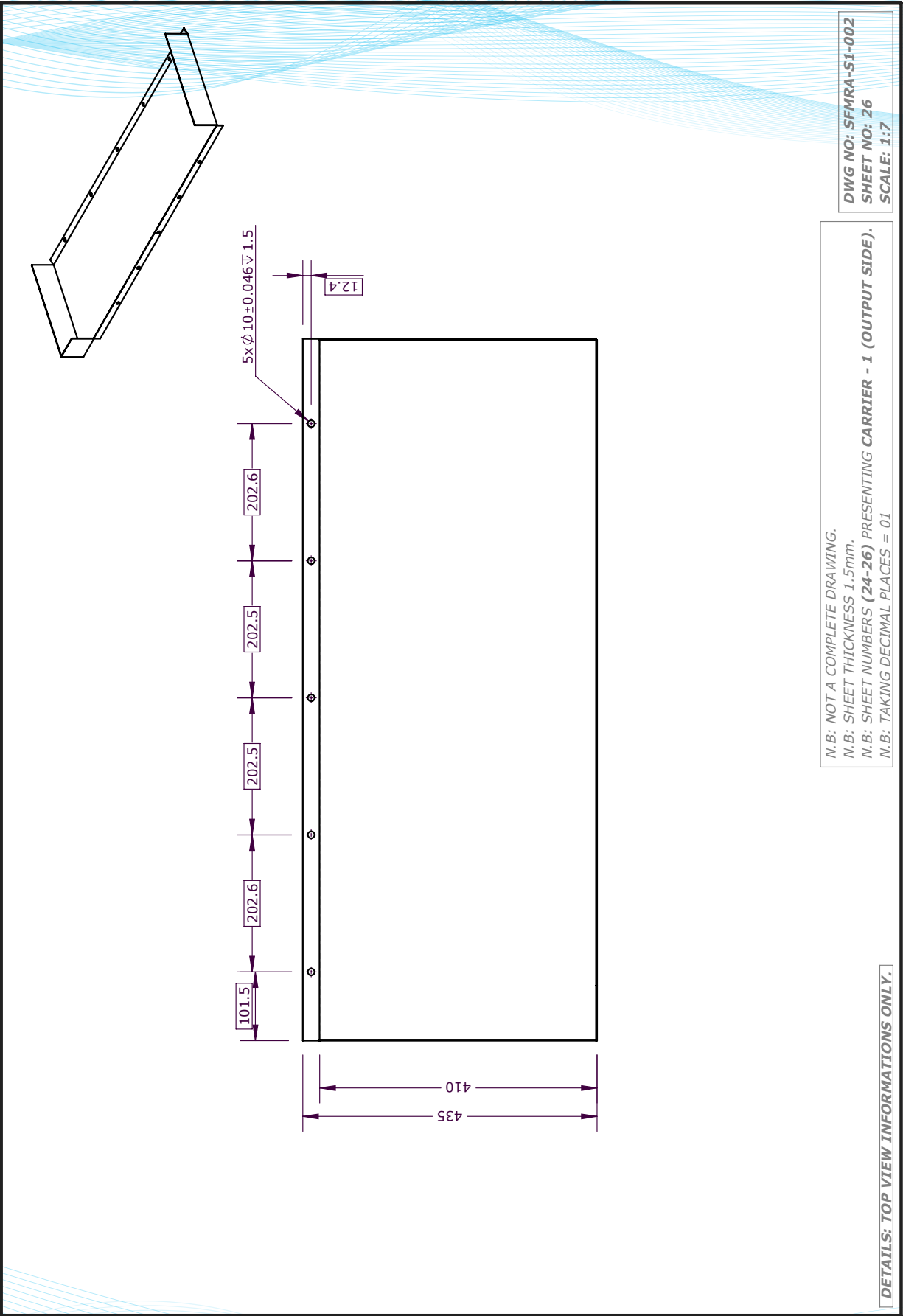

N.B.: NOT A COMPLETE DRAWING.
N.B.: SHEET THICKNESS 1.5mm.
N.B.: SHEET NUMBERS (24-26) PRESENTING CARRIER - 1 (OUTPUT SIDE).
N.B.: TAKING DECIMAL PLACES = 01



DWG NO: SFMRA-S1-002
SHEET NO: 26
SCALE: 1:7

DETAILS: TOP VIEW INFORMATIONS ONLY.

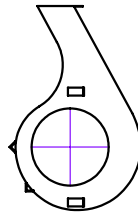
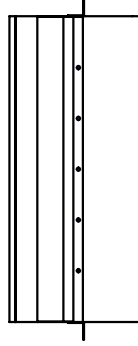
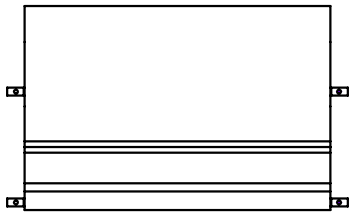
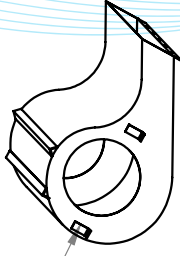
N.B: FLAT BAR (25x3)mm.
 TOTAL QUANTITY: 04 (ON BOTH SIDES).
 N.B: SHEET THICKNESS: 1.5mm

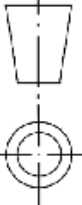

N.B: NOT A COMPLETE DRAWING.
 N.B: SHEET THICKNESS 1.5mm.
 N.B: SHEET NUMBERS (27-31) REPRESENTING BLOWER CASING.

UNLESS OTHERWISE SPECIFIED: STD. TOLERANCE DIMENSIONS ARE IN MILLIMETER MILLIMETER: ± 0.1, ANGULAR: ±0.05° * DOES NOT APPLY TO HOLE SIZE			BANGLADESH RICE RESEARCH INSTITUTE SFMRA PROJECT, FMPHT DIVISION		DO NOT SCALE DRAWING
			TITLE: BRRI RICE-WHEAT THRESHER (BRRI TH2023)		FINISH: NONE
DETAILS NAME DRAWN ENGR. SHAFTER JAHAN KHAN CHK'D DR. MD. MOSHARRAF HOSSAIN APP'VD DR. AKM SAIFUL ISLAM			SIGNATURE S J K M M H A S I	DATE 02-MAY-2024 18-MAY-2024 20-JULY-2024	FIRST ISSUED: 15-APR-2024
			THIRD ANGLE PROJECTION: 		
DRG. NO: SFMRA-S1-003 DRG. NAME: BLOWER_CASING MANUFACTURING METHOD: MACHINING, BENDING & WELDING MATERIAL: PLAIN CARBON STEEL SCALE: 1:20			WEIGHT: 23654.78 g SHEET: 27		REVISION: A

N.B: TAKING DECIMAL PLACES: 01

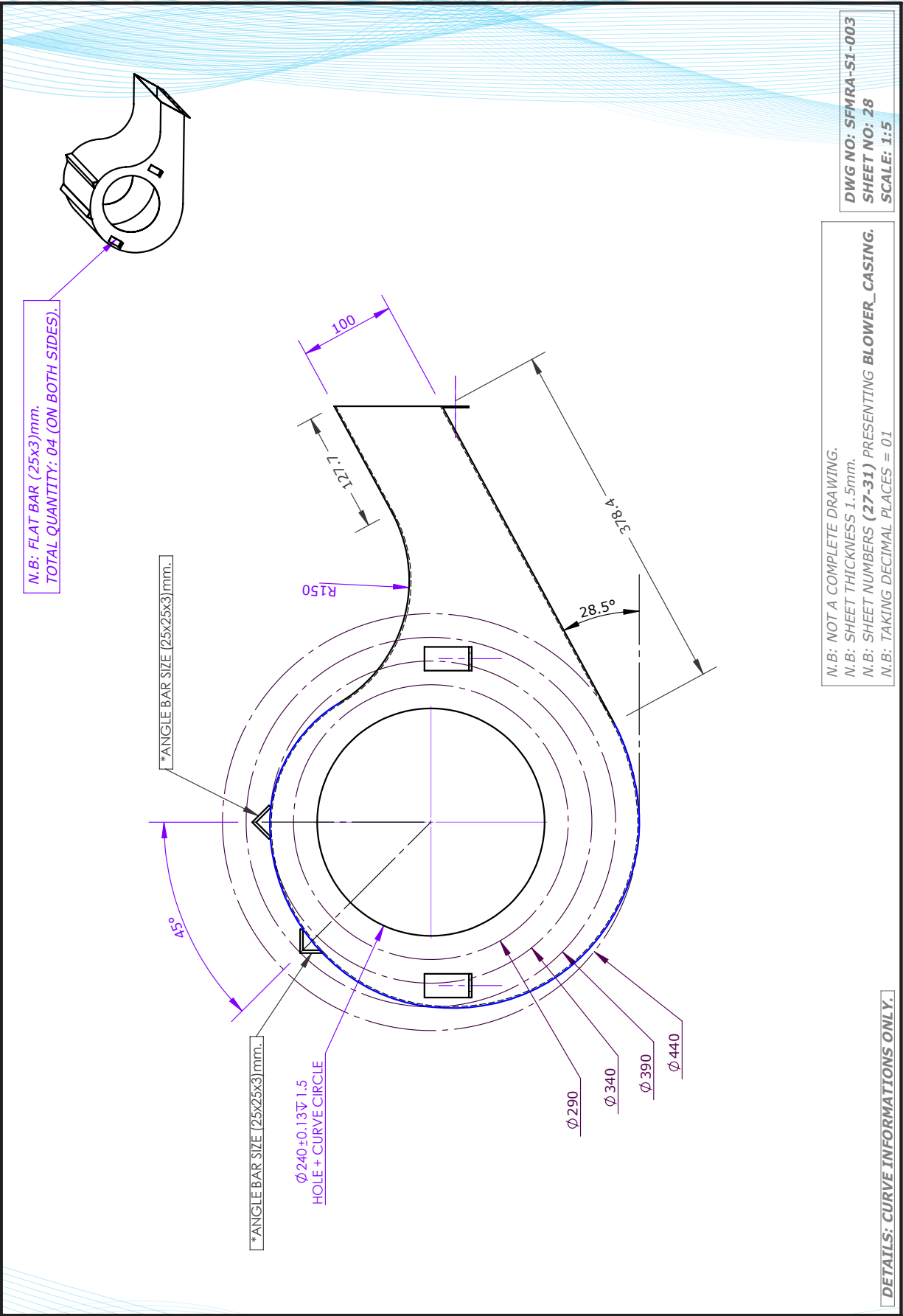

DWG NO: SFMRA-S1-003
SHEET NO: 28
SCALE: 1:5

N.B: NOT A COMPLETE DRAWING.
N.B: SHEET THICKNESS 1.5mm.
N.B: SHEET NUMBERS (27-31) REPRESENTING BLOWER_CASING.
N.B: TAKING DECIMAL PLACES = 01

DETAILS: CURVE INFORMATIONS ONLY.

N.B: FLAT BAR (25x3)mm.
TOTAL QUANTITY: 04 (ON BOTH SIDES).

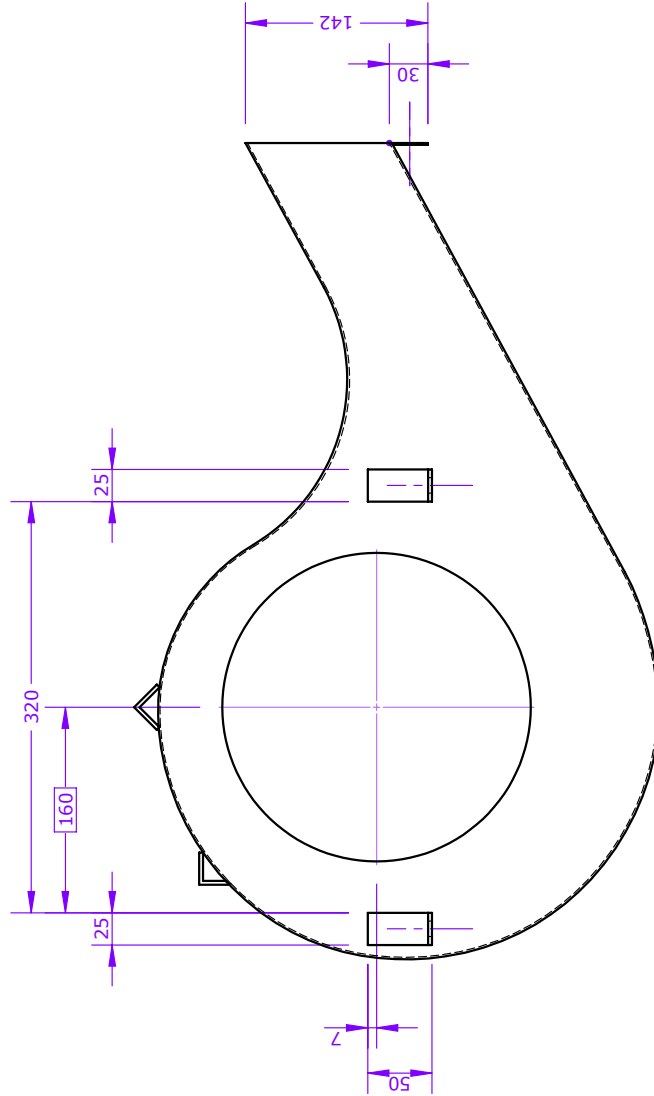
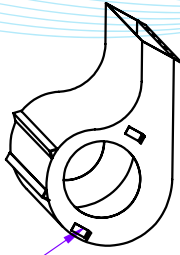

N.B: NOT A COMPLETE DRAWING.
N.B: SHEET THICKNESS 1.5mm.
N.B: SHEET NUMBERS (27-31) PRESENTING BLOWER_CASING.
N.B: TAKING DECIMAL PLACES = 01

DETAILS: FRONT VIEW INFORMATIONS ONLY.

DWG NO: SFMRA-S1-003
SHEET NO: 29
SCALE: 1:5

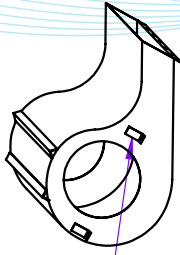

N.B: FLAT BAR (25x3)mm.
TOTAL QUANTITY: 04 (ON BOTH SIDES).

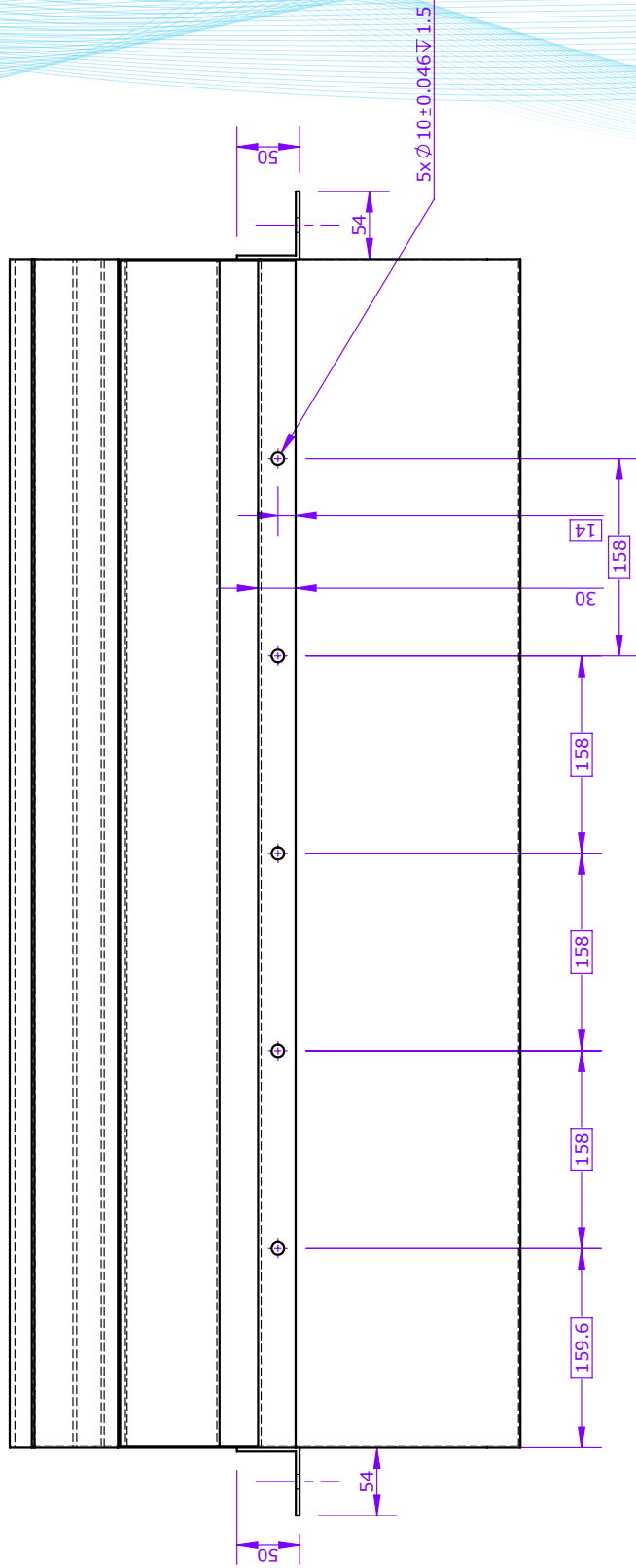

N.B.: NOT A COMPLETE DRAWING.
N.B.: SHEET THICKNESS 1.5mm.
N.B.: SHEET NUMBERS (27-31) PRESENTING BLOWER_CASING.
N.B.: TAKING DECIMAL PLACES = 01

DWG NO: SFMRA-S1-003
SHEET NO: 30
SCALE: 1:5

DETAILS: RIGHT VIEW INFORMATIONS ONLY.

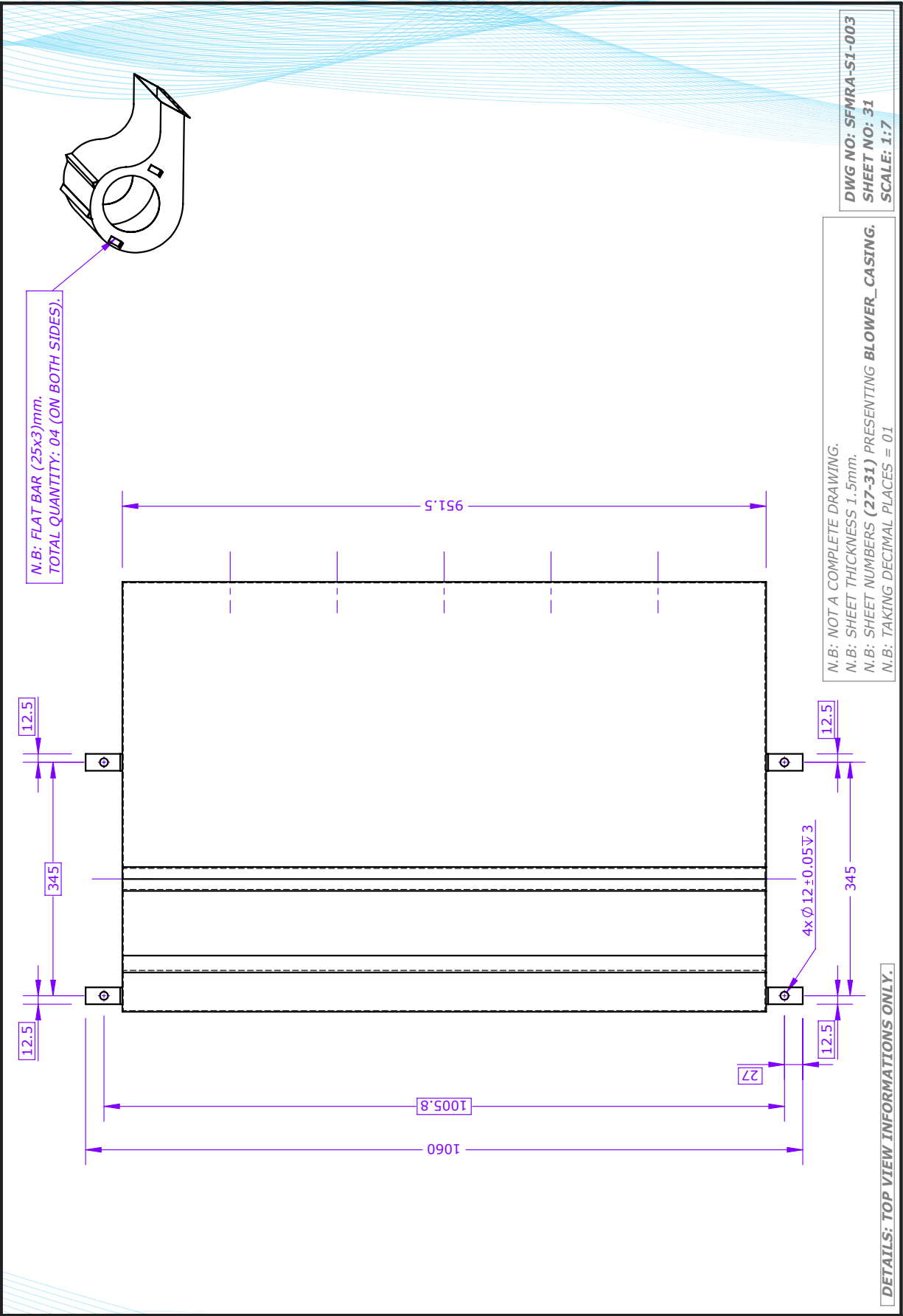

DWG NO: SFMRA-S1-003
 SHEET NO: 31
 SCALE: 1:7

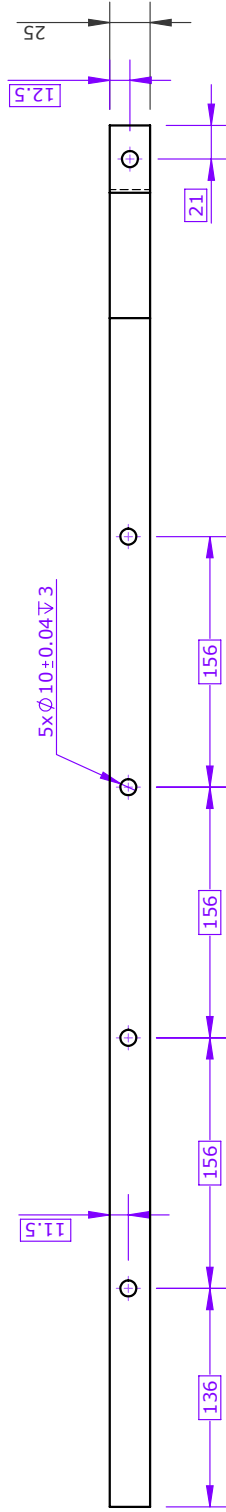
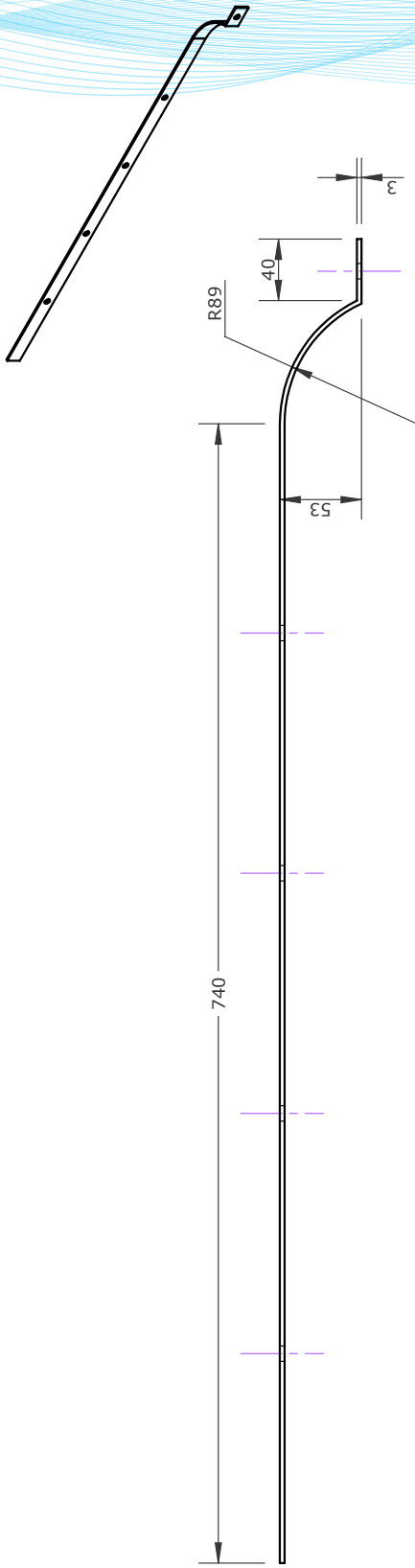

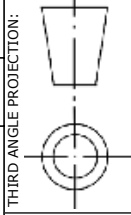
UNLESS OTHERWISE SPECIFIED: STD. TOLERANCE DIMENSIONS ARE IN MILLIMETER MILLIMETER: ± 0.1, ANGULAR: ±0.05° * DOES NOT APPLY TO HOLE SIZE				BANGLADESH RICE RESEARCH INSTITUTE SFMRA PROJECT, FMPHT DIVISION		DO NOT SCALE DRAWING FINISH: NONE FIRST ISSUED: 15-APR-2024	
DETAILS	NAME	SIGNATURE	DATE	TITLE: BRRI RICE-WHEAT THRESHER (BRRI TH2023)			
DRAWN	ENGR. SHAFFER JAHAN KHAN	S J K	02-MAY-2024	DRG. NAME: GUARD HOLDING PART			
CHK'D	DR. MD. MOSHARRAF HOSSAIN	M M H	18-MAY-2024	DWG NO: SFMRA-S1-005			
APP'VD	DR. AKM SAIFUL ISLAM	A S I	20-JULY-2024	MANUFACTURING METHOD: MACHINING, BENDING			
				MATERIAL: ASTM A36 STEEL			
SCALE: 1:4				WEIGHT: 508.64 g			
SHEET: 33				REVISION: A			

N.B: TAKING DECIMAL PLACES: 01

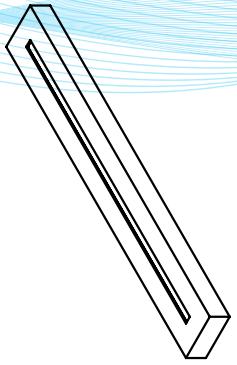
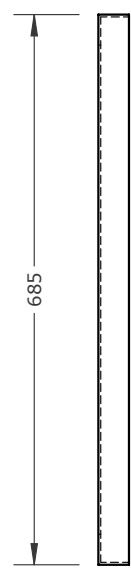
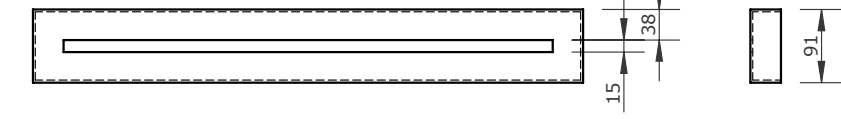



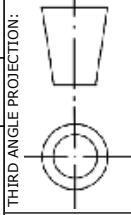

ANGLE BAR SIZE: (38x38x3)mm.

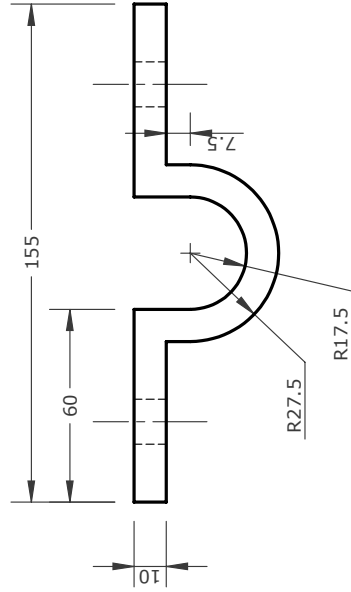
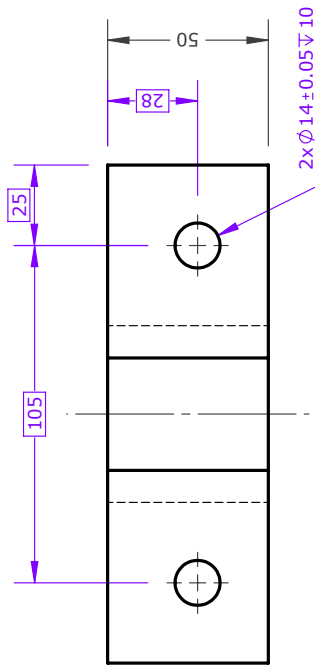
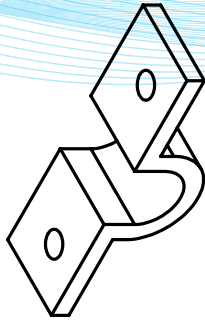
UNLESS OTHERWISE SPECIFIED: STD. TOLERANCE DIMENSIONS ARE IN MILLIMETER MILLIMETER: ± 0.1, ANGULAR: ±0.05° * DOES NOT APPLY TO HOLE SIZE			BANGLADESH RICE RESEARCH INSTITUTE		DO NOT SCALE DRAWING
			SFMRA PROJECT, FMPHT DIVISION		FINISH: NONE FIRST ISSUED: 15-APR-2024
DETAILS DRAWN ENGR. SHAFIET JAHAN KHAN CHK'D DR. MD. MOSHARRAF HOSSAIN APP'VD DR. AKM SAIFUL ISLAM			SIGNATURE	DATE	TITLE: BRRI RICE-WHEAT THRESHER (BRRI TH2023) DRG. NAME: ENGINE_CARRYING_FRAME DWG NO: SFMRA-S1-006
 THIRD ANGLE PROJECTION:			S J K 18-MAY-2024	M M H 20-JULY-2024	
				WEIGHT: 2522.20 g	A4
				SHEET: 34	REVISION: A



N.B: TAKING DECIMAL PLACES: 01

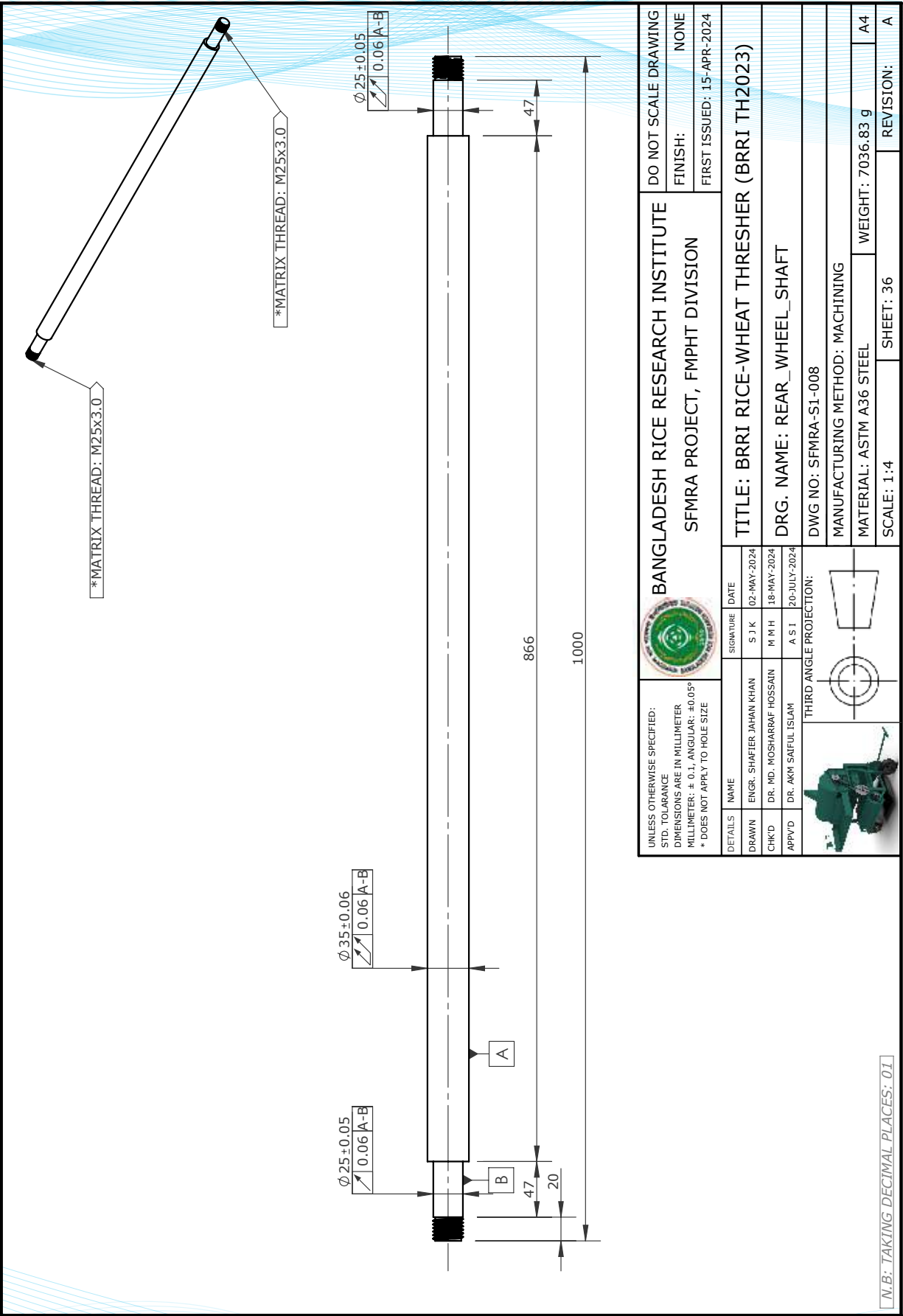

UNLESS OTHERWISE SPECIFIED: STD. TOLERANCE DIMENSIONS ARE IN MILLIMETER MILLIMETER: ± 0.1, ANGULAR: ±0.05° * DOES NOT APPLY TO HOLE SIZE				BANGLADESH RICE RESEARCH INSTITUTE SFMRA PROJECT, FMPHT DIVISION		DO NOT SCALE DRAWING	
DETAILS		NAME	SIGNATURE	DATE	FINISH: NONE		
DRAWN	ENGR. SHAFTER JAHAN KHAN	S J K		02-MAY-2024	FIRST ISSUED: 15-APR-2024		
CHK'D	DR. MD. MOSHARRAF HOSSAIN	M M H		18-MAY-2024	TITLE: BRRRI RICE-WHEAT THRESHER (BRRRI TH2023)		
APP'VD	DR. AKM SAIFUL ISLAM	A S I		20-JULY-2024	DRG. NAME: SHAFT HOLDER		
THIRD ANGLE PROJECTION:				DWG NO: SFMRA-S1-007			
				OUTSOURCING: VENDOR			
				MATERIAL: PLAIN CARBON STEEL		WEIGHT: 778.16 g	
				SCALE: 1:2		SHEET: 35	
						REVISION: A	

N.B: TAKING DECIMAL PLACES: 01

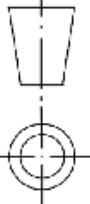

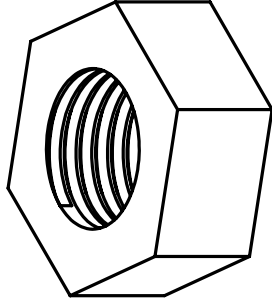

UNLESS OTHERWISE SPECIFIED: STD. TOLERANCE DIMENSIONS ARE IN MILLIMETER MILLIMETER: ± 0.1, ANGULAR: ±0.05° * DOES NOT APPLY TO HOLE SIZE				BANGLADESH RICE RESEARCH INSTITUTE SFMRA PROJECT, FMPHT DIVISION		DO NOT SCALE DRAWING	
DETAILS		NAME	SIGNATURE	DATE	FINISH: NONE		FIRST ISSUED: 15-APR-2024
DRAWN	ENGR. SHAFFER JAHAN KHAN	S J K	02-MAY-2024				
CHK'D	DR. MD. MOSHARRAF HOSSAIN	M M H	18-MAY-2024				
APP'VD	DR. AKM SAIFUL ISLAM	A S I	20-JULY-2024	TITLE: BRRRI RICE-WHEAT THRESHER (BRR TH2023) DRG. NAME: REAR_WHEEL_SHAFT			
THIRD ANGLE PROJECTION:				DWG NO: SFMRA-S1-008 MANUFACTURING METHOD: MACHINING			
				MATERIAL: ASTM A36 STEEL WEIGHT: 7036.83 g		SCALE: 1:4 SHEET: 36 REVISION: A	

N.B: TAKING DECIMAL PLACES: 01

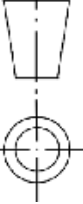

REAR WHEEL AXLE LOCK NUT
 SIZE: **M25x3.0**
 QUANTITY: 02

UNLESS OTHERWISE SPECIFIED: STD. TOLERANCE DIMENSIONS ARE IN MILLIMETER MILLIMETER: ± 0.1, ANGULAR: ±0.05° * DOES NOT APPLY TO HOLE SIZE			BANGLADESH RICE RESEARCH INSTITUTE SFMRA PROJECT, FMPHT DIVISION		DO NOT SCALE DRAWING
			TITLE: BRRI RICE-WHEAT THRESHER (BRRI TH2023) DRG. NAME: NUT_M25_FOR_REAR_WHEEL_SHAFT		FINISH: NONE FIRST ISSUED: 15-APR-2024
DETAILS	NAME	SIGNATURE	DATE		
DRAWN	ENGR. SHAFIET JAHAN KHAN	S J K	02-MAY-2024		
CHK'D	DR. MD. MOSHARRAF HOSSAIN	M M H	18-MAY-2024		
APP'VD	DR. AKM SAIFUL ISLAM	A S I	20-JULY-2024		
			THIRD ANGLE PROJECTION: 		
DWG NO: SFMRA-S1-009 OUTSOURCING: VENDOR MATERIAL: STAINLESS STEEL (FERRITIC) SCALE: 1:1			WEIGHT: N/A g SHEET: 37 REVISION: A		

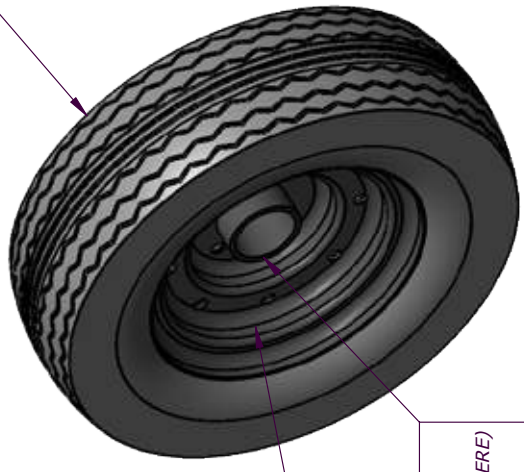

N.B: TAKING DECIMAL PLACES: 01

TIRE: 4.00-8 TIRE
 Dimensions: Dia x Width 408mm x 118mm
 Rim Size: **8"**
 Max Load: **265kg**
 Max Pressure: **4.1bar 59psi**
 QUANTITY: **03**



RIM: RIM FOR 4.00-8 TIRE
 QUANTITY: **03**
 *****LOCALLY MADE.**

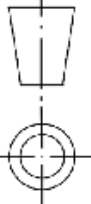

RIM LOCKER
 INNER DIA: **52mm**
 (THE BEARING 6205, WILL PLACE HERE)
 HOLE DIA: **11mm**
 HOLE NUMBER: **04**
 PATTERN: **CIRCULAR**
 QUANTITY: **03**
 *****LOCALLY MADE.**

UNLESS OTHERWISE SPECIFIED: STD. TOLERANCE DIMENSIONS ARE IN MILLIMETER MILLIMETER: ± 0.1, ANGULAR: ±0.05° * DOES NOT APPLY TO HOLE SIZE			BANGLADESH RICE RESEARCH INSTITUTE		DO NOT SCALE DRAWING	
			SFMRA PROJECT, FMPHT DIVISION		FINISH: <input type="checkbox"/> NONE	FIRST ISSUED: 15-APR-2024
DETAILS			NAME	SIGNATURE	DATE	TITLE: BRRI RICE-WHEAT THRESHER (BRRI TH2023) DRG. NAME: WHEEL_AND_RIM_FOR_4.00-8-TIRE DWG NO: SFMRAS1-010 OUTSOURCING: VENDOR MATERIAL: N/A WEIGHT: N/A SCALE: 1:5 SHEET: 38 REVISION: A
DRAWN	ENGR. SHAFTER JAHAN KHAN	S J K	02-MAY-2024			
CHK'D	DR. MD. MOSHARRAF HOSSAIN	M M H	18-MAY-2024			
APP'VD	DR. AKM SAIFUL ISLAM	A S I	20-JULY-2024			
THIRD ANGLE PROJECTION:						

N.B: TAKING DECIMAL PLACES: 01

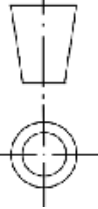

BALL BEARING: **6205**
 INNER DIA: 25mm
 OUTER DIA: 52mm
 QUANTITY: 06 (FOR WHEELS)

UNLESS OTHERWISE SPECIFIED: STD. TOLERANCE DIMENSIONS ARE IN MILLIMETER MILLIMETER: ± 0.1, ANGULAR: ±0.05° * DOES NOT APPLY TO HOLE SIZE			BANGLADESH RICE RESEARCH INSTITUTE		DO NOT SCALE DRAWING	
			SFMRA PROJECT, FMPHT DIVISION		FINISH: NONE FIRST ISSUED: 15-APR-2024	
DETAILS			SIGNATURE	DATE	TITLE: BRRRI RICE-WHEAT THRESHER (BRRRI TH2023)	
DRAWN	ENGR. SHAFFER JAHAN KHAN	S J K	02-MAY-2024	DRG. NAME: 6205_RS_BEARING		
CHK'D	DR. MD. MOSHARRAF HOSSAIN	M M H	18-MAY-2024	DWG NO: SFMRA-S1-011		
APP'VD	DR. AKM SAIFUL ISLAM	A S I	20-JULY-2024	OUTSOURCING: VENDOR		
THIRD ANGLE PROJECTION:						
			MATERIAL: N/A		WEIGHT: N/A	A4
SCALE: 1:1			SHEET: 39		REVISION: A	

N.B: TAKING DECIMAL PLACES: 01

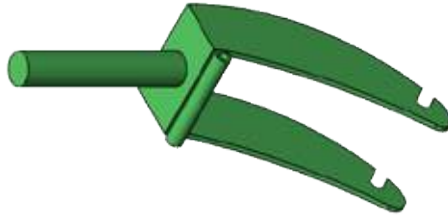





NAME: **FRONT WHEEL CARRYING FRAME**
 MADE BY: LOCAL MANUFACTURERS
 WHEEL DIA: **400mm**
 THICKNESS: **8mm**
 UPPER PIPE DIA: **36mm**
 *(35-40)mm DIA IS ACCEPTED.

UNLESS OTHERWISE SPECIFIED: STD. TOLERANCE DIMENSIONS ARE IN MILLIMETER MILLIMETER: ± 0.1, ANGULAR: ±0.05° * DOES NOT APPLY TO HOLE SIZE			BANGLADESH RICE RESEARCH INSTITUTE		DO NOT SCALE DRAWING
			SFMRA PROJECT, FMPHT DIVISION		
TITLE: BRRRI RICE-WHEAT THRESHER (BRRRI TH2023) DRG. NAME: FRONT_WHEEL_SUPPORT					
DWG NO: SFMRA-S1-012					
OUTSOURCING: VENDOR					
MATERIAL: N/A			WEIGHT: N/A		
SCALE: 1:8			SHEET: 40		
REVISION: A					

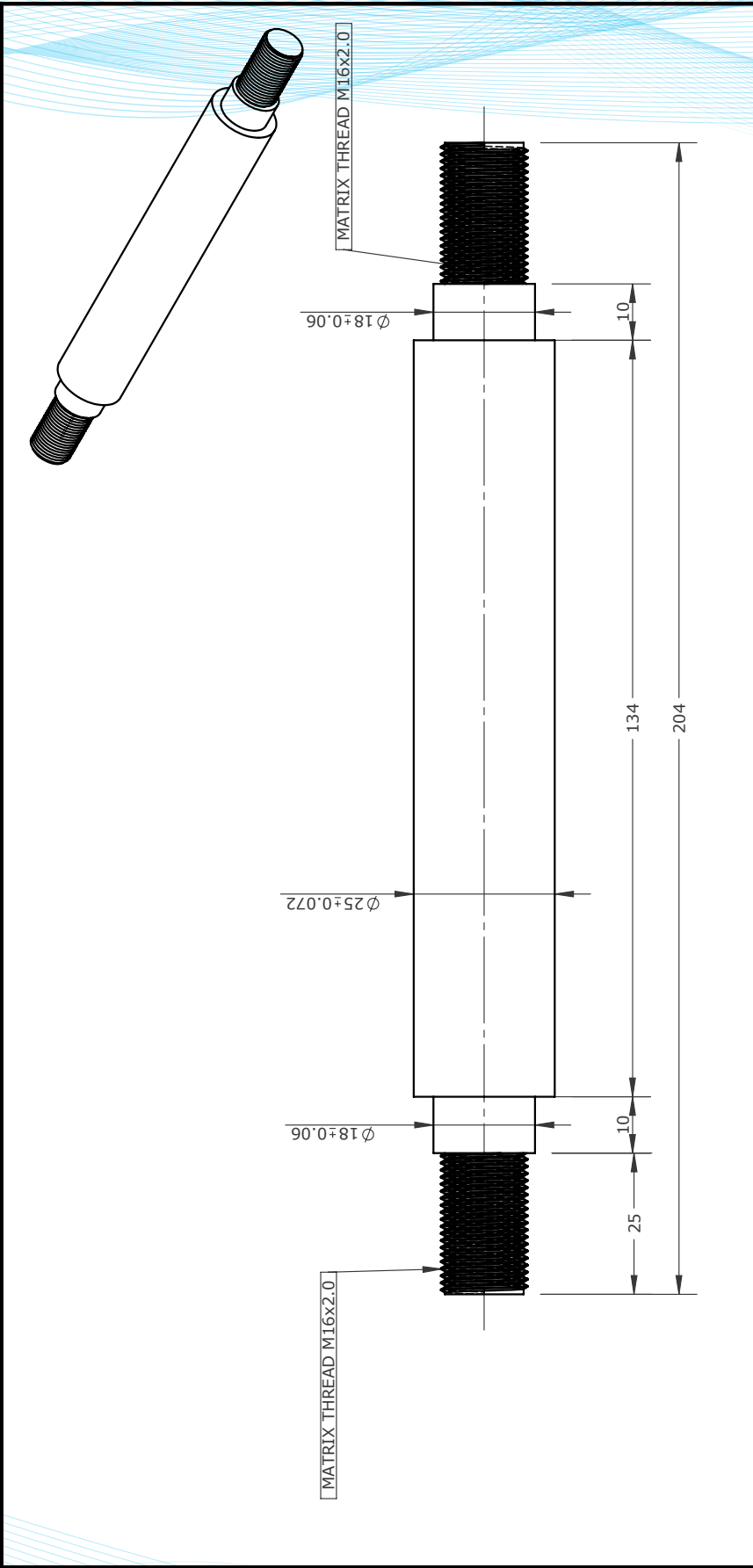

N.B: TAKING DECIMAL PLACES: 01

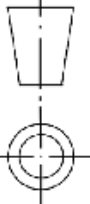

UNLESS OTHERWISE SPECIFIED: STD. TOLERANCE DIMENSIONS ARE IN MILLIMETER MILLIMETER: ± 0.1 , ANGULAR: $\pm 0.05^\circ$ * DOES NOT APPLY TO HOLE SIZE		 BANGLADESH RICE RESEARCH INSTITUTE SFMRA PROJECT, FMPHT DIVISION		DO NOT SCALE DRAWING	
DETAILS		SIGNATURE	DATE	FINISH:	NONE
DRAWN	ENGR. SHAFTER JAHAN KHAN	S J K	02-MAY-2024	FIRST ISSUED:	15-APR-2024
CHK'D	DR. MD. MOSHARRAF HOSSAIN	M M H	18-MAY-2024	TITLE: BRRRI RICE-WHEAT THRESHER (BRRITH2023)	
APP'VD	DR. AKM SAIFUL ISLAM	A S I	20-JULY-2024	DRG. NAME: SHAFT_FOR_FRONT_WHEEL	
THIRD ANGLE PROJECTION:					
		DWG NO: SFMRA-S1-013			
MANUFACTURING METHOD: MACHINING					
MATERIAL: ASTM A36 STEEL				WEIGHT: 621.92 g	
SCALE: 1:1				SHEET: 41	
				REVISION: A	

N.B: TAKING DECIMAL PLACES: 01

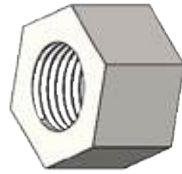

NUT: **M16x2.0**
 QUANTITY: 02
 ***FRONT WHEEL AXLE LOCK NUT.

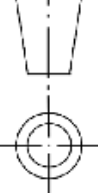
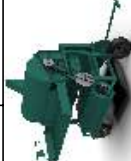

UNLESS OTHERWISE SPECIFIED: STD. TOLERANCE DIMENSIONS ARE IN MILLIMETER MILLIMETER: ± 0.1, ANGULAR: ±0.05° * DOES NOT APPLY TO HOLE SIZE				BANGLADESH RICE RESEARCH INSTITUTE SFMRA PROJECT, FMPHT DIVISION		DO NOT SCALE DRAWING	
DETAILS		NAME	SIGNATURE	DATE	TITLE: BRRRI RICE-WHEAT THRESHER (BRRRI TH2023)		
DRAWN	ENGR. SHAFTER JAHAN KHAN	S J K	[Signature]	02-MAY-2024	DRG. NAME: WHEEL_NUT_M16_(FRONT-X2)		
CHK'D	DR. MD. MOSHARRAF HOSSAIN	M M H	[Signature]	18-MAY-2024	DWG NO: SFMRA-S1-014		
APP'VD	DR. AKM SAIFUL ISLAM	A S I	[Signature]	20-JULY-2024	OUTSOURCING: VENDOR		
THIRD ANGLE PROJECTION:				MATERIAL: SS			
		SCALE: 1:1		SHEET: 42		REVISION: A	

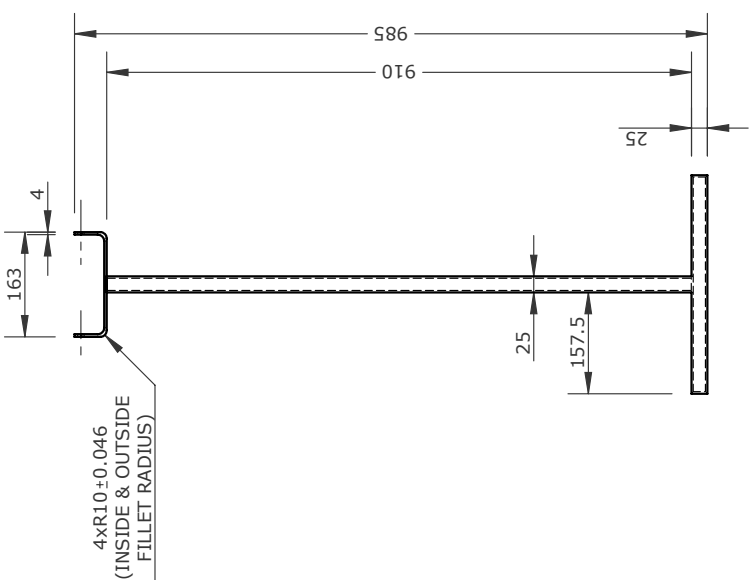
N.B: TAKING DECIMAL PLACES: 01



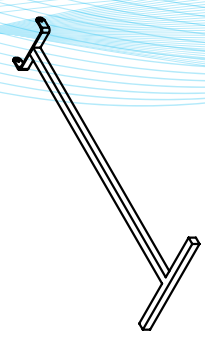
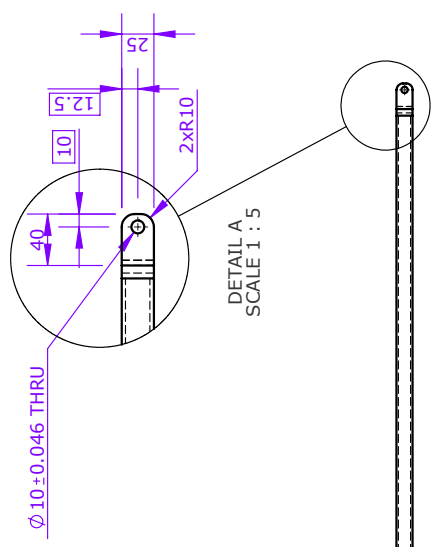

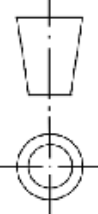

N.B: (25x25x3)mm SQUARE TUBE.

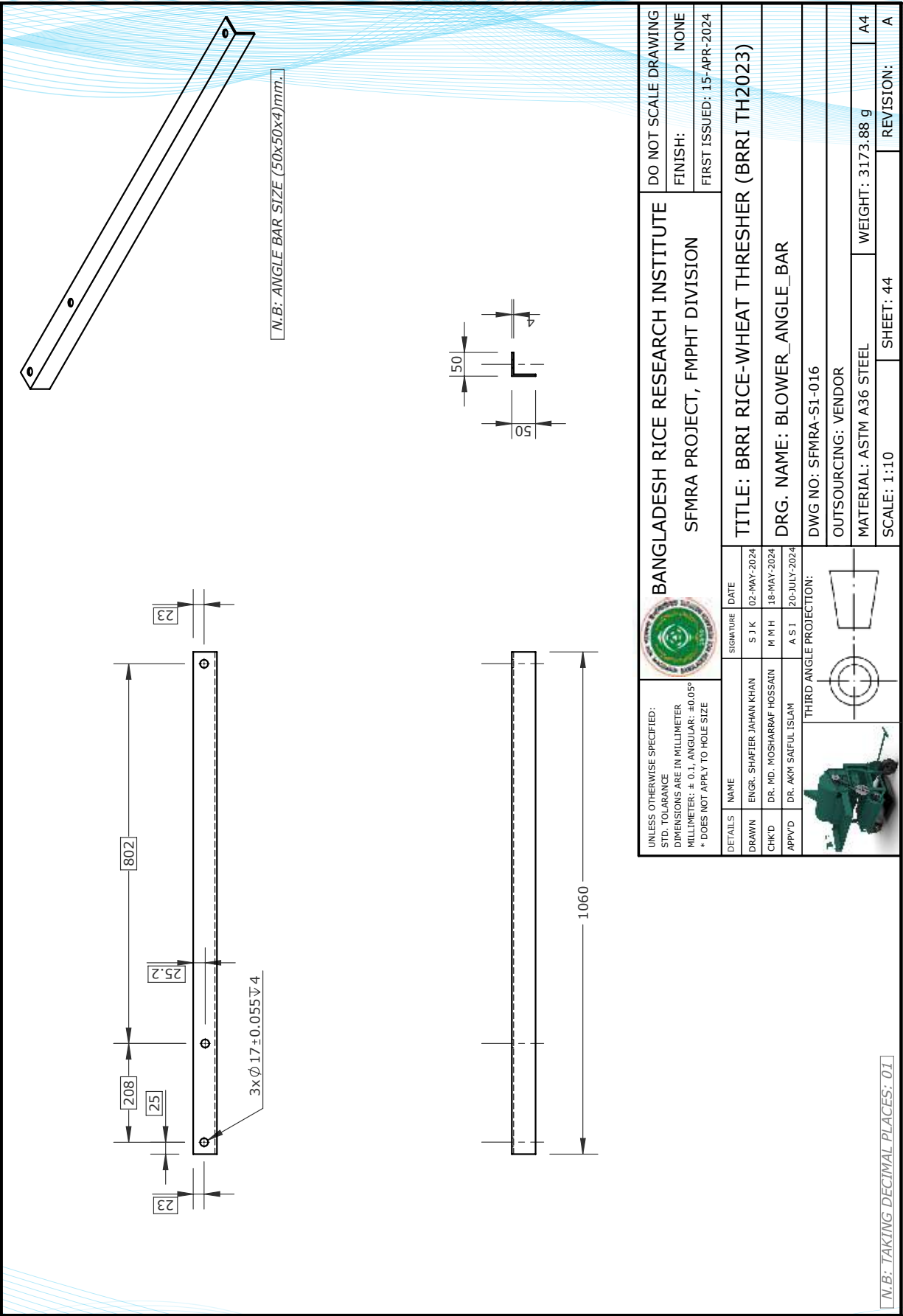

UNLESS OTHERWISE SPECIFIED: STD. TOLERANCE DIMENSIONS ARE IN MILLIMETER MILLIMETER: ± 0.1, ANGULAR: ±0.05° * DOES NOT APPLY TO HOLE SIZE		 BANGLADESH RICE RESEARCH INSTITUTE SFMRA PROJECT, FMPHT DIVISION		DO NOT SCALE DRAWING
DETAILS		SIGNATURE	DATE	FINISH: NONE
DRAWN	ENGR. SHAFFER JAHAN KHAN	S J K	02-MAY-2024	FIRST ISSUED: 15-APR-2024
CHK'D	DR. MD. MOSHARRAF HOSSAIN	M M H	18-MAY-2024	
APP'VD	DR. AKM SAIFUL ISLAM	A S I	20-JULY-2024	
THIRD ANGLE PROJECTION:		TITLE: BRRRI RICE-WHEAT THRESHER (BRRRI TH2023)		
		DRG. NAME: BASE_HANDLE		
		DWG NO: SFMRA-S1-015		
		OUTSOURCING: VENDOR		
		MATERIAL: ASTM A36 STEEL		
		SCALE: 1:10		
		WEIGHT: 2800.05 g		
		SHEET: 43		
		REVISION: A		

N.B: TAKING DECIMAL PLACES: 01

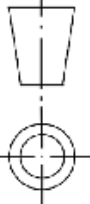

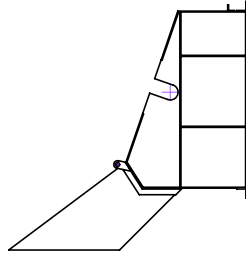
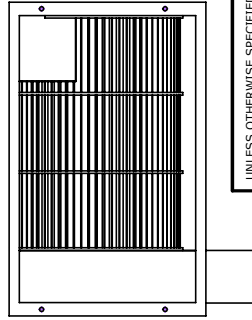
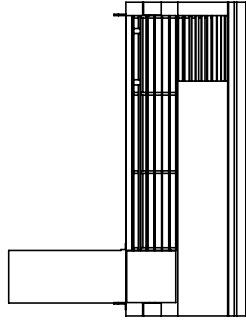
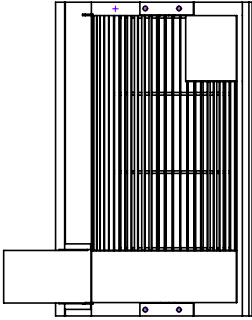
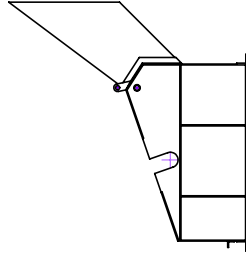
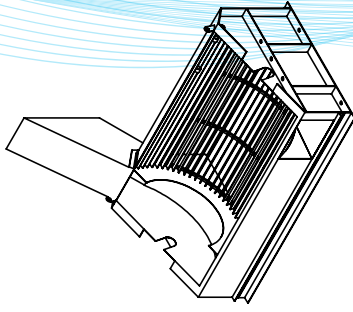

UNLESS OTHERWISE SPECIFIED: STD. TOLERANCE DIMENSIONS ARE IN MILLIMETER MILLIMETER: ± 0.1, ANGULAR: ±0.05° * DOES NOT APPLY TO HOLE SIZE				BANGLADESH RICE RESEARCH INSTITUTE SFMRA PROJECT, FMPHT DIVISION		DO NOT SCALE DRAWING FINISH: NONE FIRST ISSUED: 15-APR-2024	
DETAILS	NAME	SIGNATURE	DATE	TITLE: BRRRI RICE-WHEAT THRESHER (BRRITH2023)			
DRAWN	ENGR. SHAFFER JAHAN KHAN	S J K	02-MAY-2024	DRG. NAME: BLOWER_ANGLE_BAR			
CHK'D	DR. MD. MOSHARRAF HOSSAIN	M M H	18-MAY-2024	DWG NO: SFMRA-S1-016			
APP'VD	DR. AKM SAIFUL ISLAM	A S I	20-JULY-2024	OUTSOURCING: VENDOR			
THIRD ANGLE PROJECTION:							
				MATERIAL: ASTM A36 STEEL WEIGHT: 3173.88 g		SCALE: 1:10 SHEET: 44	
						REVISION: A	

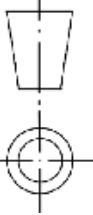

N.B: NOT A COMPLETE DRAWING.

N.B: SHEET (45-53) PRESENTING THRESHING DRUM CASING.

UNLESS OTHERWISE SPECIFIED: STD. TOLERANCE DIMENSIONS ARE IN MILLIMETER MILLIMETER: ± 0.1, ANGULAR: ±0.05° * DOES NOT APPLY TO HOLE SIZE				BANGLADESH RICE RESEARCH INSTITUTE SFMR PROJECT, FMPHT DIVISION		DO NOT SCALE DRAWING FINISH: NONE FIRST ISSUED: 15-APR-2024	
DETAILS	NAME	SIGNATURE	DATE	TITLE: BRRI RICE-WHEAT THRESHER (BRRI TH2023)			
DRAWN	ENGR. SHAFTER JAHAN KHAN	S J K	08-MAY-2024	DRG. NAME: THRESHING_DRUM_CASING			
CHK'D	DR. MD. MOSHARRAF HOSSAIN	M M H	18-MAY-2024	DWG NO: SFMRA-S2-017			
APP'VD	DR. AKM SAIFUL ISLAM	A S I	20-JULY-2024	MANUFACTURING METHOD: MACHINING, BENDING & WELDING			
THIRD ANGLE PROJECTION:							
				MATERIAL: PLAIN CARBON STEEL WEIGHT: 59333.96 g			
SCALE: 1:25 SHEET: 45				REVISION: A			

N.B: TAKING DECIMAL PLACES: 01

NO.	DETAILS	SIZE (mm)
1.	SHEET THICKNESS	1.5
2.	ANGLE BAR	25x25x3
3.	ANGLE BAR	38x38x3
4.	FLAT BAR	25x3
5.	FLAT BAR	30x5
6.	FLAT BAR	50x4
7.	SQUARE BAR	10x10
8.	CIRCULAR PIPE (INNER DIA=ID & OUTER DIA=OD)	ID = 19 OD = 25

N.B: NOT A COMPLETE DRAWING.
SHEET NUMBERS (45-53) ARE DWG NO. SFMRA-S2-017
DETAILS: ISOMETRIC VIEW INFORMATIONS ONLY.

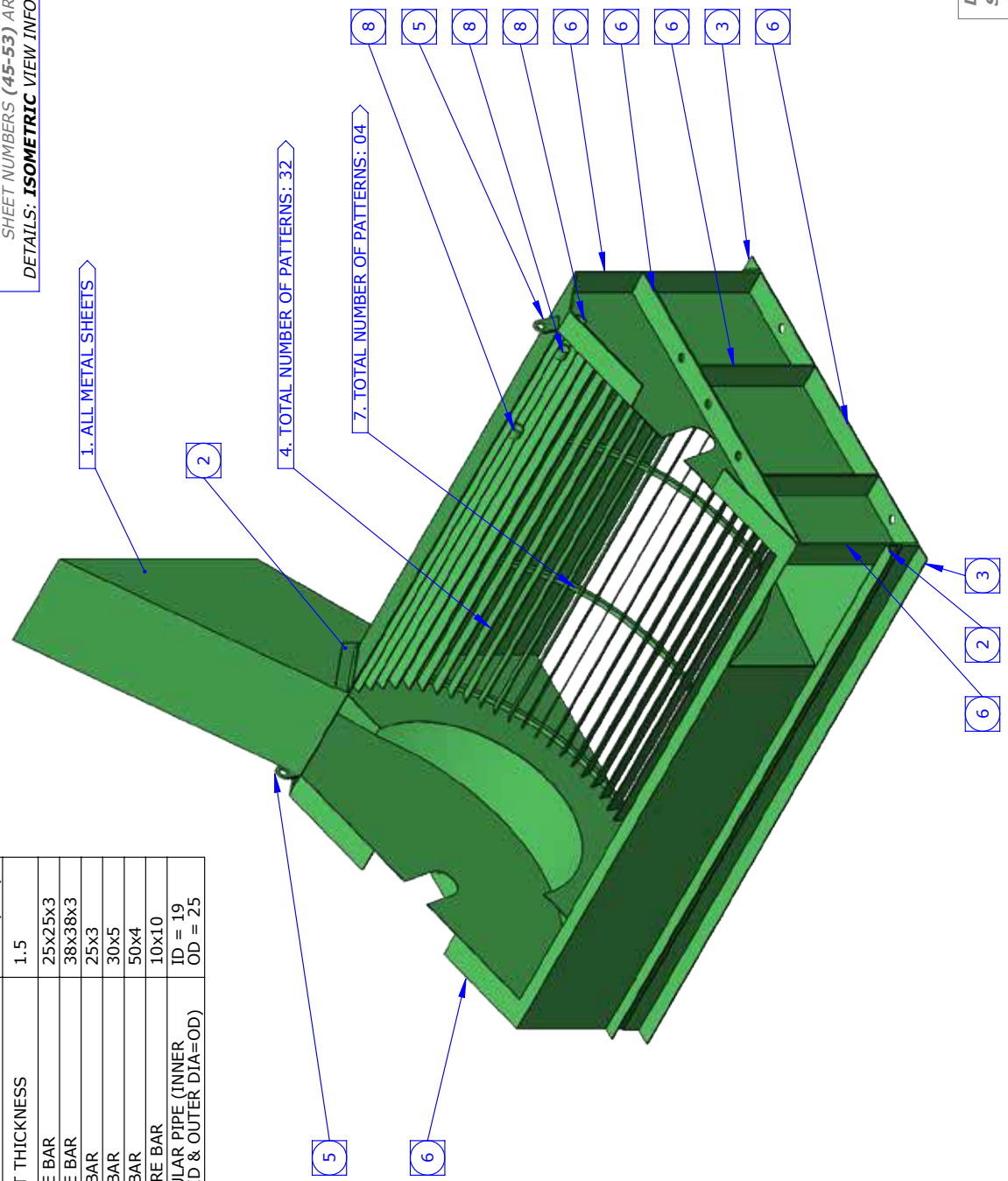

DWG NO: SFMRA-S2-017
SHEET NO: 46
SCALE: 1:10

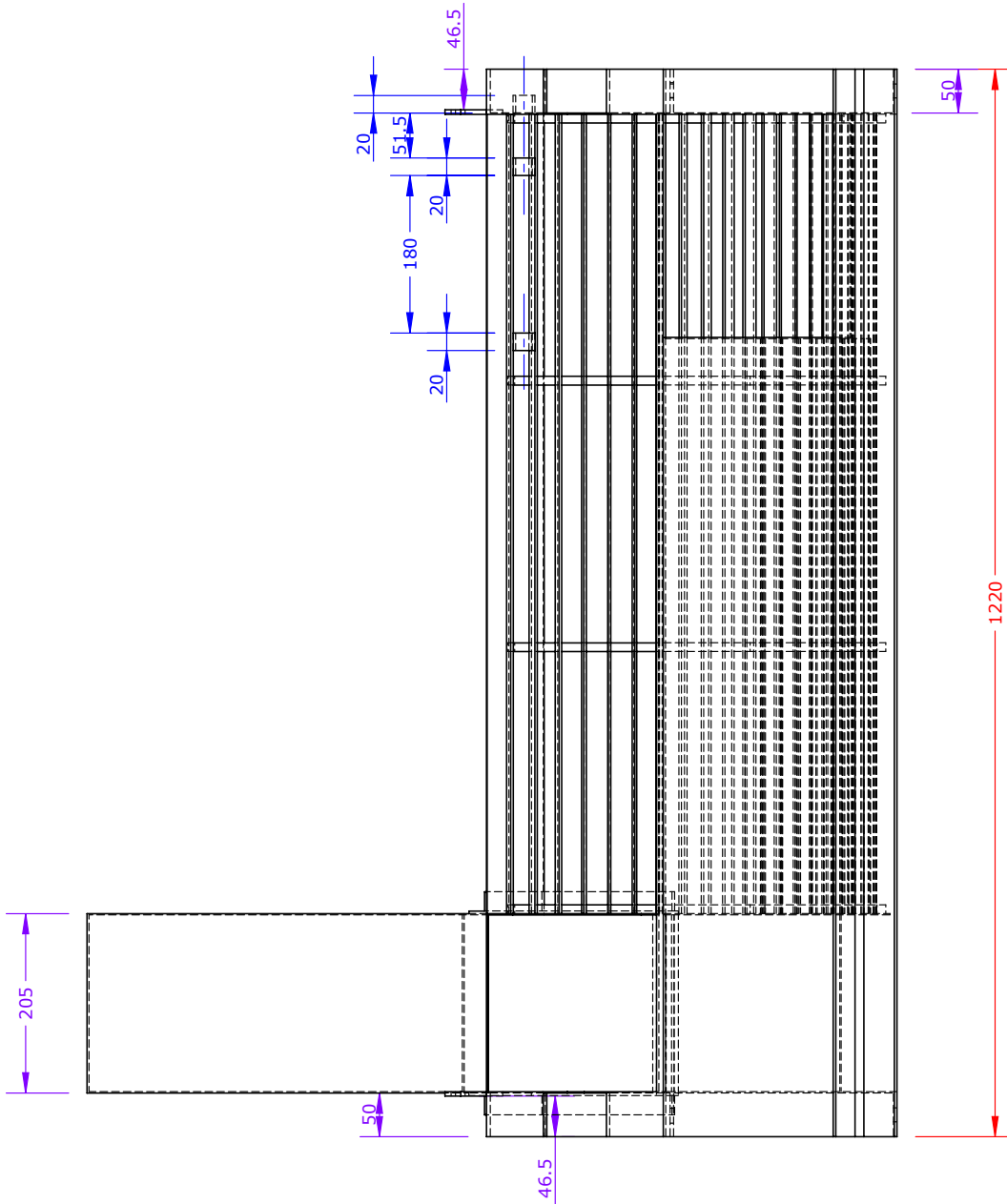
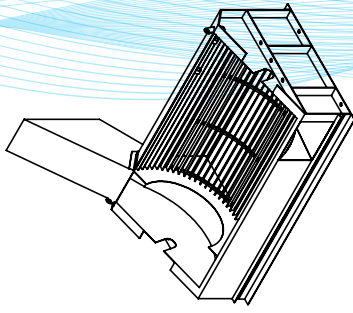

N.B: NOT A COMPLETE DRAWING.
N.B: SHEET THICKNESS 1.5mm.
N.B: SHEET NUMBERS (45-53) PRESENTING THRESHING_DRUM_CASING.
N.B: TAKING DECIMAL PLACES = 01

DWG NO: SFMRA-S2-017
SHEET NO: 47
SCALE: 1:7

DETAILS: FRONT VIEW INFORMATIONS ONLY.

N.B: NOT A COMPLETE DRAWING.
 N.B: SHEET NUMBERS (45-53) PRESENTING THRESHING_DRUM_CASING.
 N.B: RIGHT VIEW (WITHOUT ANGLE) INFORMATIONS ONLY.
 N.B: TAKING DECIMAL PLACES = 01
 N.B: VARIOUS COLORS USED FOR BETTER UNDERSTANDING ONLY.

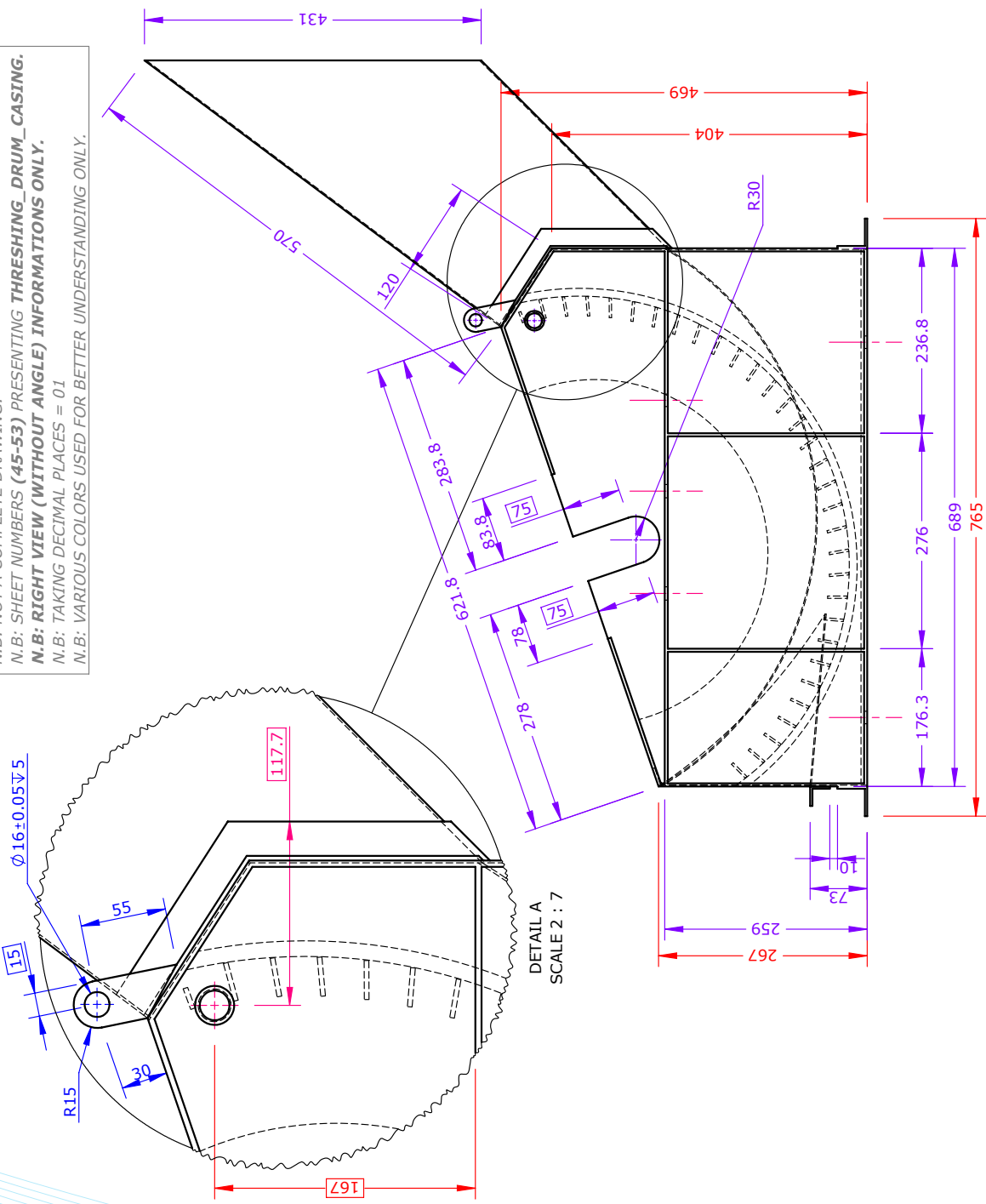
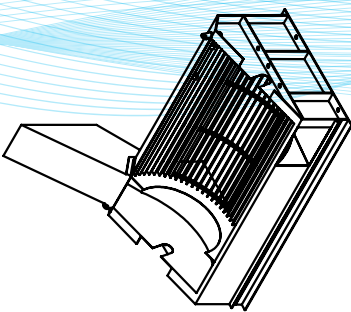

DWG NO: SFMRA-S2-017
 SHEET NO: 48
 SCALE: 1:7

N.B: NOT A COMPLETE DRAWING.
 N.B: SHEET NUMBERS (45-53) PRESENTING **THRESHING_DRUM_CASING**.
 N.B: **RIGHT VIEW (ONLY ANGLE) INFORMATIONS ONLY**.
 N.B: TAKING DECIMAL PLACES = 01
 N.B: VARIOUS COLORS USED FOR BETTER UNDERSTANDING ONLY.

N.B: CHECK SHEET NUMBER 42.
 N.B: CHECK ROW NUMBER 02 FROM THE TABLE.
 N.B: ANGLE BARS WAS WELDED HERE.

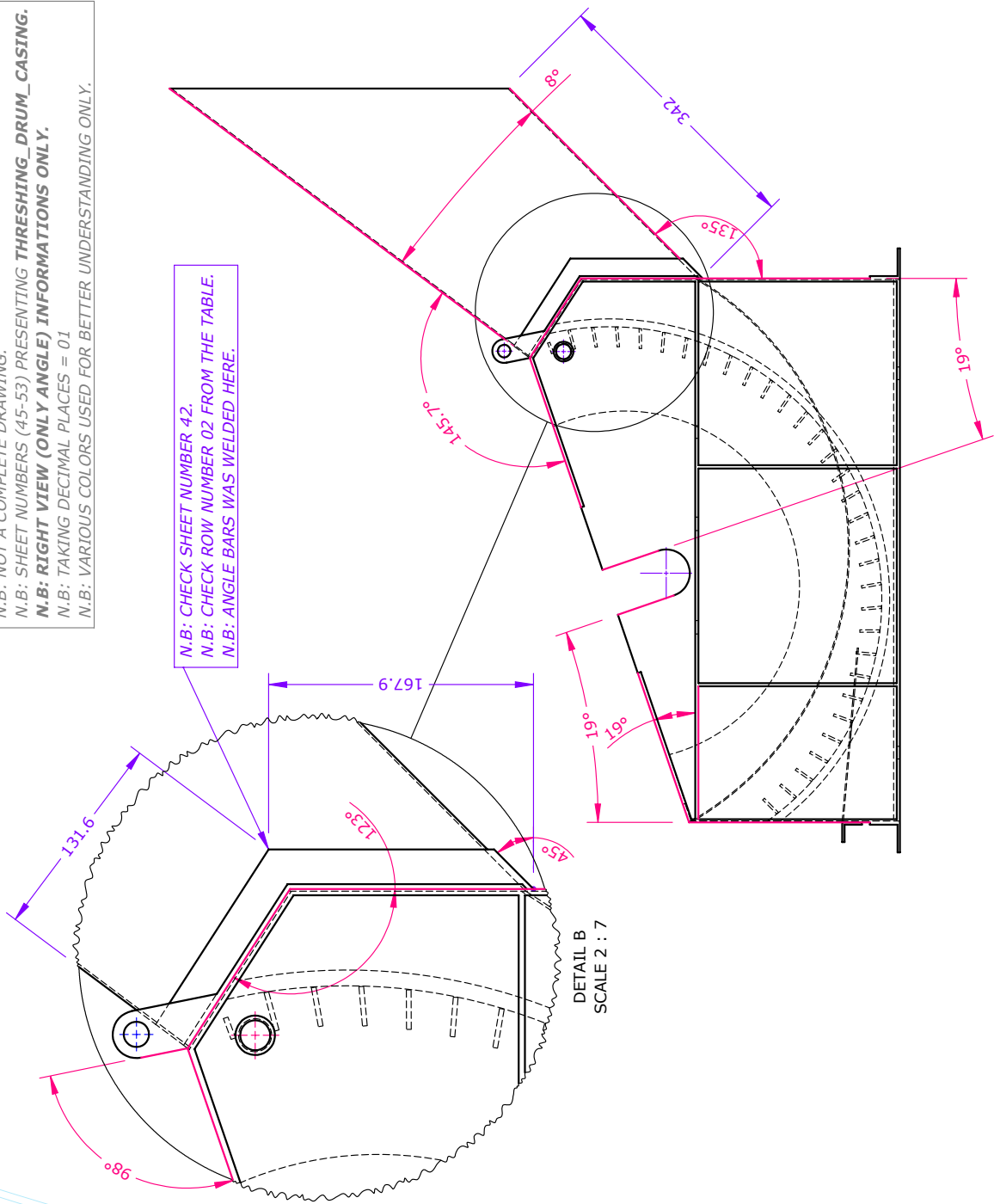

DWG NO: SFMRA-S2-017
 SHEET NO: 49
 SCALE: 1:7

N.B.: NOT A COMPLETE DRAWING. HOLES ARE SYMMETRY FOR THIS VIEW.
 N.B.: SHEET NUMBERS (45-53) PRESENTING **THRESHING_DRUM_CASING**.
 N.B.: **TOP** VIEW INFORMATIONS ONLY.
 N.B.: TAKING DECIMAL PLACES = 01
 N.B.: VARIOUS COLORS USED FOR BETTER UNDERSTANDING ONLY.

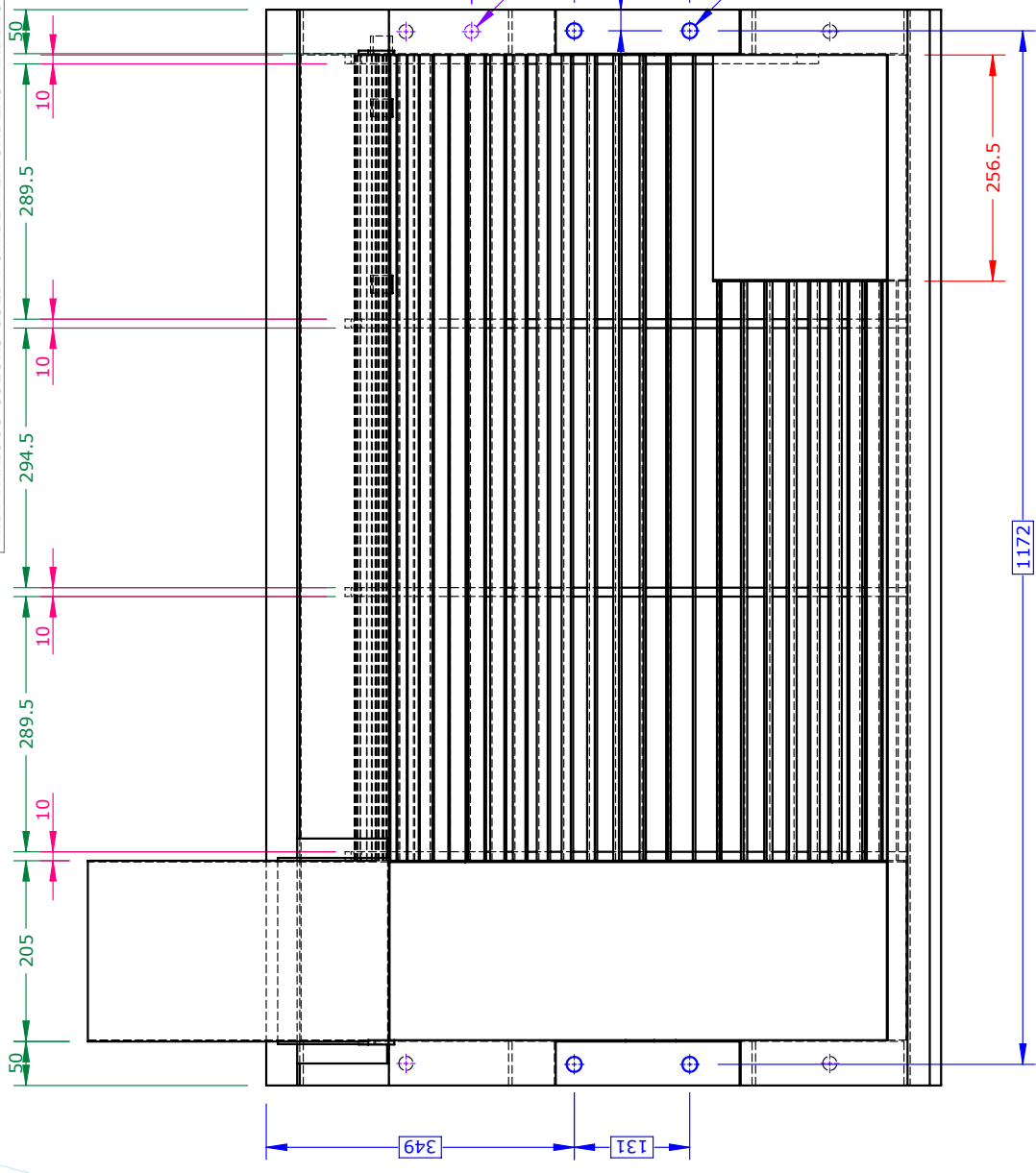

N.B.: HOLE DIMENSIONS FOR THIS FACE HAS SHOWN ONLY.
 N.B.: BEARING HOUSING HOLE DIMENSIONS ARE SYMMETRY.

DWG NO: SFMRA-S2-017
 SHEET NO: 50
 SCALE: 1:7

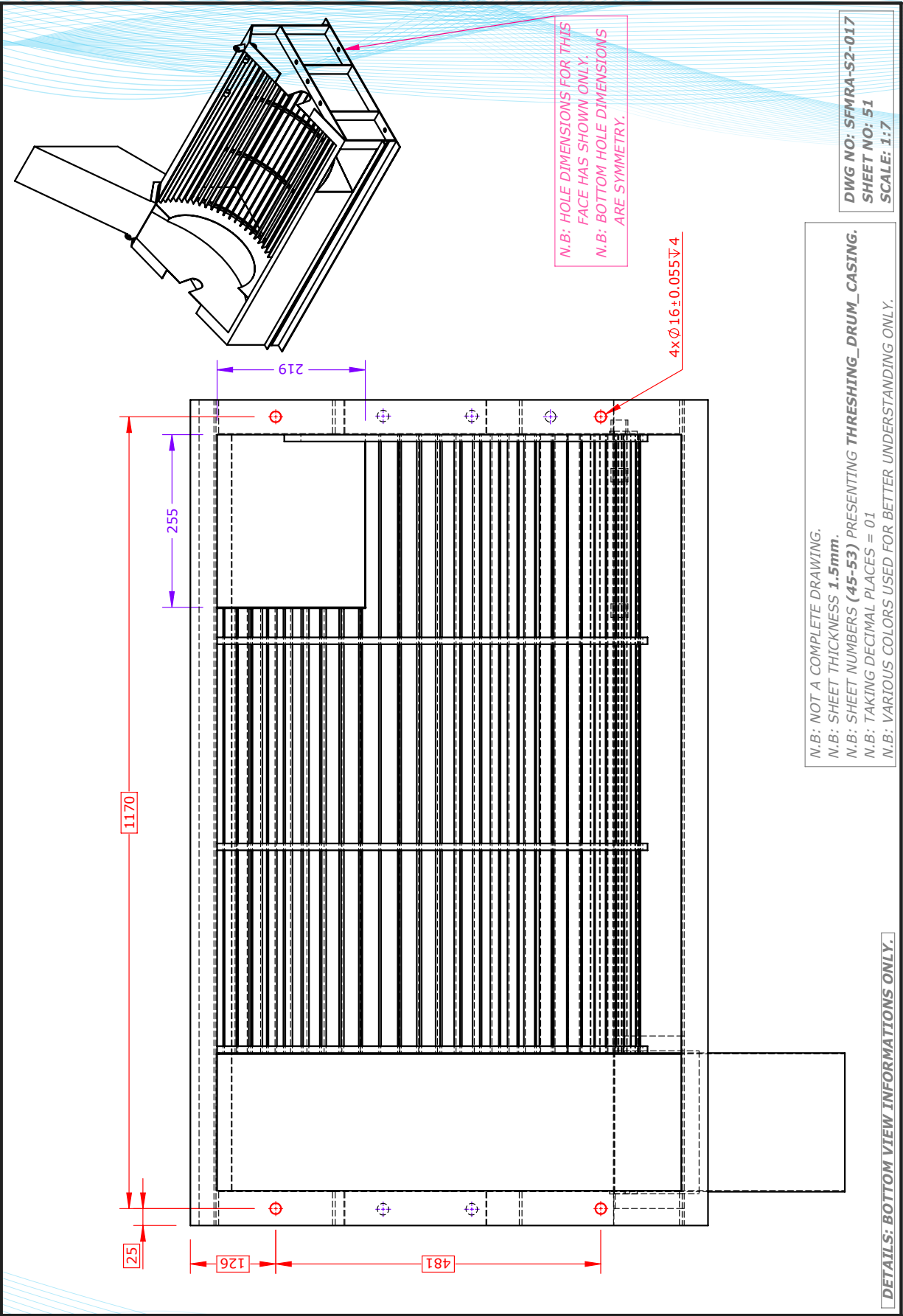

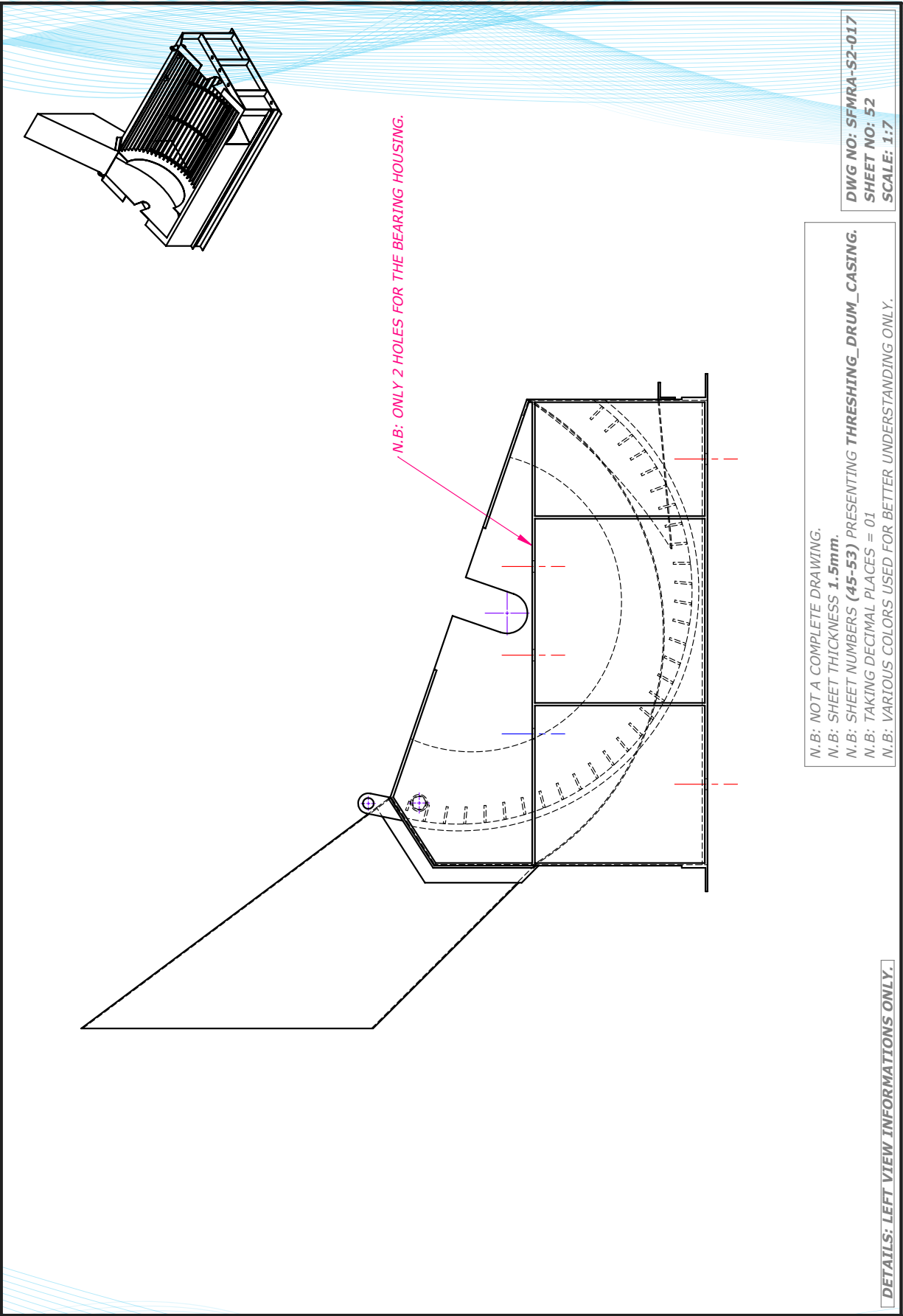

N.B: NOT A COMPLETE DRAWING.
 N.B: SHEET NUMBERS (45-53) PRESENTING **THRASHING_DRUM_CASING**.
 N.B: SECTION AND DETAIL VIEWS FROM **FRONT VIEW**.
 N.B: TAKING DECIMAL PLACES = 01
 N.B: VARIOUS COLORS USED FOR BETTER UNDERSTANDING ONLY.

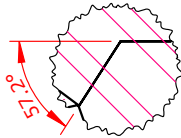

DETAIL E
 SCALE 1 : 10

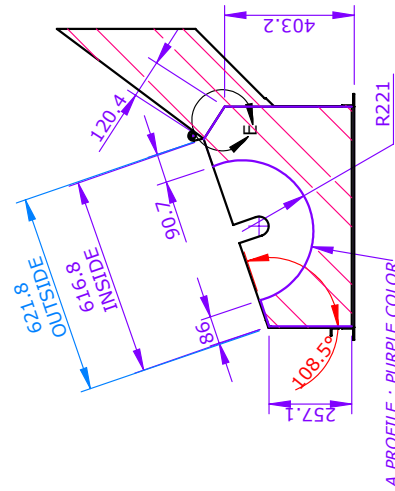

SECTION D-D

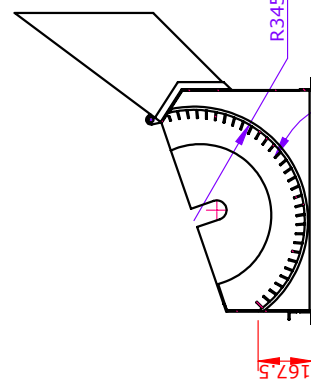

SECTION F-F

N.B: CHECK SHEET NUMBER 42 (4th ROW IN TABLE).
 TOTAL PATTERN = 32 (ONLY VALID FOR SECTION F-F)
 PATTERN INFO: EQUAL TANGENTIAL SPACING ON THE RADIUS (R345).
 DEGREES = 5

INFO:
 HIDDEN LINES: OFF
 [ONLY FOR THIS FRONT VIEW, SECTION VIEWS (C-C) & (D-D)]
 VISUALIZATION: GOOD

N.B: CHECK SECTION D-D

N.B: CHECK SHEET NUMBER 42 (4th ROW IN TABLE).
 TOTAL PATTERN = 23 (ONLY VALID FOR SECTION C-C)
 PATTERN INFO: EQUAL TANGENTIAL SPACING ON THE RADIUS (R345); DEGREES = 5

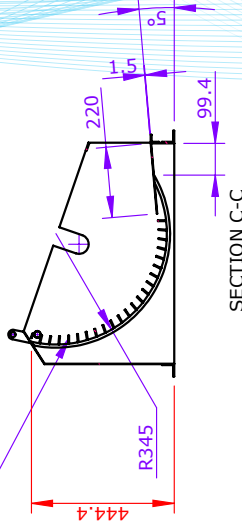

SECTION C-C

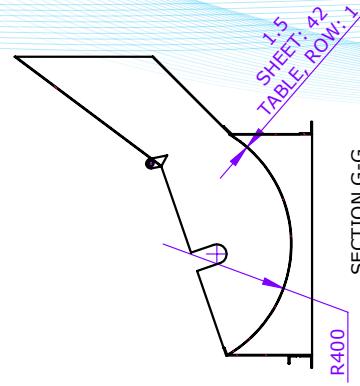



SECTION G-G

1.5
 SHEET: 42
 TABLE: ROW: 1

DWG NO: SFMRA-S2-017
 SHEET NO: 53
 SCALE: 1:20



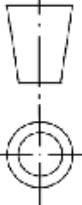

UCP-207
BORE DIAMETER: 35mm

UNLESS OTHERWISE SPECIFIED: STD. TOLERANCE DIMENSIONS ARE IN MILLIMETER MILLIMETER: ± 0.1, ANGULAR: ±0.05° * DOES NOT APPLY TO HOLE SIZE				BANGLADESH RICE RESEARCH INSTITUTE SFMRA PROJECT, FMPHT DIVISION		DO NOT SCALE DRAWING FINISH: _____ NONE FIRST ISSUED: 15-APR-2024	
DETAILS NAME DRAWN ENGR. SHAFIET JAHAN KHAN CHK'D DR. MD. MOSHARRAF HOSSAIN APP'VD DR. AKM SAIFUL ISLAM		SIGNATURE S J K M M H A S I		DATE 08-MAY-2024 18-MAY-2024 20-JULY-2024		TITLE: BRRRI RICE-WHEAT THRESHER (BRRRI TH2023) DRG. NAME: UCP-207 DWG NO: SFMRA-S2-018 OUTSOURCING: VENDOR MATERIAL: N/A SCALE: 1:2	
		THIRD ANGLE PROJECTION: 		WEIGHT: N/A SHEET: 54		REVISION: A	

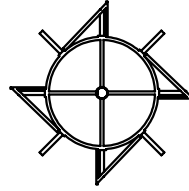
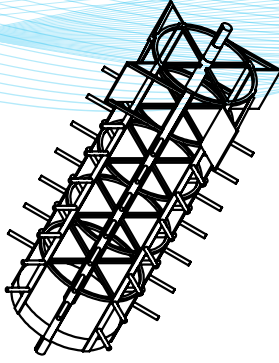
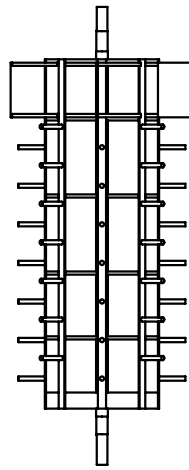
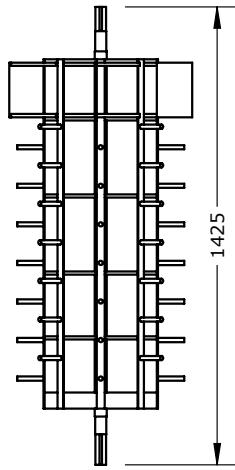
N.B: TAKING DECIMAL PLACES: 01

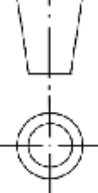

N.B: NOT A COMPLETE DRAWING.
 N.B: SHEET NUMBERS (55-60) PRESENTING THRESHER_ROTOR.
 N.B: VARIOUS COLORS USED FOR BETTER UNDERSTANDING ONLY.

UNLESS OTHERWISE SPECIFIED: STD. TOLERANCE DIMENSIONS ARE IN MILLIMETER MILLIMETER: ± 0.1, ANGULAR: ±0.05° * DOES NOT APPLY TO HOLE SIZE				BANGLADESH RICE RESEARCH INSTITUTE SFMRA PROJECT, FMPHT DIVISION		DO NOT SCALE DRAWING	
DETAILS		NAME	SIGNATURE	DATE	FINISH: NONE		
DRAWN	ENGR. SHAFTER JAHAN KHAN	ENGR. SHAFTER JAHAN KHAN	S J K	08-MAY-2024	FIRST ISSUED: 15-APR-2024		
CHK'D	DR. MD. MOHARRAF HOSSAIN	DR. MD. MOHARRAF HOSSAIN	M M H	18-MAY-2024	TITLE: BRRRI RICE-WHEAT THRESHER (BRRRI TH2023)		
APP'VD	DR. AKM SAIFUL ISLAM	DR. AKM SAIFUL ISLAM	A S I	20-JULY-2024	DRG. NAME: THRESHER_ROTOR		
THIRD ANGLE PROJECTION:				DWG NO: SFMRA-S2-019			
				MANUFACTURING METHOD: MACHINING, BENDING & WELDING			
				MATERIAL: PLAIN CARBON STEEL		WEIGHT: 69533.84 g	
				SCALE: 1:20		SHEET: 55	
						REVISION: A	

N.B: VIEW SHEET NUMBER 56.
 N.B: ALL THE DIMENSIONS FOR THE SHAFTS, FLAT BARS, SQUARE BARS, PLATES HAS SHOWN THERE.
 N.B: TAKING DECIMAL PLACES: 01

NO.	DETAILS	SIZE (mm)
1.	SHAFT	DIA: 37
2.	SHAFT	DIA: 13
3.	FLAT BAR	25X3
4.	METAL PLATE THICKNESS	5
5.	SQUARE BAR	10x10

3. NUMBER OF PATTERNS: 08 x 2. NUMBER OF PATTERNS: 07 IN EACH ROW
 SO, TOTAL NUMBER OF PATTERNS AVAILABLE (SHAFT DIA: 13mm) = 56

2. NUMBER OF PATTERNS: 07 IN EACH ROW

3. NUMBER OF PATTERNS: 08

4. NUMBER OF PATTERNS: 04

1

50mm THICK MS PLATE, DIA 350
 QUANTITY: 01

5. NUMBER OF PATTERNS: 05

5. NUMBER OF PATTERNS: 05

5

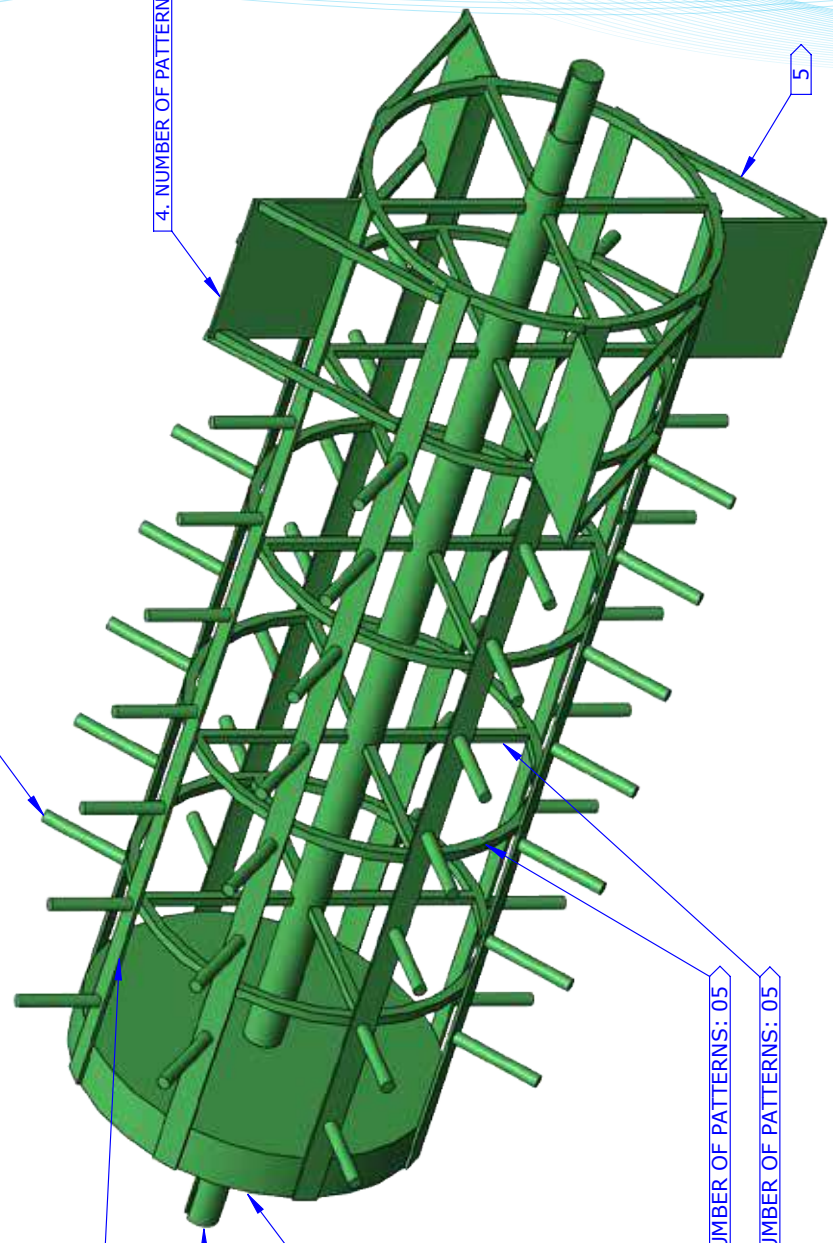

N.B: NOT A COMPLETE DRAWING.
 N.B: SHEET NUMBERS (55-60) PRESENTING THRESHER ROTOR.
 N.B: VARIOUS COLORS USED FOR BETTER UNDERSTANDING ONLY.
 N.B: ONLY ISOMETRIC VIEW INFORMATIONS ONLY.

DWG NO: SFMRA-S2-019
 SHEET NO: 56
 SCALE: 1:6

N.B.: VIEW SHEET NUMBER 56.
 N.B.: ALL THE DIMENSIONS FOR THE SHAFTS, FLAT
 BARS, SQUARE BARS, PLATES HAS SHOWN THERE.

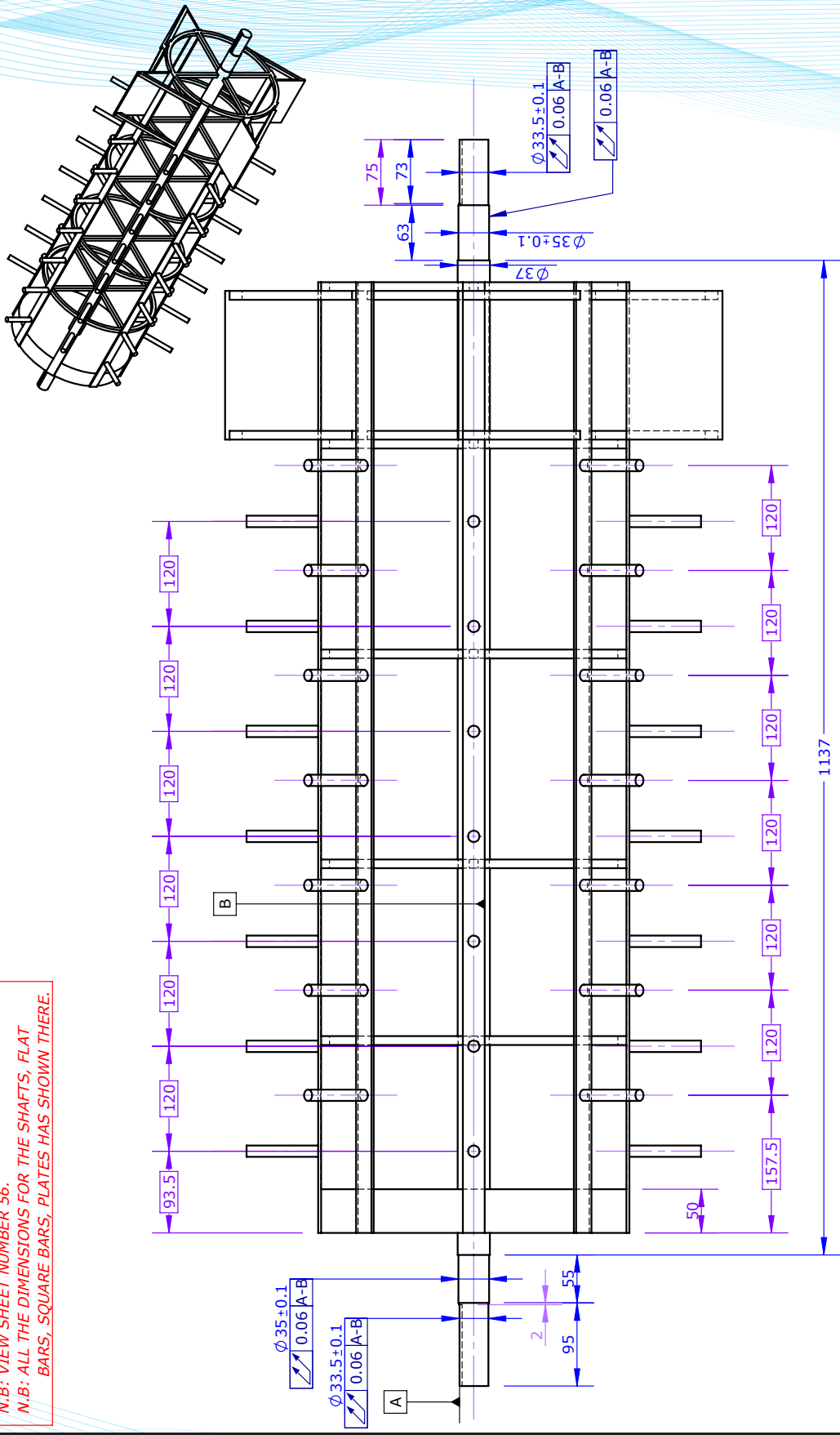

N.B.: NOT A COMPLETE DRAWING.
 N.B.: SHEET NUMBERS (55-60) PRESENTING THRESHER_ROTOR.
 N.B.: TAKING DECIMAL PLACES = 01
 N.B.: VARIOUS COLORS USED FOR BETTER UNDERSTANDING ONLY.

DWG NO: SFMRA-S2-019
 SHEET NO: 57
 SCALE: 1:6

DETAILS: FRONT VIEW INFORMATIONS ONLY.

N.B: VIEW SHEET NUMBER 56.
N.B: ALL THE DIMENSIONS FOR THE SHAFTS, FLAT
BARS, SQUARE BARS, PLATES HAS SHOWN THERE.

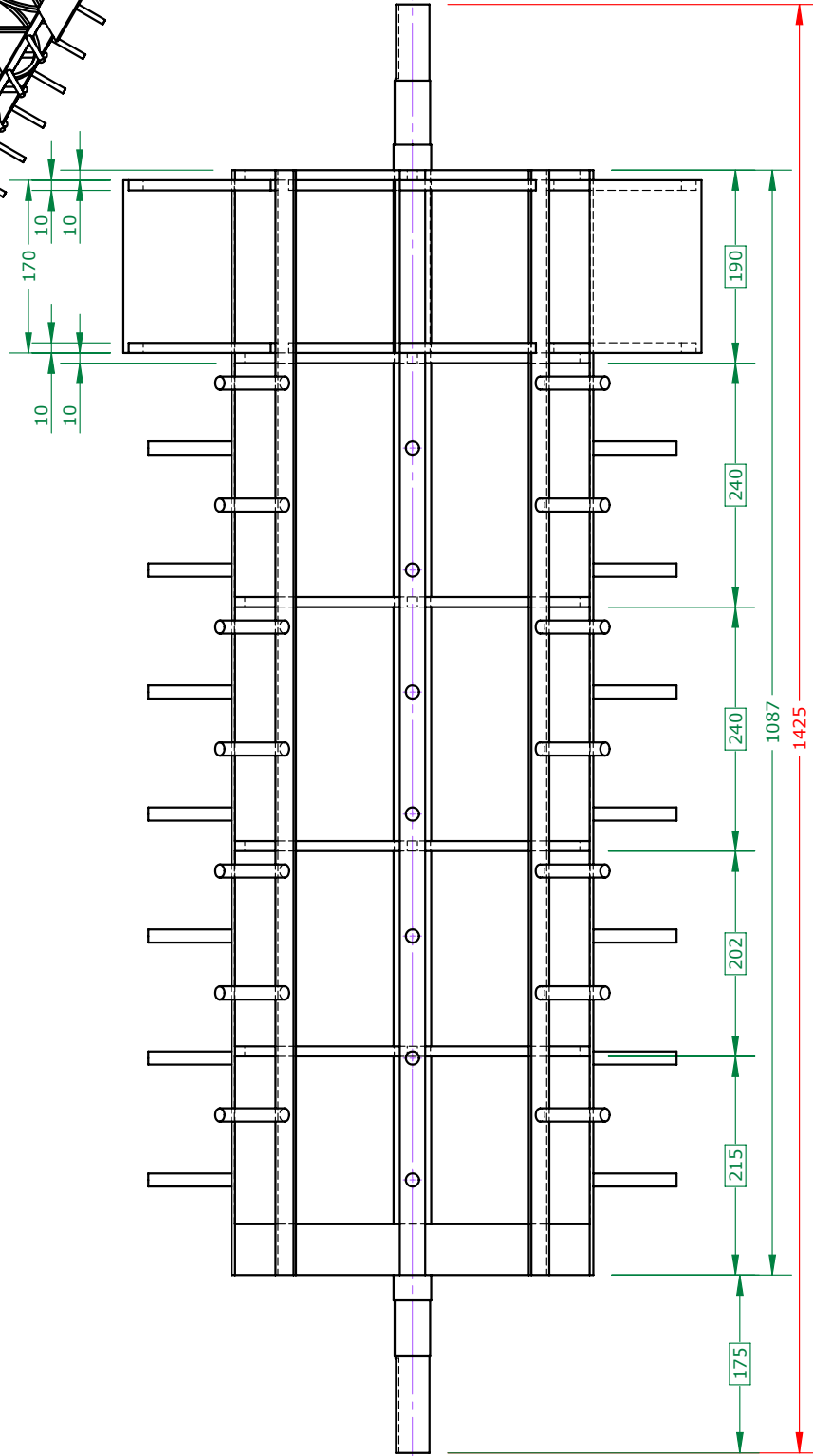
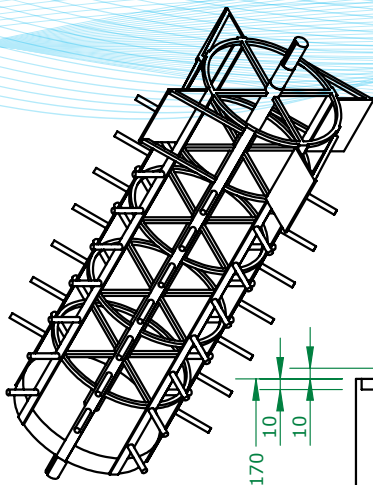

N.B: NOT A COMPLETE DRAWING.
N.B: SHEET NUMBERS (55-60) PRESENTING THRESHER_ROTOR.
N.B: TAKING DECIMAL PLACES = 01
N.B: VARIOUS COLORS USED FOR BETTER UNDERSTANDING ONLY.

DWG NO: SFMRA-S2-019
SHEET NO: 58
SCALE: 1:6

DETAILS: FRONT VIEW INFORMATIONS ONLY.

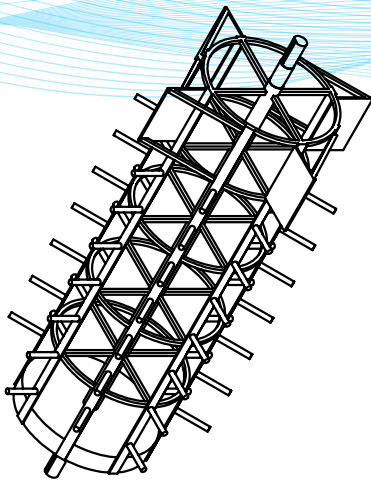

N.B: VIEW SHEET NUMBER 56.
 N.B: ALL THE DIMENSIONS FOR THE SHAFTS, FLAT BARS, SQUARE BARS, PLATES HAS SHOWN THERE.

*KEY SLOT FOR THE SHAFT.
 N.B: SAME SIZE FOR BOTH SIDE.

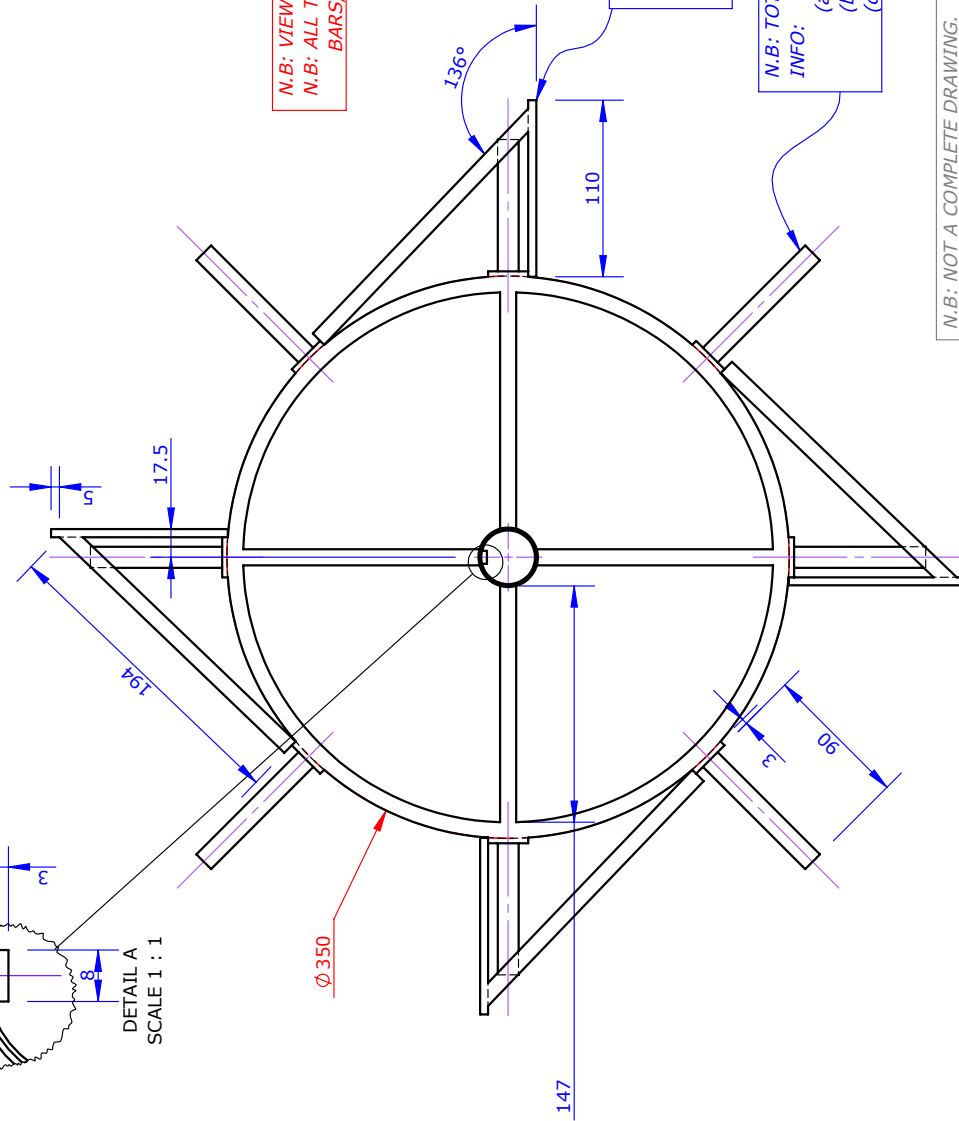
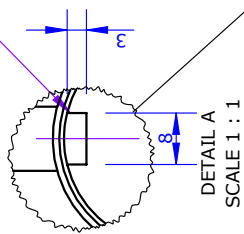

N.B: TOTAL CIRCULAR PATTERNS FOR THE PLATE: 04
 INFO:
 (a) PLACING: OUTSIDE THE CIRCLE ϕ 350
 (b) TOTAL ANGLE: 360°
 (c) MAINTAINING ANGLE: EQUAL DISTANCE (90°)

N.B: TOTAL CIRCULAR PATTERNS FOR THE SHAFT (ϕ 13): 08
 INFO:
 (a) PLACING: OUTSIDE THE CIRCLE ϕ 350
 (b) TOTAL ANGLE: 360°
 (c) MAINTAINING ANGLE: EQUAL DISTANCE (45°)

N.B: NOT A COMPLETE DRAWING.
 N.B: SHEET NUMBERS (55-60) PRESENTING THRESHER_ROTOR.
 N.B: TAKING DECIMAL PLACES = 01
 N.B: VARIOUS COLORS USED FOR BETTER UNDERSTANDING ONLY.

DWG NO: SFMRA-S2-019
 SHEET NO: 59
 SCALE: 1:4

DETAILS: RIGHT VIEW INFORMATIONS ONLY.

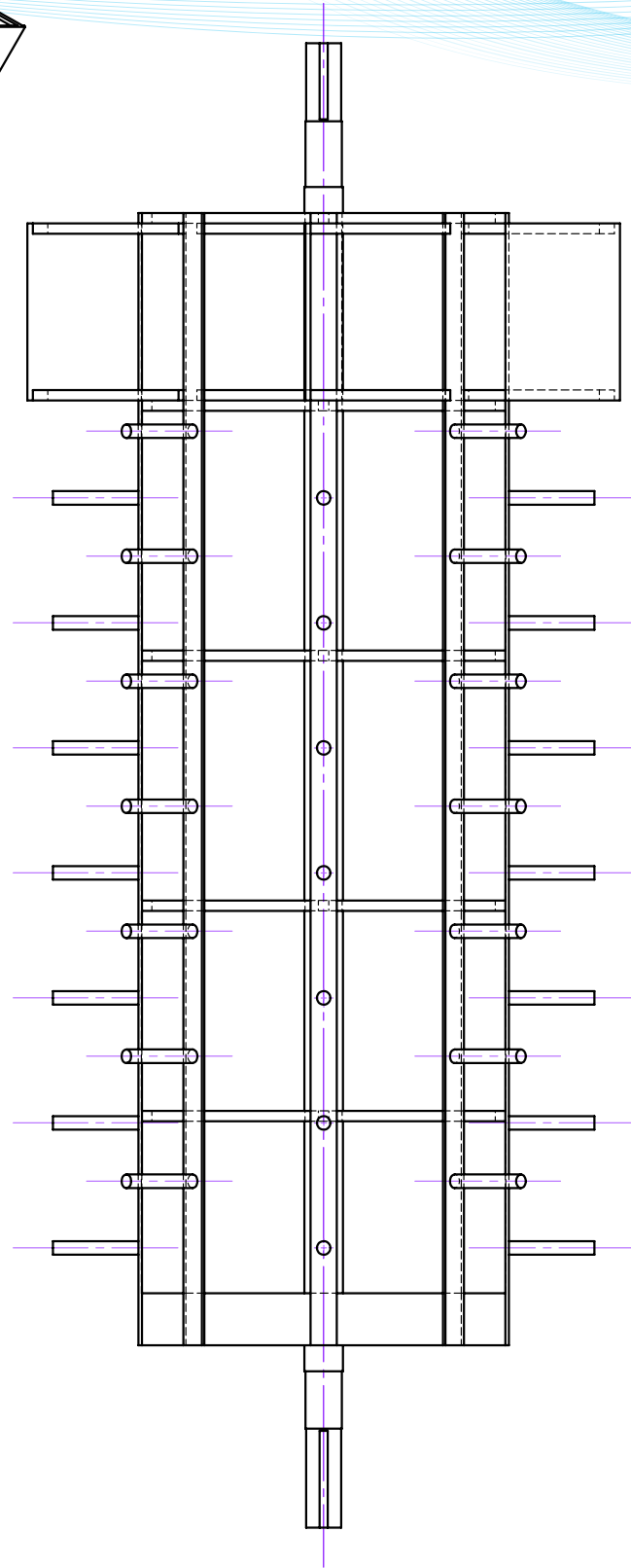
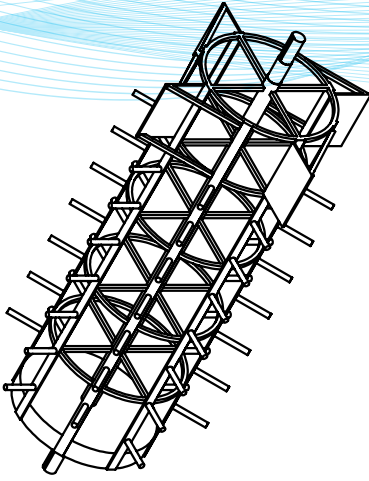

N.B: NOT A COMPLETE DRAWING.
N.B: SHEET NUMBERS (55-60) PRESENTING **THRESHER_ROTOR**.
N.B: TAKING DECIMAL PLACES = 01
N.B: VARIOUS COLORS USED FOR BETTER UNDERSTANDING ONLY.

DWG NO: SFMRA-S2-019
SHEET NO: 60
SCALE: 1:6

DETAILS: TOP VIEW INFORMATIONS ONLY.

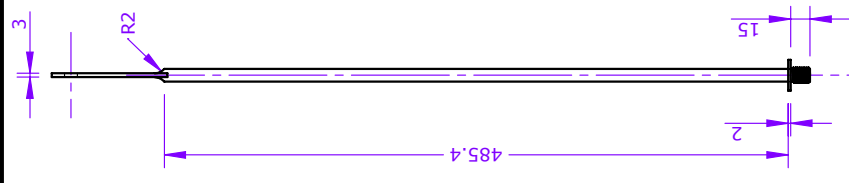
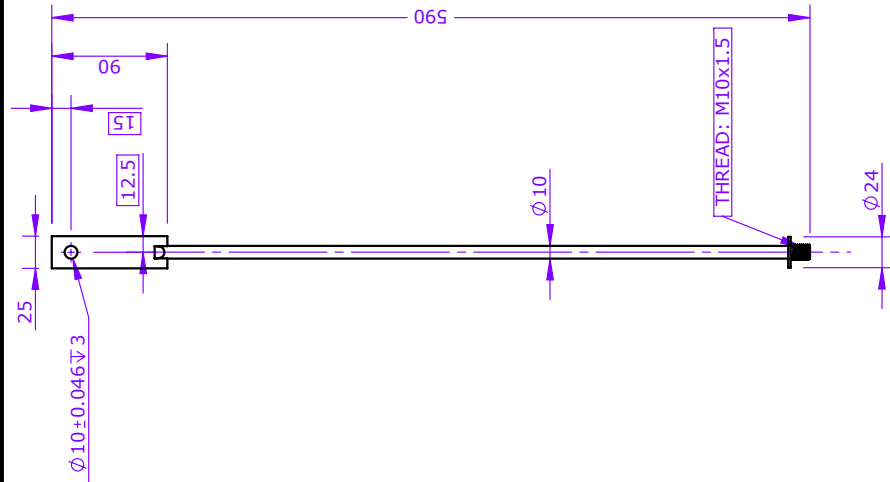

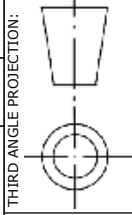
UNLESS OTHERWISE SPECIFIED: STD. TOLERANCE DIMENSIONS ARE IN MILLIMETER MILLIMETER: ± 0.1, ANGULAR: ±0.05° * DOES NOT APPLY TO HOLE SIZE		 BANGLADESH RICE RESEARCH INSTITUTE SFMRA PROJECT, FMPHT DIVISION		DO NOT SCALE DRAWING	
DETAILS NAME SIGNATURE DATE DRAWN ENGR. SHAFIET JAHAN KHAN S J K 08-MAY-2024 CHK'D DR. MD. MOHARRAF HOSSAIN M M H 18-MAY-2024 APP'VD DR. AKM SAIFUL ISLAM A S I 20-JULY-2024		TITLE: BRRI RICE-WHEAT THRESHER (BRRI TH2023) DRG. NAME: FEEDING TRAY SUPPORT DWG NO: SFMRA-S2-022		FINISH: NONE FIRST ISSUED: 15-APR-2024	
 THIRD ANGLE PROJECTION:		MANUFACTURING METHOD: MACHINING & WELDING MATERIAL: ASTM A36 STEEL SCALE: 1:5		WEIGHT: 368.50 g SHEET: 63 REVISION: A	

N.B: TAKING DECIMAL PLACES: 01

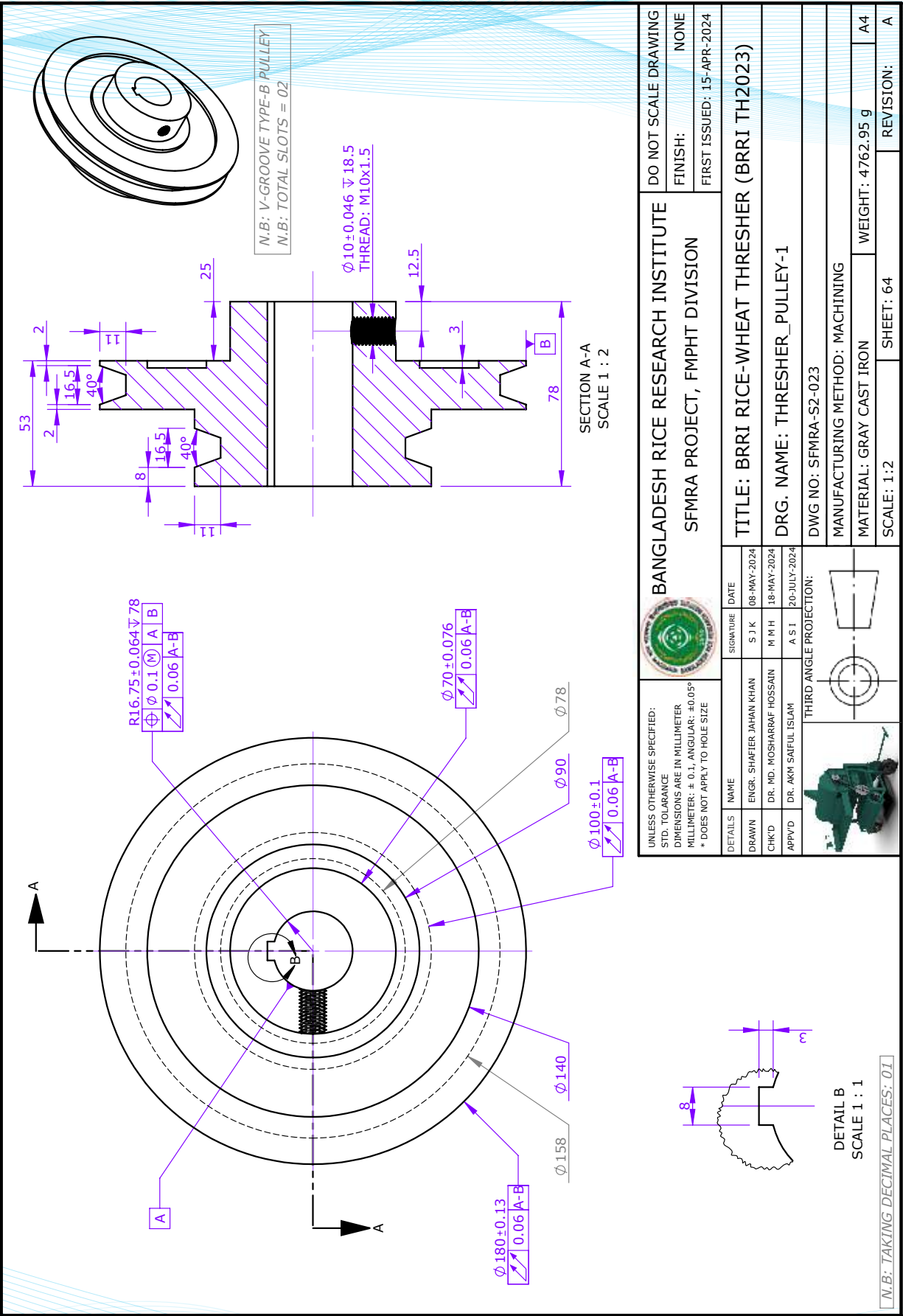

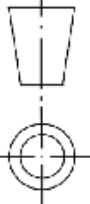
UNLESS OTHERWISE SPECIFIED: STD. TOLERANCE DIMENSIONS ARE IN MILLIMETER MILLIMETER: ± 0.1, ANGULAR: ±0.05° * DOES NOT APPLY TO HOLE SIZE				DO NOT SCALE DRAWING FINISH: NONE FIRST ISSUED: 15-APR-2024	
BANGLADESH RICE RESEARCH INSTITUTE SFMRA PROJECT, FMPHT DIVISION		TITLE: BRRRI RICE-WHEAT THRESHER (BRRITH2023)			
DR. MD. MOHSINUR RAHMAN DR. AKM SAIFUL ISLAM		DRG. NAME: THRESHER_PULLEY-1 DWG NO: SFMRA-S2-023			
ENGR. SHAFER JAHAN KHAN DR. MD. MOHSINUR RAHMAN DR. AKM SAIFUL ISLAM		SIGNATURE S J K M M H A S I			
DATE 08-MAY-2024 18-MAY-2024 20-JULY-2024		THIRD ANGLE PROJECTION: 			
MANUFACTURING METHOD: MACHINING MATERIAL: GRAY CAST IRON SCALE: 1:2		WEIGHT: 4762.95 g SHEET: 64		REVISION: A	

N.B: TAKING DECIMAL PLACES: 01

DETAIL B
SCALE 1 : 1

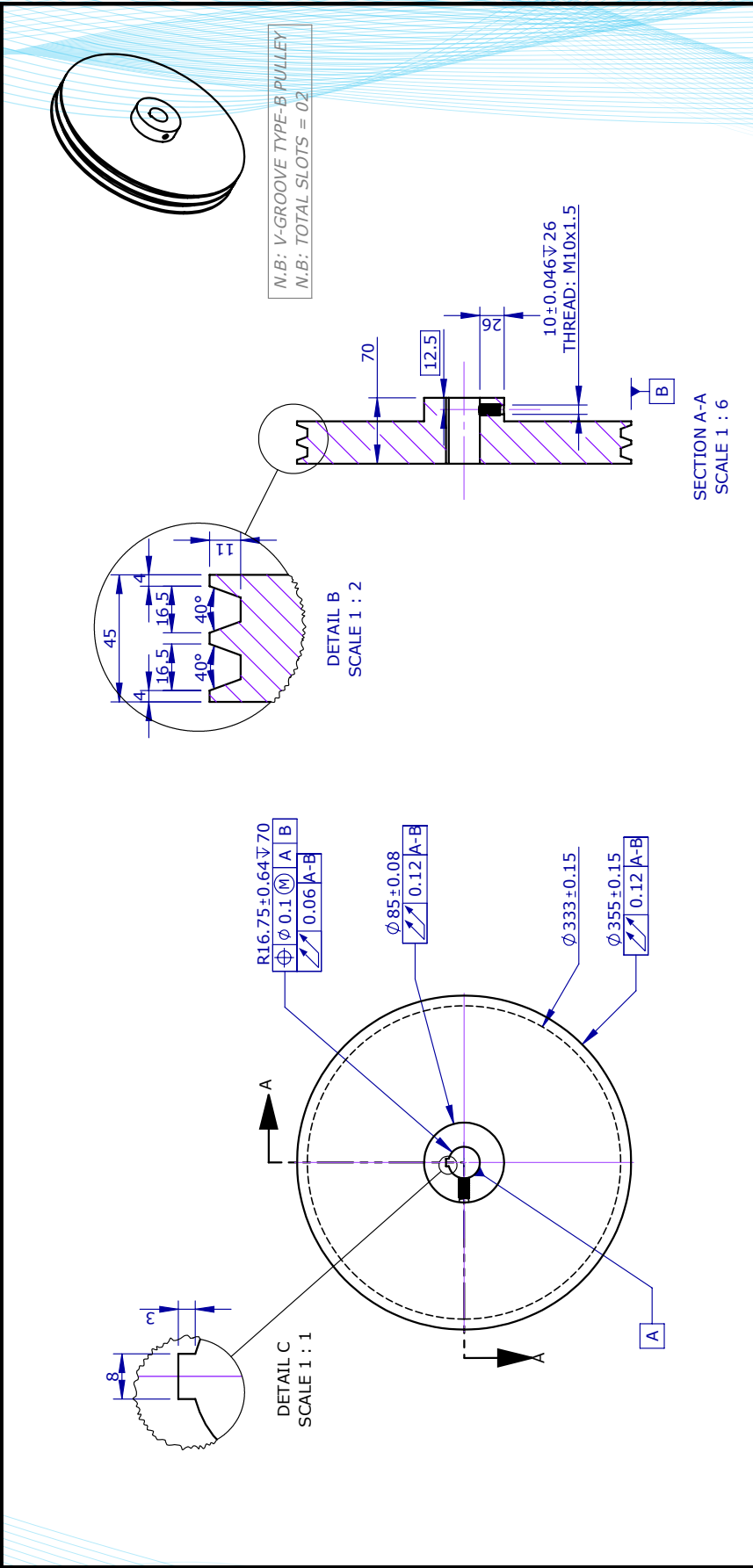



N.B: V-GROOVE TYPE-B PULLEY
N.B: TOTAL SLOTS = 02

SECTION A-A
SCALE 1 : 6

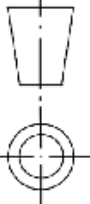

DETAIL B
SCALE 1 : 2

DETAIL C
SCALE 1 : 1

UNLESS OTHERWISE SPECIFIED: STD. TOLERANCE DIMENSIONS ARE IN MILLIMETER MILLIMETER: ± 0.1, ANGULAR: ±0.05° * DOES NOT APPLY TO HOLE SIZE				DO NOT SCALE DRAWING
BANGLADESH RICE RESEARCH INSTITUTE SFMRA PROJECT, FMPHT DIVISION		TITLE: BIRRI RICE-WHEAT THRESHER (BIRRI TH2023) DRG. NAME: THRESHER_PULLEY-2		FINISH: NONE
DETAILS DRAWN ENGR. SHAFTER JAHAN KHAN CHK'D DR. MD. MOSHARRAF HOSSAIN APP'VD DR. AKM SAIFUL ISLAM		DWG NO: SFMRA-S2-024 MANUFACTURING METHOD: MACHINING MATERIAL: GRAY CAST IRON SCALE: 1:6		FIRST ISSUED: 15-APR-2024
NAME ENGR. SHAFTER JAHAN KHAN DR. MD. MOSHARRAF HOSSAIN DR. AKM SAIFUL ISLAM		SIGNATURE S J K M M H A S I		
DATE 08-MAY-2024 18-MAY-2024 20-JULY-2024		THIRD ANGLE PROJECTION: 		
		WEIGHT: 30472.86 g SHEET: 65 REVISION: A		

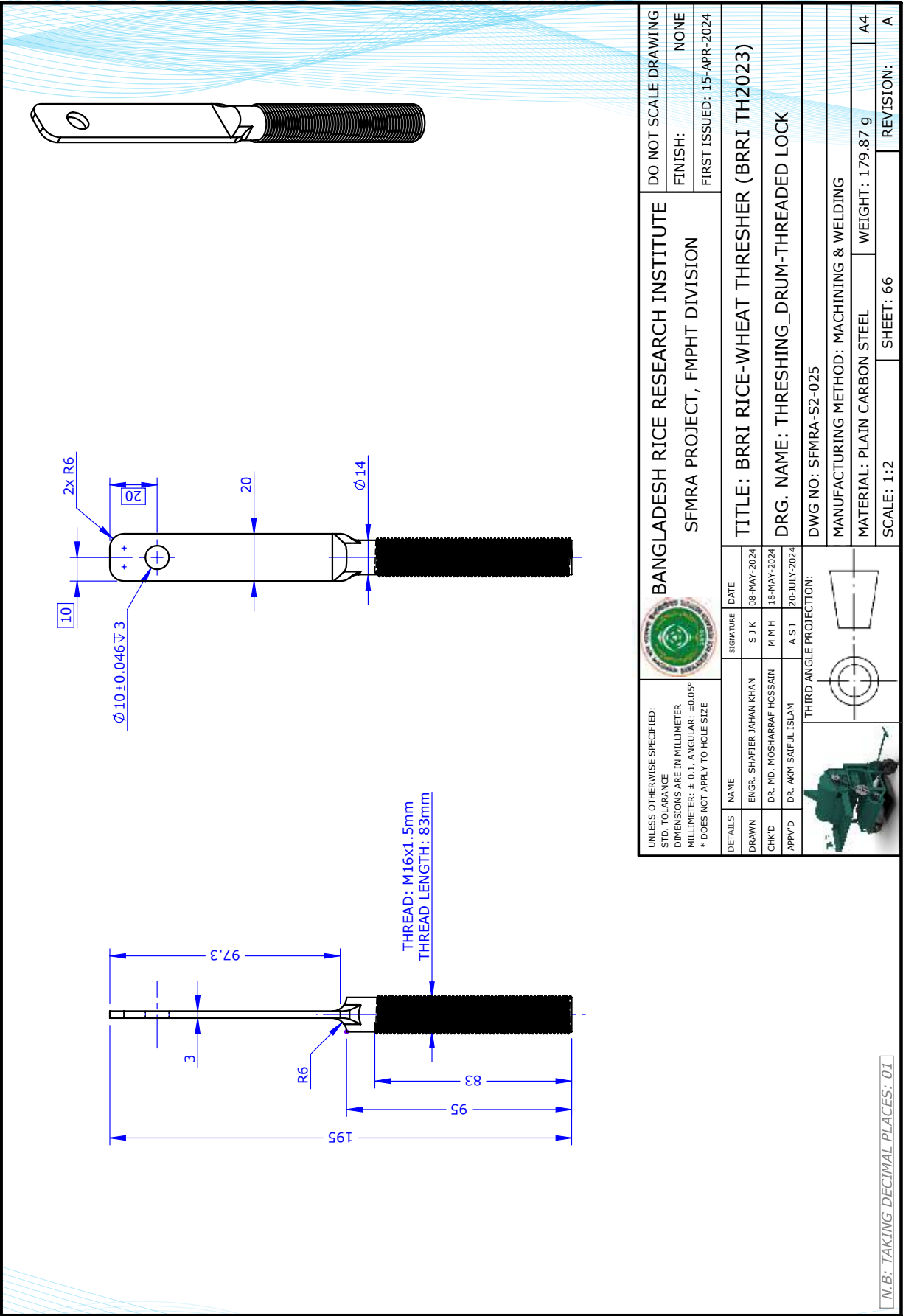

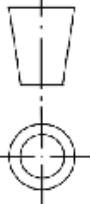
N.B: TAKING DECIMAL PLACES: 01

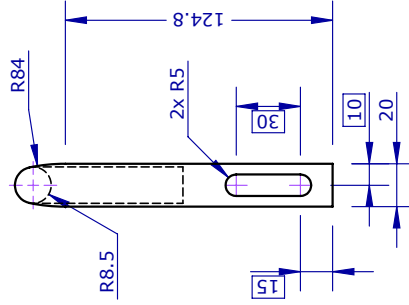
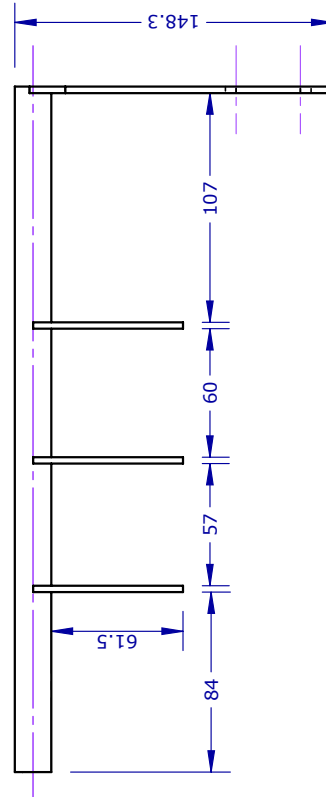
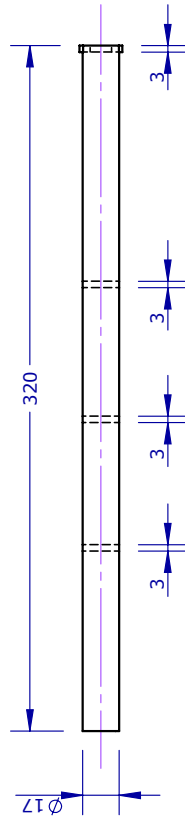
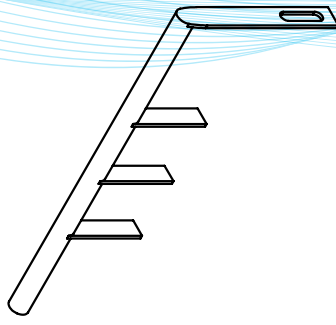

UNLESS OTHERWISE SPECIFIED: STD. TOLERANCE DIMENSIONS ARE IN MILLIMETER MILLIMETER: ± 0.1, ANGULAR: ±0.05° * DOES NOT APPLY TO HOLE SIZE				BANGLADESH RICE RESEARCH INSTITUTE SFMRA PROJECT, FMPHT DIVISION		DO NOT SCALE DRAWING	
DETAILS		NAME	SIGNATURE	DATE	FINISH: NONE		
DRAWN	ENGR. SHAFIET JAHAN KHAN	S J K		08-MAY-2024	FIRST ISSUED: 15-APR-2024		
CHK'D	DR. MD. MOSHARRAF HOSSAIN	M M H		18-MAY-2024	TITLE: BRRRI RICE-WHEAT THRESHER (BRRRI TH2023)		
APP'VD	DR. AKM SAIFUL ISLAM	A S I		20-JULY-2024	DRG. NAME: THRESHING_DRUM-THREADED LOCK		
THIRD ANGLE PROJECTION:				DWG NO: SFMRA-S2-025			
		MANUFACTURING METHOD: MACHINING & WELDING		MATERIAL: PLAIN CARBON STEEL			
		SCALE: 1:2		SHEET: 66		REVISION: A	
		WEIGHT: 179.87 g		A4			

N.B: TAKING DECIMAL PLACES: 01

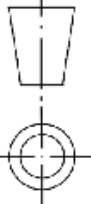



UNLESS OTHERWISE SPECIFIED: STD. TOLERANCE DIMENSIONS ARE IN MILLIMETER MILLIMETER: ± 0.1, ANGULAR: ±0.05° * DOES NOT APPLY TO HOLE SIZE		 BANGLADESH RICE RESEARCH INSTITUTE SFMRA PROJECT, FMPHT DIVISION		DO NOT SCALE DRAWING	
DETAILS		SIGNATURE	DATE	FINISH:	NONE
DRAWN	ENGR. SHAFTER JAHAN KHAN	S J K	08-MAY-2024	FIRST ISSUED:	15-APR-2024
CHK'D	DR. MD. MOSHARRAF HOSSAIN	M M H	18-MAY-2024	TITLE: BRRRI RICE-WHEAT THRESHER (BRRRI TH2023)	
APP'VD	DR. AKM SAIFUL ISLAM	A S I	20-JULY-2024	DRG. NAME: THRESHING_DRUM-STRAW_CUTTING_BLADE	
THIRD ANGLE PROJECTION:				DWG NO: SFMRA-S2-026	
		MANUFACTURING METHOD: MACHINING & WELDING		MATERIAL: ASTM A36 STEEL	
		SCALE: 1:3		WEIGHT: 700.19 g	
		SHEET: 67		REVISION: A	

N.B: TAKING DECIMAL PLACES: 01

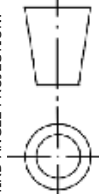

INFO: NUT: M16
 PITCH: 1.5
 QUANTITY: 03
 PLACING: THRESHING DRUM-THREADED LOCK [DWG NO: SFMRA-S2-025]

UNLESS OTHERWISE SPECIFIED: STD. TOLERANCE DIMENSIONS ARE IN MILLIMETER MILLIMETER: ± 0.1, ANGULAR: ±0.05° * DOES NOT APPLY TO HOLE SIZE		 BANGLADESH RICE RESEARCH INSTITUTE SFMRA PROJECT, FMPHT DIVISION		DO NOT SCALE DRAWING
DETAILS DRAWN ENGR. SHAFIET JAHAN KHAN CHK'D DR. MD. MOSHARRAF HOSSAIN APP'VD DR. AKM SAIFUL ISLAM		SIGNATURE S J K M M H A S I	DATE 08-MAY-2024 18-MAY-2024 20-JULY-2024	FINISH: NONE FIRST ISSUED: 15-APR-2024
		TITLE: BRRRI RICE-WHEAT THRESHER (BRRRI TH2023) DRG. NAME: NUT_M16 DWG NO: SFMRA-S2-027 OUTSOURCING: VENDOR MATERIAL: STAINLESS STEEL (FERRITIC) SCALE: 2:1		
THIRD ANGLE PROJECTION: 		WEIGHT: 24.04 g SHEET: 68 REVISION: A		

N.B: TAKING DECIMAL PLACES: 01

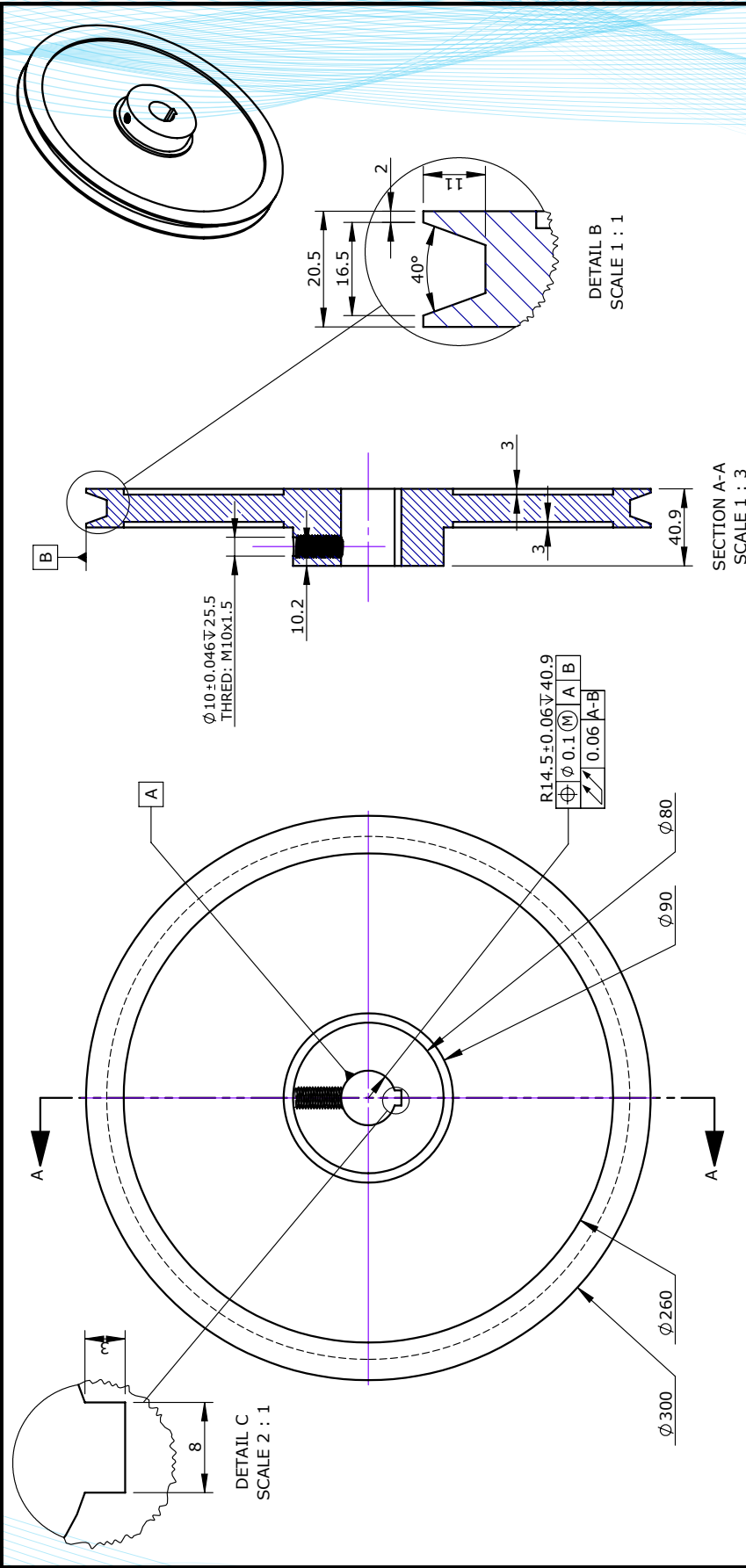

SECTION A-A
SCALE 1 : 3

DETAIL B
SCALE 1 : 1

DETAIL C
SCALE 2 : 1

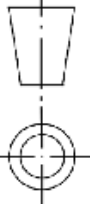
UNLESS OTHERWISE SPECIFIED: STD. TOLERANCE DIMENSIONS ARE IN MILLIMETER MILLIMETER: ± 0.1, ANGULAR: ±0.05° * DOES NOT APPLY TO HOLE SIZE				DO NOT SCALE DRAWING
BANGLADESH RICE RESEARCH INSTITUTE SFMRA PROJECT, FMPHT DIVISION		TITLE: BRRRI RICE-WHEAT THRESHER (BRRRI TH2023) DRG. NAME: CLEANER_V-PULLEY_TYPE-B		FINISH: NONE
DETAILS DRAWN ENGR. SHAFTER JAHAN KHAN CHK'D DR. MD. MOSHARRAF HOSSAIN APP'VD DR. AKM SAIFUL ISLAM		SIGNATURE S J K M M H A S I	DATE 15-MAY-2024 18-MAY-2024 20-JULY-2024	FIRST ISSUED: 15-APR-2024
THIRD ANGLE PROJECTION: 		DWG NO: SFMRA-S3-028 MANUFACTURING METHOD: MACHINING MATERIAL: GRAY CAST IRON SCALE: 1:3		WEIGHT: 8031.92 g REVISION: A

N.B: TAKING DECIMAL PLACES: 01

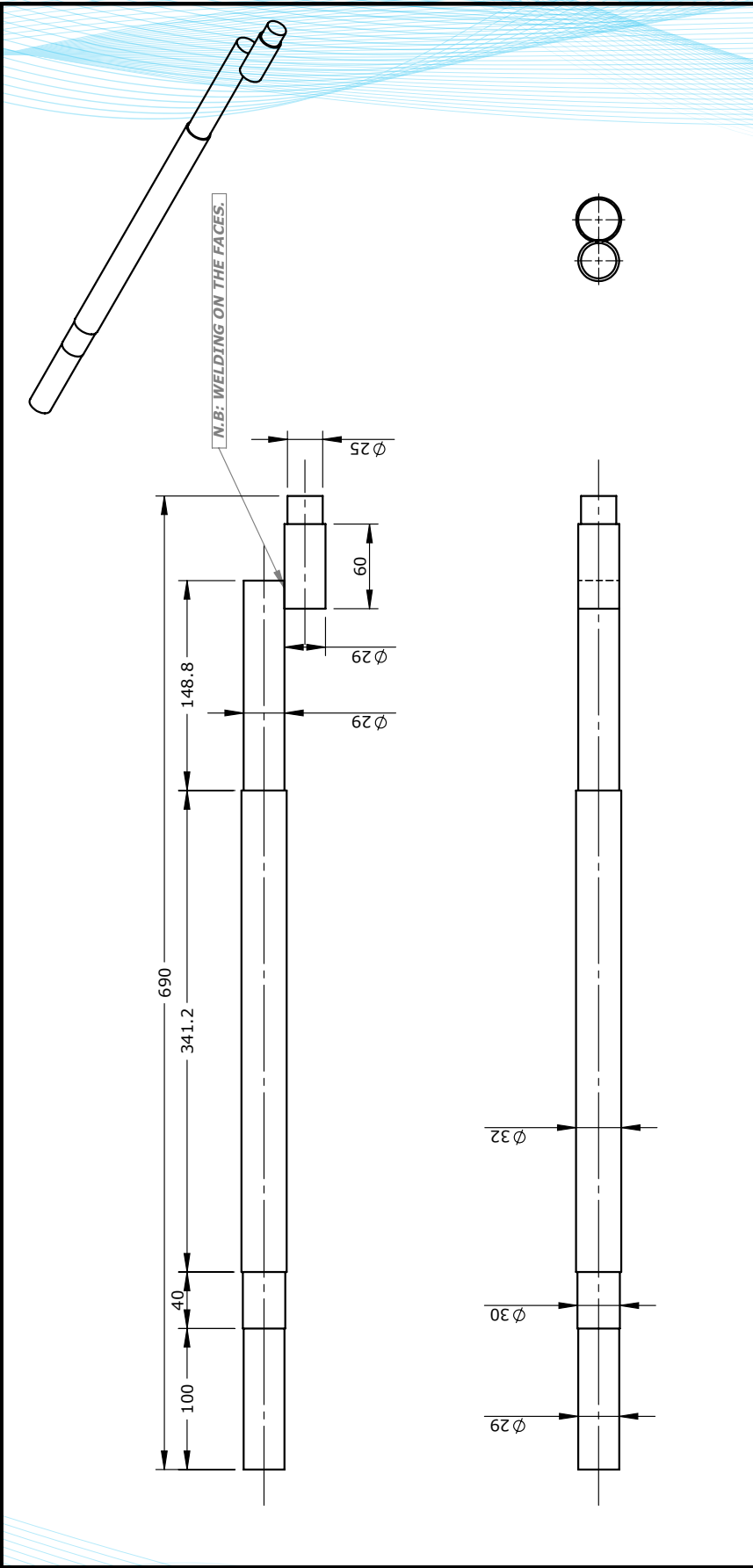

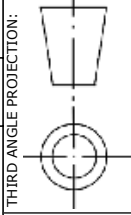

UNLESS OTHERWISE SPECIFIED: STD. TOLERANCE DIMENSIONS ARE IN MILLIMETER MILLIMETER: ± 0.1, ANGULAR: ±0.05° * DOES NOT APPLY TO HOLE SIZE		 BANGLADESH RICE RESEARCH INSTITUTE SFMRA PROJECT, FMPHT DIVISION		DO NOT SCALE DRAWING
DETAILS		SIGNATURE	DATE	FINISH: NONE
DRAWN	ENGR. SHAFFER JAHAN KHAN	S J K	15-MAY-2024	FIRST ISSUED: 15-APR-2024
CHK'D	DR. MD. MOSHARRAF HOSSAIN	M M H	18-MAY-2024	
APP'VD	DR. AKM SAIFUL ISLAM	A S I	20-JULY-2024	
THIRD ANGLE PROJECTION:				
TITLE: BRRI RICE-WHEAT THRESHER (BRRI TH2023) DRG. NAME: CLEANER_CAM-SHAFT DWG NO: SFMRA-S3-030 MANUFACTURING METHOD: MACHINING MATERIAL: PLAIN CARBON STEEL SCALE: 1:5 WEIGHT: 4028.46 g SHEET: 71 REVISION: A				

N.B: TAKING DECIMAL PLACES: 01



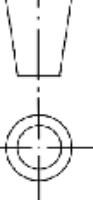

BEARING TYPE: **BALL BEARING**
 MODEL: **6205 RS**
 INNER DIAMETER: 25mm
 OUTER DIAMETER: 52mm

UNLESS OTHERWISE SPECIFIED: STD. TOLERANCE DIMENSIONS ARE IN MILLIMETER MILLIMETER: ± 0.1, ANGULAR: ±0.05° * DOES NOT APPLY TO HOLE SIZE			BANGLADESH RICE RESEARCH INSTITUTE		DO NOT SCALE DRAWING
			SFMRA PROJECT, FMPHT DIVISION		
			TITLE: BRRRI RICE-WHEAT THRESHER (BRRRI TH2023)		
DETAILS	NAME	SIGNATURE	DATE		
DRAWN	ENGR. SHAFTER JAHAN KHAN	S J K	15-MAY-2024		
CHK'D	DR. MD. MOSHARRAF HOSSAIN	M M H	18-MAY-2024		
APP'VD	DR. AKM SAIFUL ISLAM	A S I	20-JULY-2024		
THIRD ANGLE PROJECTION:					
					
DRG. NAME: 6205_RS_BEARING			DWG NO: SFMRA-S3-031		
OUTSOURCING: VENDOR			MATERIAL: N/A		
SCALE: 1:1			SHEET: 72		
WEIGHT: N/A			REVISION: A		

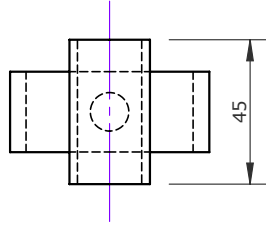
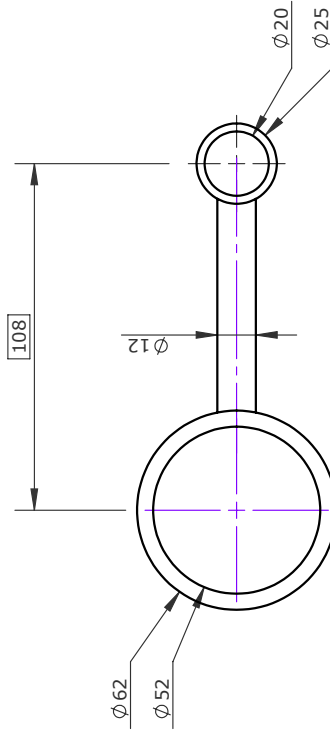
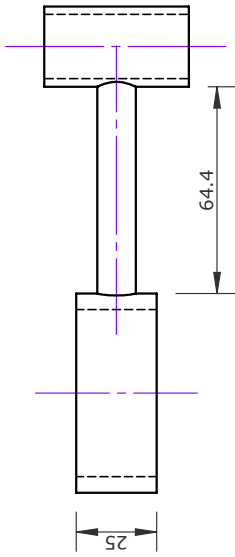
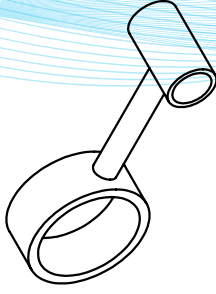
N.B: TAKING DECIMAL PLACES: 01

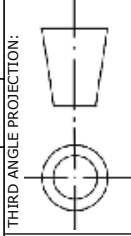





UNLESS OTHERWISE SPECIFIED: STD. TOLERANCE DIMENSIONS ARE IN MILLIMETER MILLIMETER: ± 0.1, ANGULAR: ±0.05° * DOES NOT APPLY TO HOLE SIZE				BANGLADESH RICE RESEARCH INSTITUTE SFMRA PROJECT, FMPHT DIVISION		DO NOT SCALE DRAWING FINISH: NONE FIRST ISSUED: 15-APR-2024	
DETAILS	NAME	SIGNATURE	DATE	TITLE: BRRI RICE-WHEAT THRESHER (BRRI TH2023)			
DRAWN	ENGR. SHAFTER JAHAN KHAN	S J K	15-MAY-2024	DRG. NAME: BEARING HOLDER			
CHK'D	DR. MD. MOSHARRAF HOSSAIN	M M H	18-MAY-2024	DWG NO: SFMRA-S3-032			
APP'VD	DR. AKM SAIFUL ISLAM	A S I	20-JULY-2024	MANUFACTURING METHOD: MACHINING, WELDING			
			THIRD ANGLE PROJECTION:				
			MATERIAL: PLAIN CARBON STEEL				
			SCALE: 1:2		WEIGHT: 293.80 g		A4
			SHEET: 73		REVISION:		A

N.B: TAKING DECIMAL PLACES: 01

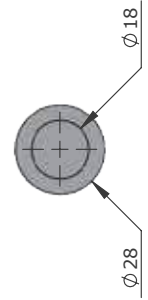
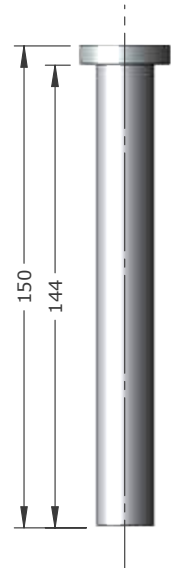

N.B: PURCHASE DIRECTLY FROM THE MARKET.

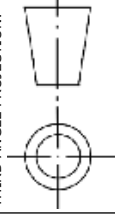

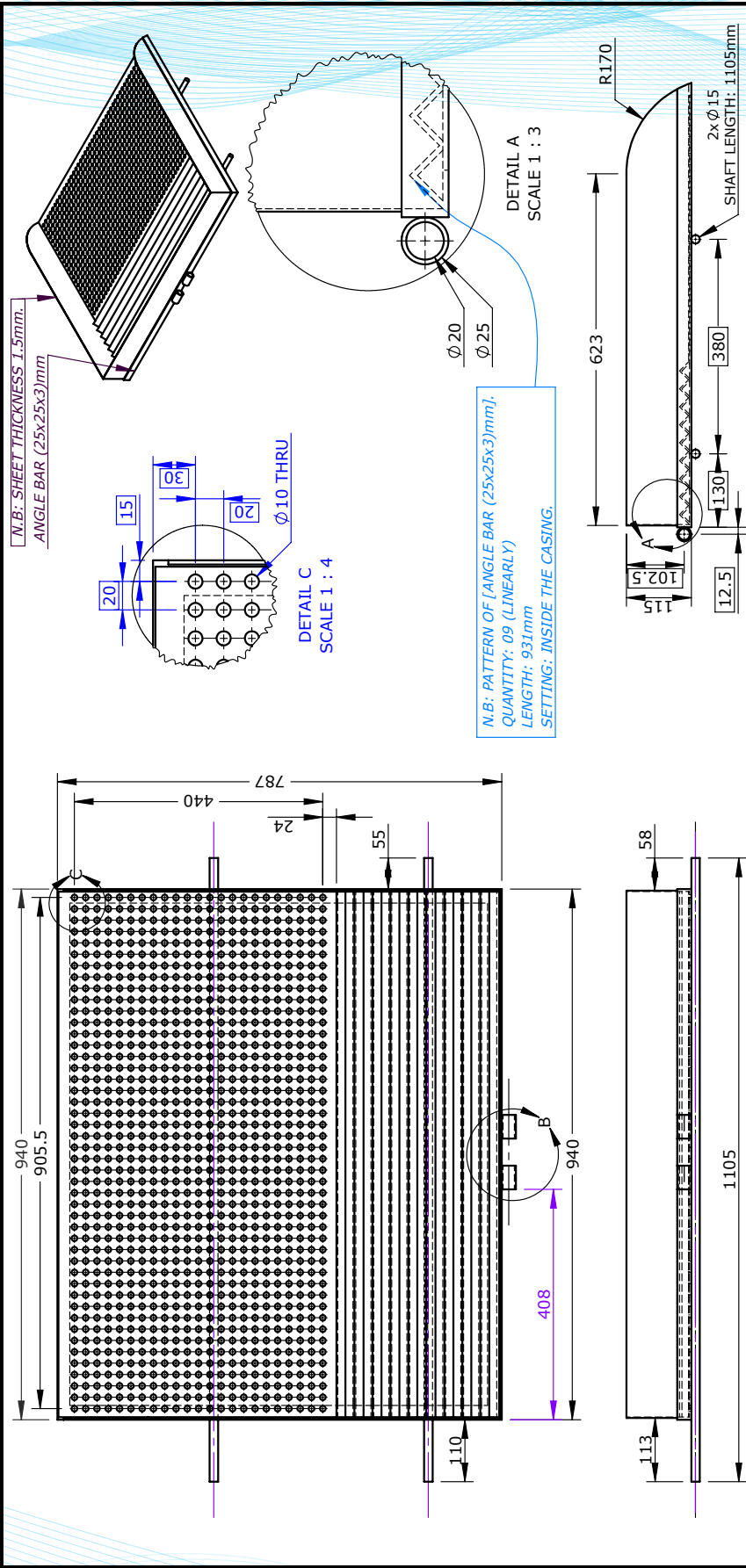

UNLESS OTHERWISE SPECIFIED: STD. TOLERANCE DIMENSIONS ARE IN MILLIMETER MILLIMETER: ± 0.1, ANGULAR: ±0.05° * DOES NOT APPLY TO HOLE SIZE			BANGLADESH RICE RESEARCH INSTITUTE SFMRA PROJECT, FMPHT DIVISION		DO NOT SCALE DRAWING
			TITLE: BIRRI RICE-WHEAT THRESHER (BIRRI TH2023) DRG. NAME: LOCKING_PIN		FINISH: NONE FIRST ISSUED: 15-APR-2024
DETAILS	NAME	SIGNATURE	DATE		
DRAWN	ENGR. SHAFIER JAHAN KHAN	S J K	15-MAY-2024		
CHK'D	DR. MD. MOSHARRAF HOSSAIN	M M H	18-MAY-2024		
APP'VD	DR. AKM SAIFUL ISLAM	A S I	20-JULY-2024		
THIRD ANGLE PROJECTION:					
					
DWG NO: SFMRA-S3-033					
OUTSOURCING: VENDOR					
MATERIAL: STAINLESS STEEL (FERRITIC)			WEIGHT: N/A		
SCALE: 1:2			SHEET: 74		
			REVISION: A		

N.B: TAKING DECIMAL PLACES: 01

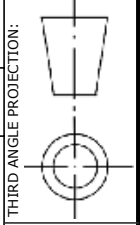

N.B: SHEET THICKNESS 1.5mm.
 ANGLE BAR (25x25x3)mm

N.B: PATTERN OF ANGLE BAR (25x25x3)mm.
 QUANTITY: 09 (LINEARLY)
 LENGTH: 931mm
 SETTING: INSIDE THE CASING.

UNLESS OTHERWISE SPECIFIED: STD. TOLERANCE DIMENSIONS ARE IN MILLIMETER MILLIMETER: ± 0.1 , ANGULAR: $\pm 0.05^\circ$ * DOES NOT APPLY TO HOLE SIZE		 BANGLADESH RICE RESEARCH INSTITUTE SFMRA PROJECT, FMPHT DIVISION		DO NOT SCALE DRAWING	
DETAILS		NAME	SIGNATURE	DATE	FINISH: NONE
DRAWN	ENGR. SHAFTER JAHAN KHAN	S J K	15-MAY-2024		FIRST ISSUED: 15-APR-2024
CHK'D	DR. MD. MOSHARRAF HOSSAIN	M H H	18-MAY-2024		
APP'VD	DR. AKM SAIFUL ISLAM	A S I	20-JULY-2024		
THIRD ANGLE PROJECTION:					
		TITLE: BRRI RICE-WHEAT THRESHER (BRRI TH2023) DRG. NAME: CLEANER DWG NO: SFMRA-S3-034 MANUFACTURING METHOD: MACHINING, BENDING & WELDING MATERIAL: PLAIN CARBON STEEL WEIGHT: 22241.62 g SCALE: 1:10 SHEET: 75 REVISION: A			

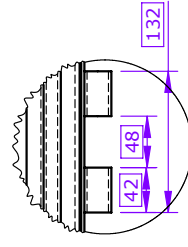

N.B: TAKING DECIMAL PLACES: 01



BEARING TYPE: **BALL BEARING**
 MODEL: **SKF 6202 BALL BEARING**
 INNER DIAMETER: 15mm
 OUTER DIAMETER: 35mm

UNLESS OTHERWISE SPECIFIED: STD. TOLERANCE DIMENSIONS ARE IN MILLIMETER MILLIMETER: ± 0.1, ANGULAR: ±0.05° * DOES NOT APPLY TO HOLE SIZE			BANGLADESH RICE RESEARCH INSTITUTE		DO NOT SCALE DRAWING
			SFMRA PROJECT, FMPHT DIVISION		
TITLE: BRRRI RICE-WHEAT THRESHER (BRRRI TH2023)			FIRST ISSUED: 15-APR-2024		
DRG. NAME: BEARING_6202			DWG NO: SFMRA-S3-035		
OUTSOURCING: VENDOR			SCALE: 2:1		
MATERIAL: N/A			WEIGHT: N/A		
SHEET: 76			REVISION: A		

DETAILS	NAME	SIGNATURE	DATE
DRAWN	ENGR. SHAFTER JAHAN KHAN	S J K	15-MAY-2024
CHKD	DR. MD. MOSHARRAF HOSSAIN	M M H	18-MAY-2024
APPVD	DR. AKM SAIFUL ISLAM	A S I	20-JULY-2024

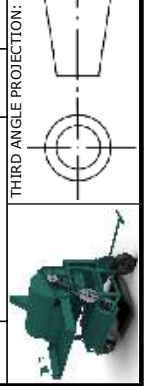

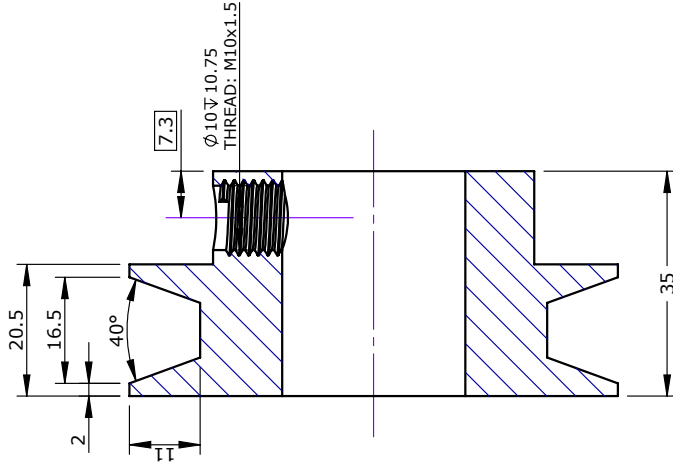
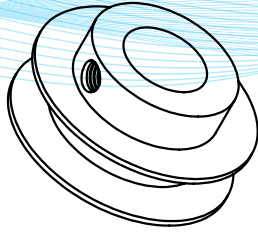

N.B: TAKING DECIMAL PLACES: 01

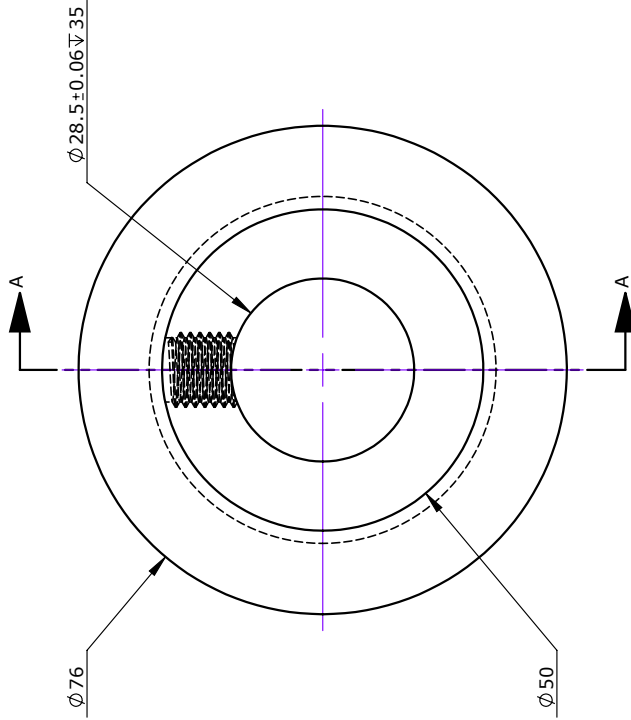

SECTION A-A
SCALE 1 : 1

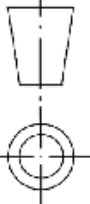

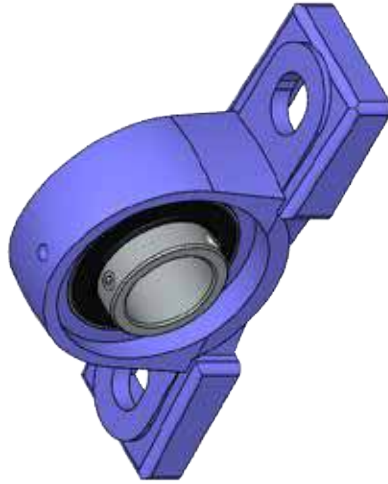

UNLESS OTHERWISE SPECIFIED: STD. TOLERANCE DIMENSIONS ARE IN MILLIMETER MILLIMETER: ± 0.1, ANGULAR: ±0.05° * DOES NOT APPLY TO HOLE SIZE			BANGLADESH RICE RESEARCH INSTITUTE		DO NOT SCALE DRAWING
			SFMRA PROJECT, FMPHT DIVISION		FINISH: NONE FIRST ISSUED: 15-APR-2024
DETAILS	NAME	SIGNATURE	DATE	TITLE: BRRI RICE-WHEAT THRESHER (BRRI TH2023)	
DRAWN	ENGR. SHAFFER JAHAN KHAN	S J K	15-MAY-2024	DRG. NAME: BLOWER PULLEY: V-GROOVE, TYPE-B	
CHK'D	DR. MD. MOHARRAF HOSSAIN	M M H	18-MAY-2024	DWG NO: SFMRA-S4-036	
APP'VD	DR. AKM SAIFUL ISLAM	A S I	20-JULY-2024	MANUFACTURING METHOD: MACHINING	
THIRD ANGLE PROJECTION:					
			MATERIAL: GRAY CAST IRON		
SCALE: 1:1			SHEET: 77		REVISION: A

N.B: TAKING DECIMAL PLACES: 01



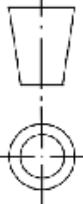

BEARING HOUSING:
UCP-206
QUANTITY: 02
 TO BE USED ON THE BOTH SIDE OF BLOWER SHAFT.

UNLESS OTHERWISE SPECIFIED: STD. TOLERANCE DIMENSIONS ARE IN MILLIMETER MILLIMETER: ± 0.1, ANGULAR: ±0.05° * DOES NOT APPLY TO HOLE SIZE				BANGLADESH RICE RESEARCH INSTITUTE SFMRA PROJECT, FMPHT DIVISION		DO NOT SCALE DRAWING FINISH: _____ NONE FIRST ISSUED: 15-APR-2024	
DETAILS NAME DRAWN ENGR. SHAFFER JAHAN KHAN CHK'D DR. MD. MOSHARRAF HOSSAIN APP'VD DR. AKM SAIFUL ISLAM		SIGNATURE S J K M M H A S I		DATE 15-MAY-2024 18-MAY-2024 20-JULY-2024		TITLE: BRRRI RICE-WHEAT THRESHER (BRRRI TH2023) DRG. NAME: UCP206 DWG NO: SFMRA-S4-037 OUTSOURCING: VENDOR MATERIAL: N/A SCALE: 1:2	
		THIRD ANGLE PROJECTION: 		SHEET: 78 REVISION: A		WEIGHT: N/A A4	

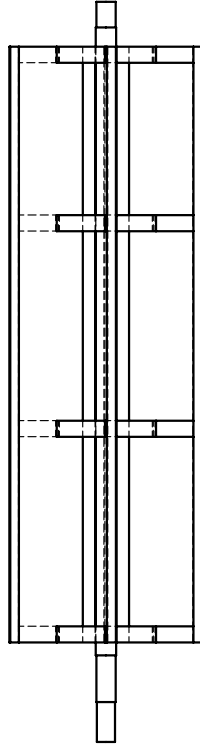
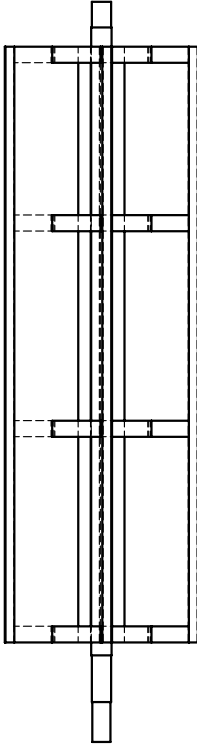
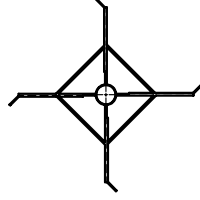
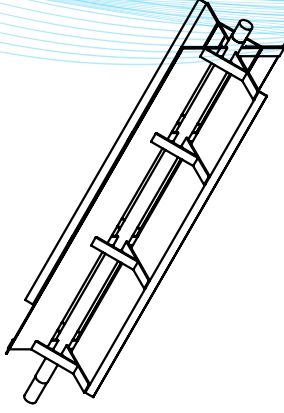
N.B: TAKING DECIMAL PLACES: 01

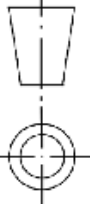

UNLESS OTHERWISE SPECIFIED: STD. TOLERANCE DIMENSIONS ARE IN MILLIMETER MILLIMETER: ± 0.1, ANGULAR: ±0.05° * DOES NOT APPLY TO HOLE SIZE				BANGLADESH RICE RESEARCH INSTITUTE SFMRA PROJECT, FMPHT DIVISION		DO NOT SCALE DRAWING	
DETAILS		NAME	SIGNATURE	DATE	FINISH: NONE		
DRAWN	ENGR. SHAFTER JAHAN KHAN	S J K		15-MAY-2024	FIRST ISSUED: 15-APR-2024		
CHK'D	DR. MD. MOSHARRAF HOSSAIN	M M H		18-MAY-2024	TITLE: BRRRI RICE-WHEAT THRESHER (BRRRI TH2023)		
APP'VD	DR. AKM SAIFUL ISLAM	A S I		20-JULY-2024	DRG. NAME: BLOWER_FAN		
THIRD ANGLE PROJECTION:				DWG NO: SFMRA-S4-038			
				MANUFACTURING METHOD: MACHINING, BENDING & WELDING			
				MATERIAL: PLAIN CARBON STEEL			
				SCALE: 1:10			
				SHEET: 79			
				REVISION: A			

N.B: NOT A COMPLETE DRAWING.
 N.B: SHEET NO. (79-81) REPRESENTING **BLOWER_FAN**.
 N.B: SHEET THICKNESS 1.5mm.
 N.B: TAKING DECIMAL PLACES: 01

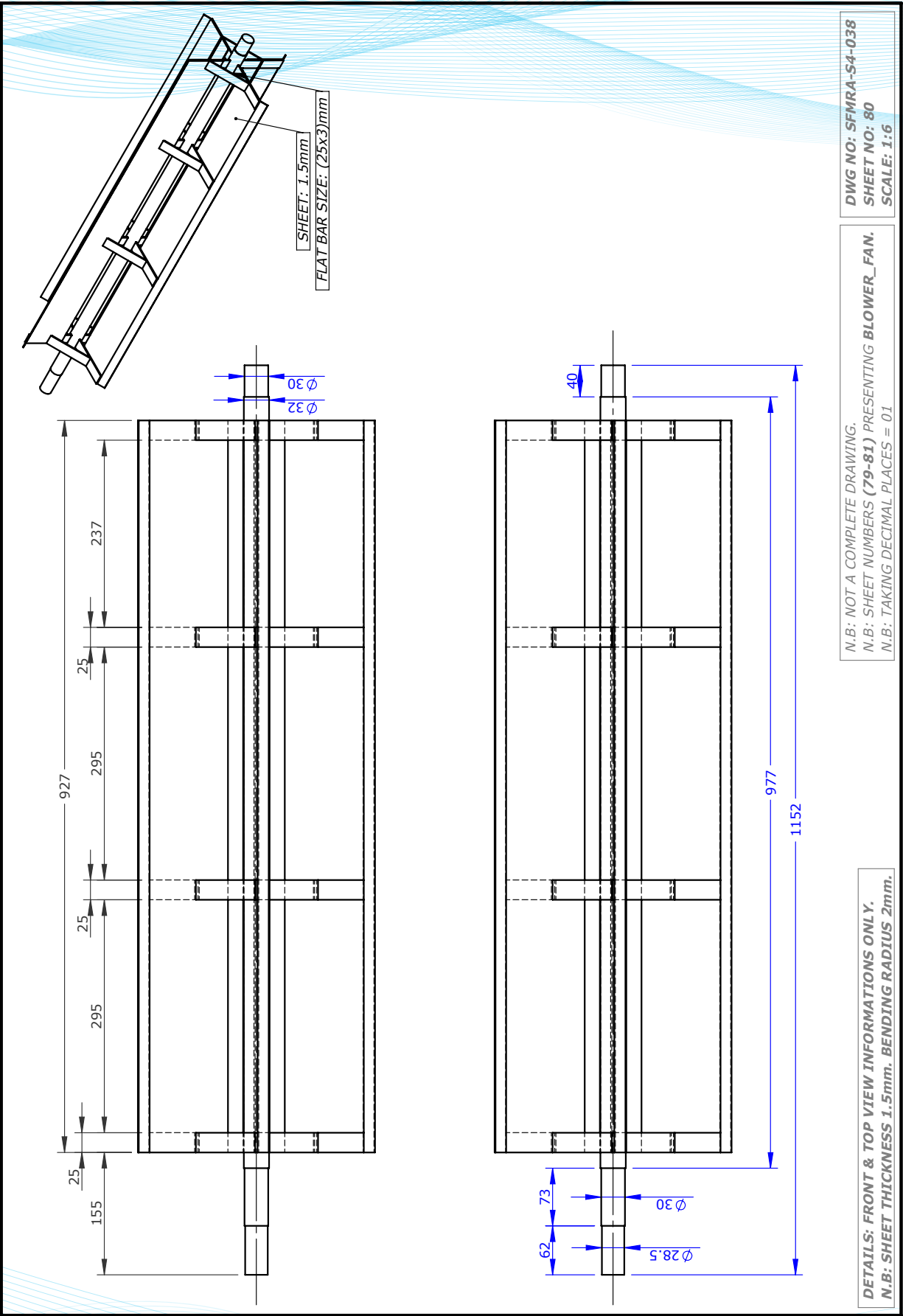

DWG NO: SFMRA-S4-038
SHEET NO: 80
SCALE: 1:6

N.B: NOT A COMPLETE DRAWING.
N.B: SHEET NUMBERS (79-81) REPRESENTING BLOWER_FAN.
N.B: TAKING DECIMAL PLACES = 01

DETAILS: FRONT & TOP VIEW INFORMATIONS ONLY.
N.B: SHEET THICKNESS 1.5mm. BENDING RADIUS 2mm.

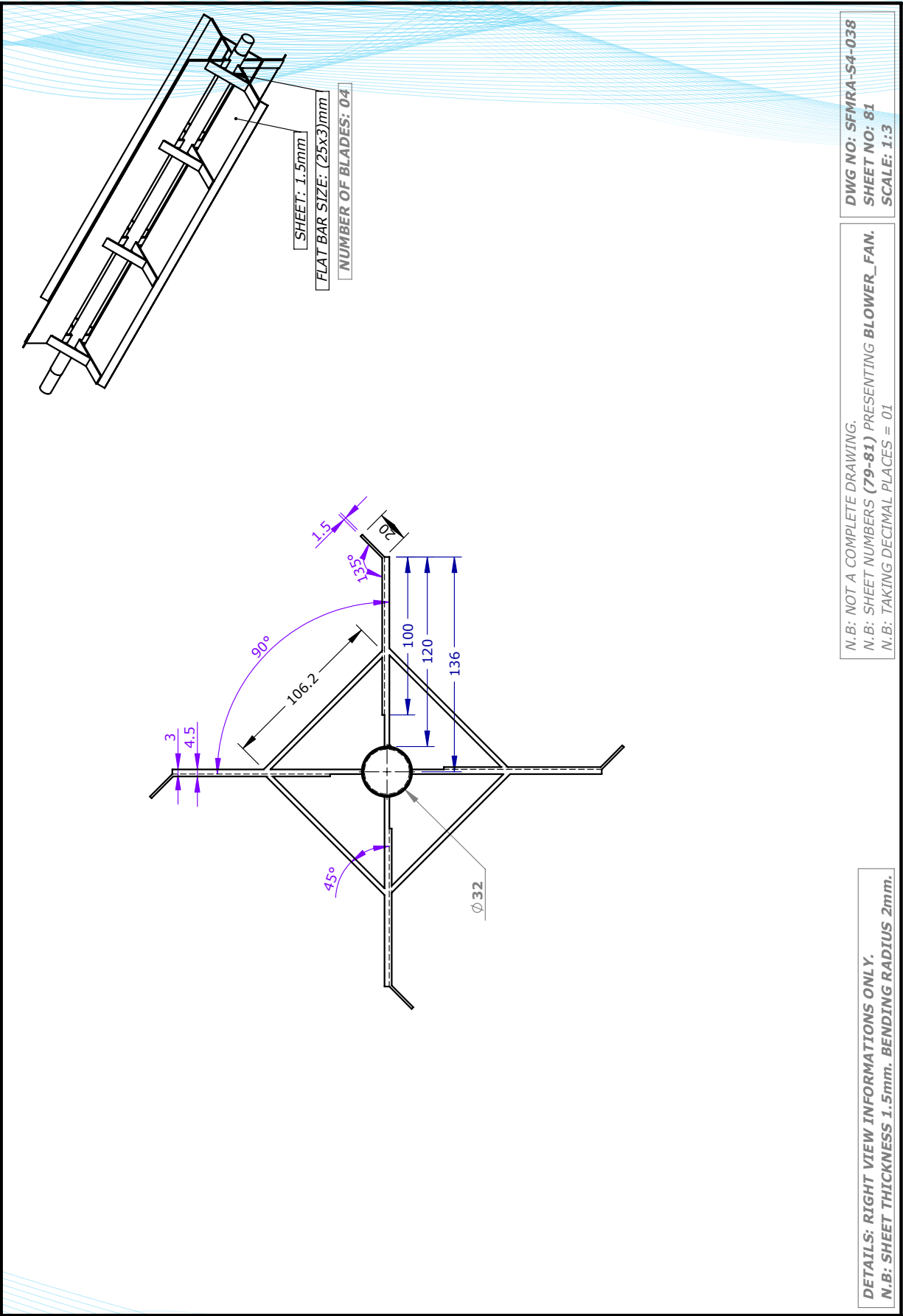



DWG NO: SFMRA-S4-038
 SHEET NO: 81
 SCALE: 1:3

N.B: NOT A COMPLETE DRAWING.
 N.B: SHEET NUMBERS (79-81) PRESENTING BLOWER_FAN.
 N.B: TAKING DECIMAL PLACES = 01

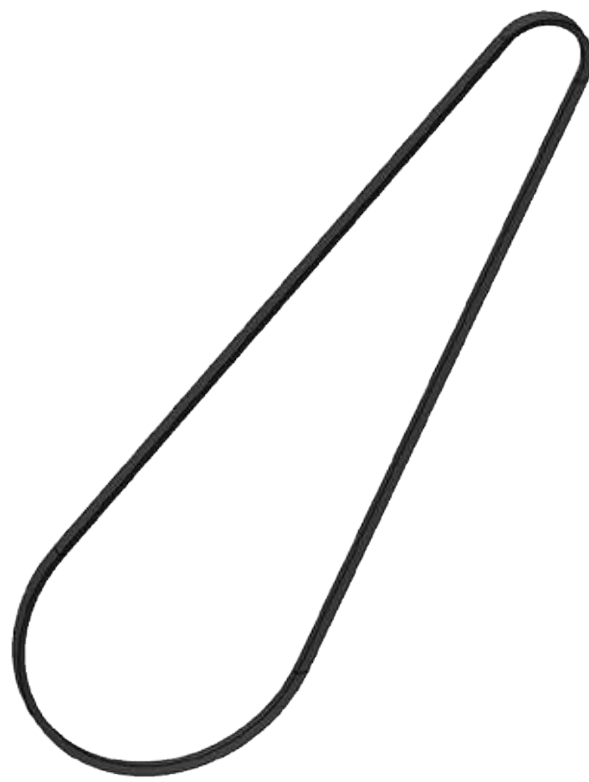
DETAILS: RIGHT VIEW INFORMATIONS ONLY.
 N.B: SHEET THICKNESS 1.5mm. BENDING RADIUS 2mm.



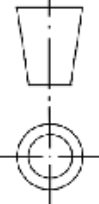

V-BELT TYPE-B MODEL NO: B-76

UNLESS OTHERWISE SPECIFIED: STD. TOLERANCE DIMENSIONS ARE IN MILLIMETER MILLIMETER: ± 0.1, ANGULAR: ±0.05° * DOES NOT APPLY TO HOLE SIZE			BANGLADESH RICE RESEARCH INSTITUTE SFMRA PROJECT, FMPHT DIVISION		DO NOT SCALE DRAWING
					FINISH: NONE FIRST ISSUED: 15-APR-2024
DETAILS NAME DRAWN ENGR. SHAFIET JAHAN KHAN CHK'D DR. MD. MOSHARRAF HOSSAIN APP'VD DR. AKM SAIFUL ISLAM		SIGNATURE S J K M M H A S I	DATE 15-MAY-2024 18-MAY-2024 20-JULY-2024	TITLE: BRRI RICE-WHEAT THRESHER (BRRI TH2023) DRG. NAME: V-BELT TYPE-B MODEL NO: B-76 DWG NO: SFMRA-S4-039	
		THIRD ANGLE PROJECTION: 		OUTSOURCING: VENDOR	
				MATERIAL: RUBBER SCALE: 1:6 SHEET: 82	
				WEIGHT: N/A	REVISION: A

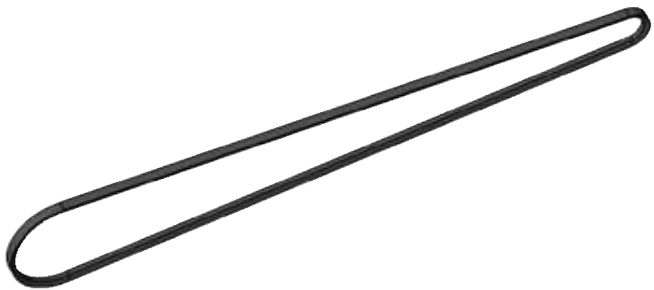
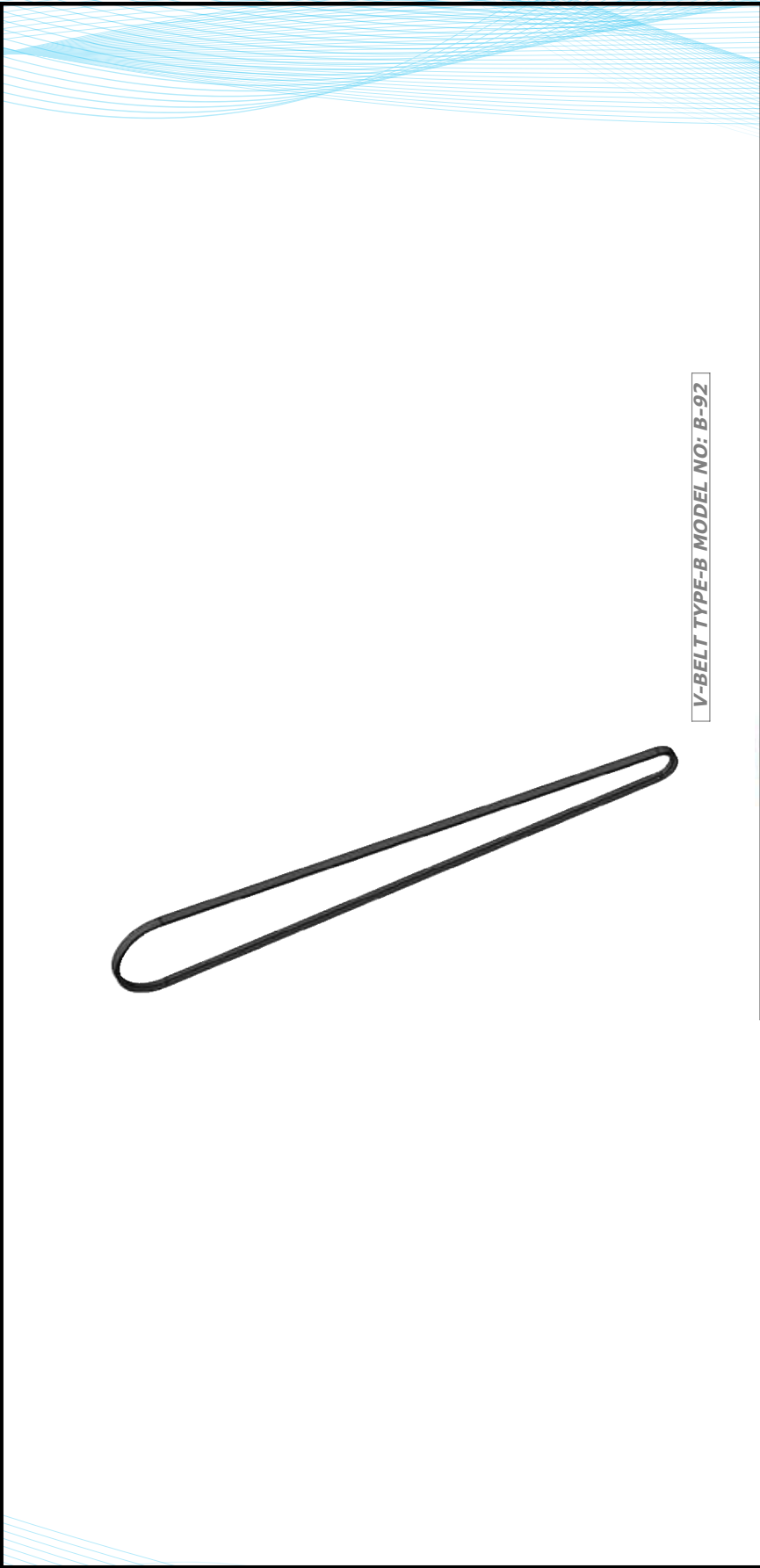
N.B: TAKING DECIMAL PLACES: 01

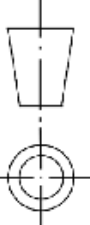

V-BELT TYPE-B MODEL NO: B-92

UNLESS OTHERWISE SPECIFIED: STD. TOLERANCE DIMENSIONS ARE IN MILLIMETER MILLIMETER: ± 0.1, ANGULAR: ±0.05° * DOES NOT APPLY TO HOLE SIZE			BANGLADESH RICE RESEARCH INSTITUTE		DO NOT SCALE DRAWING																	
			SFMRA PROJECT, FMPHT DIVISION		FINISH: NONE FIRST ISSUED: 15-APR-2024																	
<table border="1"> <thead> <tr> <th>DETAILS</th> <th>NAME</th> <th>SIGNATURE</th> <th>DATE</th> </tr> </thead> <tbody> <tr> <td>DRAWN</td> <td>ENGR. SHAFIET JAHAN KHAN</td> <td>S J K</td> <td>15-MAY-2024</td> </tr> <tr> <td>CHK'D</td> <td>DR. MD. MOSHARRAF HOSSAIN</td> <td>M M H</td> <td>18-MAY-2024</td> </tr> <tr> <td>APP'VD</td> <td>DR. AKM SAIFUL ISLAM</td> <td>A S I</td> <td>20-JULY-2024</td> </tr> </tbody> </table>			DETAILS	NAME	SIGNATURE	DATE	DRAWN	ENGR. SHAFIET JAHAN KHAN	S J K	15-MAY-2024	CHK'D	DR. MD. MOSHARRAF HOSSAIN	M M H	18-MAY-2024	APP'VD	DR. AKM SAIFUL ISLAM	A S I	20-JULY-2024	TITLE: BIRRI RICE-WHEAT THRESHER (BIRRI TH2023)			
DETAILS	NAME	SIGNATURE	DATE																			
DRAWN	ENGR. SHAFIET JAHAN KHAN	S J K	15-MAY-2024																			
CHK'D	DR. MD. MOSHARRAF HOSSAIN	M M H	18-MAY-2024																			
APP'VD	DR. AKM SAIFUL ISLAM	A S I	20-JULY-2024																			
			DRG. NAME: V-BELT TYPE-B MODEL NO: B-92																			
THIRD ANGLE PROJECTION:																						
			DWG NO: SFMRA-S4-040																			
			OUTSOURCING: VENDOR																			
			MATERIAL: RUBBER		WEIGHT: N/A																	
			SCALE: 1:10		SHEET: 83																	
					REVISION: A																	

N.B: TAKING DECIMAL PLACES: 01

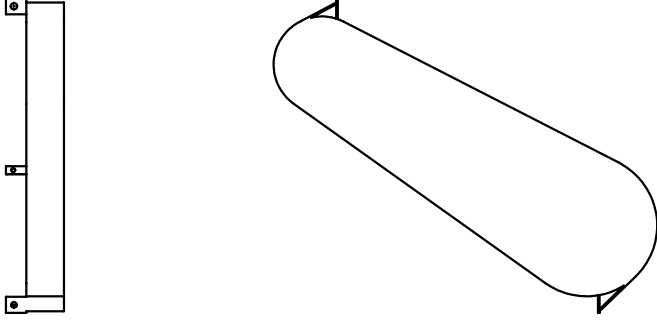

NOTE: VIEW SHEET 87 FOR DETAILS,
SHEET THICKNESS: 2mm
FLAT BAR: (50x5)mm
FLAT BAR: (25x3)mm

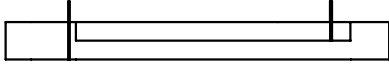
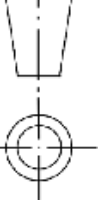

THIRD ANGLE PROJECTION:

UNLESS OTHERWISE SPECIFIED:
STD. TOLERANCE
DIMENSIONS ARE IN MILLIMETER
MILLIMETER: ± 0.1, ANGULAR: ±0.05°
* DOES NOT APPLY TO HOLE SIZE

BANGLADESH RICE RESEARCH INSTITUTE
SFMRA PROJECT, FMPHT DIVISION

DETAILS

NAME	SIGNATURE	DATE
DRAWN ENGR. SHAFFER JAHAN KHAN	S J K	15-MAY-2024
CHK'D DR. MD. MOSHARRAF HOSSAIN	M M H	18-MAY-2024
APP'VD DR. AKM SAIFUL ISLAM	A S I	20-JULY-2024

DO NOT SCALE DRAWING

FINISH: NONE

FIRST ISSUED: 15-APR-2024

TITLE: BRRRI RICE-WHEAT THRESHER (BRRRI TH2023)

DRG. NAME: THRESHER_SAFETY_CASING

DWG NO: SFMRA-S4-041

MANUFACTURING METHOD: MACHINING, BENDING & WELDING

MATERIAL: PLAIN CARBON STEEL

SCALE: 1:20

WEIGHT: 12041.91 g

SHEET: 84

REVISION: A

N.B: NOT A COMPLETE DRAWING.
N.B: SHEET NO. (84-87) PRESENTING
THRESHER_SAFETY_CASING.
N.B: SHEET THICKNESS 2mm.
N.B: TAKING DECIMAL PLACES: 01

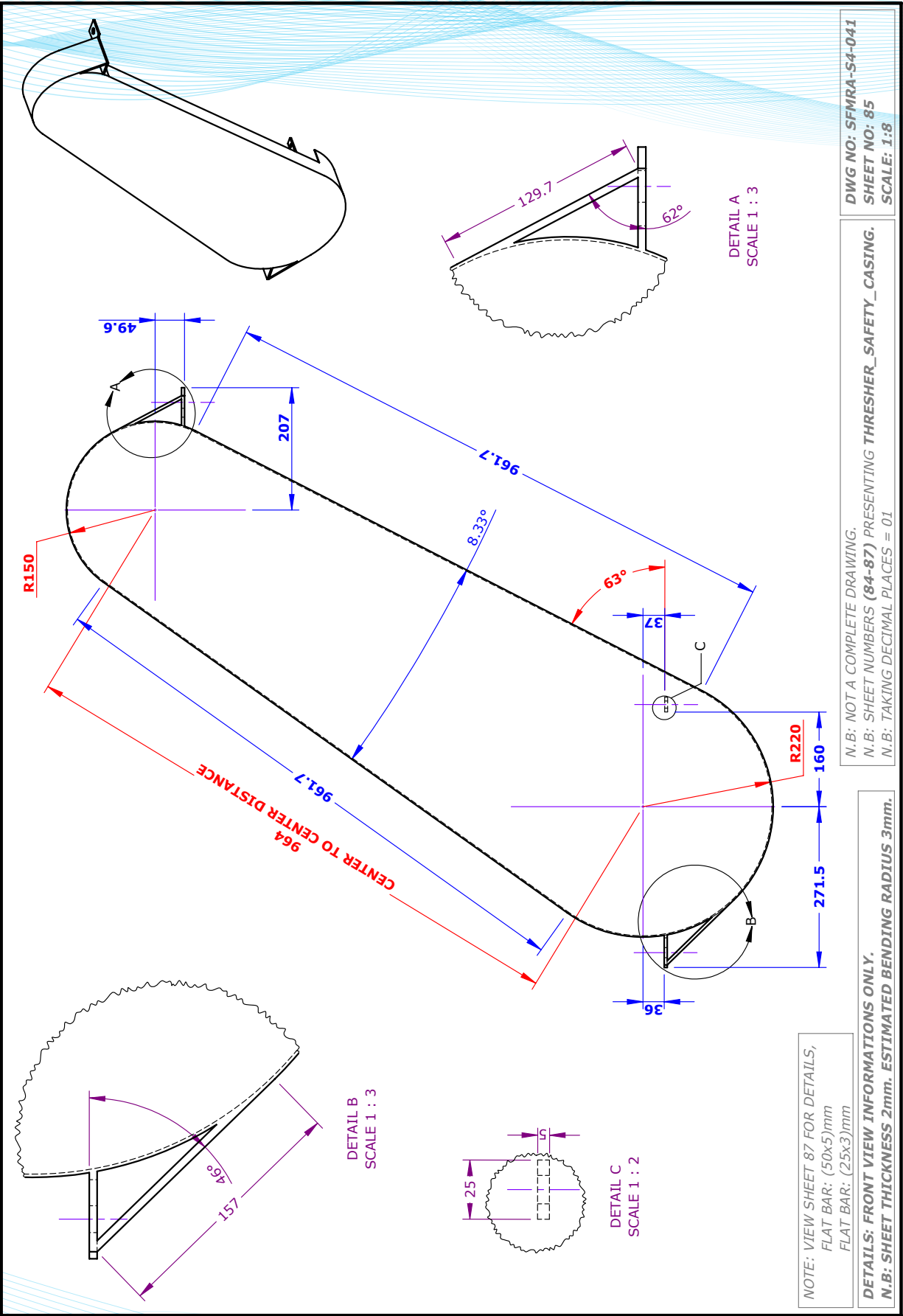

DWG NO: SFMRA-S4-041
 SHEET NO: 85
 SCALE: 1:8

N.B.: NOT A COMPLETE DRAWING.
 N.B.: SHEET NUMBERS (84-87) PRESENTING THRESHER SAFETY CASING.
 N.B.: TAKING DECIMAL PLACES = 01

NOTE: VIEW SHEET 87 FOR DETAILS,
 FLAT BAR: (50x5)mm
 FLAT BAR: (25x3)mm
 DETAILS: FRONT VIEW INFORMATIONS ONLY.
 N.B.: SHEET THICKNESS 2mm. ESTIMATED BENDING RADIUS 3mm.

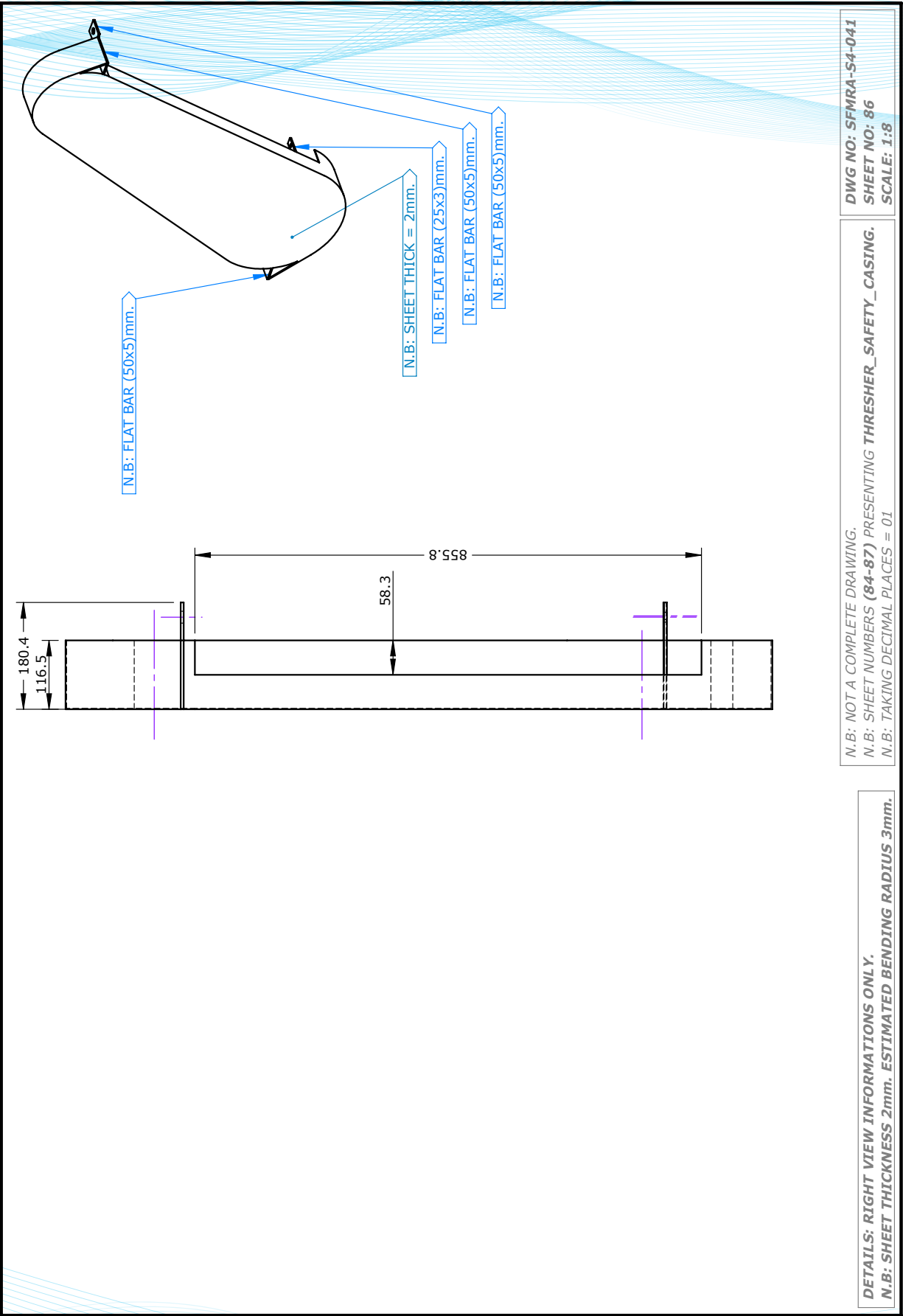

DWG NO: SFMRA-S4-041
 SHEET NO: 86
 SCALE: 1:8

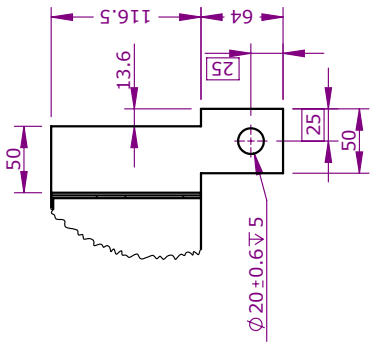

DETAIL G
SCALE 1 : 5

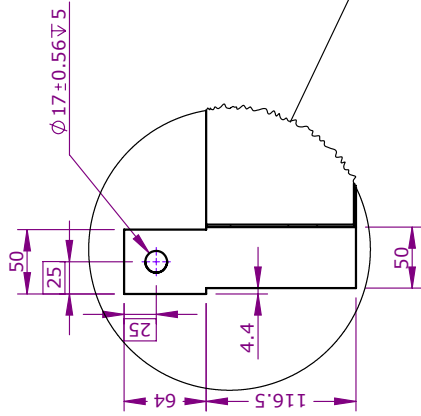

DETAIL F
SCALE 1 : 5

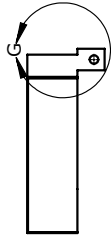

SECTION D-D
SCALE 1 : 15

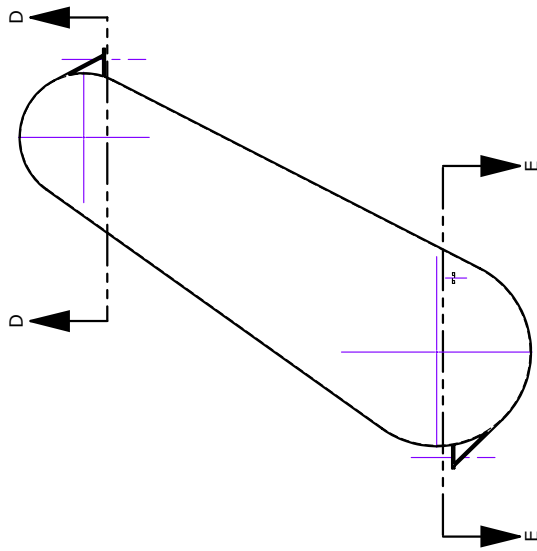

SECTION E-E
SCALE 1 : 15

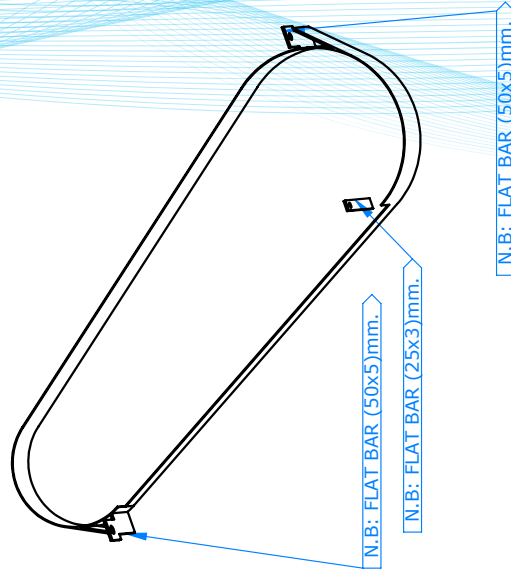
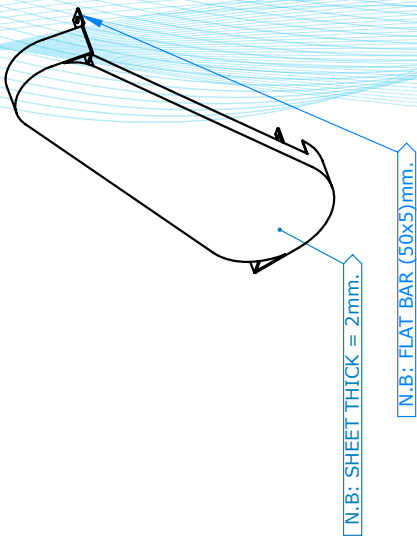
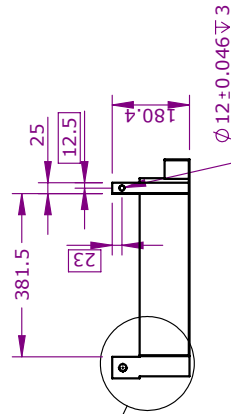

BACK ISOMETRIC VIEW

DWG NO: SFMRA-S4-041
SHEET NO: 87
SCALE: 1:15

N.B.: NOT A COMPLETE DRAWING.
N.B.: SHEET NUMBERS (84-87) PRESENTING THRESHER_SAFETY_CASING.
N.B.: TAKING DECIMAL PLACES = 01

DETAILS: SECTION VIEWS FROM (FRONT VIEW) INFORMATIONS ONLY.
N.B.: SHEET THICKNESS 2mm. ESTIMATED BENDING RADIUS 3mm.

