

# Design Overview: BRRI mini rice huller (Model BRRI RM2024B)

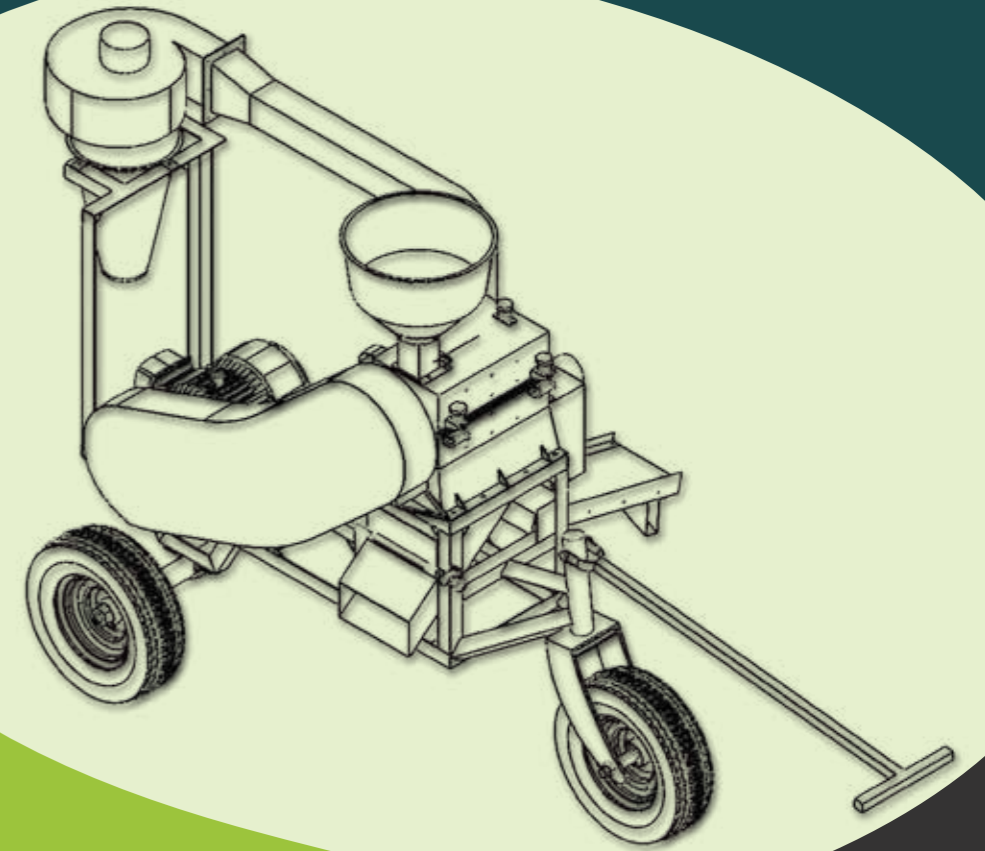

Design Overview: BRRI mini rice huller (Model BRRI RM2024B)

AKM Saiful Islam

AKM Saiful Islam



**Bangladesh Rice Research Institute**

# **Design Overview: BRRI mini rice huller (Model BRRI RM2024B)**



**AKM Saiful Islam**

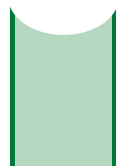

**First published** : July 2024

**Publication no.** : 407

**Number of copies** : 300

**Copyright** : **Bangladesh Rice Research Institute**

**Cover page design** : **Dr. AKM Saiful Islam**

**Communication** : Publication and Public Relation Division  
Bangladesh Rice Research Institute, Gazipur  
Bangladesh

**Printed by** : **Tithy Printing & Packaging**  
28/C-1, Toyenbee Circular Road, Motijheel C/A  
Dhaka-1000, Cell : 01819263481

**Engineering drawing**

**Drawn by** : **Shafier Jahan Khan**  
Mechanical Engineer, B.Sc. (Hons.)  
Research Assistant, SFMRA project.  
Bangladesh Rice Research Institute (BRRI)

**Checked by** : **Professor Dr. Md. Mosharraf Hossain**  
Department of Farm Power and Machinery  
Bangladesh Agricultural University

**Approved by** : **Dr. AKM Saiful Islam**  
Chief Scientific Officer  
Farm Machinery and Postharvest Technology Division  
Bangladesh Rice Research Institute

**Citation :**

Islam, AKM Saiful 2024: Design overview: BRRI mini rice huller (Model BRRI RM2024B).  
Publication no. 407, Bangladesh Rice Research Institute, Gazipur, Bangladesh

**Acknowledgment:**

Special thanks to all those who directly and indirectly helped in the preparation of this book.

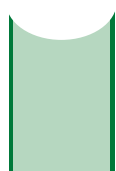

## Preface

The function of BIRRI mini rice huller mill is to de-husk rice efficiently in a single pass through an Engelberg huller. By incorporating a cyclone separator, this machine ensures that clean rice is obtained in one pass, while also maintaining a low rice temperature throughout the process. This combination of features makes the BIRRI mini huller mill a reliable and efficient solution for rice processing needs. The BIRRI mini rice huller (BIRRI RM2024B) is scale-up version of its predecessor model (BIRRI RM2024A). The publication named "Design Overview: BIRRI Mini Rice Huller (BIRRI RM2024B)" represents a comprehensive guide meticulously crafted for local farm machinery manufacturers aiming to produce high-quality rice hullers tailored to the needs of their communities. Local farm machinery manufacturers play a pivotal role in providing farmers with the tools necessary to enhance productivity and sustainability in agriculture. However, the design and production of these machines require a deep understanding of engineering principles and manufacturing techniques. This book serves as a beacon of knowledge for such manufacturers, offering a detailed exploration of the design aspects essential for producing top-tier rice hullers. From assembly and subassembly drawings to part details and bill of materials, each chapter provides manufacturers with the insights and guidance needed to produce machines of exceptional quality. Moreover, this design overview emphasizes the importance of quality control and precision manufacturing in ensuring the reliability and longevity of the rice huller. We extend our deepest appreciation to the dedicated professionals committed to advancing agricultural machinery manufacturing.





**Director General**  
**Bangladesh Rice Research Institute**

## Foreword

The Farm Machinery and Postharvest Technology Division of the Bangladesh Rice Research Institute is currently executing the project named "Strengthening Farm Machinery Research Activity for Mechanized Rice Cultivation (SFMRA)". Under the supervision of Dr. AKM Saiful Islam, Agricultural Engineers of BRRRI developed the mini rice huller using indigenous raw materials in a local workshop. It is with great pleasure and enthusiasm that I provide the foreword for "Design Overview: BRRRI mini rice huller (BRRRI RM2024B)," compiled by the esteemed Dr. AKM Saiful Islam. The BRRRI mini rice huller (BRRRI RM2024B) represents a significant advancement in rice processing technology, building upon the success of its predecessor model (BRRRI RM2024A). Dr. Islam's comprehensive exploration of the assembly and subassembly drawings, part details, and bill of materials provides invaluable insights for engineers, manufacturers, and researchers seeking to understand the intricacies of the BRRRI mini huller rice mill. His dedication to agricultural engineering and his profound expertise in the field make him an ideal compiler for this comprehensive guide on rice huller design. It is my sincere belief that this book will serve as a cornerstone for further innovation and progress in the field of rice processing technology. I extend my gratitude to Dr. Islam for his commitment to advancing agricultural engineering. It is my privilege to endorse this compilation and to commend Dr. Islam for his outstanding contributions to the field.

A handwritten signature in blue ink, consisting of stylized initials and a surname.

(Dr. Md. Shahjahan Kabir)

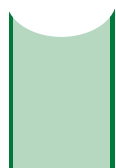



**Chief Scientific Officer**  
**Farm Machinery and Postharvest Technology Division**  
**BRRRI, Gazipur**

## **About Project Director**

Dr. AKM Saiful Islam graduated from the Department of Farm Power and Machinery, Bangladesh Agricultural University, Mymensingh and received chancellor award for achieving first position in graduate course. Dr Islam obtained MS degree from the same university in 1996. He completed a postgraduate diploma course from Silsoe College, UK in 1997. DR Islam obtained PhD in Agricultural Engineering from the Department of Farm Power and Machinery, Bangladesh Agricultural University, Mymensingh in 2012. He started his career as a Scientific Officer in Farm Machinery and Postharvest Technology Division of Bangladesh Rice Research Institute in 1998. Dr. Islam developed training manual for seedling raising techniques, BRRRI weeder, rice-wheat reaper, BRRRI open drum thresher, BRRRI rice-wheat thresher, BRRRI panicle thresher, BRRRI whole feed combine harvester. He is involved in the invention and development of mechanized seedling raising techniques, BRRRI seed sower, BRRRI auto seed sower, BRRRI rice transplanter, BRRRI semi automatic rice transplanter, BRRRI solar light trap, BRRRI urea super granular fertilizer, BRRRI power weeder, BRRRI rice-wheat reaper, BRRRI rice-wheat thresher, BRRRI panicle thresher, BRRRI whole feed combine harvester, BRRRI head feed combine harvester, BRRRI straw rope maker, BRRRI air blow rice mill, BRRRI compact rice mill, BRRRI mini rice huller and BRRRI short and long rice processing technology. At present, he is working as a Chief Scientific Officer and project director of the project "Strengthening Farm Machinery Research Activity for Mechanized Rice Cultivation (SFMRA)".

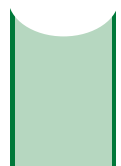

## About project

The project "Strengthening Machinery Research Activity for Mechanized Rice Cultivation" was approved for implementation from July 2019 to June 2025 at an estimated cost of Tk 4400 Lakhs. The project is being implemented by the Farm Machinery and Postharvest Technology Division of Bangladesh Rice Research Institute under the Ministry of Agriculture in 12 upazilas of 12 districts of seven divisions of the country. One of the main objectives of the project is to strengthen farm machinery research activities for sustainable rice cultivation. The specific objectives of the project are (a) Developing nine agricultural machinery and technologies suitable to the socio-economic condition of the farmers: i.e. rice transplanter, mini combine harvester, power weeder, reaper binder, compact rice mills, rice transplanter-cum-fertilizer, straw rope maker, seed sower machines, post-harvest management and renewable energy (solar and briquette machines); (b) Further development of the machinery by collecting feedback from the stakeholder through 324 adaptive trials; (c) Providing hands-on training to 6480 machine operators, farmers, mechanics and service providers and 200 local agricultural machinery manufacturers and extension officers/workers to increase their skills on modern agricultural machinery; (d) Capacity building of 20 scientists and 20 workshop workers for the research on modern agricultural machinery through higher education and training; and (e) Modernization of existing farm machinery research lab-cum-workshop. The project activities are a) Developing nine agricultural machinery and post-harvest technologies suitable for sustainable rice production i.e. rice transplanter, combine harvester, power weeder, reaper binder, compact rice mill, rice transplanter-cum-fertilizer, straw rope maker, seed sower machine, post-harvest management and renewable energy (solar and briquette machines); b) To procure prototypes from abroad and preparing indigenously adapted machines through reverse engineering and applied research; c) To develop machine according to the feedback obtained through practical field tests; d) To Conduct 324 two-day residential hands-on training on seedling raising techniques, operation, repair and maintenance of rice transplanters for mechanized rice transplanting; e) To sensitize 6480 farmers, machine operators, mechanics, farmer groups/farmers associations, service providers about utility of agricultural machinery, operating techniques, repair and maintenance through 324 practical field tests of BRRI developed modern machinery; f) To publish the training schedule and names of the trainees in the form of a database on the BRRI web site to maintain transparency and accountability in the training program and to avoid duplicity in the selection of trainees; g) Developing 10 skilled scientific manpower through three months of overseas training; h) To organize short term (7-10 days) training of 10 scientists in agricultural machinery manufacturing countries; j) Conducting 10 trainings of three days duration on transfer of machinery technology to the farm machinery manufacturers/extension officers/workers; j) To enhance quality research skills by establishing machine testing lab (375 square meters) with modern equipment for machinery quality control; k) Develop a commercial approach to agriculture through limited long-term use of farm machinery and rental machinery service providers in the project area; l) Building co-operation between researchers, extension workers, manufacturers and farmers; d) Development of 2,500 cubic meter research field/plot for head office research; d) Vertical extension (450 square meters) of farm machinery lab cum office building at head office; n) Construction of machinery display cum ware house (150 sq m to 750 sq m in 5 Regional stations) for display room at BRRI Regional stations; (v) Skilling of 20 workshop workers through training in machine prototyping, repair and maintenance; d) To provide necessary technical assistance to the entrepreneurs and machinery manufacturing institutions/factories serving through the Department of Agriculture Extension for ensuring the use of sustainable agricultural machinery at the field level. Recruiting 11 persons (one office assistant cum computer programmer, two bench mechanics, two lathe-operators, two tin smiths, two hammer men and two drivers) through outsourcing to support the project director in project execution. Scientists of FMPHT division, research assistants, Accountant of Accounts division and staff of Planning and Evaluation Division are working on the project as additional responsibilities.

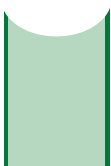

# **BRRI mini rice huller machine**

**(Model: BRRI RM2024B)**

## **Purpose**

**To dehusk paddy in one pass:** This suggests efficiency in the dehusking process, emphasizing the importance of completing the task in a single operation. This could lead to time and resource savings.

**To produce better quality rice:** The goal is to improve the quality of the rice produced, indicating a focus on enhancing the end product's taste, appearance, or nutritional value.

**To operate by women/men or anyone with less education:** The machine is user-friendly and require minimal training, making it accessible to individuals with varying levels of education.

**To dehusk paddy by going door to door:** This suggests a portable solution that can be taken directly to the source, offering convenience to farmers who may not have easy access to centralized processing facilities.

**To help build rural entrepreneurship:** This purpose indicates a broader socio-economic goal. The aim is to empower individuals in rural areas by providing a service that supports paddy dehusking, potentially leading to the development of small businesses or entrepreneurship opportunities.

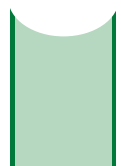

# Characteristics

The BRR mini rice huller (BRR RM2024B) possesses several characteristics that make it efficient and user-friendly.

**Blower and cyclone separator:** The machine is equipped with a blower and cyclone separator, which help in obtaining clean rice in a single pass through the huller.

**Motor Specification:** It is powered by a 7.5 HP motor operating at 1450 rpm, which is designed for single-phase use. Alternatively, a 10 horse power diesel engine can be employed as a substitute for the motor.

**High hulling capacity:** The machine exhibits a substantial hulling capacity, with the ability to hull more than 450 kilograms of paddy per hour. This indicates its efficiency and suitability for processing larger quantities of rice.

**Lower broken rice output:** The amount of broken rice produced by this huller is significantly lower compared to other hullers. This ensures a higher yield of whole rice grains.

**Low rice temperature:** After the hulling process, the temperature of the rice remains low. This is crucial for maintaining the quality of the rice and preventing damage due to excessive heat.

**User-friendly operation:** One of the notable features is its ease of operation. The machine is designed to be operated by individuals with minimal education or training, making it accessible for both men and women.

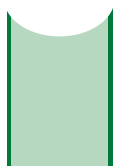

# Specification of BRRI MINI RICE HULLER

**Model: BRRI RM2024B**

Taking, l=length, w=width, h=height, t=thickness,  $\varnothing$ =diameter, r=radius.

1. Machine l=1320mm, h=650 mm, w=500mm. Made of (38x38x3) mm angle bar.
2. Motor casing l=419.5mm, w=90mm. Made of (38x38x3) mm angle bar.
3. Motor is 7.5HP, 1450rpm, single phase 220V.
4. Motor pulley  $\varnothing$ =200mm, t=52mm.
5. Front wheel carrying frame (locally made) wheel  $\varnothing$ =400mm and t=8mm.
6. The machine is moveable with 3 wheels (Size 4.00-8 TIRE).
7. Rim for the following tire model. Rim diameter is 235mm.
8. Square bar for base handle size (25x25x3) mm l=1060mm.
9. Front wheel shaft l=204mm &  $\varnothing$ =25mm.
10. Rear wheel shaft l=1000mm &  $\varnothing$ =45mm.
11. 6205 bearing is used for the mating between axle shaft and rim. Quantity 06 for 3 wheels.
12. Rear axle holder l=155mm, t=8mm.
13. Body upper shell size (w=210, l=405, h=110) mm.
14. Square bar (8x8) mm l=405mm. Quantity 04.
15. Net frame size l=246mm, w=204mm, h=107. Sheet t=3mm. Quantity 02.
16. Shell size r=52mm, l=200mm, t=1.5mm. Quantity 02.
17. Net frame circular shaft  $\varnothing$ =10mm, l=245mm. Quantity 04.
18. Engleburg huller shaft l=619mm,  $\varnothing$ =40mm.
19. Huller shell l=285mm,  $\varnothing$ =92mm.
20. Threaded lock  $\varnothing$ =65mm, h=17mm.
21. Pillow block bearing housing UCP-205. Quantity 02.
22. Husk out line size (l=450, w=325, h=570, t=1.5) mm.
23. Huller pulley (CI) size  $\varnothing$ =247mm, h=59mm.
24. Blower flange  $\varnothing$ =318mm, t=4.5mm.
25. Blower washer  $\varnothing$ =35mm, t=3mm.
26. Blower shaft key size (7x7) mm l=30mm.
27. Blower impeller size  $\varnothing$ =275mm, h=97mm, t=1.5mm.
28. Blower shaft size  $\varnothing$ =31mm, l=571.2mm.
29. Blower size (l=400, w=400, t=1.5) mm area used for the blower. Design is in design pages. Blower h=108mm.
30. Pillow block bearing housing UCP-206 of quantity-02 required for the blower shaft.
31. V-pulley with 3-slots with  $\varnothing$ =146mm, h=91.5mm for blower pulley.
32. (l=804, h=358) mm for the rectangular (80x80x1.5) mm size for the blower to cyclone line part.

33. Cyclone size (l=300, w=400, h=662, t=1.5) mm.
34. Hose pipe (PVC) inner  $\varnothing=82$ mm.
35. Tension shaft  $\varnothing=25$ mm, l=182mm.
36. Tension shaft pulley holder  $\varnothing=31$ mm, l=157mm.
37. Tension bearing 6205 RS, quantity=02.
38. Tension pulley  $\varnothing=98$ mm, h=47mm.
39. Hopper base l=105mm, w=103mm, t=3mm, h=140mm.
40. Hopper size  $\varnothing=455$ mm, h=354mm, t=1.5mm.
41. Grader body size l=500mm, w=240mm, h=75mm, t=1.5mm.
42. Safety guard size l=1150mm, w=801mm, t=1.5mm, h=100mm.
43. V-belt Type-B Belt numbers are B-64, B-48.

## INDEX

SERIAL NO.	DESCRIPTION	SHEET NO.	PAGE NO.
1	ASSEMBLY & SUB-ASSEMBLY	1-16	1
2	S-1 BASE	17-38	17
3	S-2.A BODY UPPER CASING	39-50	39
4	S-2.A BODY BOTTOM CASING	51-72	51
5	S-3 BLOWER TO CYCLONE LINE	73-86	73
6	S-4 TENSION	87-91	87
7	S-5 HOPPER	92-95	92
8	S-6 SIZE GRADER	96-102	96
9	S-7 CLEANING CHAMBER	103-106	103
10	SAFETY GAURD	107-110	107
11	V-BELT TYPE-B MODEL: B-64	111	111
12	V-BELT TYPE-B MODEL: B-48	112	112

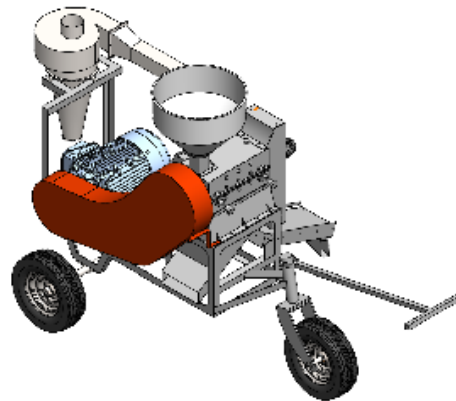
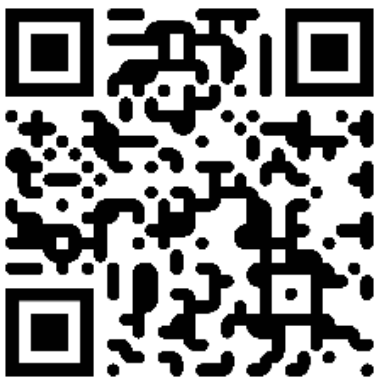

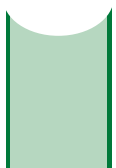

**BILL OF MATERIALS: BRRI MINI RICE HULLER**

ITEM NO.	Description	PartNo	QTY.
1	BASE	SFMRA-S1	1
2	BLOWER TO CYCLONE LINE	SFMRA-S3	1
3	TENSION	SFMRA-S4	1
4	BODY BOTTOM CASING	SFMRA-S2.B	1
5	BODY TOP CAING	SFMRA-S2.A	1
6	SIZE GRADER	SFMRA-S6	1
7	SAFETY GAURD	SFMRA-088	1
8	HOPPER	SFMRA-S5	1
9	CLEANING CHAMBER	SFMRA-S7	1
10	V-BELT TYPE-B MODEL: B-64	SFMRA-089	2
11	V-BELT TYPE-B MODEL: B-48	SFMRA-090	1

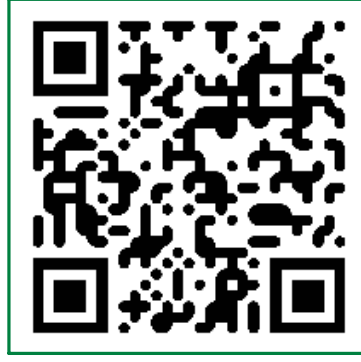
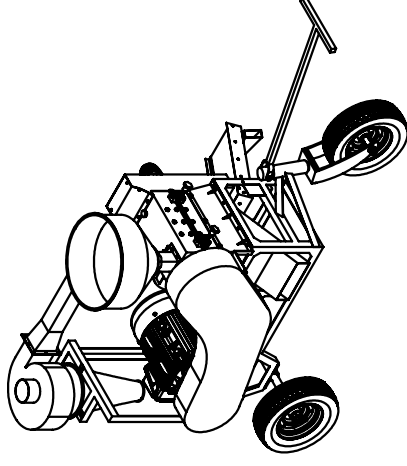

UNLESS OTHERWISE SPECIFIED:  
 STD. TOLERANCE  
 DIMENSIONS ARE IN MILLIMETER  
 MILLIMETER: ±0.1, ANGULAR: ±  
 0.05°  
 \* DOES NOT APPLY TO HOLE SIZE

DETAILS	NAME	SIGNATURE	DATE
DRAWN	ENGR. SHAFER JAHAN KHAN	S J K	28-FEB-2024
CHK'D	DR. MD. MOSHARRAF HOSSAIN	M M H	26-MAR-2024
APP'D	DR. AKMA SAIFUL ISLAM	A S I	30-APR-2024

THIRD ANGLE PROJECTION:

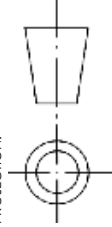

**NOTE:** DEBURR AND BREAK  
 SHARP EDGES ALL BENDS MIN.  
 RADIUS UNLESS SPECIFIED

**BANGLADESH RICE RESEARCH INSTITUTE**  
 SFMRA PROJECT, FMPHT DIVISION

DO NOT SCALE DRAWING  
 FINISH: NONE  
 FIRST ISSUED: 17-FEB-2024

**TITLE: BRRI MINI RICE HULLER (BRRI RM2024B)**

**DRG. NAME: FULL ASSEMBLY**

DWG NO: BRRI RM2024B-A

MANUFACTURING METHOD: MOLDING, MACHINING, BENDING & WELDING

WEIGHT: 213450.55 g

A4

SCALE: 1:75

SHEET 1

REVISION: A

**EXPLODED VIEW - BRRI MINI RICE HULLER**

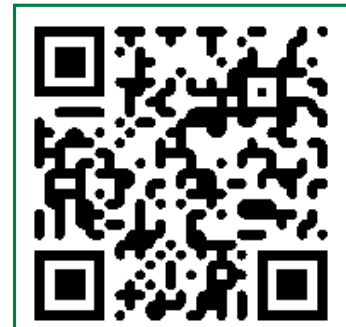
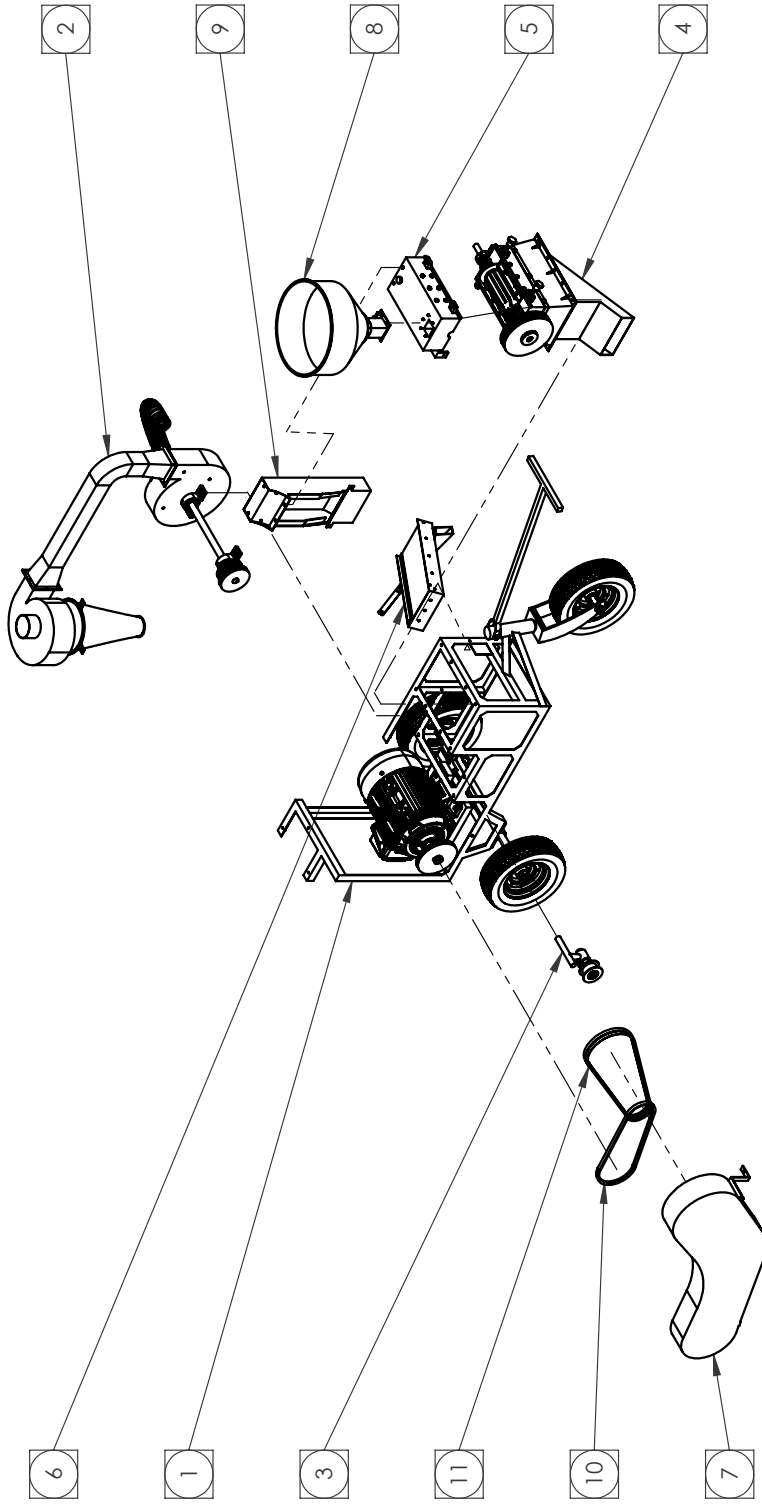

UNLESS OTHERWISE SPECIFIED:  
 STD. TOLERANCE DIMENSIONS ARE IN MILLIMETER  
 MILLIMETER: ±0.1, ANGULAR: ±0.05°  
 \* DOES NOT APPLY TO HOLE SIZE

DETAILS	NAME	SIGNATURE	DATE
DRAWN	ENGR. SHAFER JAHAN KHAN	S J K	28-FEB-2024
CHKD	DR. MD. MOSHARRAF HOSSAIN	M M H	26-MAR-2024
APPVD	DR. AKASAIJUL ISLAM	A S I	30-APR-2024

**BANGLADESH RICE RESEARCH INSTITUTE**  
 SFMRA PROJECT, FMPHT DIVISION

**TITLE: BRRI MINI RICE HULLER (BRRI RM2024B)**  
**DRG. NAME: FULL ASSEMBLY**  
 DWG NO: BRRI\_RM2024B-B  
 MANUFACTURING METHOD: MOLDING, MACHINING, BENDING & WELDING  
 WEIGHT: 213450.55g  
 SCALE: 1:35

DO NOT SCALE DRAWING  
 FINISH: NONE  
 FIRST ISSUED: 17-FEB-2024

**NOTE: DEBURR AND BREAK SHARP EDGES ALL BENDS MIN. RADIUS UNLESS SPECIFIED**



SHEET 2  
 REVISION: A

## BILL OF MATERIALS: BASE

ITEM NO.	Description	PartNo	MATERIAL	QTY.
1	MINI HULLER BASE	SFMRA-S1-001	Plain Carbon Steel	1
2	MOTOR BED	SFMRA-S1-002	Plain Carbon Steel	2
3	FRONT WHEEL CASING	SFMRA-S1-006	Plain Carbon Steel	1
4	BASE HANDLE	SFMRA-S1-004	Plain Carbon Steel	1
5	BASE WHEEL PART - 2 - M10 BOLT-NUT	SFMRA-S1-005	Plain Carbon Steel	1
6	RIM SHAFT FOR FRONT WHEEL	SFMRA-S1-014	Plain Carbon Steel	1
7	WHEEL WASHER - 1 X2	SFMRA-S1-007	Plain Carbon Steel	2
8	WHEEL WASHER - 2 X2	SFMRA-S1-008	Plain Carbon Steel	2
9	WHEEL WASHER - 3 X2	SFMRA-S1-009	Plain Carbon Steel	2
10	WHEEL NUT M14 (FRONT X2)	SFMRA-S1-010	Plain Carbon Steel	2
11	RIM	SFMRA-S1-012	ASTM A36 Steel	3
12	RIM HOLDING PART	SFMRA-S1-013	ASTM A36 Steel	3
13	REAR WHEEL SHAFT	SFMRA-S1-015	Plain Carbon Steel	1
14	6205 RS BEARING - USED IN TENSION	SFMRA-S1-016	Material <not specified>	6
15	WHEEL SHAFT NUT M25 (REAR)	N/A	Stainless Steel (ferritic)	2
16	TIRE A203107R 4-00-8	SFMRA-S1-011	Rubber	3
17	CUSTOM MADE SHAFT HOLDER	SFMRA-S1-017	Plain Carbon Steel	2
18	BASE WHEEL PART - 1	SFMRA-S1-005	Plain Carbon Steel	1
19	MOTOR PULLEY	N/A	Gray Cast Iron	1
20	MOTOR	SFMRA-S1-003	N/A	1

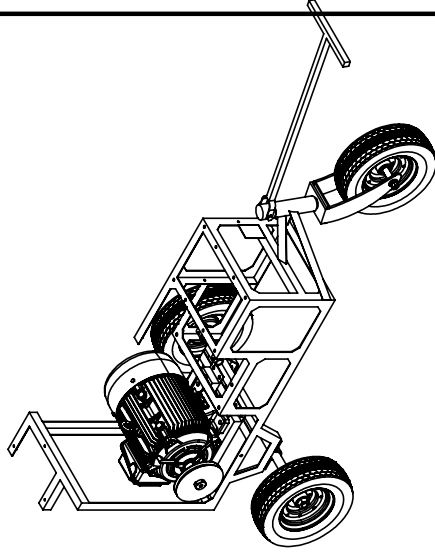

		<b>BANGLADESH RICE RESEARCH INSTITUTE</b> SFMRA PROJECT, FMPHT DIVISION		DO NOT SCALE DRAWING
UNLESS OTHERWISE SPECIFIED: STD. TOLERANCE DIMENSIONS ARE IN MILLIMETER MILLIMETER: ±0.1, ANGULAR: ± 0.05° * DOES NOT APPLY TO HOLE SIZE		DETAILS NAME DRAWN ENGR. SHAFER JAHAN KHAN CHK'D DR. MD. MOSHARRAF HOSSAIN APP'VD DR. AKMA SAIFUL ISLAM	SIGNATURE S J K M M H A S I	FINISH: NONE FIRST ISSUED: 17-FEB-2024
TITLE: BRRI MINI RICE HULLER (BRRI RM2024B)		DRG. NAME: BASE_SUBASSEMBLY		
DWG NO: SFMRA-S1-A		MANUFACTURING METHOD: MOLDING, MACHINING, BENDING & WELDING		
WEIGHT: 97084.88 g		SCALE: 1:25		REVISION: A
SHEET 3		SHEET 3		A

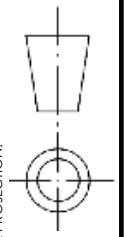

**NOTE:** DEBURR AND BREAK SHARP EDGES ALL BENDS MIN. RADIUS UNLESS SPECIFIED

**EXPLODED VIEW - BASE**

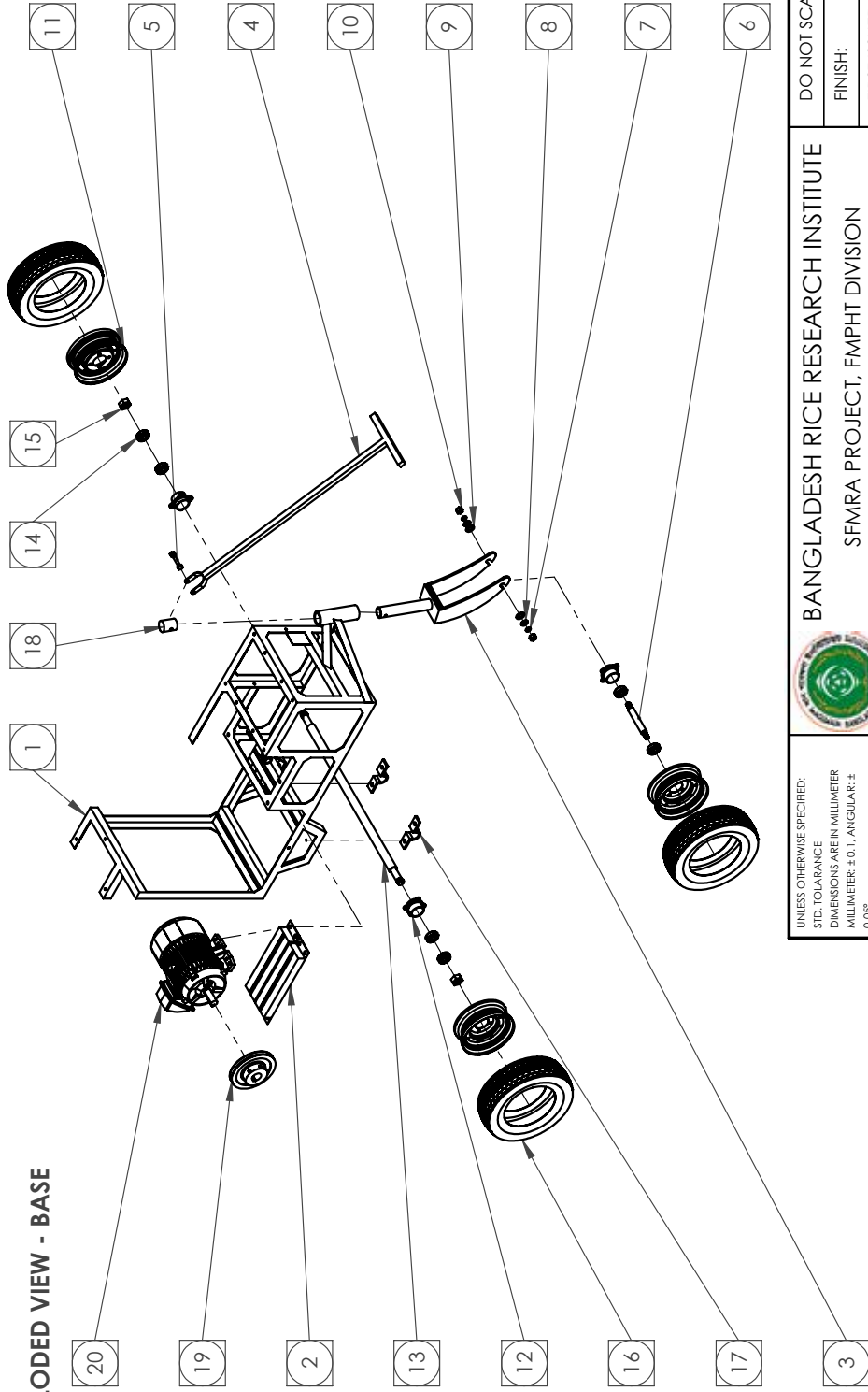

**NOTE:** DEBURR AND BREAK SHARP EDGES ALL BENDS MIN. RADIUS UNLESS SPECIFIED

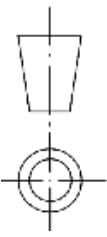
		<b>BANGLADESH RICE RESEARCH INSTITUTE</b> SFMRA PROJECT, FMPHT DIVISION		DO NOT SCALE DRAWING
				FINISH: NONE
UNLESS OTHERWISE SPECIFIED: STD. TOLERANCE DIMENSIONS ARE IN MILLIMETER MILLIMETER: ±0.1, ANGULAR: ±0.05° * DOES NOT APPLY TO HOLE SIZE				FIRST ISSUED: 17-FEB-2024
DETAILS NAME SIGNATURE DATE				
DRAWN ENGR. SHAFIEE JAHAN KHAN		S J K		28-FEB-2024
CHK'D DR. MD. MOSHARRAF HOSSAIN		M M H		26-MAR-2024
APP'VD DR. AKMA SAIFUL ISLAM		A S I		30-APR-2024
THIRD ANGLE PROJECTION:				
TITLE: BRRI MINI RICE HULLER (BRRI RM2024B)		DRG. NAME: BASE - EXPLODED VIEW		
DWG NO: SFMRA-S1-B		MANUFACTURING METHOD: MOLDING, MACHINING, BENDING & WELDING		
WEIGHT: 97084.88 g		SCALE: 1:75		REVISION: A
SCALE: 1:75		SHEET 4		

## BILL OF MATERIALS: TOP BODY CASING

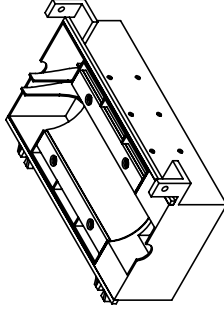

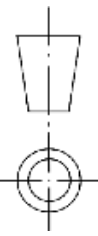

ITEM NO.	Description	PartNo	Material	QTY.
1	PRESSURE KEY	SFMRA-S2-020	Plain Carbon Steel	1
2	PRESSURE CONTROLLER	SFMRA-S2-021	Plain Carbon Steel	1
3	PRESSURE CLAMP PIN	SFMRA-S2-022	Plain Carbon Steel	1
4	PRESSURE CONTROLLER BOLT M8	N/A	Stainless Steel (ferritic)	1
5	PRESSURE CONTROLLER BOLT M8 (LONG 6MM)	N/A	Stainless Steel (ferritic)	2
6	SQUARE BAR	SFMRA-S2-023	Plain Carbon Steel	2
7	NET FRAME	SFMRA-S2-024	Plain Carbon Steel	1
8	NET	SFMRA-S2-025	Plain Carbon Steel	1
9	FLAT BAT THICKNESS 6mm	SFMRA-S2-026	Plain Carbon Steel	2
10	ROD	SFMRA-S2-027	Plain Carbon Steel	2
11	BODY TOP COVER SUPPORT SQUARE BAR (8X8)MM	SFMRA-S2-019	Plain Carbon Steel	1

UNLESS OTHERWISE SPECIFIED: STD. TOLERANCE DIMENSIONS ARE IN MILLIMETER MILLIMETER: ±0.1, ANGULAR: ±0.05° * DOES NOT APPLY TO HOLE SIZE			<b>BANGLADESH RICE RESEARCH INSTITUTE</b> SFMRA PROJECT, FMPHT DIVISION		DO NOT SCALE DRAWING
	DETAILS NAME DRAWN ENGR. SHAFER JAHAN KHAN CHK'D DR. MD. MOSHARRAF HOSSAIN APP'VD DR. AKMA SAIFUL ISLAM	SIGNATURE S J K M M H A S I	DATE 28-FEB-2024 26-MAR-2024 30-APR-2024	TITLE: BRRI MINI RICE HULLER (BRRI RM2024B) DRG. NAME: BODY CASING TOP DWG NO: SFMRA_S2.A_A	
THIRD ANGLE PROJECTION: 					FINISH: NONE FIRST ISSUED: 17-FEB-2024
MANUFACTURING METHOD: MOLDING, MACHINING, BENDING & WELDING					REVISION: A
WEIGHT: 11989.57 g SCALE: 1:20					SHEET 5

**NOTE:** DEBURR AND BREAK SHARP EDGES ALL BENDS MIN. RADIUS UNLESS SPECIFIED

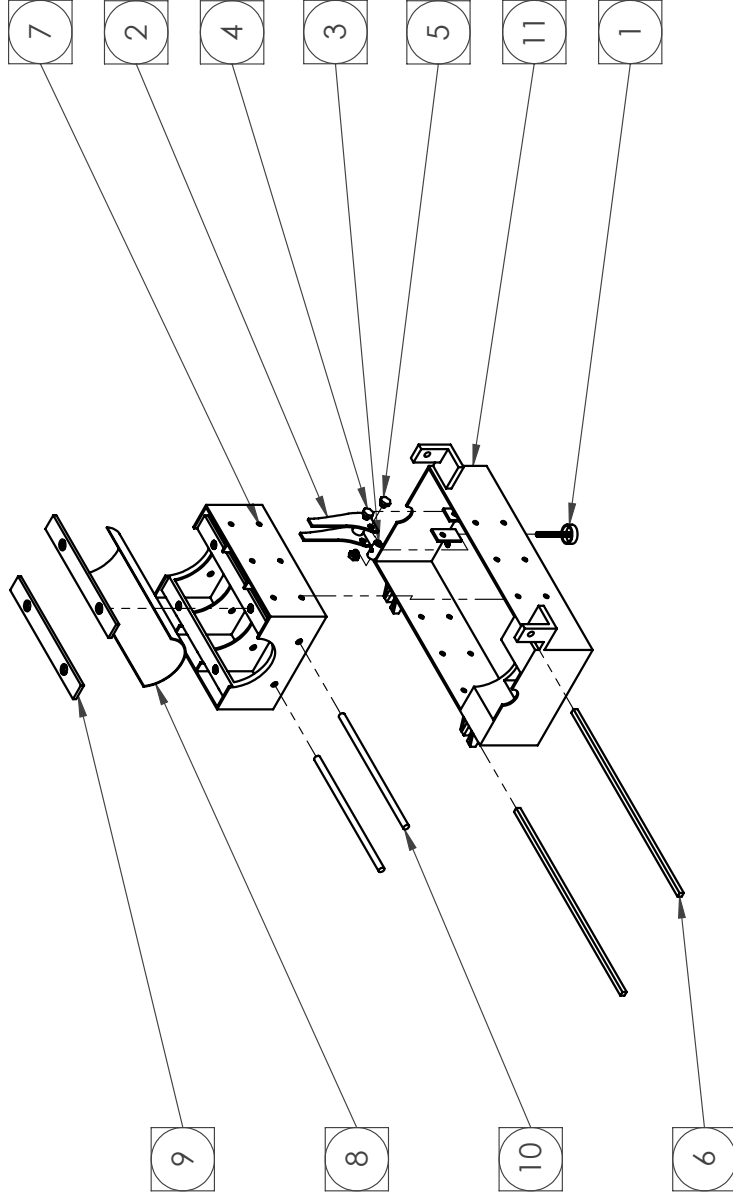
**EXPLODED VIEW - BODY CASING TOP**

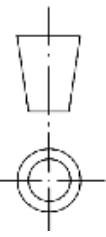

UNLESS OTHERWISE SPECIFIED: STD. TOLERANCE DIMENSIONS ARE IN MILLIMETER MILLIMETER: ±0.1, ANGULAR: ± 0.05° * DOES NOT APPLY TO HOLE SIZE				<b>BANGLADESH RICE RESEARCH INSTITUTE</b> SFMRA PROJECT, FMPHT DIVISION		DO NOT SCALE DRAWING	
DETAILS		NAME	SIGNATURE	DATE	FINISH: NONE		FIRST ISSUED: 17-FEB-2024
CHK'D	ENGR. SHAFER JAHAN KHAN	S J K		28-FEB-2024	TITLE: <b>BRI MINI RICE HULLER (BRI RM2024B)</b>		
APP'VD	DR. MD. MOSHARRAF HOSSAIN	M M H		26-MAR-2024	DRG. NAME: <b>BODY CASING TOP</b>		
THIRD ANGLE PROJECTION:		DR. AKMAJIBUL ISLAM	A S I	30-APR-2024	DWG NO: <b>SFMRA-S2.A-B</b>		
		MANUFACTURING METHOD: MOLDING, MACHINING, BENDING & WELDING					
		WEIGHT: 11989.57 g					
		SCALE: 1:20					
NOTE: DEBURR AND BREAK SHARP EDGES ALL BENDS MIN. RADIUS UNLESS SPECIFIED						SHEET 6	REVISION: A

## BILL OF MATERIALS: BODY BOTTOM CASING

ITEM NO.	Description	PartNo	MATERIAL	QTY.
1	BODY BOTTOM CASING	SFMRA-S2.B-028	Plain Carbon Steel	1
2	BODY BOTTOM CASING - 2	SFMRA-S2.B-029	Plain Carbon Steel	1
3	CASING LOCK PART - MALE	SFMRA-S2.B-031	Plain Carbon Steel	2
4	CASING LOCK PART - FEMALE	SFMRA-S2.B-032	Plain Carbon Steel	2
5	HULLER SHELL SHAFT	SFMRA-S2.B-033	ASTM A36 Steel	1
6	HULLER SHELL	SFMRA-S2.B-034	Plain Carbon Steel	1
7	HULLER SHELL - THREADED LOCK	SFMRA-S2.B-035	ASTM A36 Steel	1
8	WASHER - 1	SFMRA-S2.B-036	Plain Carbon Steel	1
9	SPRING	SFMRA-S2.B-037	Plain Carbon Steel	1
10	WASHER - 2	SFMRA-S2.B-038	Plain Carbon Steel	1
11	UCP-205	SFMRA-S2.B-038	N/A	2
12	HUSK DRANE LINE	SFMRA-S2.B-040	Plain Carbon Steel	1
13	M8 LONG BOLT FOR DOOR HINGE SYSTEM	N/A	Stainless Steel (ferritic)	2
14	POLISHER PULLEY	SFMRA-S2.B-041	Gray Cast Iron	1
15	SHAFT SLOT KEY	SFMRA-S2.B-042	Plain Carbon Steel	1
16	NET FRAME BOTTOM	SFMRA-S2.B-030	Plain Carbon Steel	1
17	POLISHER CASING FRAME PART - 1	N/A	Plain Carbon Steel	2

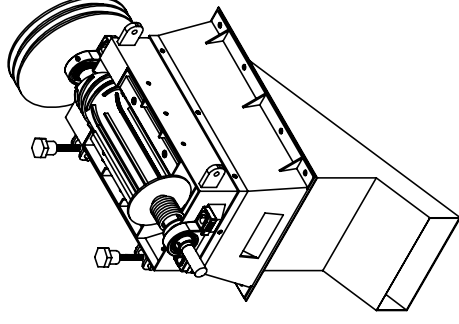

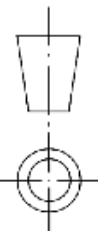
		<b>BANGLADESH RICE RESEARCH INSTITUTE</b> SFMRA PROJECT, FMPHT DIVISION		DO NOT SCALE DRAWING
UNLESS OTHERWISE SPECIFIED: STD. TOLERANCE DIMENSIONS ARE IN MILLIMETER MILLIMETER: ±0.1, ANGULAR: ± 0.05° * DOES NOT APPLY TO HOLE SIZE		SIGNATURE S J K	DATE 28-FEB-2024	FINISH: NONE
DRAWN ENGR. SHAFER JAHAN KHAN	CHKD DR. MD. MOSHARRAF HOSSAIN	APPVD DR. AKMAJIBUL ISLAM	DATE 26-MAR-2024 30-APR-2024	FIRST ISSUED: 17-FEB-2024
THIRD ANGLE PROJECTION: 		TITLE: BRRI MINI RICE HULLER (BRRI RM2024B)		
		DRG. NAME: BODY BOTTOM CASING		
		DWG NO: SFMRA-2.B-A		
		MANUFACTURING METHOD: MOLDING, MACHINING, BENDING & WELDING		
		WEIGHT: 48363.53 g		
		SCALE: 1:12		
		SHEET 7		
		REVISION: A		

**NOTE:** DEBURR AND BREAK SHARP EDGES ALL BENDS MIN. RADIUS UNLESS SPECIFIED

**EXPLODED VIEW - BODY BOTTOM CASING**

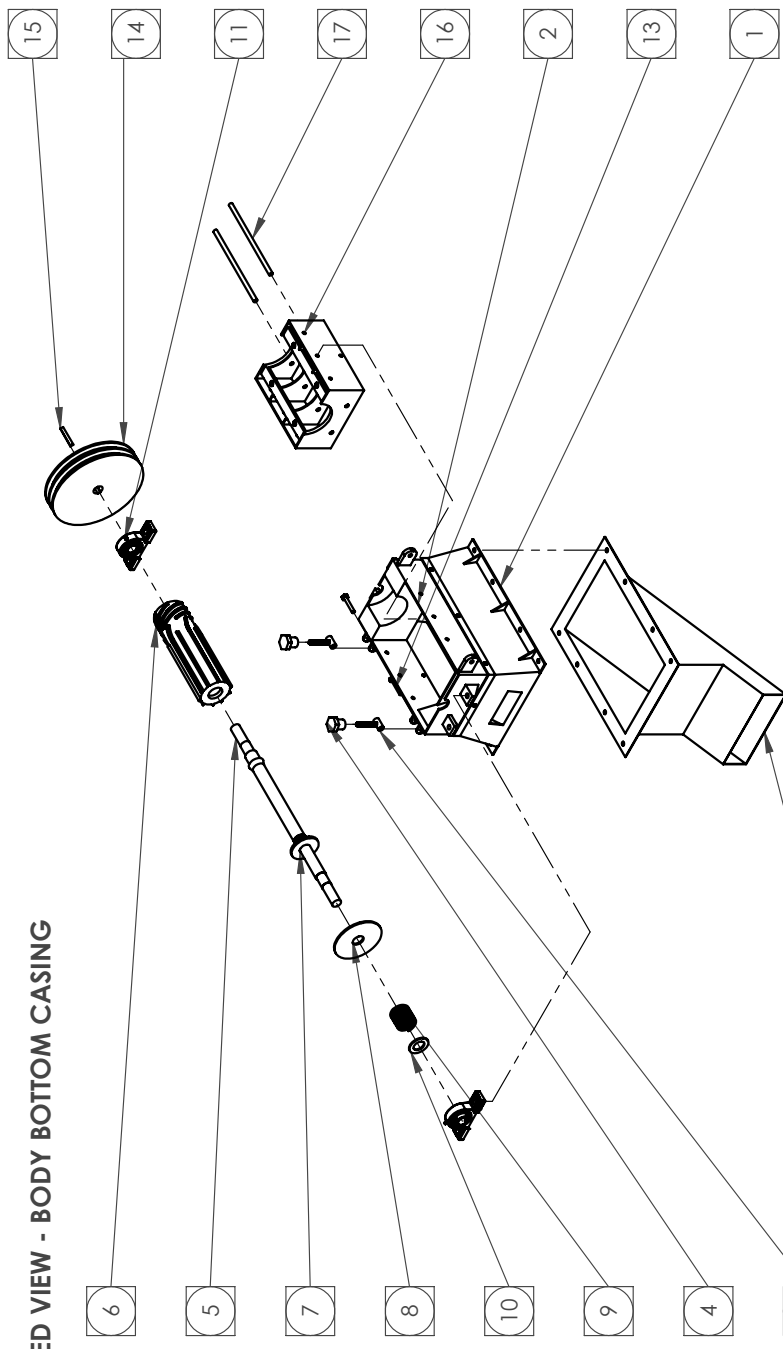

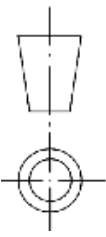

UNLESS OTHERWISE SPECIFIED: STD. TOLERANCE DIMENSIONS ARE IN MILLIMETER MILLIMETER: ±0.1, ANGULAR: ± 0.05° * DOES NOT APPLY TO HOLE SIZE		 <b>BANGLADESH RICE RESEARCH INSTITUTE</b> SFMRA PROJECT, FMPHT DIVISION		DO NOT SCALE DRAWING
DETAILS		NAME	SIGNATURE	DATE
DRAWN		ENGR. SHAFER JAHAN KHAN	S J K	28-FEB-2024
CHK'D		DR. MD. MOSHARRAF HOSSAIN	M M H	26-MAR-2024
APP'VD		DR. AKMAJIBUL ISLAM	A S I	30-APR-2024
THIRD ANGLE PROJECTION:				
TITLE: BRR I MINI RICE HULLER (BRR RM2024B)		DRG. NAME: BODY BOTTOM CASING		
DWG NO: SFMRA-52.B-B		MANUFACTURING METHOD: MOLDING, MACHINING, BENDING & WELDING		
WEIGHT: 48363.53 g		SCALE: 1:33.3		
REVISION: A		SHEET 8		

**NOTE:** DEBURR AND BREAK SHARP EDGES ALL BENDS MIN. RADIUS UNLESS SPECIFIED

## BILL OF MATERIALS: BLOWER TO CYCLONE LINE

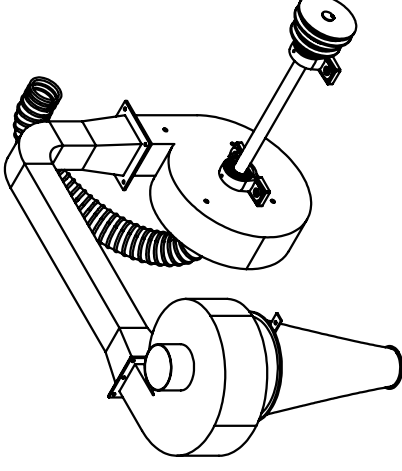
ITEM NO.	Description	PartNo	Material	QTY.
1	BLOWER	SFMRA-S3-046	Plain Carbon Steel	1
2	BLOWER SHAFT	SFMRA-S3-047	Plain Carbon Steel	1
3	HINGE - BOLT M10 - NO THREAD (QUANTITY 2)	N/A	Stainless Steel (ferritic)	1
4	BLOWER WASHER	SFMRA-S3-050	Plain Carbon Steel	1
5	UCP206	SFMRA-S3-048	Cast Alloy Steel	2
6	BOLT M6 (QUANTITY 4)	N/A	Stainless Steel (ferritic)	6
7	BLOWER FAN	SFMRA-S3-045	Plain Carbon Steel	1
8	BLOWER OUTER FLANGE	SFMRA-S3-043	Plain Carbon Steel	1
9	BLOWER PULLEY	SFMRA-S3-049	Gray Cast Iron	1
10	BLOWER UPPER HOLD PART	SFMRA-S3-051	Plain Carbon Steel	1
11	CYCLONE	SFMRA-S3-044	Plain Carbon Steel	1
12	HOSE PIPE	SFMRA-S3-052	Silicon Rubber	1

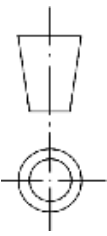

UNLESS OTHERWISE SPECIFIED: STD. TOLERANCE DIMENSIONS ARE IN MILLIMETER MILLIMETER: ±0.1, ANGULAR: ± 0.05° * DOES NOT APPLY TO HOLE SIZE				<b>BANGLADESH RICE RESEARCH INSTITUTE</b> SFMRA PROJECT, FMPHT DIVISION		DO NOT SCALE DRAWING
DETAILS	NAME	SIGNATURE	DATE			FINISH: NONE
DRAWN	ENGR. SHAFER JAHAN KHAN	S J K	28-FEB-2024			FIRST ISSUED: 17-FEB-2024
CHK'D	DR. MD. MOSHARRAF HOSSAIN	M M H	26-MAR-2024			
APP'VD	DR. AKM SAIFUL ISLAM	A S I	30-APR-2024			
THIRD ANGLE PROJECTION:						
TITLE: BRRI MINI RICE HULLER (BRRI RM2024B) DRG. NAME: BLOWER TO CYCLONE LINE DWG NO: SFMRA-S3-A						
MANUFACTURING METHOD: MOLDING, MACHINING, BENDING & WELDING						
WEIGHT: 33151.64 g				SCALE: 1:15		REVISION: A
				SHEET 9		A

**NOTE:** DEBURR AND BREAK SHARP EDGES ALL BENDS MIN. RADIUS UNLESS SPECIFIED

**EXPLODED VIEW - BLOWER TO CYCLONE LINE**

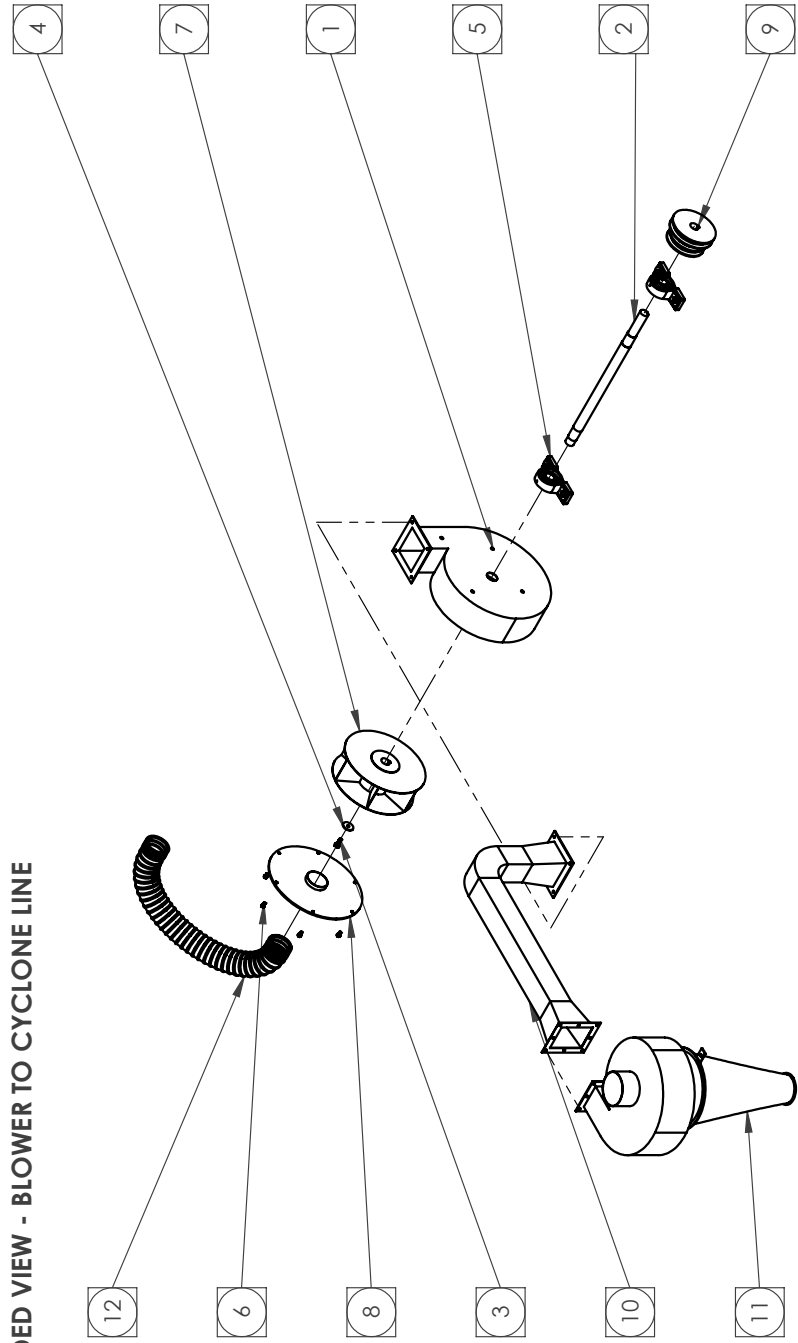

UNLESS OTHERWISE SPECIFIED: STD. TOLERANCE DIMENSIONS ARE IN MILLIMETER MILLIMETER: ±0.1, ANGULAR: ± 0.05° * DOES NOT APPLY TO HOLE SIZE			BANGLADESH RICE RESEARCH INSTITUTE SFMRA PROJECT, FMPHT DIVISION		DO NOT SCALE DRAWING
	DETAILS NAME SIGNATURE DATE		DRAWN ENGR. SHAFER JAHAN KHAN S J K 28-FEB-2024		FINISH: NONE
CHK'D DR. MD. MOSHARRAF HOSSAIN M M H 26-MAR-2024		APP'VD DR. AKMA SAIFUL ISLAM A S I 30-APR-2024		FIRST ISSUED: 17-FEB-2024	
TITLE: BRRI MINI RICE HULLER (BRRI RM2024B)					
DRG. NAME: BLOWER TO CYCLONE LINE					
DWG NO: SFMRA-53-B					
MANUFACTURING METHOD: MOLDING, MACHINING, BENDING & WELDING					
WEIGHT: 33151.64 g				A4	
SCALE: 1:20				SHEET 10	
REVISION:				A	

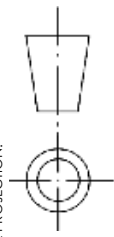

**NOTE:** DEBURR AND BREAK SHARP EDGES ALL BENDS MIN. RADIUS UNLESS SPECIFIED

### BILL OF MATERIALS: TENSION

ITEM NO.	Description	PartNo	Material	QTY.
1	TENSION SHAFT - 2	SFMRA-S4-053	Plain Carbon Steel	1
2	PULLEY HOLDER	SFMRA-S4-054	Plain Carbon Steel	1
3	WASHER	SFMRA-S4-055	Plain Carbon Steel	1
4	TENSION SHAFT - PULLEY TIGHT BOLT	N/A	Plain Carbon Steel	1
5	6205 RS BEARING - USED IN TENSION	SFMRA-S4-057	N/A	2
6	TENSION BOLT M8	N/A	Stainless Steel (ferritic)	2
7	TENSION PULLEY	SFMRA-S4-056	Gray Cast Iron	1

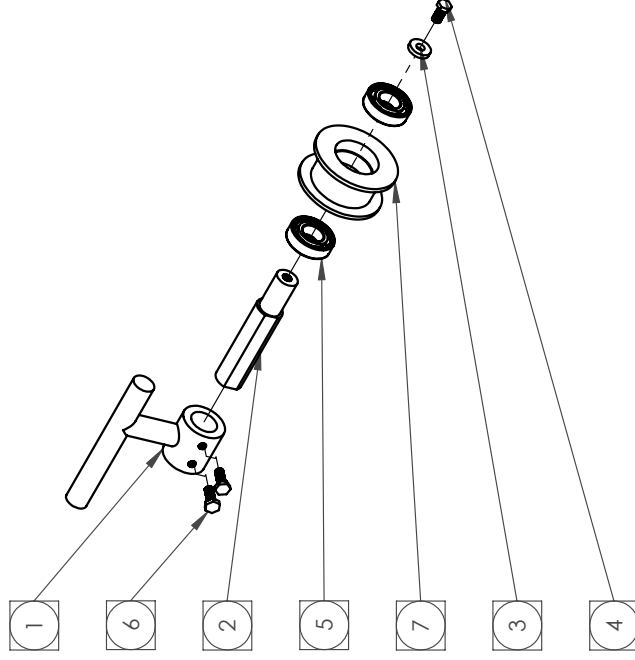
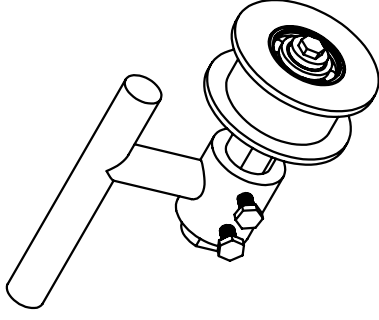

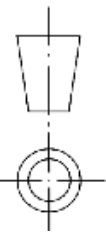

UNLESS OTHERWISE SPECIFIED: STD. TOLERANCE DIMENSIONS ARE IN MILLIMETER MILLIMETER: ±0.1, ANGULAR: ± 0.05° * DOES NOT APPLY TO HOLE SIZE		 <b>BANGLADESH RICE RESEARCH INSTITUTE</b> SFMRA PROJECT, FMPHT DIVISION		DO NOT SCALE DRAWING
DETAILS		SIGNATURE	DATE	FINISH: NONE
DRAWN	ENGR. SHAFER JAHAN KHAN	S J K	28-FEB-2024	FIRST ISSUED: 17-FEB-2024
CHK'D	DR. MD. MOSHARRAF HOSSAIN	M M H	26-MAR-2024	
APP'VD	DR. AKMA SAIFUL ISLAM	A S I	30-APR-2024	
THIRD ANGLE PROJECTION:				
TITLE: BRR I MINI RICE HULLER (BRR I RM2024B)				
DRG. NAME: TENSION				
DWG NO: SFMRA-S4				
MANUFACTURING METHOD: MOLDING, MACHINING, BENDING & WELDING				
WEIGHT: 3186.01 g			A4	
SCALE: 1:10			REVISION: A	
SHEET 11				

**NOTE:** DEBURR AND BREAK SHARP EDGES ALL BENDS MIN. RADIUS UNLESS SPECIFIED

**BILL OF MATERIALS: HOPPER**

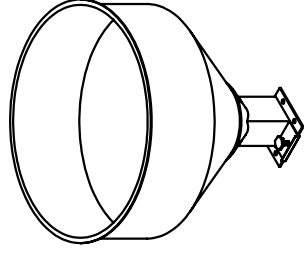
ITEM NO.	Description	PartNo	Material	QTY.
1	HOPPER-BASE	SFMRA-S5-076	Plain Carbon Steel	1
2	HOPPER	SFMRA-S5-077	Plain Carbon Steel	1
3	HOPPER - PADDY SUPPEY CONTROLLER	SFMRA-S5-078	Plain Carbon Steel	1
4	HOPPER THREAD KEY - M8	SFMRA-S5-079	Plain Carbon Steel	1

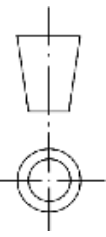

UNLESS OTHERWISE SPECIFIED: STD. TOLERANCE DIMENSIONS ARE IN MILLIMETER MILLIMETER: ±0.1, ANGULAR: ± 0.05° * DOES NOT APPLY TO HOLE SIZE			<b>BANGLADESH RICE RESEARCH INSTITUTE</b> SFMRA PROJECT, FMPHT DIVISION		DO NOT SCALE DRAWING
	DETAILS NAME ENGR. SHAFER JAHAN KHAN	SIGNATURE S J K	DATE 28-FEB-2024	TITLE: <b>BRR MINI RICE HULLER (BRR RM2024B)</b>	
CHK'D DR. MD. MOSHARRAF HOSSAIN	M M H	26-MAR-2024	DRG. NAME: HOPPER		FIRST ISSUED: 17-FEB-2024
APP'VD DR. AKMAJIBUL ISLAM	A S I	30-APR-2024	DWG NO: SFMRA-S5-A		
THIRD ANGLE PROJECTION: 			MANUFACTURING METHOD: MOLDING, MACHINING, BENDING & WELDING		
NOTE: DEBURR AND BREAK SHARP EDGES ALL BENDS MIN. RADIUS UNLESS SPECIFIED			WEIGHT: 6462.70 g SCALE: 1:20		REVISION: A
			SHEET 12		A

**EXPLODED VIEW - HOPPER**

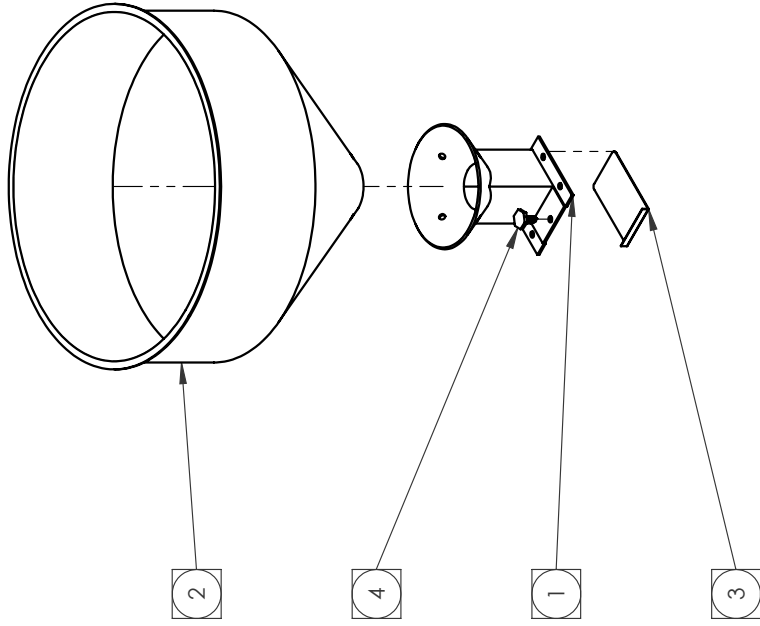

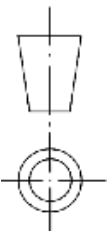
UNLESS OTHERWISE SPECIFIED: STD. TOLERANCE DIMENSIONS ARE IN MILLIMETER MILLIMETER: ±0.1, ANGULAR: ± 0.05° * DOES NOT APPLY TO HOLE SIZE				<b>BANGLADESH RICE RESEARCH INSTITUTE</b> SFMRA PROJECT, FMPHT DIVISION		DO NOT SCALE DRAWING	
DETAILS	NAME	SIGNATURE	DATE	<b>TITLE: BRRI MINI RICE HULLER (BRRI RM2024B)</b>		FINISH: NONE	
DRAWN	ENGR. SHAFER JAHAN KHAN	S J K	28-FEB-2024	DRG. NAME: HOPPER		FIRST ISSUED: 17-FEB-2024	
CHK'D	DR. MD. MOSHARRAF HOSSAIN	M M H	26-MAR-2024	DWG NO: SFMRA-SS-B			
APP'VD	DR. AKMAJIBUL ISLAM	A S I	30-APR-2024	MANUFACTURING METHOD: MOLDING, MACHINING, BENDING & WELDING			
THIRD ANGLE PROJECTION:							
NOTE: DEBURR AND BREAK SHARP EDGES ALL BENDS MIN. RADIUS UNLESS SPECIFIED				SCALE: 1:20		SHEET 13	
				WEIGHT: 6462.70 g		REVISION:	
				A4		A	

**BILL OF MATERIALS: SIZE GRADER**

ITEM NO.	Description	PartNo	Material	QTY.
1	GRADER OUTER CASING	SFMRA-S6-080	Plain Carbon Steel	1
2	GRADER - BROKEN RICE LINE	SFMRA-S6-081	Plain Carbon Steel	1
3	GRADER FRAME - 1	SFMRA-S6-082	Plain Carbon Steel	1
4	GRADER NET	SFMRA-S6-083	Plain Carbon Steel	1
5	GRADER NET FRAME - 1	SFMRA-S6-084	Plain Carbon Steel	1
6	GRADER HOLDING PART	RM2024A-S6-085	Plain Carbon Steel	1

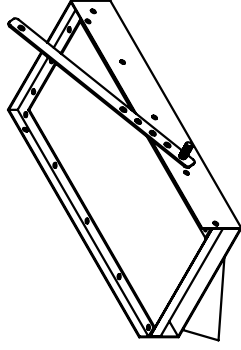

UNLESS OTHERWISE SPECIFIED: STD. TOLERANCE DIMENSIONS ARE IN MILLIMETER MILLIMETER: ±0.1, ANGULAR: ± 0.05° * DOES NOT APPLY TO HOLE SIZE		<b>BANGLADESH RICE RESEARCH INSTITUTE</b> SFMRA PROJECT, FMPHT DIVISION		DO NOT SCALE DRAWING
				FINISH: NONE
				FIRST ISSUED: 17-FEB-2024
		TITLE: BRRI MINI RICE HULLER (BRRI RM2024B)		
		DRG. NAME: SIZE GRADER		
		DWG NO: SFMRA-S6-A		
		MANUFACTURING METHOD: MOLDING, MACHINING, BENDING & WELDING		
		WEIGHT: 5162.11 g		A4
		SCALE: 1:20		REVISION: A
		SHEET 14		



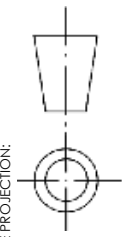

DETAILS	NAME	SIGNATURE	DATE
DRAWN	ENGR. SHAFER JAHAN KHAN	S J K	28-FEB-2024
CHK'D	DR. MD. MOSHARRAF HOSSAIN	M M H	26-MAR-2024
APP'VD	DR. AKMA SAIFUL ISLAM	A S I	30-APR-2024

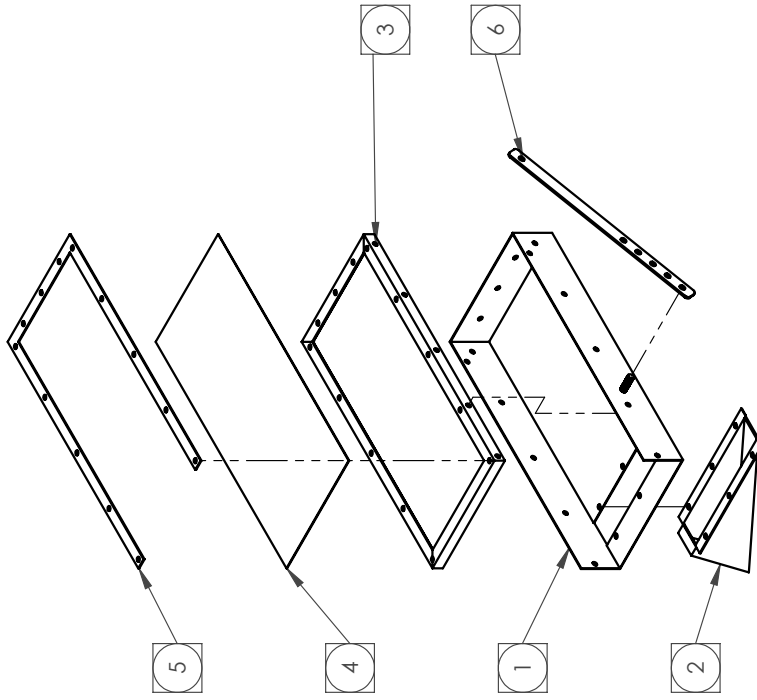

**NOTE:** DEBURR AND BREAK SHARP EDGES ALL BENDS MIN. RADIUS UNLESS SPECIFIED

**EXPLODED VIEW - SIZE GRADER**

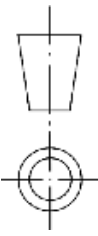

UNLESS OTHERWISE SPECIFIED: STD. TOLERANCE DIMENSIONS ARE IN MILLIMETER MILLIMETER: ±0.1, ANGULAR: ± 0.05° * DOES NOT APPLY TO HOLE SIZE				BANGLADESH RICE RESEARCH INSTITUTE SFMRA PROJECT, FMPHT DIVISION		DO NOT SCALE DRAWING	
DETAILS NAME SIGNATURE DATE		DRAWN ENGR. SHAFER JAHAN KHAN S J K 28-FEB-2024		TITLE: BRRI MINI RICE HULLER (BRRI RM2024B)		FINISH: NONE	
CHK'D DR. MD. MOSHARRAF HOSSAIN M M H 26-MAR-2024		APP'VD DR. AKMAJIBUL ISLAM A S I 30-APR-2024		DRG. NAME: SIZE GRADER		FIRST ISSUED: 17-FEB-2024	
THIRD ANGLE PROJECTION:				DWG NO: SFMRA-56-B		SCALE: 1:20	
NOTE: DEBURR AND BREAK SHARP EDGES ALL BENDS MIN. RADIUS UNLESS SPECIFIED		MANUFACTURING METHOD: MOLDING, MACHINING, BENDING & WELDING		WEIGHT: 5162.11 g		REVISION: A	
				SHEET 15		A	

**BILL OF MATERIALS: CLEANING CHAMBER**

ITEM NO.	Description	PartNo	Material	QTY.
1	POLISHER TO OUIPUT SIDE PART-1	SFMRA-S7-087	Plain Carbon Steel	1
2	POLISHER TO OUIPUT SIDE PART-2	SFMRA-S7-086	Plain Carbon Steel	1

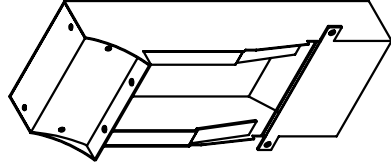
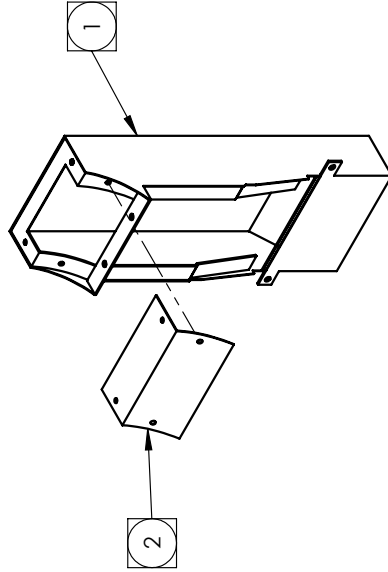

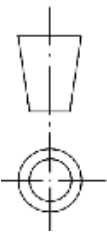
UNLESS OTHERWISE SPECIFIED: STD. TOLERANCE DIMENSIONS ARE IN MILLIMETER MILLIMETER: ±0.1, ANGULAR: ± 0.05° * DOES NOT APPLY TO HOLE SIZE			<b>BANGLADESH RICE RESEARCH INSTITUTE</b> SFMRA PROJECT, FMPHT DIVISION		DO NOT SCALE DRAWING
	DETAILS NAME ENGR. SHAFER JAHAN KHAN	SIGNATURE S J K	DATE 28-FEB-2024	TITLE: <b>BRI MINI RICE HULLER (BRI RM2024B)</b>	
CHK'D DR. MD. MOSHARRAF HOSSAIN	M M H	26-MAR-2024	DRG. NAME: <b>CLEANING CHAMBER</b>		FIRST ISSUED: 17-FEB-2024
APP'VD DR. AKMA SAIFUL ISLAM	A S I	30-APR-2024	DWG NO: SFMRA-S7		
THIRD ANGLE PROJECTION: 			MANUFACTURING METHOD: MOLDING, MACHINING, BENDING & WELDING		
			WEIGHT: 5033.39 g		REVISION: A
			SCALE: 1:10		SHEET 16

**NOTE:** DEBURR AND BREAK SHARP EDGES ALL BENDS MIN. RADIUS UNLESS SPECIFIED

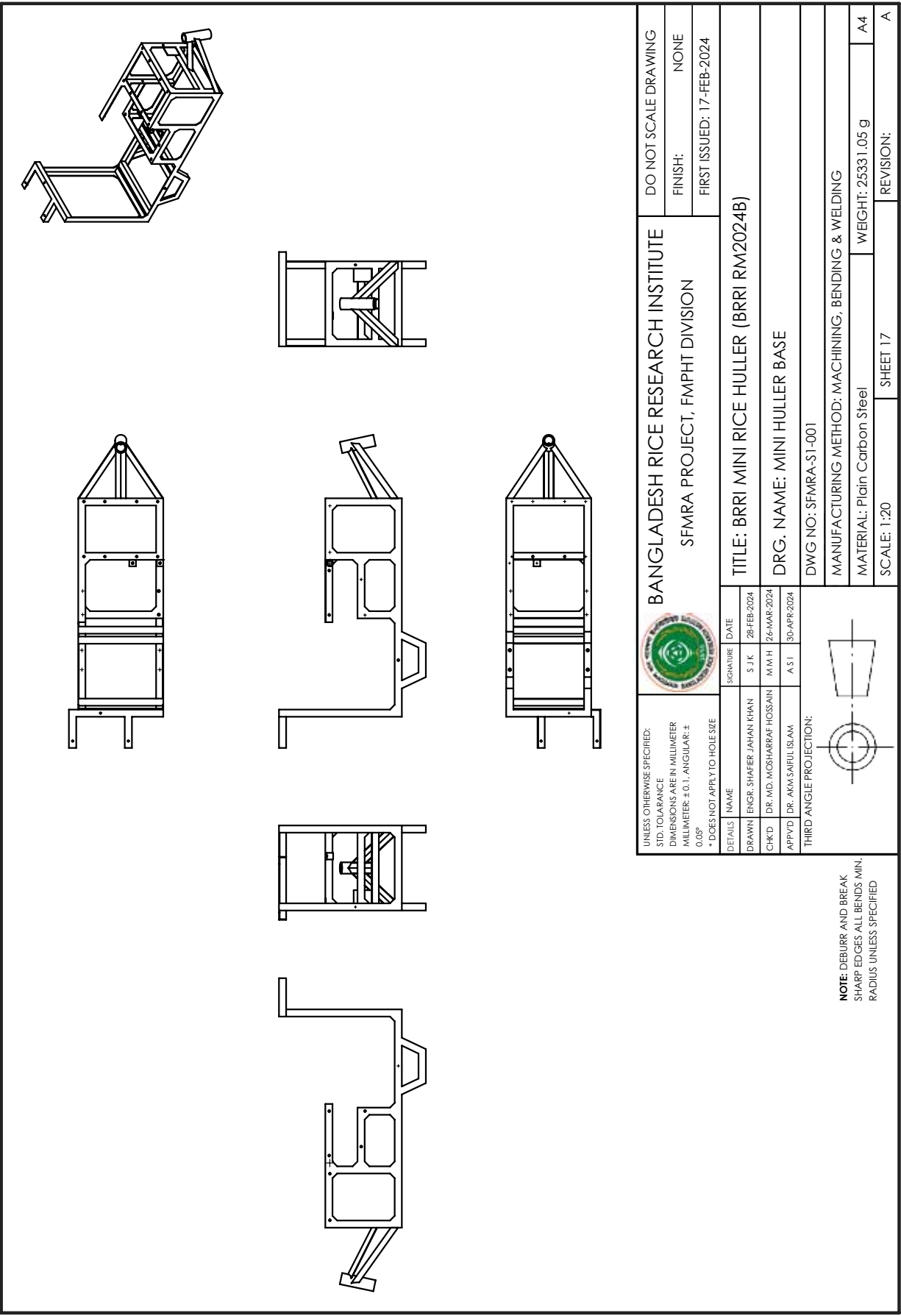

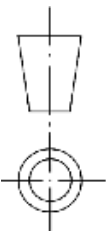
UNLESS OTHERWISE SPECIFIED: STD. TOLERANCE DIMENSIONS ARE IN MILLIMETER MILLIMETER: ±0.1, ANGULAR: ± 0.05° * DOES NOT APPLY TO HOLE SIZE				<b>BANGLADESH RICE RESEARCH INSTITUTE</b> SFMRA PROJECT, FMPHT DIVISION		DO NOT SCALE DRAWING	
DETAILS	NAME	SIGNATURE	DATE			FINISH:	NONE
DRAWN	ENGR. SHAFER JAHAN KHAN	S J K	28-FEB-2024			FIRST ISSUED:	17-FEB-2024
CHK'D	DR. MD. MOSHARRAF HOSSAIN	M M H	26-MAR-2024			TITLE: <b>BRI MINI RICE HULLER (BRI RM2024B)</b>	
APP'VD	DR. AKMA SAIFUL ISLAM	A S I	30-APR-2024			DRG. NAME: <b>MINI HULLER BASE</b>	
THIRD ANGLE PROJECTION:						DWG NO: <b>SFMRA-S1-001</b>	
						MANUFACTURING METHOD: <b>MACHINING, BENDING &amp; WELDING</b>	
						MATERIAL: <b>Plain Carbon Steel</b>	
						SCALE: <b>1:20</b>	
						SHEET <b>17</b>	
						WEIGHT: <b>25331.05 g</b>	
						REVISION: <b>A</b>	

**NOTE:** DEBURR AND BREAK SHARP EDGES ALL BENDS MIN. RADIUS UNLESS SPECIFIED

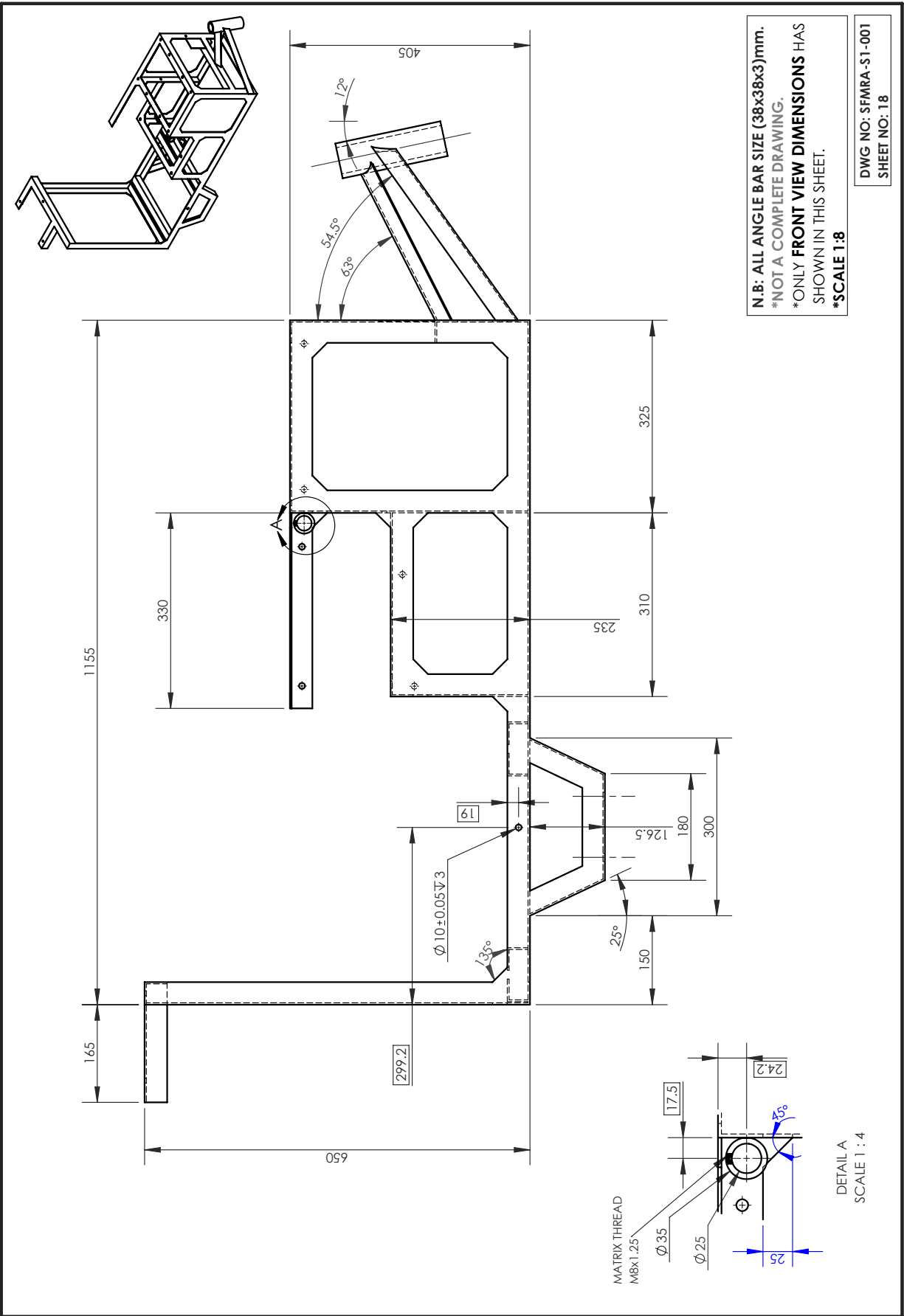

DETAIL A  
SCALE 1 : 4

\*NOT A COMPLETE DRAWING.  
 \*ONLY RIGHT & REAR VIEW DIMENSIONS  
 HAS SHOWN IN THIS SHEET.  
 \*SCALE 1:12

\*  $4 \times \phi 10 \pm 0.04 \nabla 3$  HOLES FOR BLOWER. THE BLOWER WILL  
 FIT HERE. NUT-M8 (x4) WILL BE WELDED WITH THE 4 HOLES.  
 SO THAT, M8 BOLTS CAN IN AND OUT TO PLACE/REMOVE  
 BLOWER BODY.

\*  $4 \times \phi 14 \pm 0.05 \nabla 3$  HOLES FOR THE WHEEL AXLE. THE  
 WHEEL AXLE WILL FIT HERE.

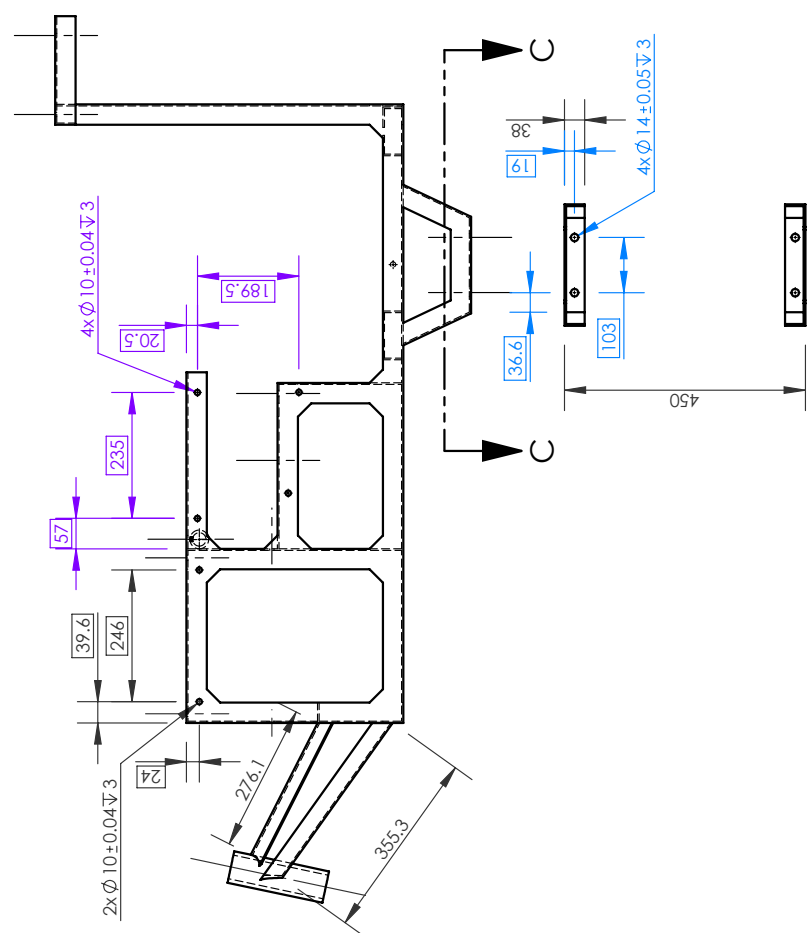
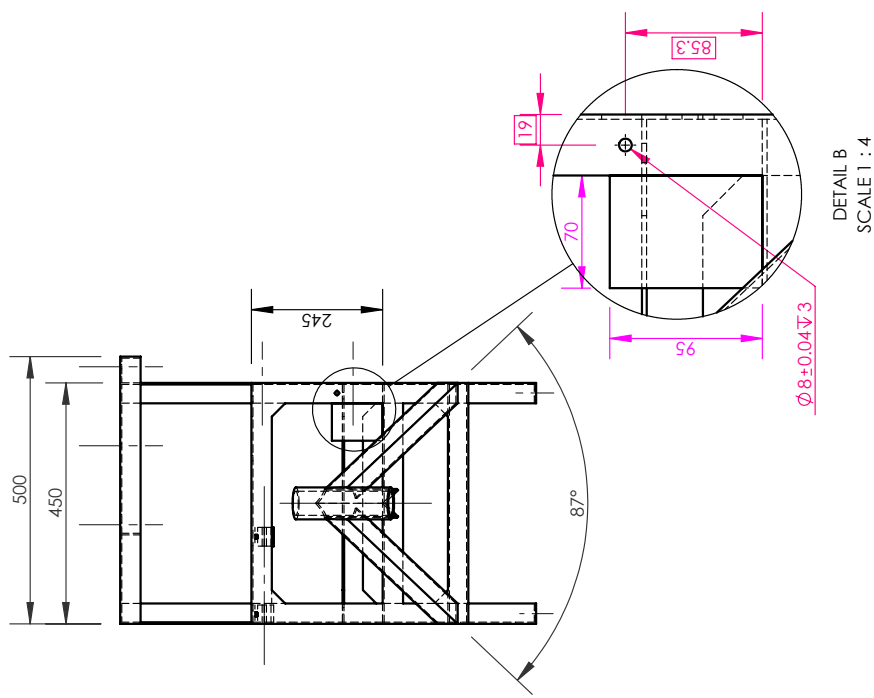
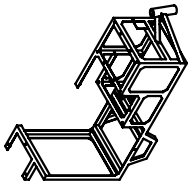

DETAIL B  
 SCALE 1 : 4  
 \*  $195 \times 70 \times 1.5$  mm AREA FOR THE ELECTRIC  
 SWITCHBOARD.  
 \*  $\phi 8 \pm 0.04 \nabla 3$  HOLE FOR SIZE GRADER.

SECTION C-C  
 SCALE 1 : 12

DRAWING NUMBER: SFMRA-S1-001  
 SHEET NO: 19

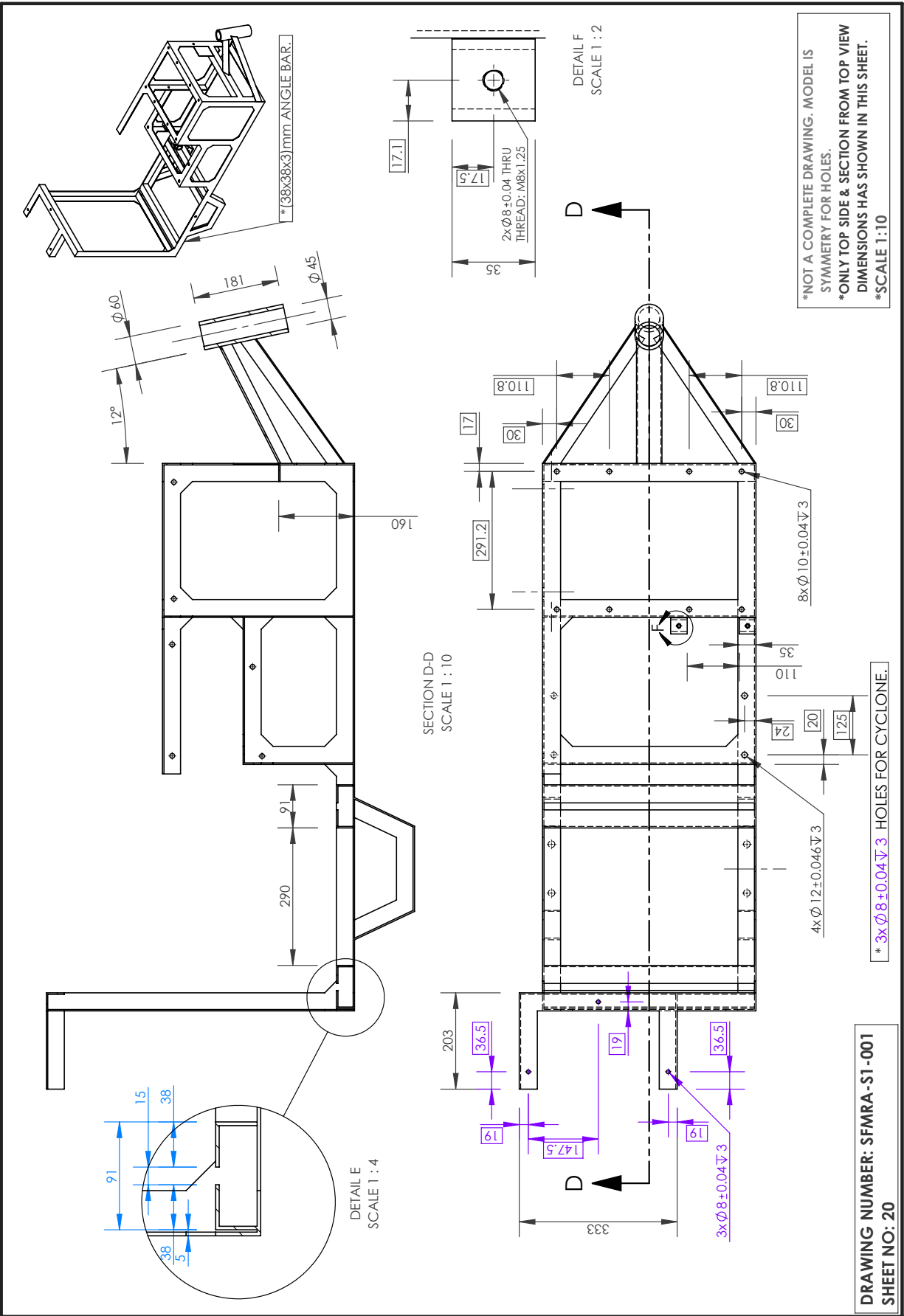

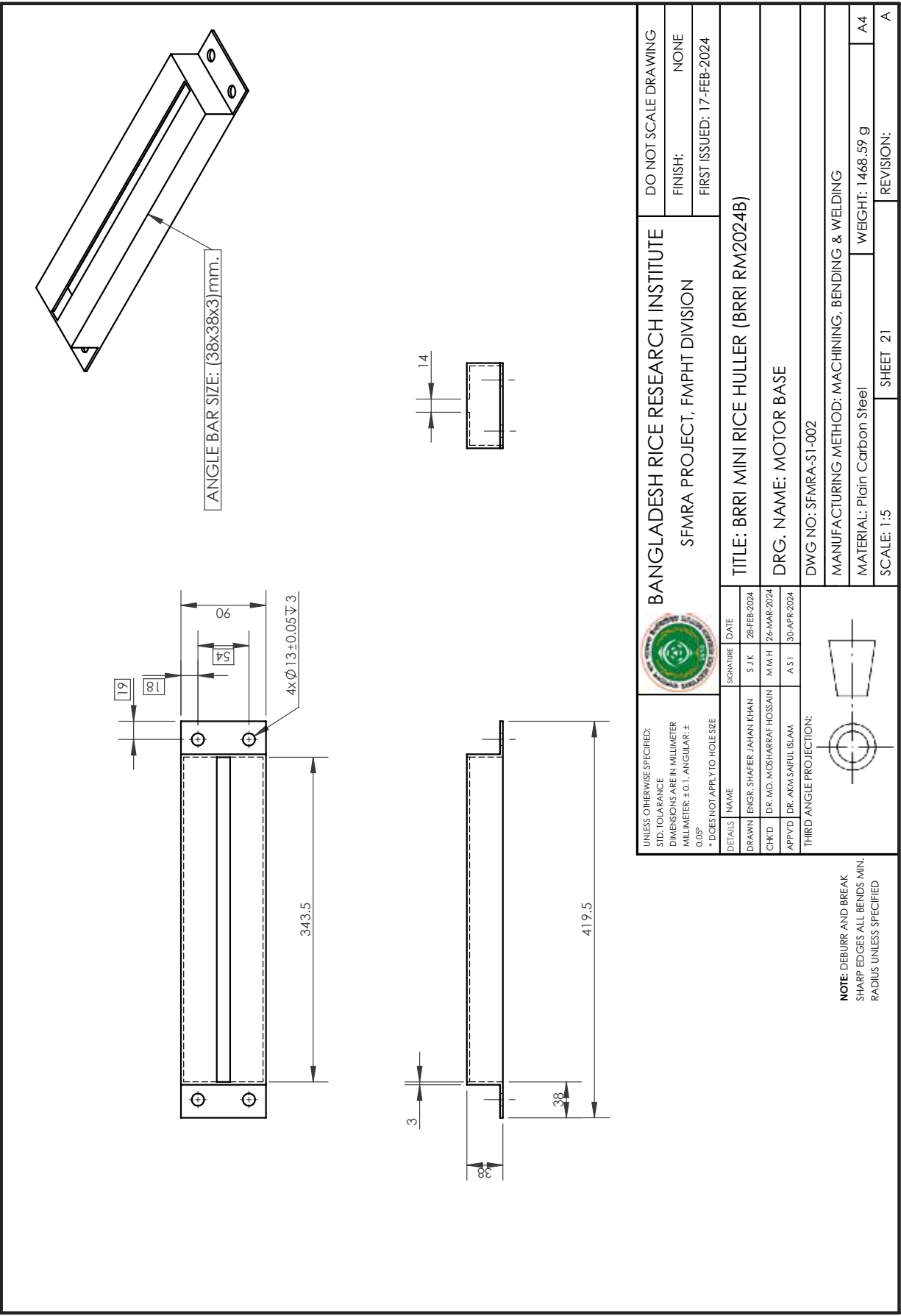

ANGLE BAR SIZE: 38x38x3 mm.

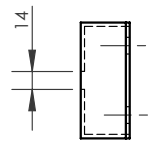
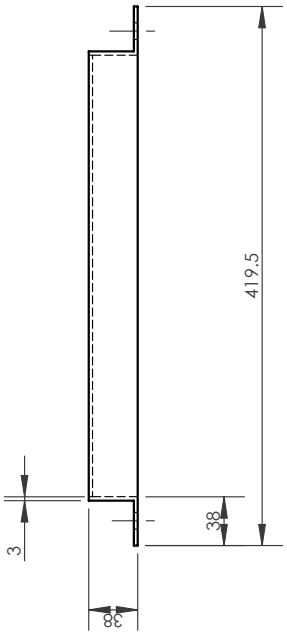
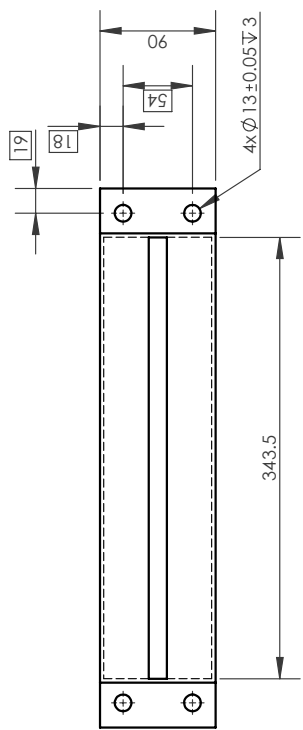

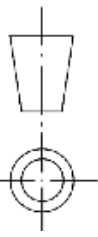
UNLESS OTHERWISE SPECIFIED: STD. TOLERANCE DIMENSIONS ARE IN MILLIMETER MILLIMETER: ±0.1, ANGULAR: ± 0.05° * DOES NOT APPLY TO HOLE SIZE				<b>BANGLADESH RICE RESEARCH INSTITUTE</b> SFMRA PROJECT, FMPHT DIVISION		DO NOT SCALE DRAWING	
DETAILS	NAME	SIGNATURE	DATE	TITLE: BRRI MINI RICE HULLER (BRRI RM2024B)		FINISH:	NONE
DRAWN	ENGR. SHAFIEE JAHAN KHAN	S J K	28-FEB-2024	DRG. NAME: MOTOR BASE		FIRST ISSUED:	17-FEB-2024
CHK'D	DR. MD. MOHARRAF HOSSAIN	M M H	26-MAR-2024	DWG NO: SFMRA-S1-002		MANUFACTURING METHOD: MACHINING, BENDING & WELDING	
APP'VD	DR. AKMAJILU ISLAM	A S I	30-APR-2024	THIRD ANGLE PROJECTION:		MATERIAL: Plain Carbon Steel	
						WEIGHT: 1468.59 g	
				<b>NOTE: DEBURR AND BREAK SHARP EDGES ALL BENDS MIN. RADIUS UNLESS SPECIFIED</b>		SCALE: 1:5	
				SHEET 21		REVISION: A	

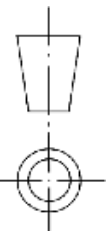

MOTOR HP: 7.5HP  
 SPEED: 1450 RPM  
 SINGLE PHASE MOTOR

UNLESS OTHERWISE SPECIFIED: STD. TOLERANCE DIMENSIONS ARE IN MILLIMETER MILLIMETER: ±0.1, ANGULAR: ± 0.05° * DOES NOT APPLY TO HOLE SIZE				BANGLADESH RICE RESEARCH INSTITUTE SFMRA PROJECT, FMPHT DIVISION		DO NOT SCALE DRAWING	
DETAILS	NAME	SIGNATURE	DATE				
DRAWN	ENGR. SHAFER JAHAN KHAN	S J K	28-FEB-2024				
CHK'D	DR. MD. MOSHARRAF HOSSAIN	M M H	26-MAR-2024	TITLE: BRR I MINI RICE HULLER (BRR RM2024B)			
APP'VD	DR. AKMAJIBUL ISLAM	A S I	30-APR-2024	DRG. NAME: MOTOR			
THIRD ANGLE PROJECTION:							
				DWG NO: SFMRA-S1-003			
				OUTSOURCING: VENDOR			
				MATERIAL: N/A		WEIGHT: N/A	
				SCALE: 1:10		SHEET 22	
						REVISION: A	

**NOTE:** DEBURR AND BREAK SHARP EDGES ALL BENDS MIN. RADIUS UNLESS SPECIFIED

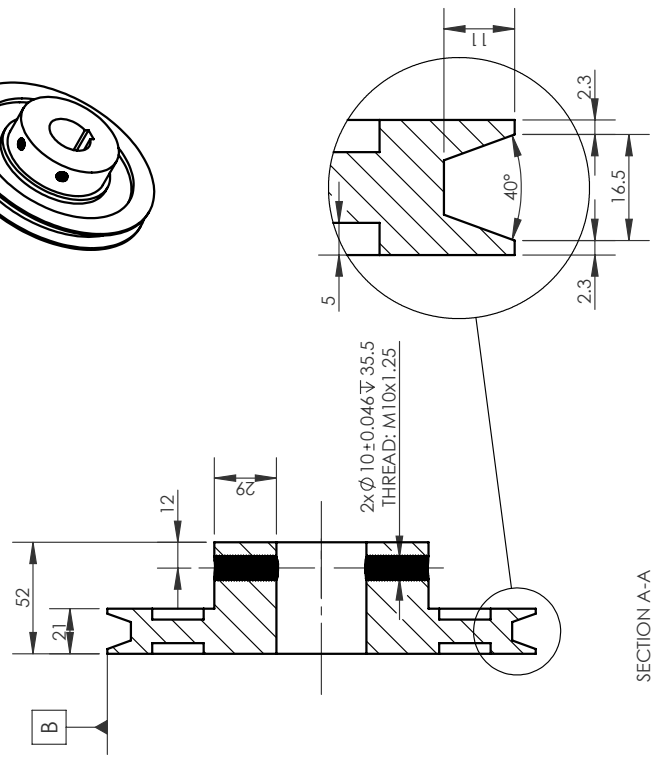
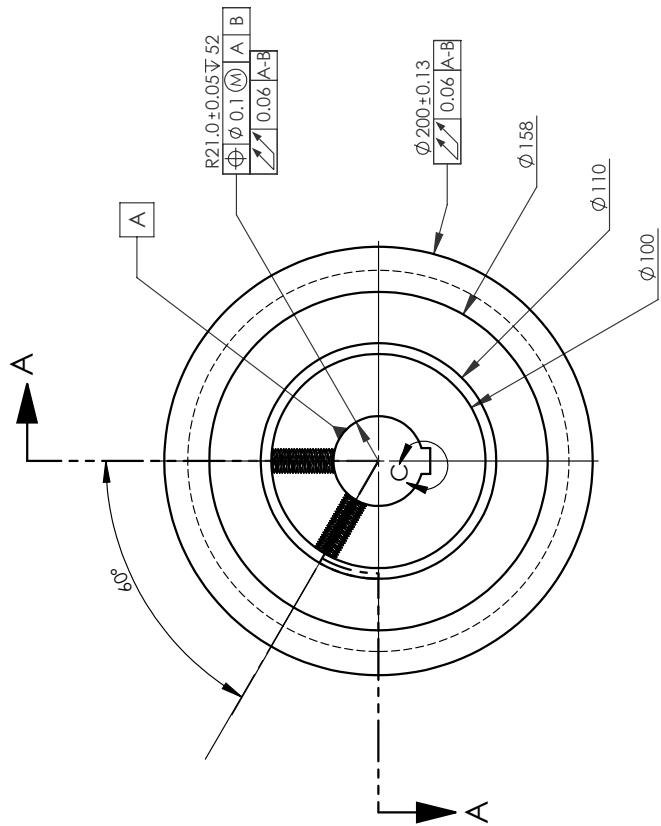

SECTION A-A  
SCALE 1 : 3

DETAIL B  
SCALE 1 : 1

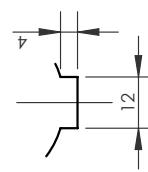

DETAIL C  
SCALE 2 : 3



**BANGLADESH RICE RESEARCH INSTITUTE**  
SFMRA PROJECT, FMPHT DIVISION

**TITLE: BRRI MINI RICE HULLER (BRRI RM2024B)**

**DRG. NAME: MOTOR PULLEY**

**DWG NO: SFMRA-S1-004**

**MANUFACTURING METHOD: MACHINING, BENDING & WELDING**

**MATERIAL: Gray Cast Iron**

**WEIGHT: 4613.31 g**

**SCALE: 1:5**

**SHEET 23**

**REVISION: A**

UNLESS OTHERWISE SPECIFIED:  
STD. TOLERANCE  
DIMENSIONS ARE IN MILLIMETER  
MILLIMETER: ±0.1, ANGULAR: ±  
0.05°  
\* DOES NOT APPLY TO HOLE SIZE

DETAILS	NAME	SIGNATURE	DATE
DRAWN	ENGR. SHAFER JAHAN KHAN	S J K	28-FEB-2024
CHK'D	DR. MD. MOSHARRAF HOSSAIN	M W H	26-MAR-2024
APP'D	DR. AKMA SAIFUL ISLAM	A S I	30-APR-2024

THIRD ANGLE PROJECTION:

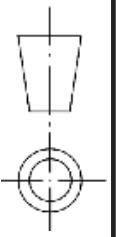



**NOTE: DEBURR AND BREAK SHARP EDGES ALL BENDS MIN. RADIUS UNLESS SPECIFIED**

**DO NOT SCALE DRAWING**

**FINISH: NONE**

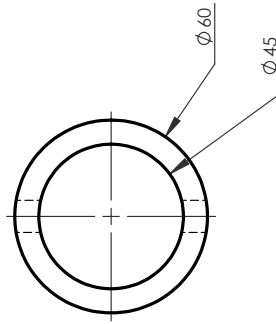
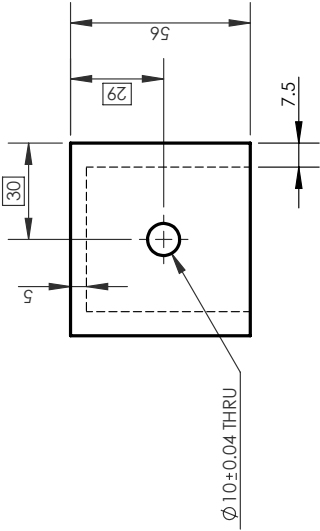
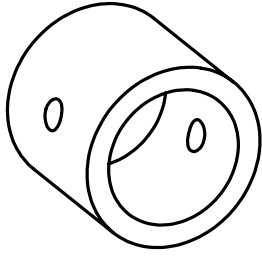
**FIRST ISSUED: 17-FEB-2024**

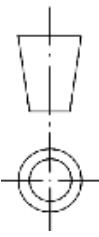

UNLESS OTHERWISE SPECIFIED: STD. TOLERANCE DIMENSIONS ARE IN MILLIMETER MILLIMETER: $\pm 0.1$ , ANGULAR: $\pm 0.05^\circ$ * DOES NOT APPLY TO HOLE SIZE		 <b>BANGLADESH RICE RESEARCH INSTITUTE</b> SFMRA PROJECT, FMPHT DIVISION		DO NOT SCALE DRAWING
DETAILS		NAME	SIGNATURE	DATE
DRAWN	ENGR. SHAFIEE JAHAN KHAN	S J K		28-FEB-2024
CHK'D	DR. MD. MOSHARRAF HOSSAIN	M M H		26-MAR-2024
APP'VD	DR. AKMA SAIFUL ISLAM	A S I		30-APR-2024
THIRD ANGLE PROJECTION:				
TITLE: <b>BRR I MINI RICE HULLER (BRR I RM2024B)</b> DRG. NAME: <b>BASE WHEEL PART - 1</b> DWG NO: <b>SFMRA-S1-005</b> MANUFACTURING METHOD: <b>MACHINING, BENDING &amp; WELDING</b> MATERIAL: <b>Plain Carbon Steel</b> SCALE: <b>1:2</b> WEIGHT: <b>593.12 g</b> SHEET <b>24</b>				
FINISH: <b>NONE</b>				REVISION: <b>A</b>
FIRST ISSUED: <b>17-FEB-2024</b>				

**NOTE:** DEBURR AND BREAK SHARP EDGES ALL BENDS MIN. RADIUS UNLESS SPECIFIED

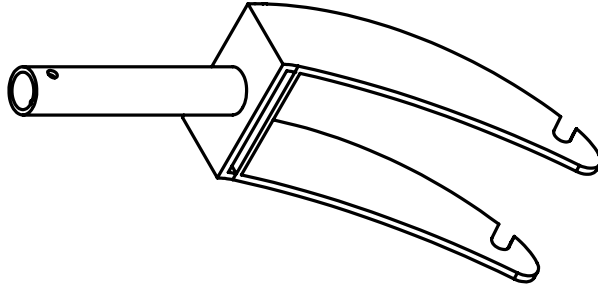

NAME: FRONT WHEEL CARRYING FRAME  
 MADE: LOCALLY MADE  
 WHEEL DIA: 400mm  
 THICKNESS: 8mm  
 UPPER PIPE DIA: 36mm  
 \*(35-40)mm DIA IS ACCEPTED.

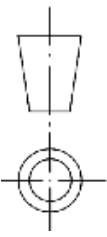
UNLESS OTHERWISE SPECIFIED: STD. TOLERANCE DIMENSIONS ARE IN MILLIMETER MILLIMETER: ±0.1, ANGULAR: ± 0.05° * DOES NOT APPLY TO HOLE SIZE				<b>BANGLADESH RICE RESEARCH INSTITUTE</b> SFMRA PROJECT, FMPHT DIVISION		DO NOT SCALE DRAWING	
DETAILS		NAME	SIGNATURE	DATE	FINISH: NONE		
DRAWN		ENGR. SHAFIEE JAHAN KHAN	S J K	28-FEB-2024	FIRST ISSUED: 17-FEB-2024		
CHK'D		DR. MD. MOSHARRAF HOSAIN	M M H	26-MAR-2024	TITLE: BRRI MINI RICE HULLER (BRRI RM2024B)		
APP'VD		DR. AKMASAIFUL ISLAM	A S I	30-APR-2024	DRG. NAME: FRONT WHEEL CASING		
THIRD ANGLE PROJECTION:				DWG NO: SFMRA-S1-006			REVISION: A
NOTE: DEBURR AND BREAK SHARP EDGES ALL BENDS MIN. RADIUS UNLESS SPECIFIED		OUTSOURCING: VENDOR		MATERIAL: Plain Carbon Steel			WEIGHT: 5691.68 g
		SCALE: 1:10		SHEET 25			A4

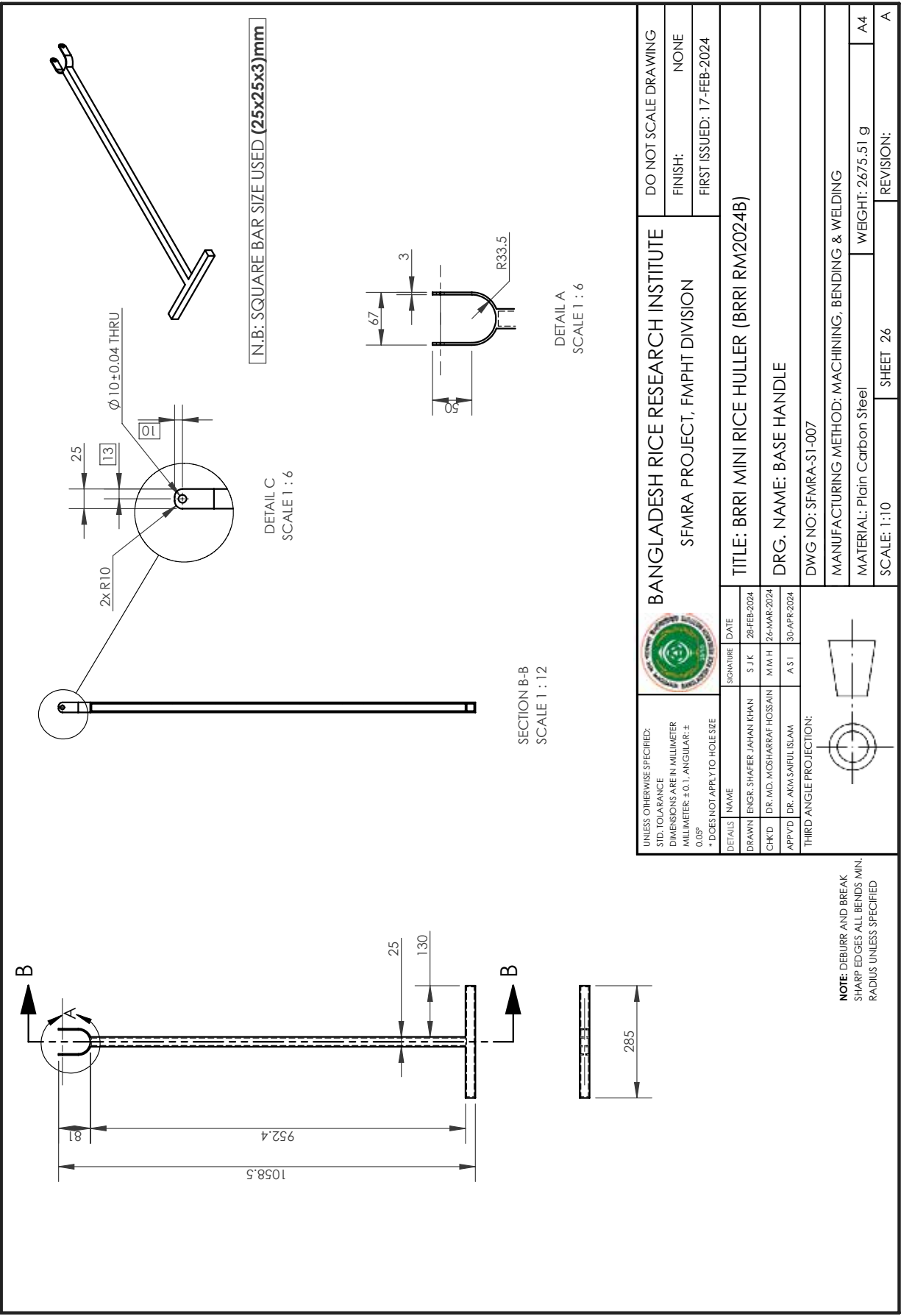

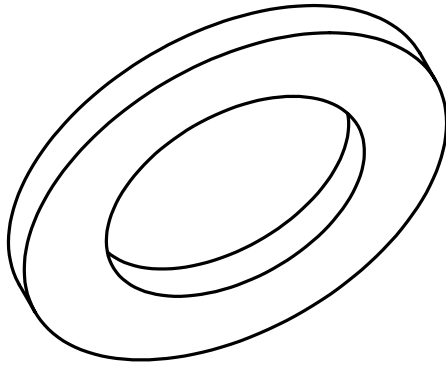

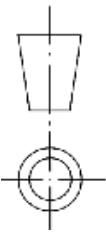

WASHER  
 INNER DIA: 22mm  
 OUTER DIA: 36mm  
 THICKNESS: 3mm  
 QUANTITY: 02

UNLESS OTHERWISE SPECIFIED: STD. TOLERANCE DIMENSIONS ARE IN MILLIMETER MILLIMETER: ±0.1, ANGULAR: ± 0.05° * DOES NOT APPLY TO HOLE SIZE		 <b>BANGLADESH RICE RESEARCH INSTITUTE</b> SFMRA PROJECT, FMPHT DIVISION		DO NOT SCALE DRAWING
DETAILS		SIGNATURE	DATE	FINISH: NONE
DRAWN	ENGR. SHAFER JAHAN KHAN	S J K	28-FEB-2024	FIRST ISSUED: 17-FEB-2024
CHK'D	DR. MD. MOSHARRAF HOSSAIN	M M H	26-MAR-2024	
APP'VD	DR. AKMAJILUL ISLAM	A S I	30-APR-2024	
THIRD ANGLE PROJECTION:				
TITLE: BRR I MINI RICE HULLER (BRR RM2024B)		DRG. NAME: WHEEL WASHER - 1		
DWG NO: SFMRA-S1-008		OUTSOURCING: VENDOR		
MATERIAL: Stainless Steel (ferritic)		WEIGHT: 14.92 g		
SCALE: 2:1		SHEET 27		
REVISION:		A		

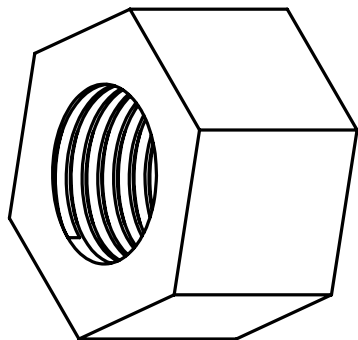
**NOTE:** DEBURR AND BREAK  
 SHARP EDGES ALL BENDS MIN.  
 RADIUS UNLESS SPECIFIED

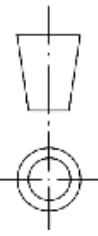

NUT: M16x2.0  
 QUANTITY: 02  
 \*\*\*FRONT WHEEL AXLE LOCK NUT.

UNLESS OTHERWISE SPECIFIED: STD. TOLERANCE DIMENSIONS ARE IN MILLIMETER MILLIMETER: ±0.1, ANGULAR: ± 0.05° * DOES NOT APPLY TO HOLE SIZE				BANGLADESH RICE RESEARCH INSTITUTE SFMRA PROJECT, FMPHT DIVISION		DO NOT SCALE DRAWING	
DETAILS		NAME	SIGNATURE	DATE	FINISH: NONE		
DRAWN		ENGR. SHAFIEE JAHAN KHAN	S J K	28-FEB-2024	FIRST ISSUED: 17-FEB-2024		
CHK'D		DR. MD. MOSHARRAF HOSSAIN	M M H	26-MAR-2024	TITLE: BRR I MINI RICE HULLER (BRR I RM2024B)		
APP'VD		DR. AKMA SAIFUL ISLAM	A S I	30-APR-2024	DRG. NAME: WHEEL NUT M14 (FRONT X2)		
THIRD ANGLE PROJECTION:				DWG NO: SFMRA-S1-009			REVISION: A
NOTE: DEBURR AND BREAK SHARP EDGES ALL BENDS MIN. RADIUS UNLESS SPECIFIED		OUTSOURCING: VENDOR		SCALE: 2:1			SHEET 28
		MATERIAL: Plain Carbon Steel		WEIGHT: 33.76 g			A4

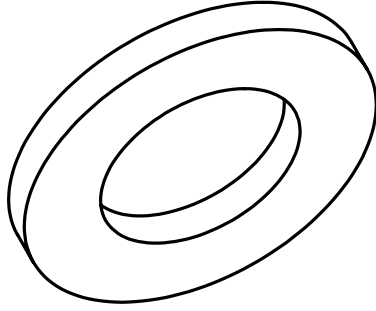

WASHER  
 INNER DIA: 17mm  
 OUTER DIA: 30mm  
 THICKNESS: 3mm  
 QUANTITY: 02

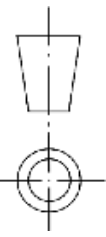
UNLESS OTHERWISE SPECIFIED: STD. TOLERANCE DIMENSIONS ARE IN MILLIMETER MILLIMETER: ±0.1, ANGULAR: ± 0.05° * DOES NOT APPLY TO HOLE SIZE		 <b>BANGLADESH RICE RESEARCH INSTITUTE</b> SFMRA PROJECT, FMPHT DIVISION		DO NOT SCALE DRAWING
TITLE: BRRI MINI RICE HULLER (BRRI RM2024B)		FINISH: NONE		FIRST ISSUED: 17-FEB-2024
DETAILS	NAME	SIGNATURE	DATE	
DRAWN	ENGR. SHAFER JAHAN KHAN	S J K	28-FEB-2024	
CHK'D	DR. MD. MOSHARRAF HOSSAIN	M M H	26-MAR-2024	
APP'VD	DR. AKMAJILUL ISLAM	A S I	30-APR-2024	
THIRD ANGLE PROJECTION:				
DRG. NAME: WHEEL WASHER - 2		DWG NO: SFMRA-S1-010		
OUTSOURCING: VENDOR				
MATERIAL: Plain Carbon Steel		WEIGHT: 11.23 g		A4
SCALE: 2:1		SHEET 29		REVISION:
				A

**NOTE:** DEBURR AND BREAK  
 SHARP EDGES ALL BENDS MIN.  
 RADIUS UNLESS SPECIFIED

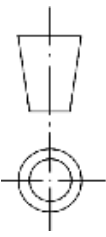

WASHER  
 INNER DIA: 16mm  
 OUTER DIA: 22mm  
 THICKNESS: 4mm  
 QUANTITY: 02

UNLESS OTHERWISE SPECIFIED: STD. TOLERANCE DIMENSIONS ARE IN MILLIMETER MILLIMETER: ±0.1, ANGULAR: ± 0.05° * DOES NOT APPLY TO HOLE SIZE		 BANGLADESH RICE RESEARCH INSTITUTE SFMRA PROJECT, FMPHT DIVISION		DO NOT SCALE DRAWING
DETAILS		SIGNATURE	DATE	FINISH: NONE
DRWN	ENGR. SHAFIEE JAHAN KHAN	S J K	28-FEB-2024	FIRST ISSUED: 17-FEB-2024
CHK'D	DR. MD. MOSHARRAF HOSSAIN	M M H	26-MAR-2024	
APP'VD	DR. AKMA SAIFUL ISLAM	A S I	30-APR-2024	
THIRD ANGLE PROJECTION:		TITLE: BRRI MINI RICE HULLER (BRRI RM2024B) DRG. NAME: WHEEL WASHER - 3 DWG NO: SFMRA-S1-011 SOURCING: VENDOR MATERIAL: Plain Carbon Steel SCALE: 2:1 SHEET: 30 WEIGHT: 5.59 g REVISION: A		
				

**NOTE:** DEBURR AND BREAK SHARP EDGES ALL BENDS MIN. RADIUS UNLESS SPECIFIED

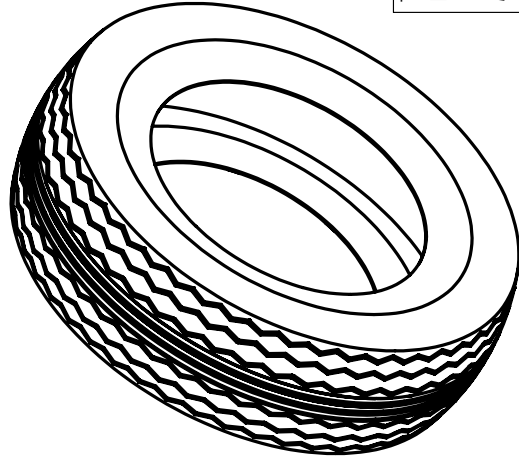

TIRE: 4-00-8 TIRE  
 Dimensions: Dia x Width 408mm x 118mm  
 Rim Size: 8"  
 Max Load: 265kg  
 Max Pressure: 4.1bar 59psi  
 QUANTITY: 03

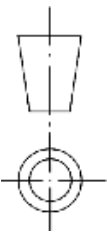
UNLESS OTHERWISE SPECIFIED: STD. TOLERANCE DIMENSIONS ARE IN MILLIMETER MILLIMETER: ±0.1, ANGULAR: ± 0.05° * DOES NOT APPLY TO HOLE SIZE				<b>BANGLADESH RICE RESEARCH INSTITUTE</b> SFMRA PROJECT, FMPHT DIVISION		DO NOT SCALE DRAWING	
DETAILS		NAME	SIGNATURE	DATE	FINISH: NONE		
DRAWN		ENGR. SHAFIEE JAHAN KHAN	S J K	28-FEB-2024	FIRST ISSUED: 17-FEB-2024		
CHK'D		DR. MD. MOSHARRAF HOSSAIN	M M H	26-MAR-2024	TITLE: BRR I MINI RICE HULLER (BRR I RM2024B)		
APP'VD		DR. AKMAJILUL ISLAM	A S I	30-APR-2024	DRG. NAME: TIRE A203107R 4-00-8		
THIRD ANGLE PROJECTION:				DWG NO: SFMRA-S1-012			WEIGHT: 1658.76 g
<b>NOTE: DEBURR AND BREAK          SHARP EDGES ALL BENDS MIN.          RADIUS UNLESS SPECIFIED</b>		OUTSOURCING: VENDOR		SCALE: 1:10			REVISION: A
		MATERIAL: Rubber		SHEET 31			A4

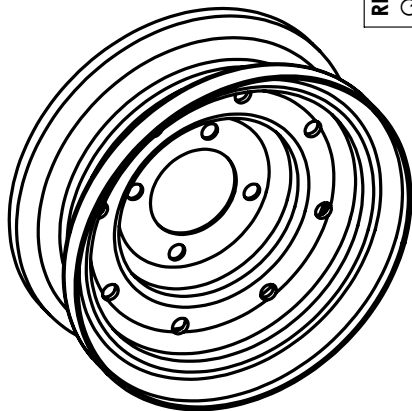

**RIM:** RIM FOR 4.00-8 TIRE  
**QUANTITY:** 03

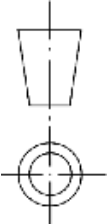
UNLESS OTHERWISE SPECIFIED: STD. TOLERANCE DIMENSIONS ARE IN MILLIMETER MILLIMETER: ±0.1, ANGULAR: ± 0.05° * DOES NOT APPLY TO HOLE SIZE		 <b>BANGLADESH RICE RESEARCH INSTITUTE</b> SFMRA PROJECT, FMPHT DIVISION		DO NOT SCALE DRAWING
DETAILS		NAME	SIGNATURE	DATE
DRWN	ENGR. SHAFIEE JAHAN KHAN	S J K		28-FEB-2024
CHK'D	DR. MD. MOSHARRAF HOSSAIN	M M H		26-MAR-2024
APP'VD	DR. AKMA SAIFUL ISLAM	A S I		30-APR-2024
THIRD ANGLE PROJECTION:				
TITLE: BRR I MINI RICE HULLER (BRR I RM2024B)		DRG. NAME: RIM		
DWG NO: SFMRA-S1-013		OUTSOURCING: VENDOR		
MATERIAL: ASTM A36 Steel		WEIGHT: 2310.39 g		
SCALE: 1:5		SHEET 32		
REVISION:		A		

**NOTE:** DEBURR AND BREAK SHARP EDGES ALL BENDS MIN. RADIUS UNLESS SPECIFIED

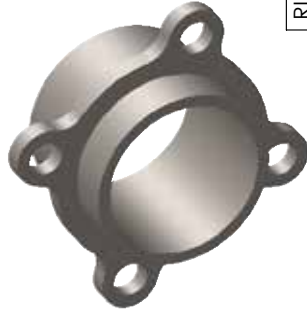

RIM HOLDING PART  
 INNER DIA: 52mm (THE BEARING 6205, WILL PLACE HERE)  
 HOLE DIA: 11mm  
 HOLE NUMBER: 04  
 QUANTITY: 03  
 [LOCALLY MADE]

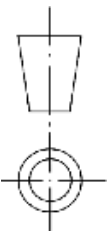
UNLESS OTHERWISE SPECIFIED: STD. TOLERANCE DIMENSIONS ARE IN MILLIMETER MILLIMETER: ±0.1, ANGULAR: ± 0.05° * DOES NOT APPLY TO HOLE SIZE		 <b>BANGLADESH RICE RESEARCH INSTITUTE</b> SFMRA PROJECT, FMPHT DIVISION		DO NOT SCALE DRAWING
DETAILS		SIGNATURE	DATE	FINISH: NONE
DRWN	ENGR. SHAFER JAHAN KHAN	S J K	28-FEB-2024	FIRST ISSUED: 17-FEB-2024
CHK'D	DR. MD. MOSHARRAF HOSSAIN	M M H	26-MAR-2024	
APP'VD	DR. AKMAJIBUL ISLAM	A S I	30-APR-2024	
THIRD ANGLE PROJECTION:				
TITLE: BRRI MINI RICE HULLER (BRRI RM2024B)				
DRG. NAME: RIM HOLDING PART				
DWG NO: SFMRA-S1-014				
OUTSOURCING: VENDOR				
MATERIAL: ASTM A36 Steel		WEIGHT: 2310.39 g		A4
SCALE: 1:2		SHEET 33		REVISION: A

**NOTE:** DEBURR AND BREAK SHARP EDGES ALL BENDS MIN. RADIUS UNLESS SPECIFIED

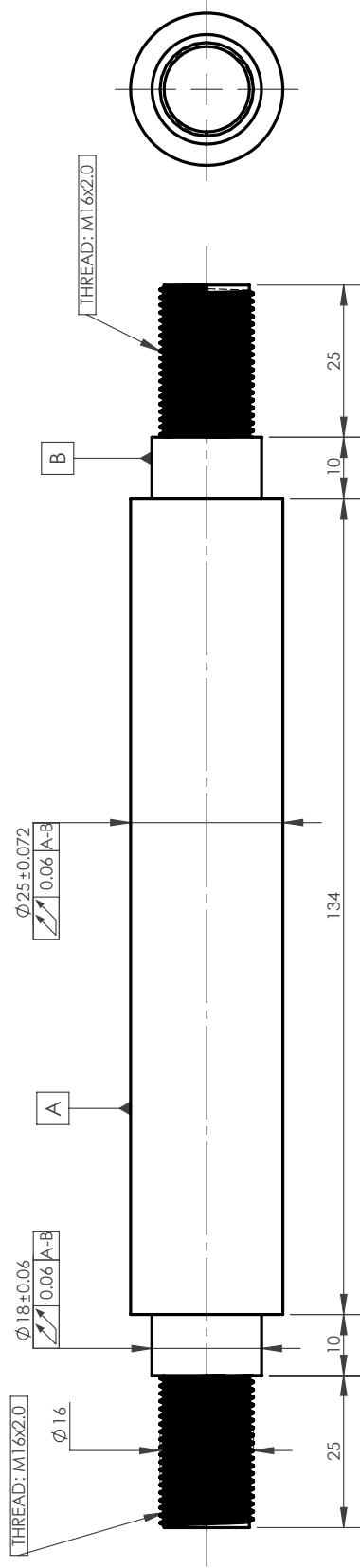
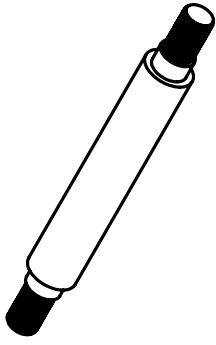

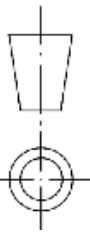

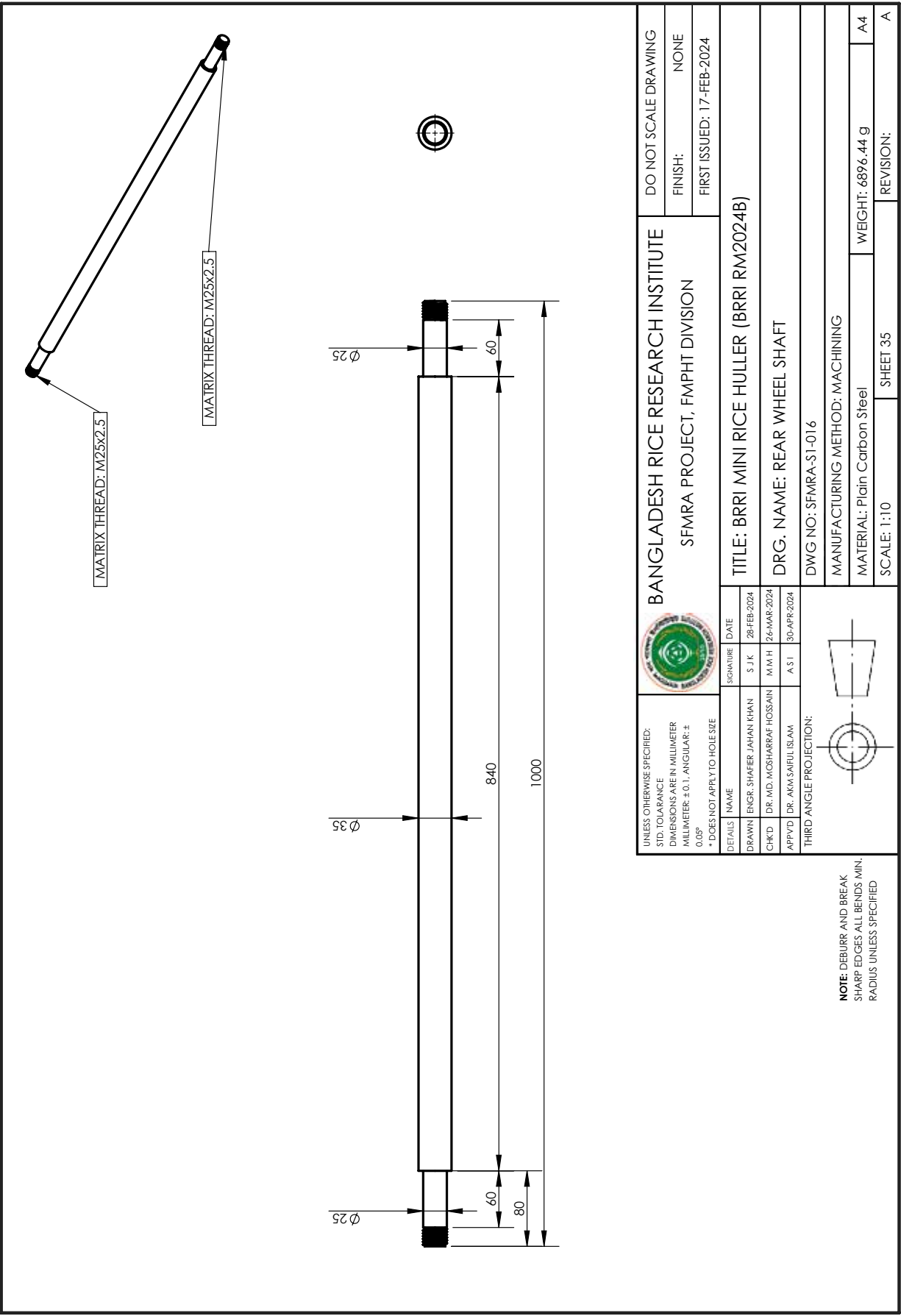
		BANGLADESH RICE RESEARCH INSTITUTE SFMRA PROJECT, FMPHT DIVISION		DO NOT SCALE DRAWING	
UNLESS OTHERWISE SPECIFIED: STD. TOLERANCE DIMENSIONS ARE IN MILLIMETER MILLIMETER: ±0.1, ANGULAR: ± 0.05° * DOES NOT APPLY TO HOLE SIZE		TITLE: BRRI MINI RICE HULLER (BRRI RM2024B)		FINISH: NONE FIRST ISSUED: 17-FEB-2024	
DETAILS NAME SIGNATURE DATE		DRG. NAME: RIM SHAFT FOR FRONT WHEEL		DWG NO: SFMRA-S1-015	
DRAWN ENGR. SHAFIEF JAHAN KHAN S J K 28-FEB-2024		DRG. NAME: RIM SHAFT FOR FRONT WHEEL		MANUFACTURING METHOD: MACHINING	
CHKD DR. MD. MOSHARRAF HOSSAIN M M H 26-MAR-2024		DRG. NAME: RIM SHAFT FOR FRONT WHEEL		MATERIAL: Plain Carbon Steel	
APPVD DR. AKMAJAIUL ISLAM A S I 30-APR-2024		THIRD ANGLE PROJECTION:		SCALE: 1:2	
* DOES NOT APPLY TO HOLE SIZE				WEIGHT: 617.96 g	
NOTE: DEBURR AND BREAK SHARP EDGES ALL BENDS MIN. RADIUS UNLESS SPECIFIED		SHEET 34		REVISION: A	

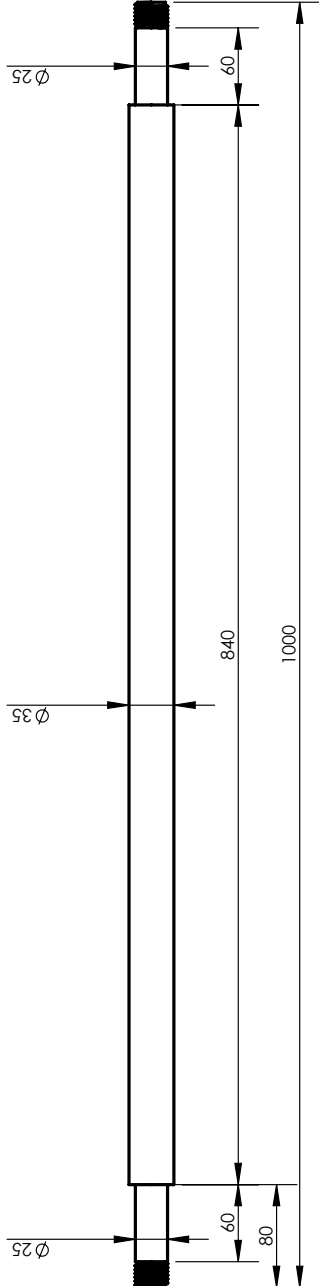

MATRIX THREAD: M25x2.5

MATRIX THREAD: M25x2.5

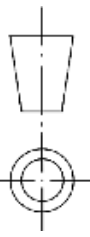

UNLESS OTHERWISE SPECIFIED: STD. TOLERANCE DIMENSIONS ARE IN MILLIMETER MILLIMETER: ±0.1, ANGULAR: ± 0.05° * DOES NOT APPLY TO HOLE SIZE				<b>BANGLADESH RICE RESEARCH INSTITUTE</b> SFMRA PROJECT, FMPHT DIVISION		DO NOT SCALE DRAWING	
DETAILS	NAME	SIGNATURE	DATE	<b>TITLE: BRR MINI RICE HULLER (BRR RM2024B)</b>		FINISH: NONE	
DRAWN	ENGR. SHAFER JAHAN KHAN	S J K	28-FEB-2024	DRG. NAME: REAR WHEEL SHAFT		FIRST ISSUED: 17-FEB-2024	
CHK'D	DR. MD. MOSHARRAF HOSSAIN	M M H	26-MAR-2024	DWG NO: SFMRA-S1-016			
APP'VD	DR. AKMA SAIFUL ISLAM	A S I	30-APR-2024	MANUFACTURING METHOD: MACHINING			
THIRD ANGLE PROJECTION:							
<b>NOTE: DEBURR AND BREAK SHARP EDGES ALL BENDS MIN. RADIUS UNLESS SPECIFIED</b>				MATERIAL: Plain Carbon Steel		WEIGHT: 6896.44 g	
				SCALE: 1:10		REVISION:	
				SHEET 35		A	

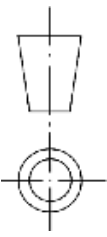

BALL BEARING: 6205  
 INNER DIA: 25mm  
 OUTER DIA: 52mm  
 QUANTITY: 06 (FOR WHEELS)

UNLESS OTHERWISE SPECIFIED: STD. TOLERANCE DIMENSIONS ARE IN MILLIMETER MILLIMETER: ±0.1, ANGULAR: ± 0.05° * DOES NOT APPLY TO HOLE SIZE				BANGLADESH RICE RESEARCH INSTITUTE SFMRA PROJECT, FMPHT DIVISION		DO NOT SCALE DRAWING	
DETAILS	NAME	SIGNATURE	DATE				
DRAWN	ENGR. SHAFIEE JAHAN KHAN	S J K	28-FEB-2024	TITLE: BRRI MINI RICE HULLER (BRRI RM2024B)			
CHK'D	DR. MD. MOSHARRAF HOSSAIN	M M H	26-MAR-2024	DRG. NAME: 6205 RS BEARING			
APP'VD	DR. AKMAJAIUL ISLAM	A S I	30-APR-2024	DWG NO: SFMRA-S1-017			
THIRD ANGLE PROJECTION:							
			OUTSOURCING: VENDOR				
			WEIGHT: 0.02 g				
			SCALE: 1:1				
			SHEET 36				
			REVISION: A				

**NOTE:** DEBURR AND BREAK  
 SHARP EDGES ALL BENDS MIN.  
 RADIUS UNLESS SPECIFIED

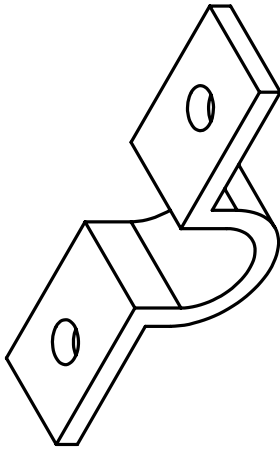

N.B: MODEL IS SYMMETRY.  
ONLY ONE SIDE DIMENSIONS HAS SHOWN FOR HOLES.

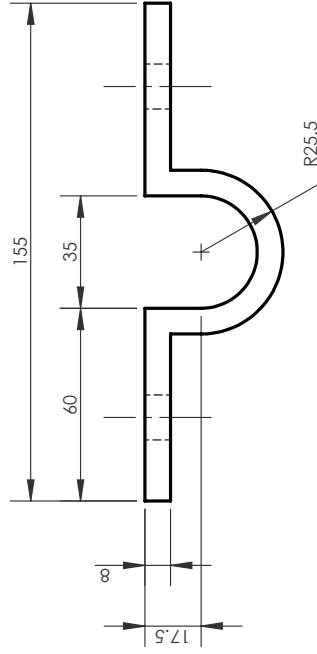
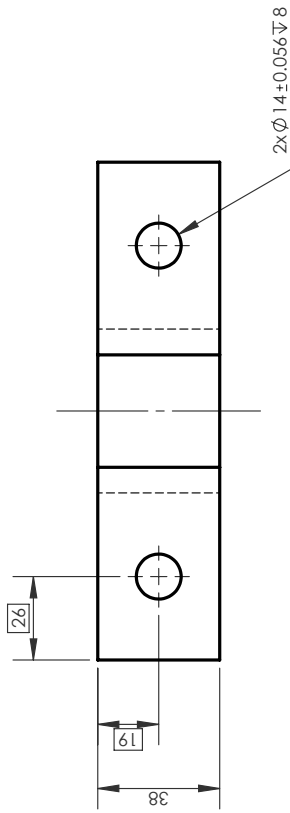

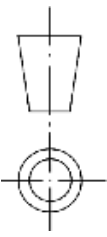
UNLESS OTHERWISE SPECIFIED: STD. TOLERANCE DIMENSIONS ARE IN MILLIMETER MILLIMETER: ±0.1, ANGULAR: ± 0.05° * DOES NOT APPLY TO HOLE SIZE		 <b>BANGLADESH RICE RESEARCH INSTITUTE</b> SFMRA PROJECT, FMPHT DIVISION		DO NOT SCALE DRAWING
DETAILS	NAME	SIGNATURE	DATE	FINISH: NONE
DRAWN	ENGR. SHAFER JAHAN KHAN	S J K	28-FEB-2024	FIRST ISSUED: 17-FEB-2024
CHK'D	DR. MD. MOSHARRAF HOSSAIN	M M H	26-MAR-2024	
APP'VD	DR. AKMAJIBUL ISLAM	A S I	30-APR-2024	
THIRD ANGLE PROJECTION:				
TITLE: BRRI MINI RICE HULLER (BRRI RM2024B)		DRG. NAME: SHAFT HOLDER		
DWG NO: SFMRA-S1-018		MANUFACTURING METHOD: MACHINING, BENDING & WELDING		
MATERIAL: Plain Carbon Steel		WEIGHT: 470.55 g		
SCALE: 1:2		REVISION: A		

NOTE: DEBURR AND BREAK  
SHARP EDGES ALL BENDS MIN.  
RADIUS UNLESS SPECIFIED

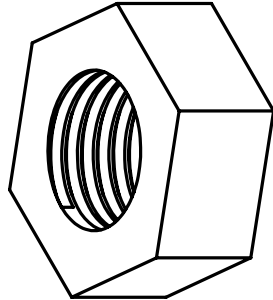

REAR WHEEL AXLE LOCK NUT  
 SIZE: M25x3.0  
 QUANTITY: 02

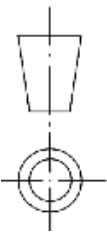
UNLESS OTHERWISE SPECIFIED: STD. TOLERANCE DIMENSIONS ARE IN MILLIMETER MILLIMETER: ±0.1, ANGULAR: ± 0.05° * DOES NOT APPLY TO HOLE SIZE		 BANGLADESH RICE RESEARCH INSTITUTE SFMRA PROJECT, FMPHT DIVISION		DO NOT SCALE DRAWING
DETAILS	NAME	SIGNATURE	DATE	FINISH: NONE
DRAWN	ENGR. SHAFIEE JAHAN KHAN	S J K	28-FEB-2024	FIRST ISSUED: 17-FEB-2024
CHK'D	DR. MD. MOSHARRAF HOSSAIN	M M H	26-MAR-2024	
APP'VD	DR. AKMA SAIFUL ISLAM	A S I	30-APR-2024	
THIRD ANGLE PROJECTION:				
		TITLE: BRR I MINI RICE HULLER (BRR I RM2024B)		
				DRG. NAME: WHEEL SHAFT NUT M25 (REAR)
				DWG NO: SFMRA-S1-018
				OUTSOURCING: VENDOR
			MATERIAL: Stainless Steel (ferritic)	WEIGHT: 127.77 g
			SCALE: 1:1	SHEET 38
			REVISION:	A

**NOTE:** DEBURR AND BREAK SHARP EDGES ALL BENDS MIN. RADIUS UNLESS SPECIFIED

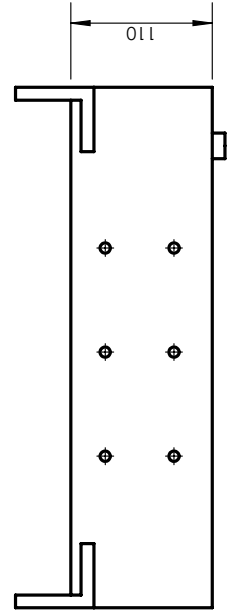
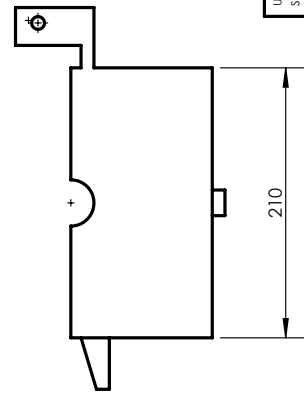
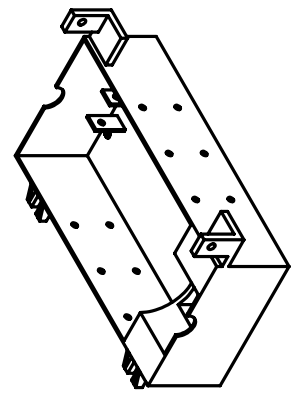
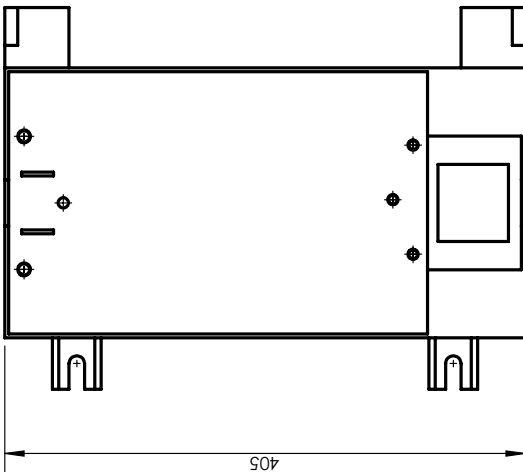

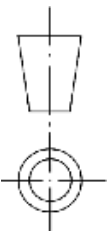
UNLESS OTHERWISE SPECIFIED: STD. TOLERANCE DIMENSIONS ARE IN MILLIMETER MILLIMETER: ±0.1, ANGULAR: ± 0.05° * DOES NOT APPLY TO HOLE SIZE		 <b>BANGLADESH RICE RESEARCH INSTITUTE</b> SFMRA PROJECT, FMPHT DIVISION		DO NOT SCALE DRAWING
DETAILS	NAME	SIGNATURE	DATE	FINISH: NONE
DRAWN	ENGR. SHAFER JAHAN KHAN	S J K	28-FEB-2024	FIRST ISSUED: 17-FEB-2024
CHK'D	DR. MD. MOSHARRAF HOSSAIN	M M H	26-MAR-2024	
APP'VD	DR. AKMA SAIFUL ISLAM	A S I	30-APR-2024	
THIRD ANGLE PROJECTION:				
		<b>TITLE: BRRI MINI RICE HULLER (BRRI RM2024B)</b> <b>DRG. NAME: BODY TOP COVER SUPPORT SQUARE BAR (8X8)MM</b> <b>DWG NO: SFMRA-32-019</b> <b>MANUFACTURING METHOD: MACHINING, BENDING &amp; WELDING</b> <b>MATERIAL: PLAIN CARBON STEEL</b> <b>WEIGHT: 6488.34 g</b> <b>SCALE: 1:4</b> <b>SHEET 39</b>		
			REVISION:	A
				A4

**NOTE:** DEBURR AND BREAK SHARP EDGES ALL BENDS MIN. RADIUS UNLESS SPECIFIED

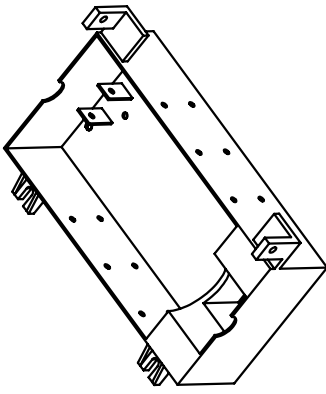

N.B: MODEL IS SYMMETRY.  
 \*NOT A COMPLETE DRAWING.  
 \*ONLY FRONT VIEW & SECTION B-B FROM FRONT VIEW DIMENSIONS HAS SHOWN IN THIS SHEET.  
 \*SHEET THICKNESS: 3mm

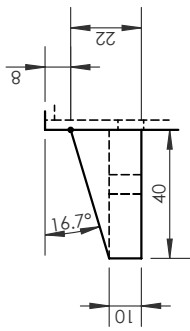

DETAIL A  
 SCALE 1 : 2

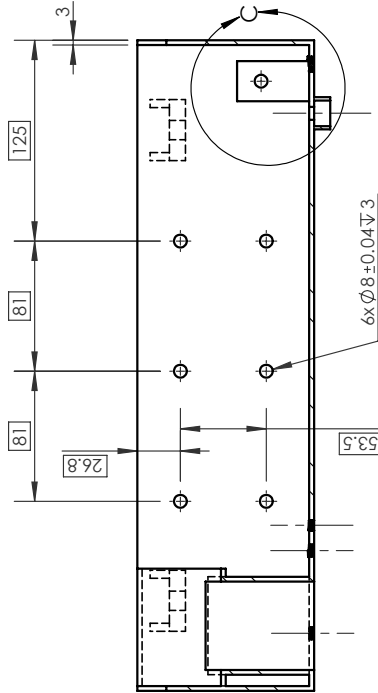
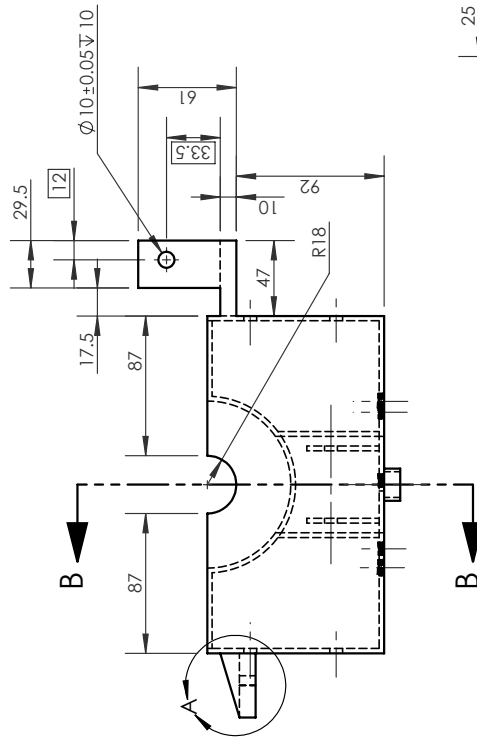

SECTION B-B

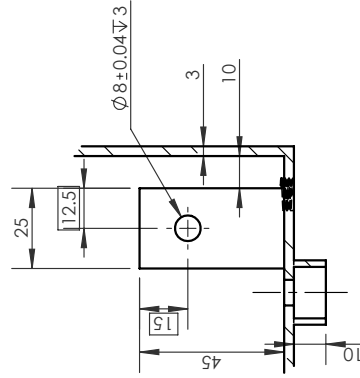

DETAIL C  
 SCALE 1 : 2

DWG NO: SFMRA-S2-019  
 SHEET NO: 40

N.B.: MODEL IS SYMMETRY.  
 \*NOT A COMPLETE DRAWING.  
 \*ONLY RIGHT VIEW & SECTION FROM RIGHT  
 VIEW DIMENSIONS HAS SHOWN IN THIS SHEET.  
 \*SHEET THICKNESS: 3mm

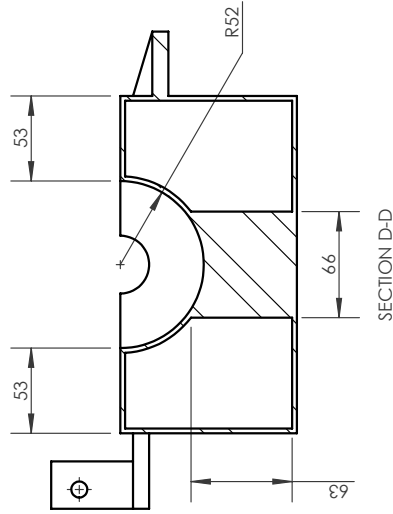
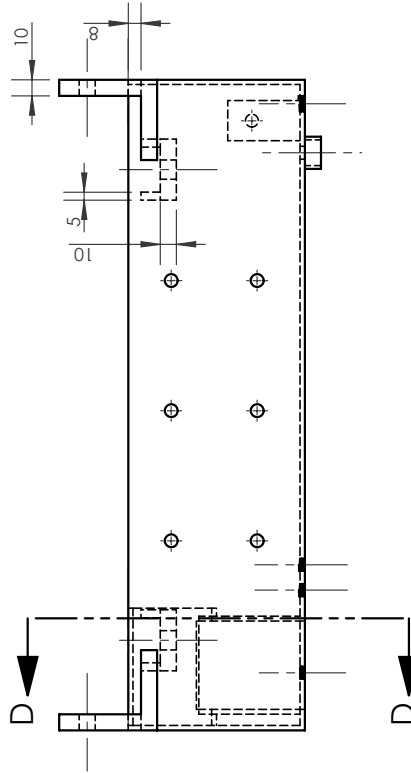
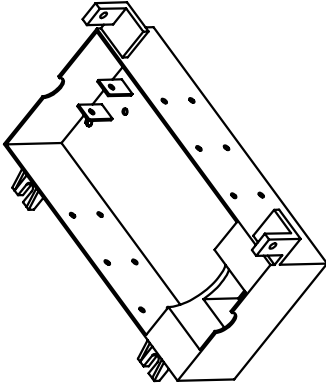

DWG NO: SFMRA-S2-019  
 SHEET NO: 41

N.B: BLUE COLOR DIMENSIONS IS FOR THE PLACEMENT OF PRESSURE CONTROL DEVICE.

N.B: PURPLE COLOR DIMENSIONS IS FOR THE PLACEMENT OF HOPPER.

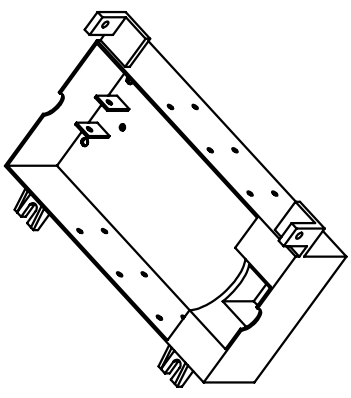
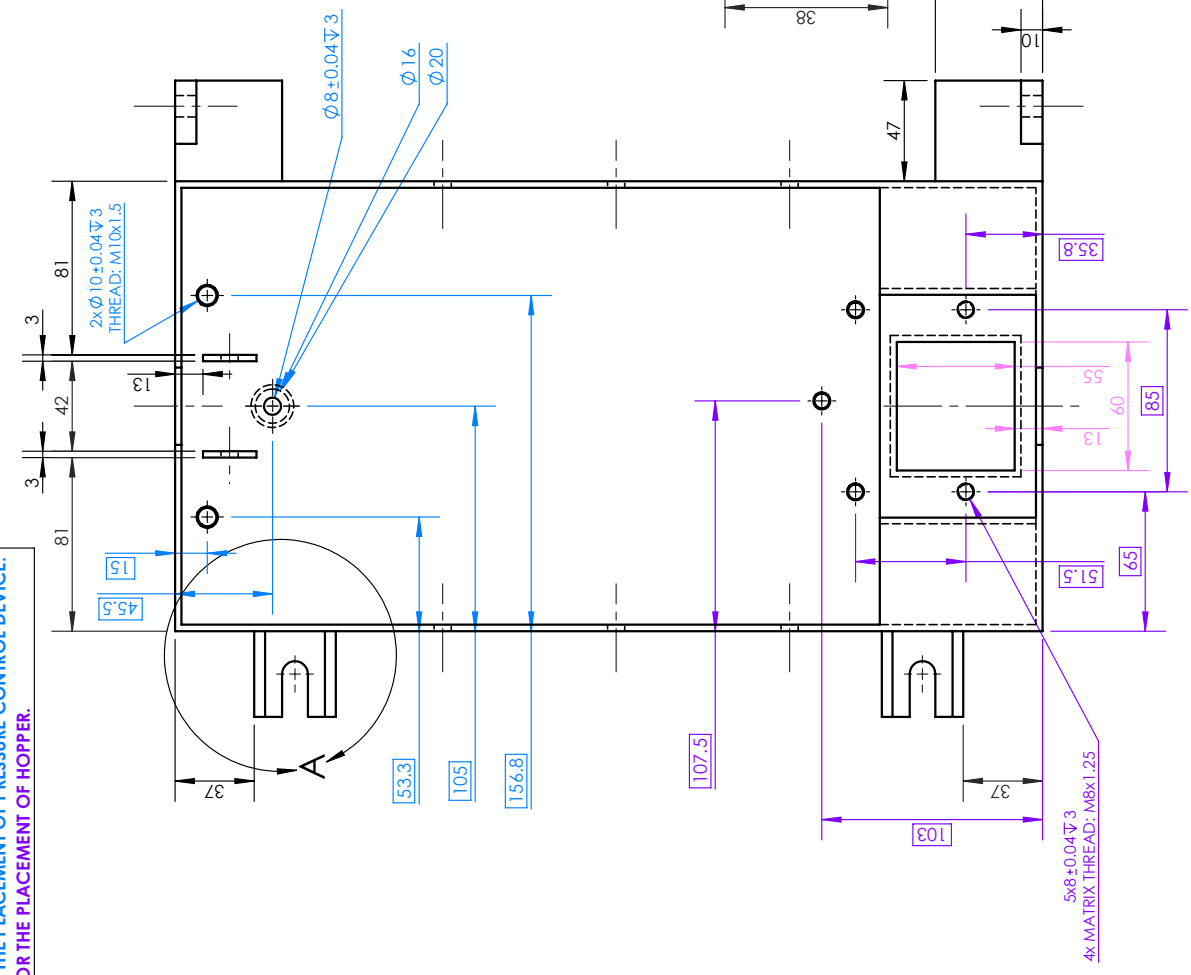

N.B: MODEL IS SYMMETRY.  
\*NOT A COMPLETE DRAWING.  
\*ONLY TOP VIEW DIMENSIONS HAS SHOWN IN THIS SHEET.

DETAIL A  
SCALE 2:3

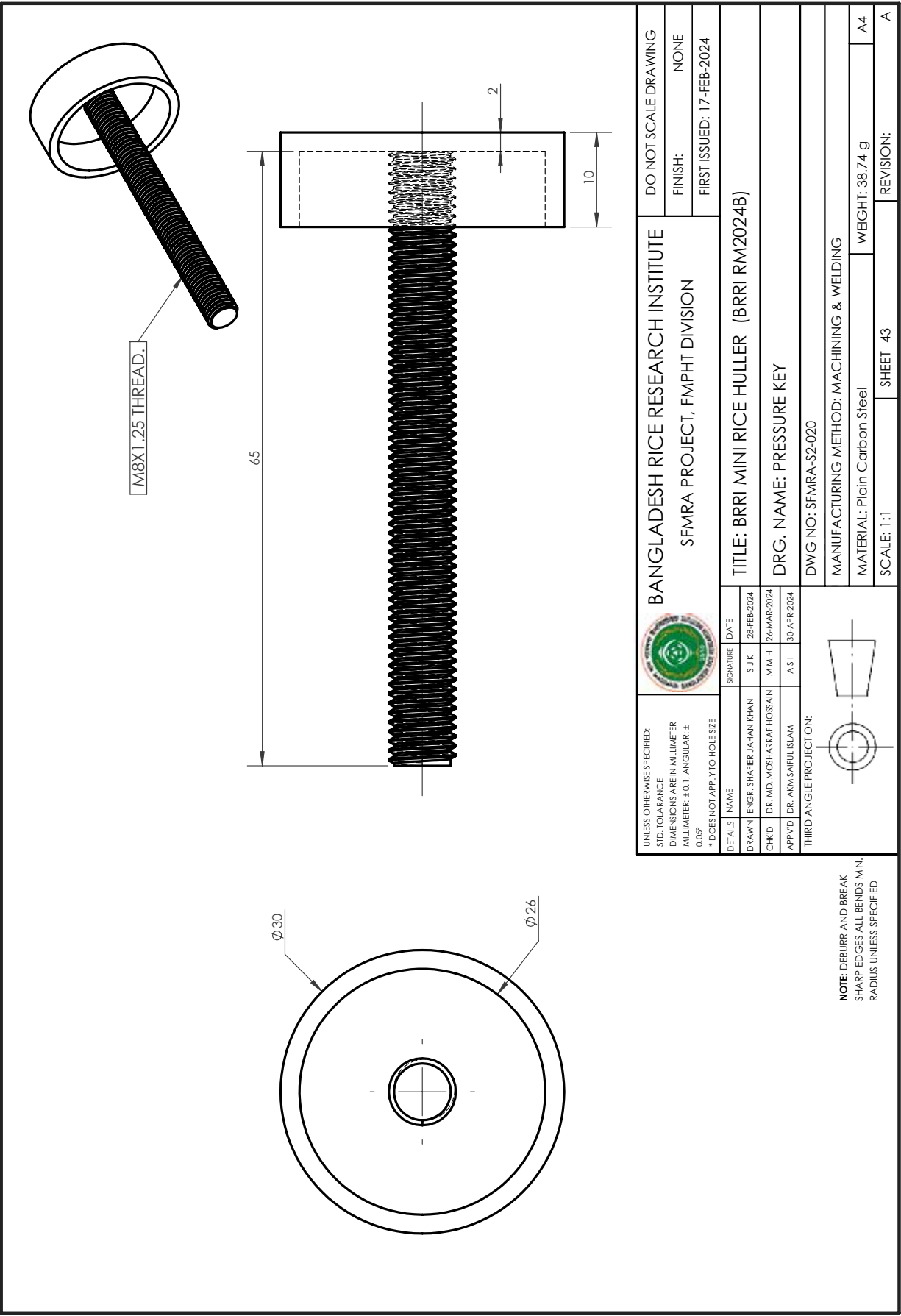

**NOTE:** DEBURR AND BREAK SHARP EDGES ALL BENDS MIN. RADIUS UNLESS SPECIFIED

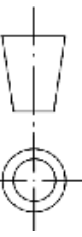
UNLESS OTHERWISE SPECIFIED: STD. TOLERANCE DIMENSIONS ARE IN MILLIMETER MILLIMETER: ±0.1, ANGULAR: ±0.05° * DOES NOT APPLY TO HOLE SIZE				<b>BANGLADESH RICE RESEARCH INSTITUTE</b> SFMRA PROJECT, FMPHT DIVISION		DO NOT SCALE DRAWING
DETAILS	NAME	SIGNATURE	DATE	<b>TITLE: BRI MINI RICE HULLER (BRI RM2024B)</b>		FINISH: NONE
DRAWN	ENGR. SHAFER JAHAN KHAN	S J K	28-FEB-2024	<b>DRG. NAME: PRESSURE KEY</b>		FIRST ISSUED: 17-FEB-2024
CHK'D	DR. MD. MOSHARRAF HOSSAIN	M M H	26-MAR-2024	<b>DWG NO: SFMRA-S2-020</b>		
APP'VD	DR. AKMA SAIFUL ISLAM	A S I	30-APR-2024	<b>MANUFACTURING METHOD: MACHINING &amp; WELDING</b>		
THIRD ANGLE PROJECTION:						
				<b>MATERIAL: Plain Carbon Steel</b>		WEIGHT: 38.74 g
				<b>SCALE: 1:1</b>		REVISION: A
				<b>SHEET 43</b>		A4

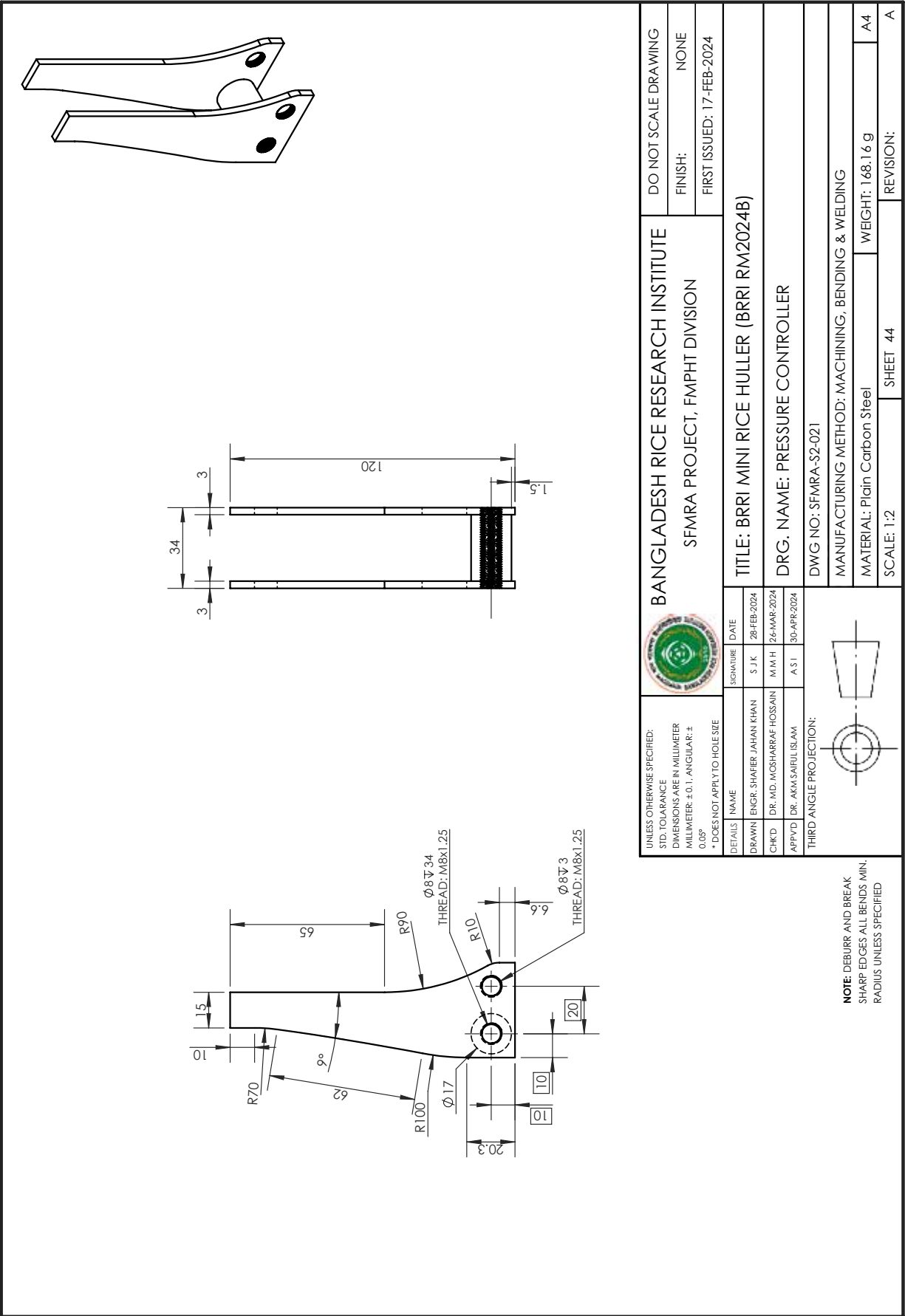

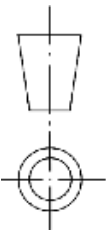
UNLESS OTHERWISE SPECIFIED: STD. TOLERANCE DIMENSIONS ARE IN MILLIMETER MILLIMETER: ±0.1, ANGULAR: ± 0.05° * DOES NOT APPLY TO HOLE SIZE				<b>BANGLADESH RICE RESEARCH INSTITUTE</b> SFMRA PROJECT, FMPHT DIVISION		DO NOT SCALE DRAWING	
DETAILS	NAME	SIGNATURE	DATE				
DRAWN	ENGR. SHAFER JAHAN KHAN	S J K	28-FEB-2024				
CHK'D	DR. MD. MOSHARRAF HOSSAIN	M M H	26-MAR-2024	TITLE: BRRI MINI RICE HULLER (BRRI RM2024B)			
APP'VD	DR. AKMAJIBUL ISLAM	A S I	30-APR-2024	DRG. NAME: PRESSURE CONTROLLER			
THIRD ANGLE PROJECTION:							
NOTE: DEBURR AND BREAK SHARP EDGES ALL BENDS MIN. RADIUS UNLESS SPECIFIED			DWG NO: SFMRA-32-021 MANUFACTURING METHOD: MACHINING, BENDING & WELDING MATERIAL: Plain Carbon Steel SCALE: 1:2 SHEET 44 REVISION: A				

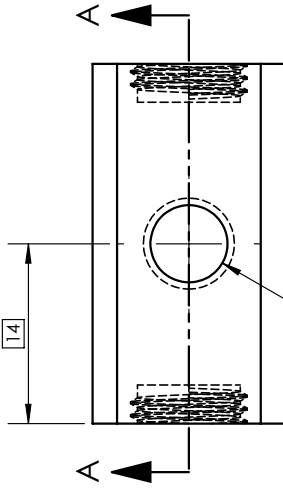
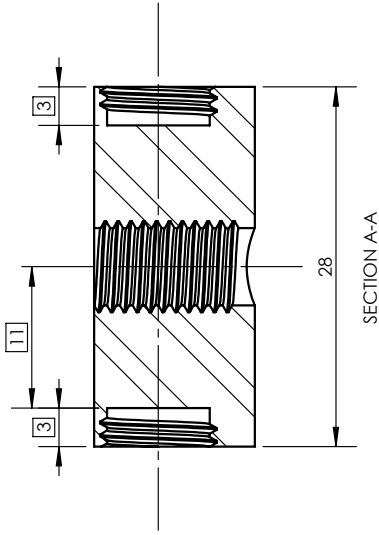
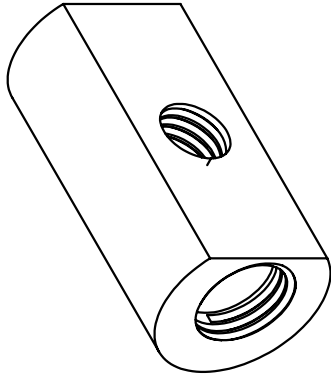

$\phi 8 \pm 0.043$   
MATRIX THREAD: M8x1.25  
THREAD LENGTH: 2.5mm

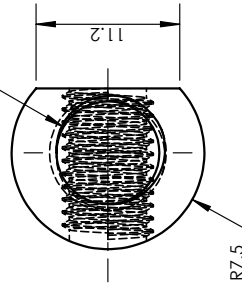

$\phi 6 \pm 0.036$  THRU  
MATRIX THREAD: M6x1.0

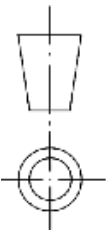
UNLESS OTHERWISE SPECIFIED: STD. TOLERANCE DIMENSIONS ARE IN MILLIMETER MILLIMETER: ±0.1, ANGULAR: ± 0.05° * DOES NOT APPLY TO HOLE SIZE		 <b>BANGLADESH RICE RESEARCH INSTITUTE</b> SFMRA PROJECT, FMPHT DIVISION		DO NOT SCALE DRAWING
DETAILS		NAME	SIGNATURE	DATE
DRAWN	ENGR. SHAHEER JAHAN KHAN	S J K		28-FEB-2024
CHK'D	DR. MD. MOSHARRAF HOSSAIN	M M H		26-MAR-2024
APP'VD	DR. AKMA SAIFUL ISLAM	A S I		30-APR-2024
THIRD ANGLE PROJECTION:				
<b>TITLE: BRRI MINI RICE HULLER (BRRI RM2024B)</b> <b>DRG. NAME: PRESSURE CLAMP PIN</b> <b>DWG NO: SFMRA-52-022</b> <b>MANUFACTURING METHOD: MACHINING</b> <b>MATERIAL: Plain Carbon Steel</b> <b>SCALE: 2:1</b> <b>WEIGHT: 28.65 g</b> <b>SHEET 45</b> <b>REVISION: A</b>				
FINISH: NONE		FIRST ISSUED: 17-FEB-2024		

**NOTE:** DEBURR AND BREAK  
SHARP EDGES ALL BENDS MIN.  
RADIUS UNLESS SPECIFIED

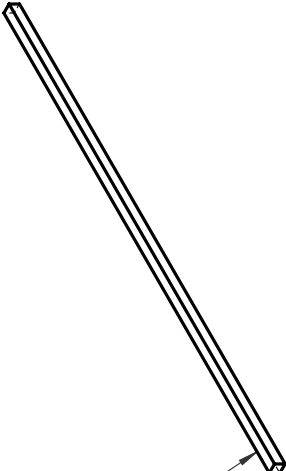

**QUANTITY: 04**

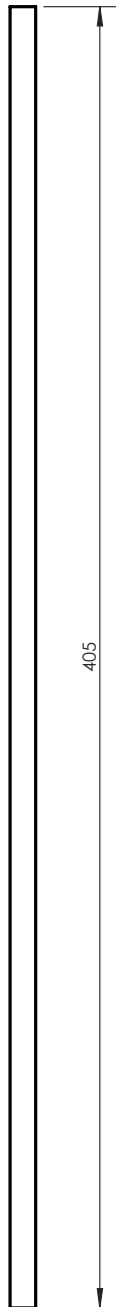

405

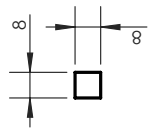

 <b>BANGLADESH RICE RESEARCH INSTITUTE</b> SFMRA PROJECT, FMPHT DIVISION		DO NOT SCALE DRAWING	
		FINISH:	NONE
		FIRST ISSUED: 17-FEB-2024	
<b>TITLE: BRRI MINI RICE HULLER (BRRI RM2024B)</b>			
DRG. NAME: SQUARE BAR			
DWG NO: SFMRA-S2-023			
MANUFACTURING METHOD: MACHINING			
MATERIAL: Plain Carbon Steel		WEIGHT: 202.18 g	
SCALE: 1:2		SHEET 46	
		REVISION: A	

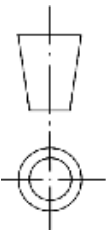

UNLESS OTHERWISE SPECIFIED: STD. TOLERANCE DIMENSIONS ARE IN MILLIMETER MILLIMETER: ±0.1, ANGULAR: ± 0.05° * DOES NOT APPLY TO HOLE SIZE		 THIRD ANGLE PROJECTION:	
DETAILS	NAME		
DRAWN	ENGR. SHAFIEE JAHAN KHAN	S J K	28-FEB-2024
CHK'D	DR. MD. MOSHARRAF HOSSAIN	M M H	26-MAR-2024
APP'VD	DR. AKM SAIFUL ISLAM	A S I	30-APR-2024

**NOTE:** DEBURR AND BREAK SHARP EDGES ALL BENDS MIN. RADIUS UNLESS SPECIFIED

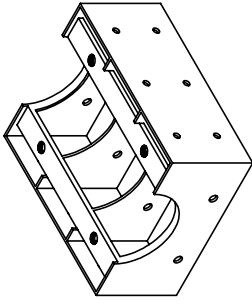

\*MODEL IS SYMMETRY.  
 \*SHEET THICKNESS: 3mm  
 \*FLAT BAR THICKNESS: 6mm.

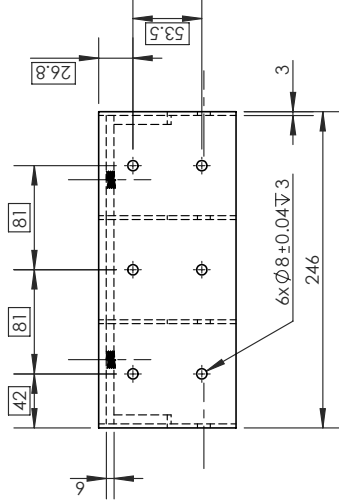
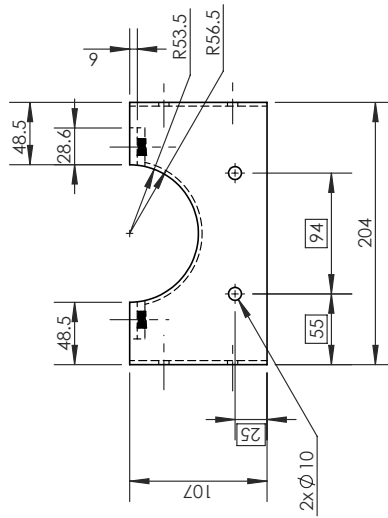
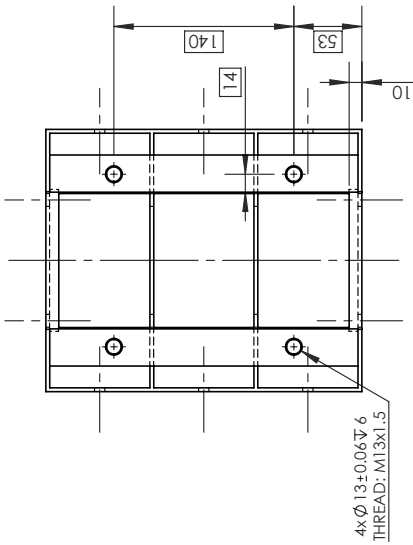

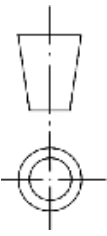
UNLESS OTHERWISE SPECIFIED: STD. TOLERANCE DIMENSIONS ARE IN MILLIMETER MILLIMETER: ±0.1, ANGULAR: ±0.05° * DOES NOT APPLY TO HOLE SIZE		 <b>BANGLADESH RICE RESEARCH INSTITUTE</b> SFMRA PROJECT, FMPHT DIVISION		DO NOT SCALE DRAWING
DETAILS	NAME	SIGNATURE	DATE	FINISH: NONE
DRAWN	ENGR. SHAFIEE JAHAN KHAN	S J K	28-FEB-2024	FIRST ISSUED: 17-FEB-2024
CHK'D	DR. MD. MOSHARRAF HOSSAIN	M M H	26-MAR-2024	
APP'VD	DR. AKMA SAIFUL ISLAM	A S I	30-APR-2024	
THIRD ANGLE PROJECTION:				
		<b>TITLE: BRRI MINI RICE HULLER (BRRI RM2024B)</b> <b>DRG. NAME: NET FRAME</b> <b>DWG NO: SFMRA-S2-024</b>		
<b>MANUFACTURING METHOD: MACHINING, BENDING &amp; WELDING</b>				
<b>MATERIAL: Plain Carbon Steel</b>		<b>WEIGHT: 3420.79 g</b>		A4
<b>SCALE: 1:5</b>		<b>SHEET 47</b>		REVISION: A

**NOTE: DEBURR AND BREAK SHARP EDGES ALL BENDS MIN. RADIUS UNLESS SPECIFIED**

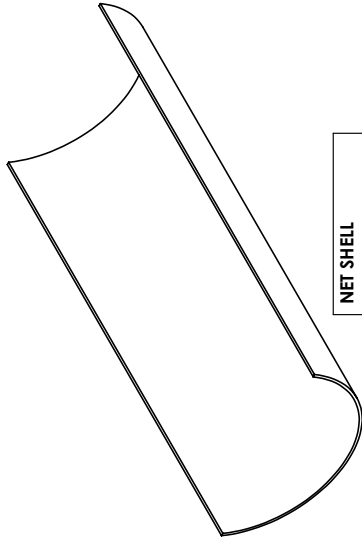

**NET SHELL**  
**THICKNESS: 1.5mm**  
**LENGTH: 245mm**  
**RADIUS: 52mm**  
**QUANTITY: 02**

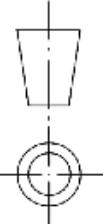
UNLESS OTHERWISE SPECIFIED: STD. TOLERANCE DIMENSIONS ARE IN MILLIMETER MILLIMETER: ±0.1, ANGULAR: ± 0.05° * DOES NOT APPLY TO HOLE SIZE		 <b>BANGLADESH RICE RESEARCH INSTITUTE</b> SFMRA PROJECT, FMPHT DIVISION		DO NOT SCALE DRAWING
DETAILS		NAME	SIGNATURE	DATE
DRAWN	ENGR. SHAFIEE JAHAN KHAN	S J K		28-FEB-2024
CHK'D	DR. MD. MOSHARRAF HOSSAIN	M M H		26-MAR-2024
APP'VD	DR. AKMAJIBUL ISLAM	A S I		30-APR-2024
THIRD ANGLE PROJECTION:				
TITLE: BRR I MINI RICE HULLER (BRR I RM2024B)		DRG. NAME: NET		
DWG NO: SFMRA-S2-025		OUTSOURCING: VENDOR		
MATERIAL: Plain Carbon Steel		WEIGHT: 440.56 g		
SCALE: 1:5		SHEET 48		
REVISION:		A		

**NOTE:** DEBURR AND BREAK  
 SHARP EDGES ALL BENDS MIN.  
 RADIUS UNLESS SPECIFIED

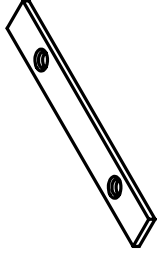
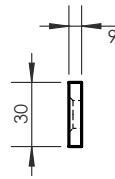
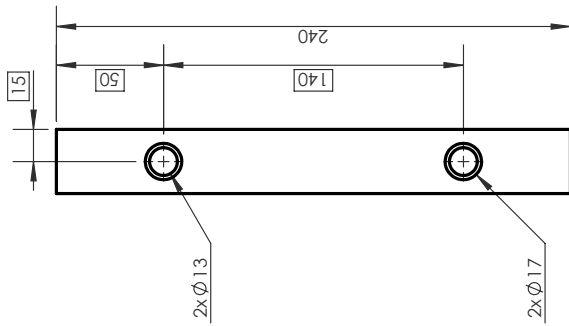

\*MODEL SYMMETRY.  
\*QUANTITY: 04

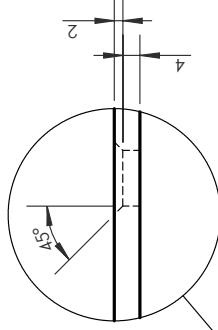

DETAIL A  
SCALE 2 : 3

**NOTE:** DEBURR AND BREAK SHARP EDGES ALL BENDS MIN. RADIUS UNLESS SPECIFIED

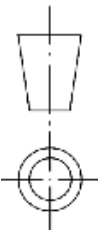
UNLESS OTHERWISE SPECIFIED: STD. TOLERANCE DIMENSIONS ARE IN MILLIMETER MILLIMETER: ±0.1, ANGULAR: ± 0.05° * DOES NOT APPLY TO HOLE SIZE		 <b>BANGLADESH RICE RESEARCH INSTITUTE</b> SFMRA PROJECT, FMPHT DIVISION		DO NOT SCALE DRAWING
DETAILS	NAME	SIGNATURE	DATE	FINISH: NONE
DRAWN	ENGR. SHAFER JAHAN KHAN	S J K	28-FEB-2024	FIRST ISSUED: 17-FEB-2024
CHK'D	DR. MD. MOSHARRAF HOSSAIN	M M H	26-MAR-2024	
APP'VD	DR. AKMA SAIFUL ISLAM	A S I	30-APR-2024	
THIRD ANGLE PROJECTION: 				
<b>TITLE: BRRI MINI RICE HULLER (BRRI RM2024B)</b> <b>DRG. NAME: FLAT BAT THICKNESS 6mm</b> <b>DWG NO: SFMRA-52-026</b> <b>MANUFACTURING METHOD: MACHINING</b> <b>MATERIAL: Plain Carbon Steel</b> <b>SCALE: 1:5</b>				
WEIGHT: 323.13 g			REVISION: A	
SHEET 49			A4	

\*QUANTITY : 04

246

Ø 10

		SIGNATURE	DATE
		S J K	28-FEB-2024
<b>BANGLADESH RICE RESEARCH INSTITUTE</b> SFMRA PROJECT, FMPHT DIVISION			
<b>TITLE: BRRI MINI RICE HULLER (BRRI RM2024B)</b>			
DRG. NAME: ROD			
DWG NO: SFMRA-52-027			
MANUFACTURING METHOD: MACHINING			
MATERIAL: Plain Carbon Steel		WEIGHT: 150.70 g	
SCALE: 1:5		SHEET 50	
REVISION:		A	

**NOTE:** DEBURR AND BREAK SHARP EDGES ALL BENDS MIN. RADIUS UNLESS SPECIFIED

THIRD ANGLE PROJECTION:

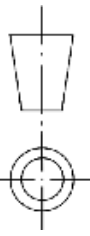

UNLESS OTHERWISE SPECIFIED:  
 STD. TOLERANCE DIMENSIONS ARE IN MILLIMETER  
 MILLIMETER: ±0.1, ANGULAR: ±0.05°  
 \* DOES NOT APPLY TO HOLE SIZE

DETAILS	NAME	SIGNATURE	DATE
DRAWN	ENGR. SHAFIEE JAHAN KHAN	S J K	28-FEB-2024
CHK'D	DR. MD. MOSHARRAF HOSSAIN	M M H	26-MAR-2024
APP'VD	DR. AKMASAIFUL ISLAM	A S I	30-APR-2024

DO NOT SCALE DRAWING

FINISH: NONE

FIRST ISSUED: 17-FEB-2024

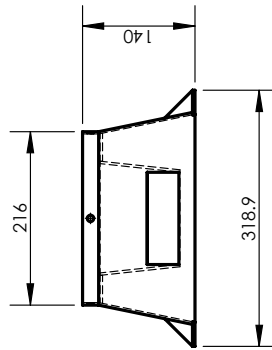
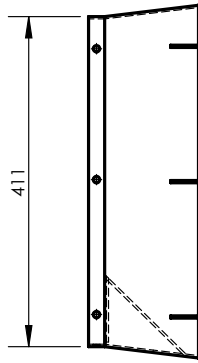
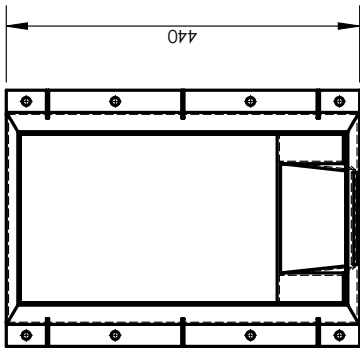
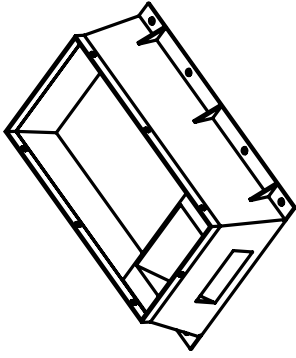

**BANGLADESH RICE RESEARCH INSTITUTE**  
 SFMRA PROJECT, FMPHT DIVISION

DO NOT SCALE DRAWING  
 FINISH: NONE  
 FIRST ISSUED: 17-FEB-2024

**TITLE: BRRI MINI RICE HULLER (BRRI RM2024B)**

**DRG. NAME: BODY BOTTOM CASING**

DWG NO: SFMRA-52.B-028

MANUFACTURING METHOD: MACHINING, BENDING & WELDING

MATERIAL: Plain Carbon Steel

WEIGHT: 5578.10 g

REVISION: A

SHEET 51

SCALE: 1:10

UNLESS OTHERWISE SPECIFIED:  
 STD. TOLERANCE DIMENSIONS ARE IN MILLIMETER  
 MILLIMETER: ±0.1, ANGULAR: ±0.05°  
 \* DOES NOT APPLY TO HOLE SIZE

DETAILS	NAME	SIGNATURE	DATE
DRAWN	ENGR. SHAFER JAHAN KHAN	S J K	28-FEB-2024
CHK'D	DR. MD. MOHAMMAD HOSSAIN	M M H	26-MAR-2024
APP'VD	DR. AKMA SAIFUL ISLAM	A S I	30-APR-2024

THIRD ANGLE PROJECTION:

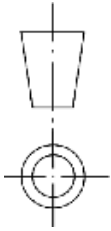

**NOTE:** DEBURR AND BREAK SHARP EDGES ALL BENDS MIN. RADIUS UNLESS SPECIFIED

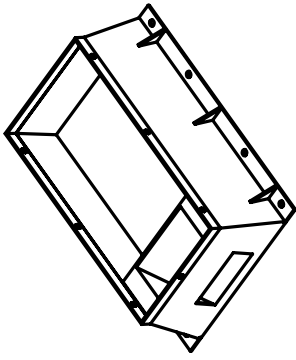

\*MODEL IS SYMMETRY.  
\*SHEET THICKNESS: 3mm.  
\*ONLY FRONT VIEW HAS SHOWN HERE.  
\*SCALE: 1:4

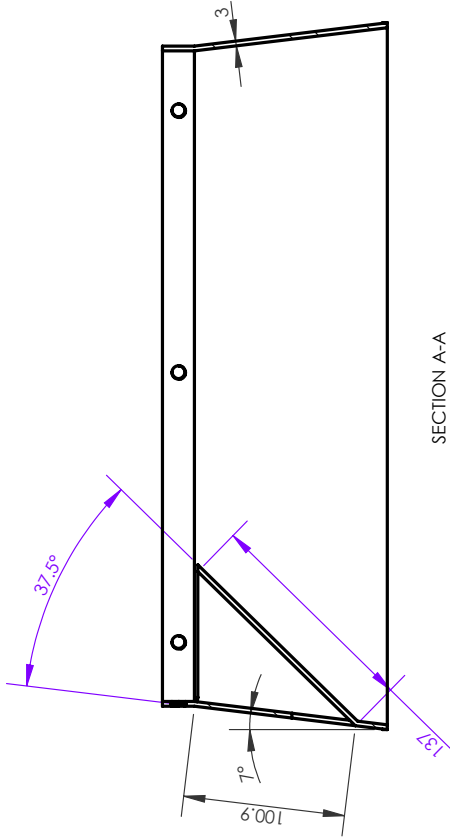
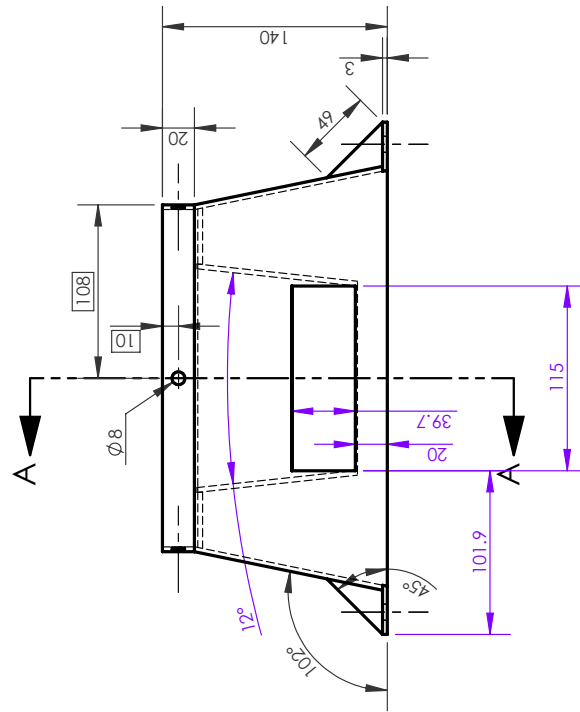

DWG NO: SFMRA-S2.B-028  
SHEET NO: 52

N.B: PURPLE COLOR DIMENSIONS ARE FOR THE CHANNEL LINE.

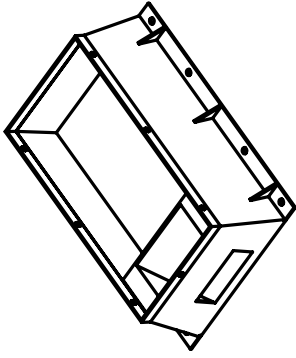

\*MODEL IS SYMMETRY.  
 \*SHEET THICKNESS: 3mm.  
 \*ONLY TOP VIEW HAS SHOWN HERE.  
 \*SCALE: 1:3

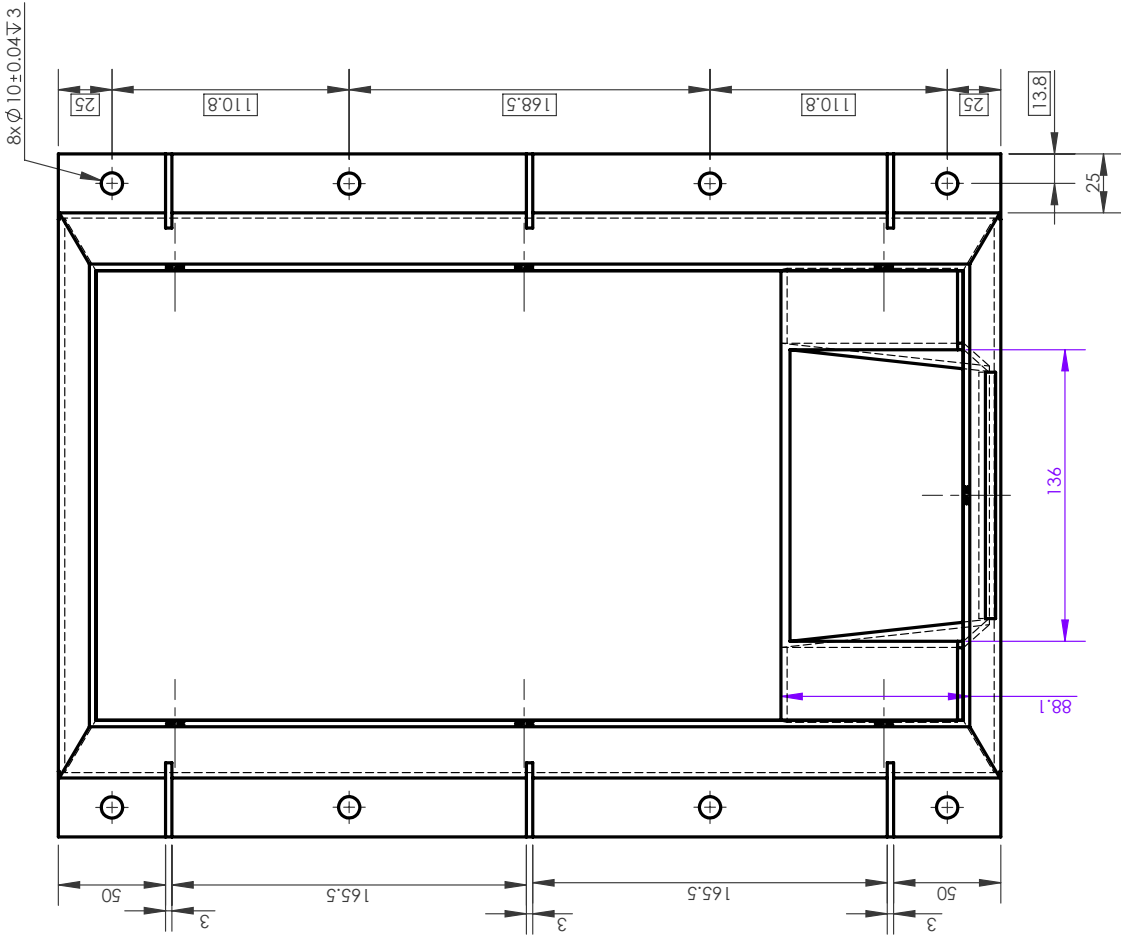

DWG NO: SFMRA-S2.B-028  
 SHEET NO: 53

N.B: PURPLE COLOR DIMENSIONS ARE FOR THE CHANNEL LINE.

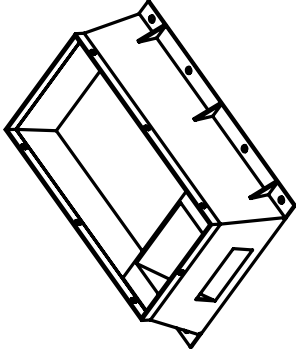

\*MODEL IS SYMMETRY.  
 \*SHEET THICKNESS: 3mm.  
 \*ONLY RIGHT VIEW HAS SHOWN HERE.  
 \*SCALE: 1:3

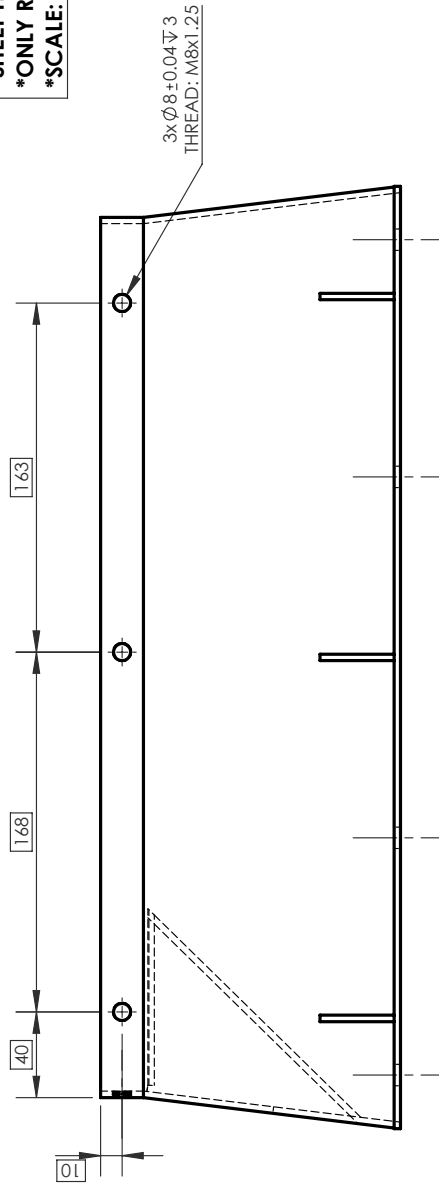

DWG NO: SFMRA-S2.B-028  
 SHEET NO: 54

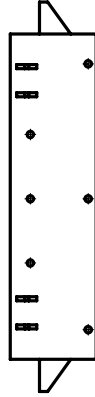
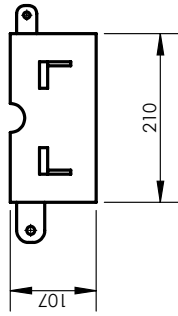
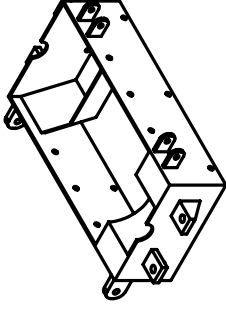
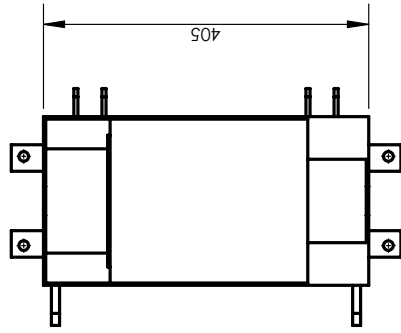

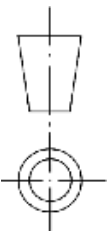
UNLESS OTHERWISE SPECIFIED: STD. TOLERANCE DIMENSIONS ARE IN MILLIMETER MILLIMETER: ±0.1, ANGULAR: ± 0.05° * DOES NOT APPLY TO HOLE SIZE		 <b>BANGLADESH RICE RESEARCH INSTITUTE</b> SFMRA PROJECT, FMPHT DIVISION		DO NOT SCALE DRAWING
DETAILS	NAME	SIGNATURE	DATE	FINISH: NONE
DRAWN	ENGR. SHAHIER JAHAN KHAN	S J K	28-FEB-2024	FIRST ISSUED: 17-FEB-2024
CHK'D	DR. MD. MOSHARRAF HOSSAIN	M M H	26-MAR-2024	
APP'VD	DR. AKMA SAIFUL ISLAM	A S I	30-APR-2024	
THIRD ANGLE PROJECTION: 				
TITLE: BRR I MINI RICE HULLER (BRR RM2024B)				
DRG. NAME: BODY BOTTOM CASING - 2				
DWG NO: SFMRA-S2.B-029				
MANUFACTURING METHOD: MACHINING, BENDING & WELDING				
MATERIAL: Plain Carbon Steel		WEIGHT: 5161.51 g		A4
SCALE: 1:10		SHEET 55		REVISION: A

**NOTE:** DEBURR AND BREAK SHARP EDGES ALL BENDS MIN. RADIUS UNLESS SPECIFIED

\*MODEL IS SYMMETRY.  
 \*SHEET THICKNESS: 3mm.  
 \*ONLY FRONT VIEW HAS SHOWN HERE.  
 \*SCALE: 1:2

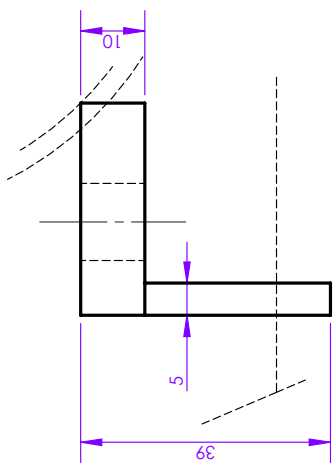
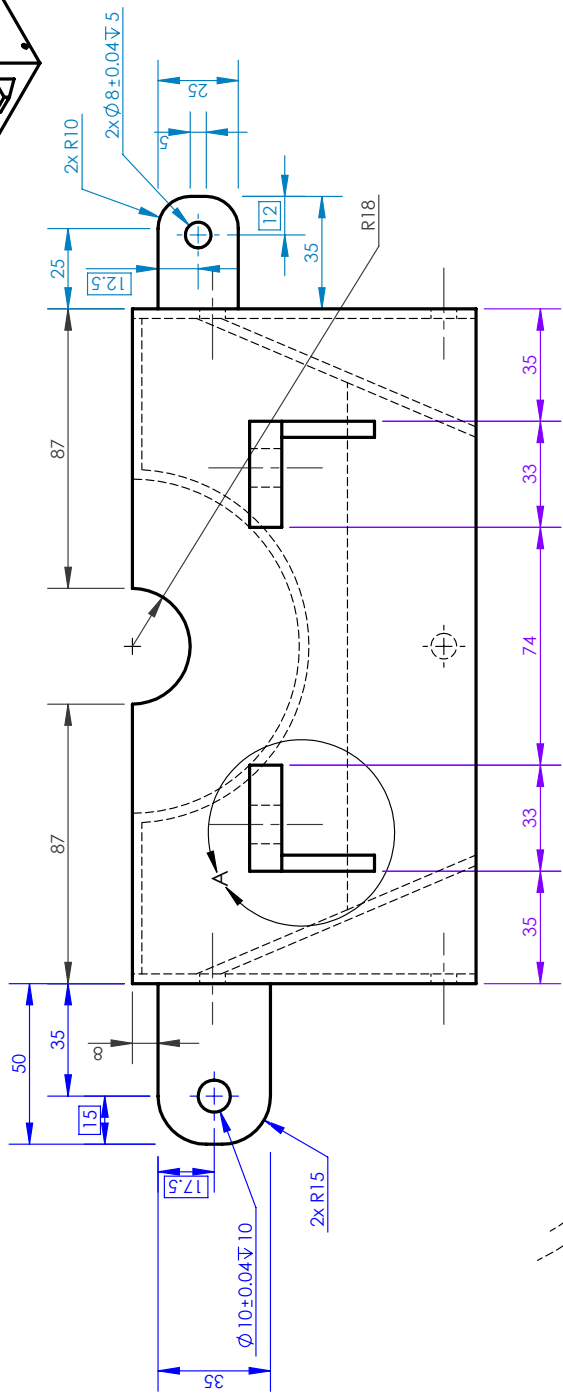
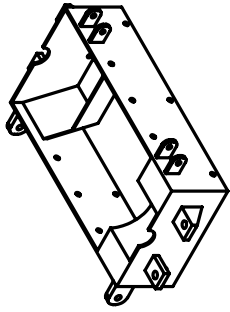

DETAIL A  
 SCALE 1 : 1

\*PURPLE COLOR DIMENSIONS FOR BEARING HOUSING PLACEMENT.  
 \*BLUE COLOR DIMENSIONS FOR DOOR HINGE PLACEMENT.  
 \*LIGHT BLUE COLOR DIMENSIONS FOR DOOR LOCK PLACEMENT.

DRAWING NO: SFMRA -S2.B-029  
 SHEET NO: 56

\*MODEL IS SYMMETRY.  
 \*SHEET THICKNESS: 3mm.  
 \*ONLY RIGHT VIEW HAS SHOWN HERE.  
 \*SCALE: 1:2

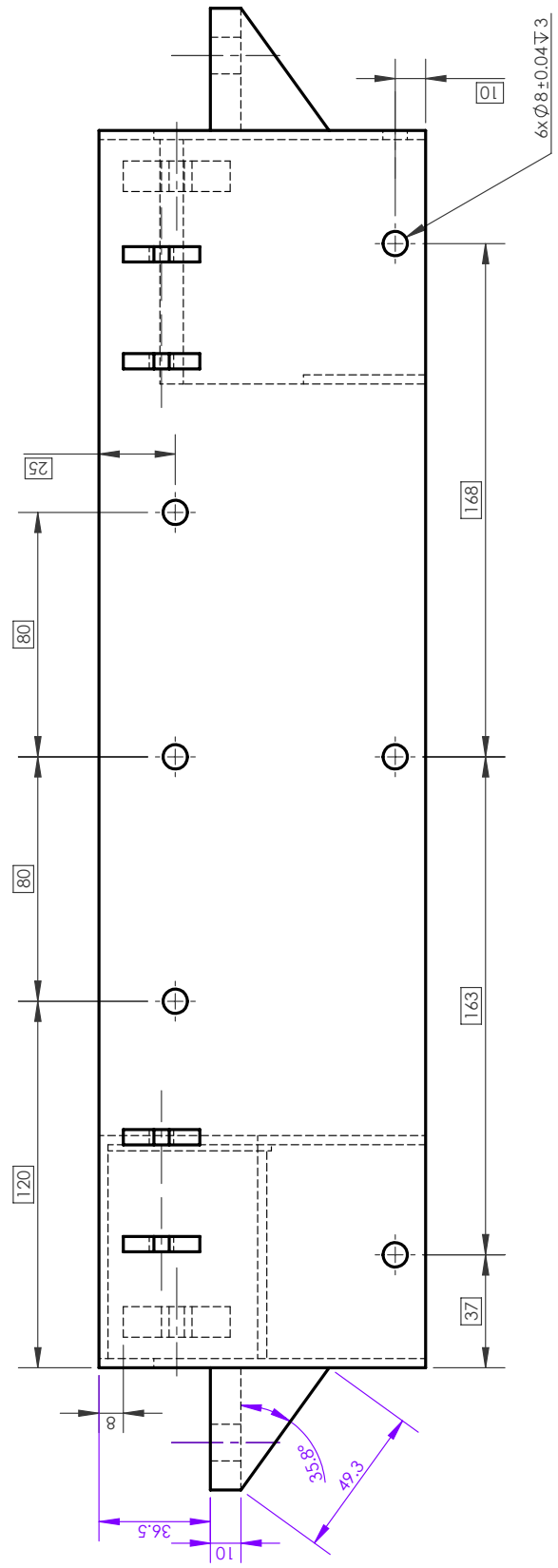
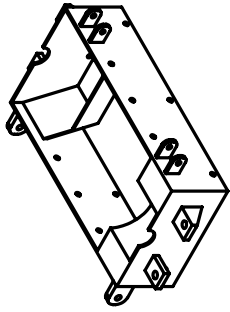

DRAWING NO: SFMRA -S2.B-029  
 SHEET NO: 57

\*PURPLE COLOR DIMENSIONS FOR BEARING HOUSING PLACEMENT.

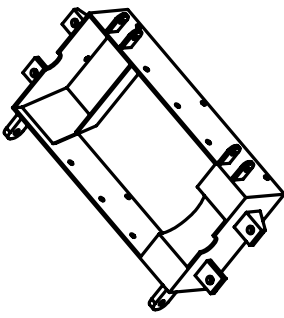

\*MODEL IS SYMMETRY.  
\*SHEET THICKNESS: 3mm.  
\*ONLY TOP VIEW HAS SHOWN HERE.  
\*SCALE: 1:3

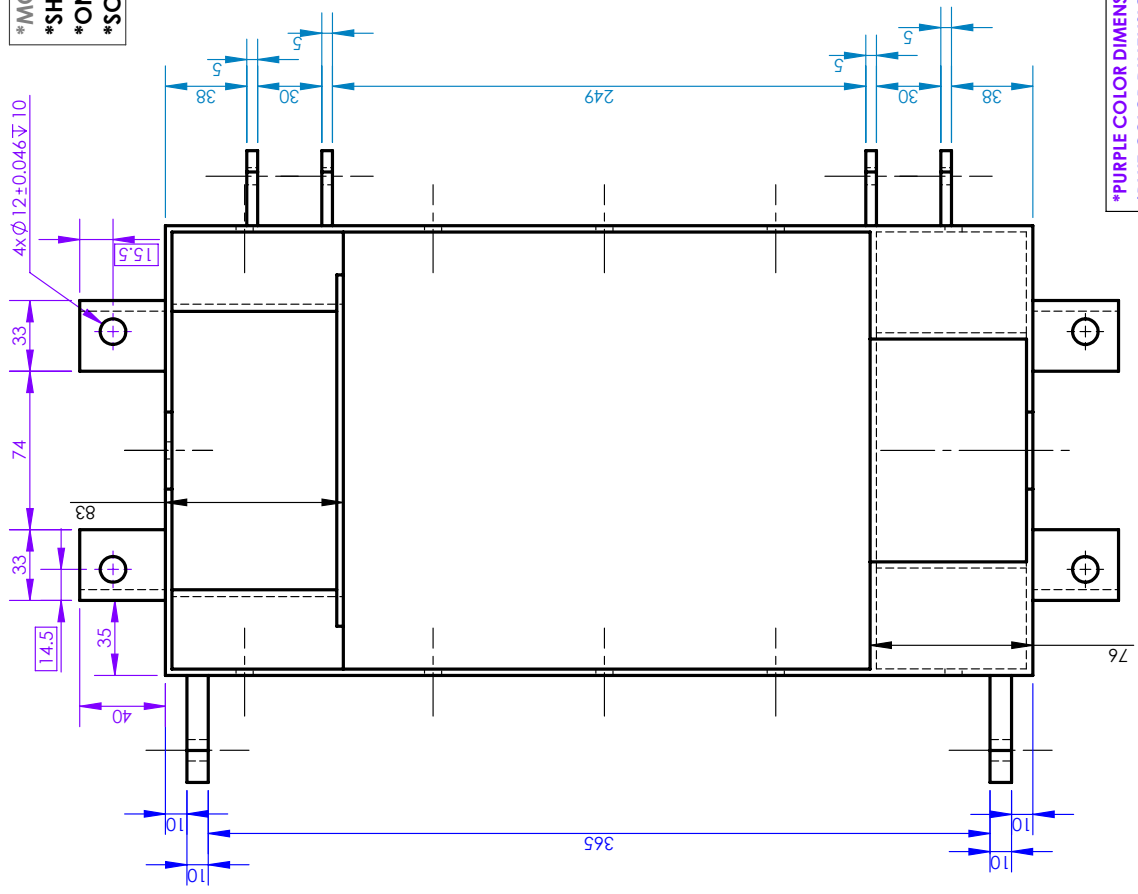

\*PURPLE COLOR DIMENSIONS FOR BEARING HOUSING PLACEMENT.  
\*BLUE COLOR DIMENSIONS FOR DOOR HINGE PLACEMENT.  
\*LIGHT BLUE COLOR DIMENSIONS FOR DOOR LOCK PLACEMENT.

DRAWING NO: SFMRA -S2.B-029  
SHEET NO: 58

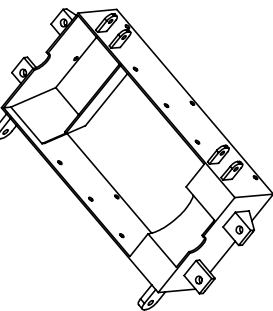

\*MODEL IS SYMMETRY.  
 \*SHEET THICKNESS: 3mm.  
 \*ONLY RIGHT, SECTION B-B AND SECTION C-C FROM  
 RIGHT VIEWS HAS SHOWN HERE.  
 \*SCALE: 1:5

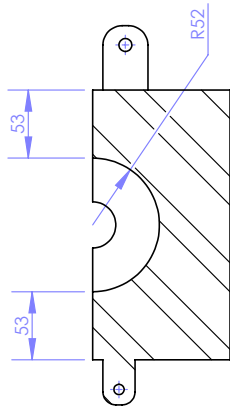

SECTION B-B  
 SCALE 1 : 5

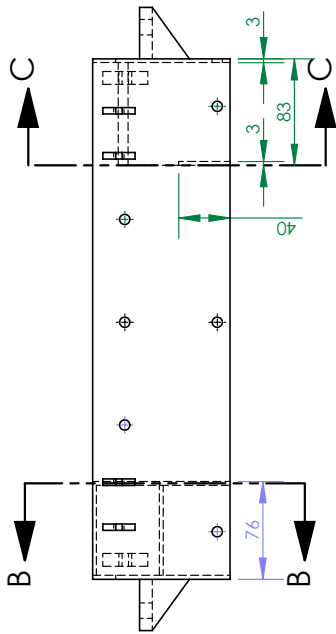

SECTION C-C  
 SCALE 1 : 5

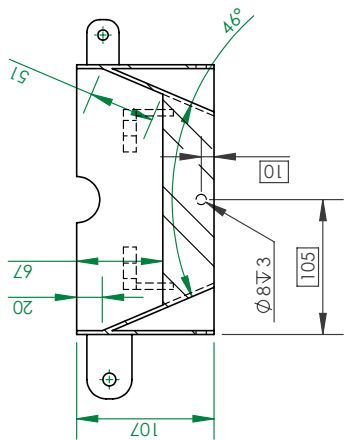

DRAWING NO: SFMRA -S2.B-029  
 SHEET NO: 59

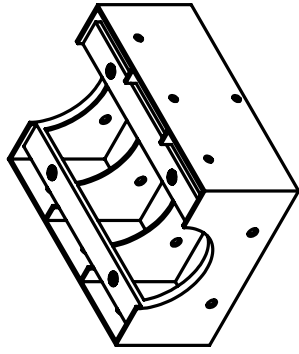

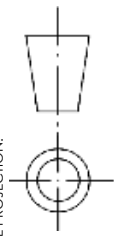
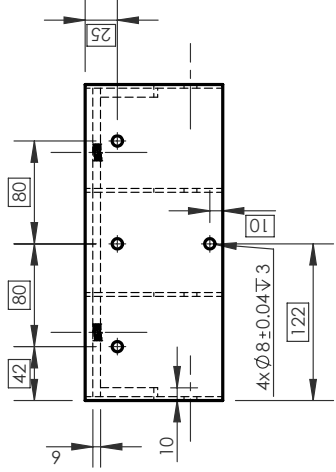
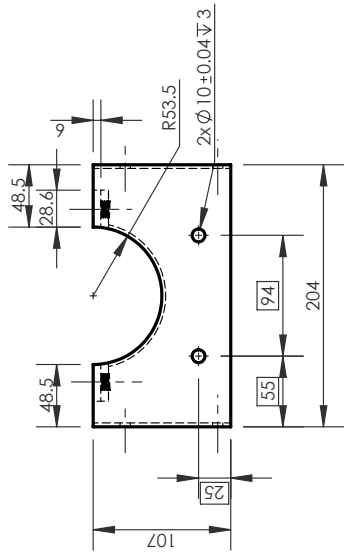
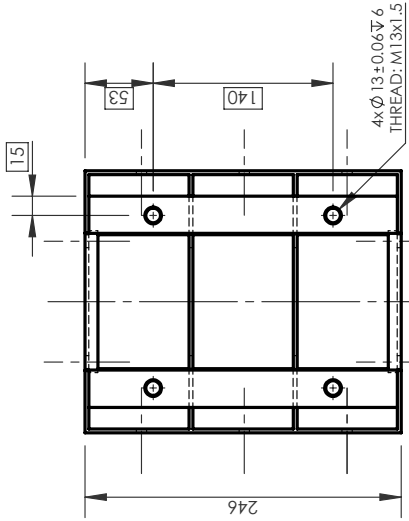

N.B: MODEL IS SYMMETRY.  
 \*SHEET THICKNESS: 3mm.  
 ONLY ONE SIDE DIMENSIONS HAS SHOWN FOR HOLES.

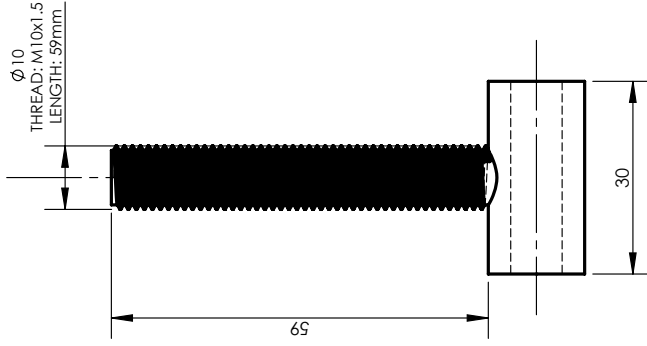
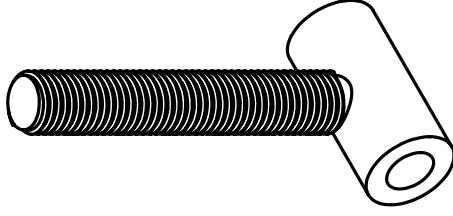

**NOTE:** DEBURR AND BREAK SHARP EDGES ALL BENDS MIN. RADIUS UNLESS SPECIFIED

UNLESS OTHERWISE SPECIFIED: STD. TOLERANCE DIMENSIONS ARE IN MILLIMETER MILLIMETER: ±0.1, ANGULAR: ±0.05° * DOES NOT APPLY TO HOLE SIZE		BANGLADESH RICE RESEARCH INSTITUTE SFMRA PROJECT, FMPHT DIVISION		DO NOT SCALE DRAWING
DETAILS NAME DATE DRAWN ENGR. SHAFIEER JAHAN KHAN S J K 28-FEB-2024 CHK'D DR. MD. MOSHARRAF HOSSAIN M M H 26-MAR-2024 APP'VD DR. AKMA SAIFUL ISLAM A S I 30-APR-2024		TITLE: BRRI MINI RICE HULLER (BRRI RM2024B) DRG. NAME: NET FRAME BOTTOM DWG NO: SFMRA-52.B-030		FINISH: NONE FIRST ISSUED: 17-FEB-2024
THIRD ANGLE PROJECTION:		MANUFACTURING METHOD: MACHINING, BENDING & WELDING MATERIAL: Plain Carbon Steel SCALE: 1:5 SHEET 60		REVISION: A
WEIGHT: 3425.49 g		REVISION: A		A4

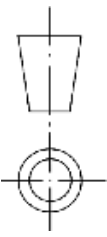

UNLESS OTHERWISE SPECIFIED: STD. TOLERANCE DIMENSIONS ARE IN MILLIMETER MILLIMETER: ±0.1, ANGULAR: ± 0.05° * DOES NOT APPLY TO HOLE SIZE		 <b>BANGLADESH RICE RESEARCH INSTITUTE</b> SFMRA PROJECT, FMPHT DIVISION		DO NOT SCALE DRAWING
DETAILS	NAME	SIGNATURE	DATE	FINISH: NONE
DRAWN	ENGR. SHAFER JAHAN KHAN	S J K	28-FEB-2024	FIRST ISSUED: 17-FEB-2024
CHK'D	DR. MD. MOSHARRAF HOSSAIN	M M H	26-MAR-2024	
APP'VD	DR. AKMAJIBUL ISLAM	A S I	30-APR-2024	
THIRD ANGLE PROJECTION:				
<b>TITLE: BRRI MINI RICE HULLER (BRRI RM2024B)</b> <b>DRG. NAME: CASING LOCK PART - MALE</b> DWG NO: SFMRA-S2.B-031 MANUFACTURING METHOD: MACHINING & WELDING MATERIAL: Plain Carbon Steel SCALE: 1:1 WEIGHT: 59.48 g SHEET 61 REVISION: A				

**NOTE:** DEBURR AND BREAK  
 SHARP EDGES ALL BENDS MIN.  
 RADIUS UNLESS SPECIFIED

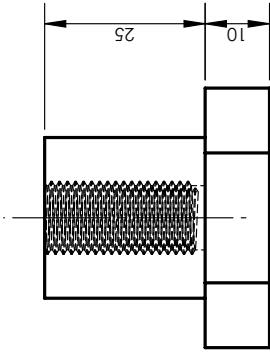
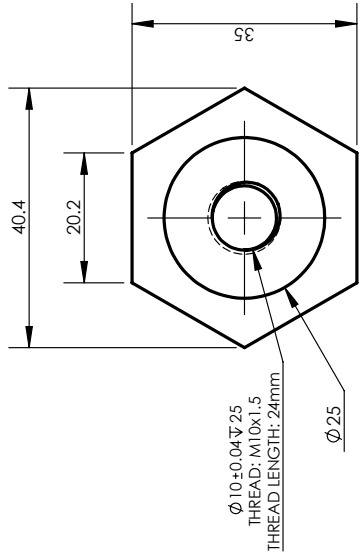
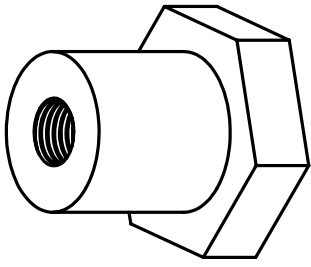

UNLESS OTHERWISE SPECIFIED: STD. TOLERANCE DIMENSIONS ARE IN MILLIMETER MILLIMETER: ±0.1, ANGULAR: ± 0.05° * DOES NOT APPLY TO HOLE SIZE				BANGLADESH RICE RESEARCH INSTITUTE SFMRA PROJECT, FMPHT DIVISION		DO NOT SCALE DRAWING	
DETAILS NAME DRAWN ENGR. SHAFIEE JAHAN KHAN CHK'D DR. MD. MOSHARRAF HOSSAIN APP'VD DR. AKMAJIBUL ISLAM		SIGNATURE S J K M M H A S I		DATE 04-MAR-2024 26-MAR-2024 30-APR-2024		FINISH: NONE FIRST ISSUED: 17-FEB-2024	
TITLE: BRRI MINI RICE HULLER (BRRI RM2024B)				DRG. NAME: CASING LOCK PART - FEMALE			
DWG NO: SFMRA-32.B-032				MANUFACTURING METHOD: MACHINING & WELDING			
MATERIAL: Plain Carbon Steel				WEIGHT: 161.37 g			
SCALE: 1:1				SHEET: 62			
REVISION: A				A4			

**NOTE:** DEBURR AND BREAK  
 SHARP EDGES ALL BENDS MIN.  
 RADIUS UNLESS SPECIFIED

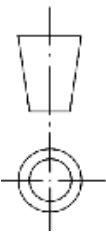

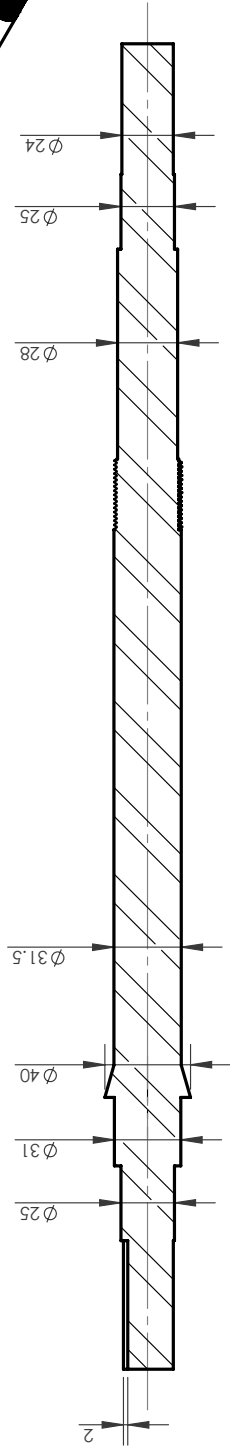
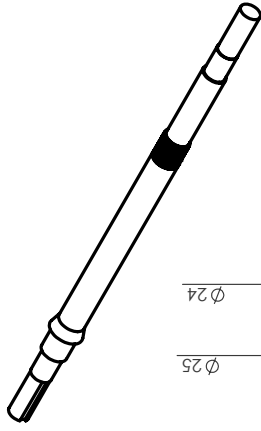

SECTION A-A  
SCALE 1 : 3

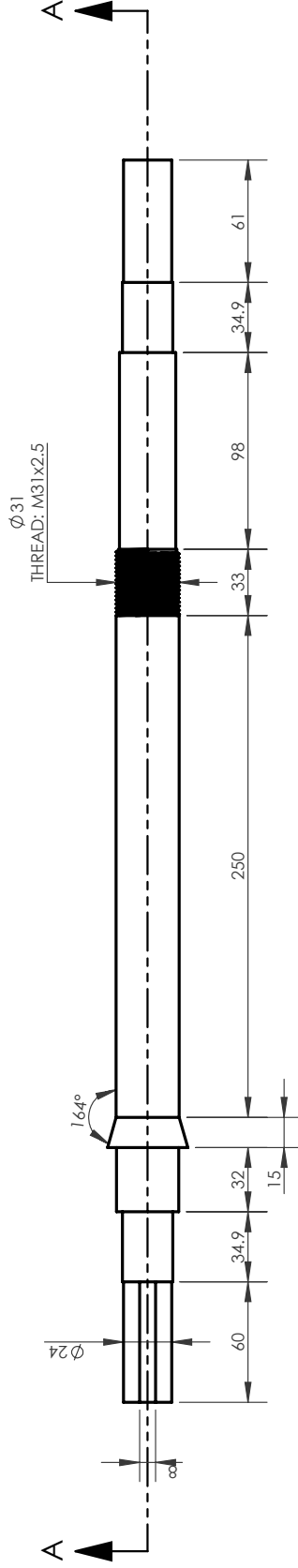

Ø 31  
THREAD: M31x2.5

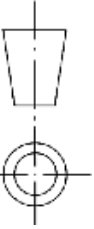
UNLESS OTHERWISE SPECIFIED: STD. TOLERANCE DIMENSIONS ARE IN MILLIMETER MILLIMETER: ±0.1, ANGULAR: ± 0.05° * DOES NOT APPLY TO HOLE SIZE		 <b>BANGLADESH RICE RESEARCH INSTITUTE</b> SFMRA PROJECT, FMPHT DIVISION		DO NOT SCALE DRAWING
DETAILS		SIGNATURE	DATE	FINISH: NONE
DRAWN	ENGR. SHAFER JAHAN KHAN	S J K	04-MAR-2024	FIRST ISSUED: 17-FEB-2024
CHK'D	DR. MD. MOSHARRAF HOSSAIN	M M H	26-MAR-2024	
APP'VD	DR. AKMA SAIFUL ISLAM	A S I	30-APR-2024	
THIRD ANGLE PROJECTION:				
<b>TITLE: BRRI MINI RICE HULLER (BRRI RM2024B)</b> <b>DRG. NAME: HULLER SHELL SHAFT</b> <b>DWG NO: SFMRA-32.B-033</b> <b>MANUFACTURING METHOD: MACHINING</b> <b>MATERIAL: ASTM A36 Steel</b> <b>SCALE: 1:5</b>				
WEIGHT: 3183.19 g			REVISION: A	
SHEET 63			A4	

**NOTE:** DEBURR AND BREAK  
SHARP EDGES ALL BENDS MIN.  
RADIUS UNLESS SPECIFIED

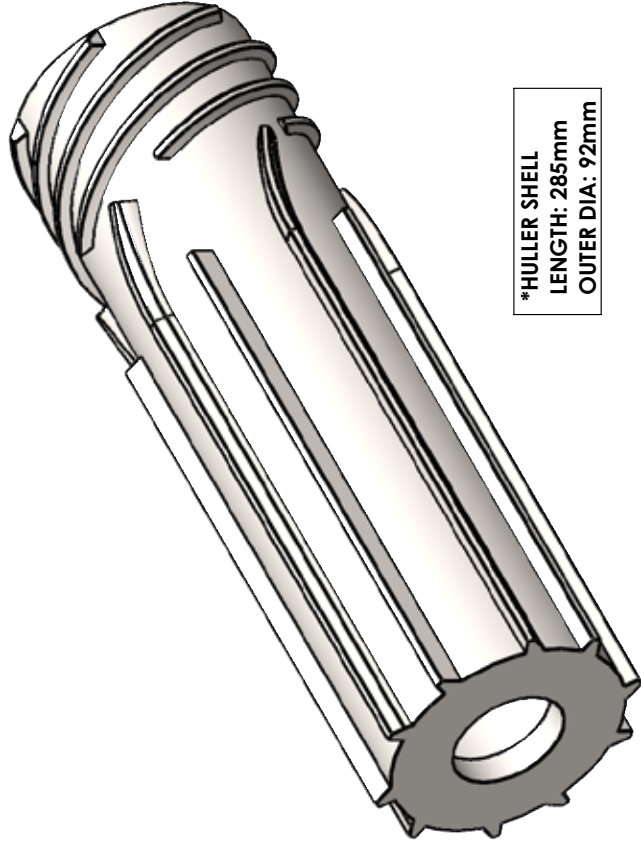

**\*HULLER SHELL  
LENGTH: 285mm  
OUTER DIA: 92mm**

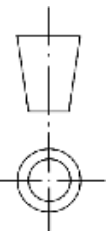
UNLESS OTHERWISE SPECIFIED: STD. TOLERANCE DIMENSIONS ARE IN MILLIMETER MILLIMETER: ±0.1, ANGULAR: ± 0.05° * DOES NOT APPLY TO HOLE SIZE				<b>BANGLADESH RICE RESEARCH INSTITUTE</b> SFMRA PROJECT, FMPHT DIVISION		DO NOT SCALE DRAWING	
DETAILS		NAME	SIGNATURE	DATE	FINISH: NONE		
DRAWN		ENGR. SHAFER JAHAN KHAN	S J K	04-MAR-2024	FIRST ISSUED: 17-FEB-2024		
CHK'D		DR. MD. MOSHARRAF HOSSAIN	M M H	26-MAR-2024	TITLE: BRRI MINI RICE HULLER (BRRI RM2024B)		
APP'VD		DR. AKMASAIFUL ISLAM	A S I	30-APR-2024	DRG. NAME: HULLER SHELL		
THIRD ANGLE PROJECTION:				DWG NO: SFMRA-S2.B-034			WEIGHT: 5688.91 g
NOTE: DEBURR AND BREAK SHARP EDGES ALL BENDS MIN. RADIUS UNLESS SPECIFIED		OUTSOURCING: VENDOR		SCALE: 1:5			REVISION: A
		MATERIAL: Plain Carbon Steel		SHEET 64			A4

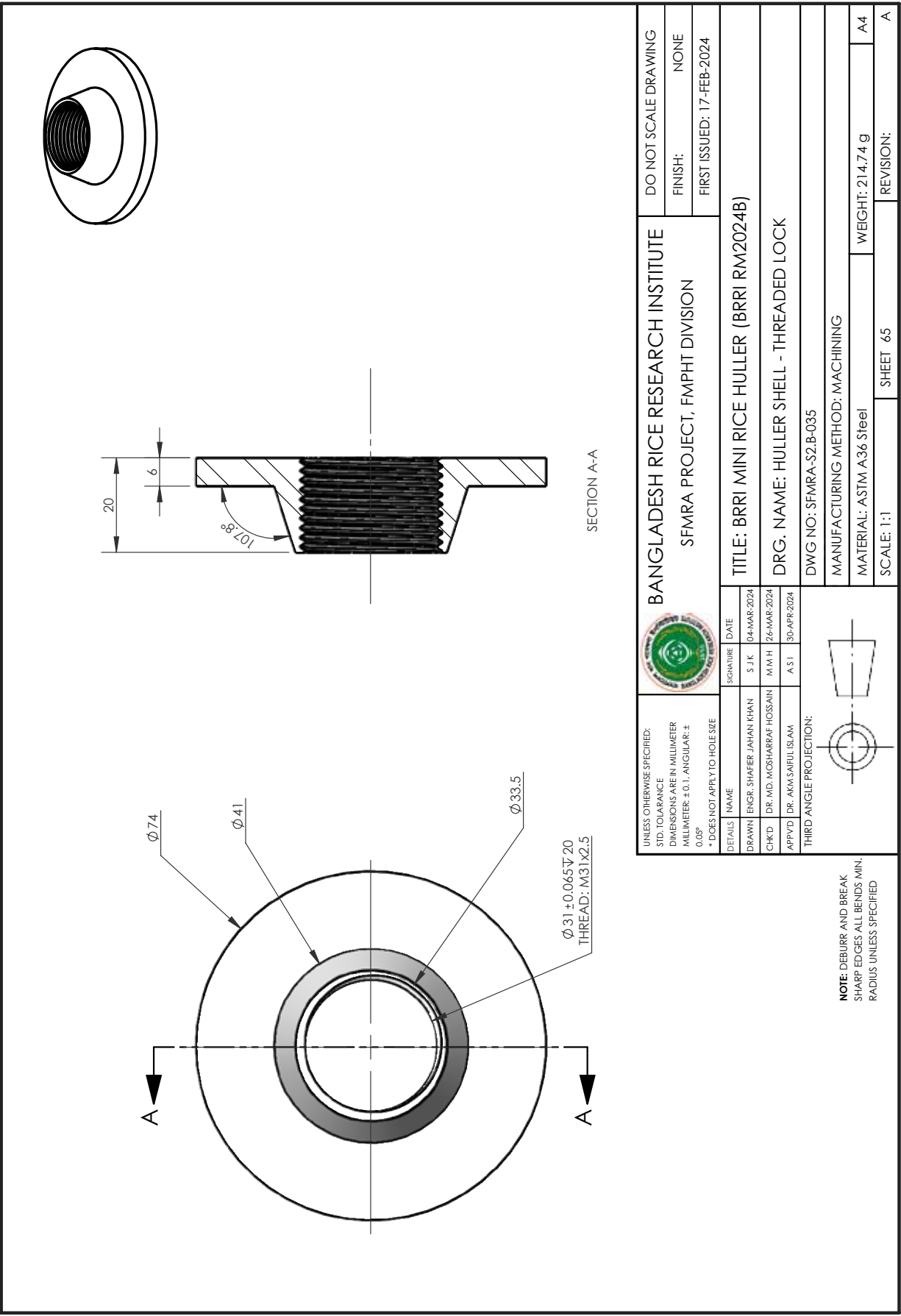

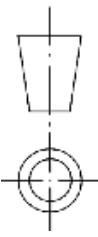
UNLESS OTHERWISE SPECIFIED: STD. TOLERANCE DIMENSIONS ARE IN MILLIMETER MILLIMETER: ±0.1, ANGULAR: ± 0.05° * DOES NOT APPLY TO HOLE SIZE				<b>BANGLADESH RICE RESEARCH INSTITUTE</b> SFMRA PROJECT, FMPHT DIVISION		DO NOT SCALE DRAWING	
DETAILS		NAME	SIGNATURE	DATE	FINISH: NONE		
DRAWN		ENGR. SHAFER JAHAN KHAN	S J K	04-MAR-2024	FIRST ISSUED: 17-FEB-2024		
CHK'D		DR. MD. MOSHARRAF HOSSAIN	M M H	26-MAR-2024	TITLE: BRRI MINI RICE HULLER (BRRI RM2024B)		
APP'VD		DR. AKMA SAIFUL ISLAM	A S I	30-APR-2024	DRG. NAME: HULLER SHELL - THREADED LOCK		
THIRD ANGLE PROJECTION:				DWG NO: SFMRA-52.B-035			
NOTE: DEBURR AND BREAK SHARP EDGES ALL BENDS MIN. RADIUS UNLESS SPECIFIED				MANUFACTURING METHOD: MACHINING			
				MATERIAL: ASTM A36 Steel		WEIGHT: 214.74 g	
				SCALE: 1:1		REVISION: A	
				SHEET 65		A4	

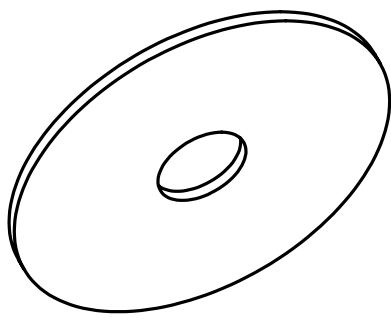

**WASHER**  
**OUTER DIA: 128 mm**  
**INNER DIA: 30mm**  
**THICKNESS: 4mm**  
**QUANTITY: 01**

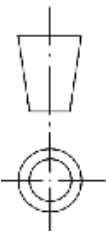
UNLESS OTHERWISE SPECIFIED: STD. TOLERANCE DIMENSIONS ARE IN MILLIMETER MILLIMETER: ±0.1, ANGULAR: ± 0.05° * DOES NOT APPLY TO HOLE SIZE		 <b>BANGLADESH RICE RESEARCH INSTITUTE</b> SFMRA PROJECT, FMPHT DIVISION		DO NOT SCALE DRAWING
DETAILS	NAME	SIGNATURE	DATE	FINISH: NONE
DRAWN	ENGR. SHAFER JAHAN KHAN	S J K	04-MAR-2024	FIRST ISSUED: 17-FEB-2024
CHK'D	DR. MD. MOSHARRAF HOSSAIN	M M H	26-MAR-2024	
APP'VD	DR. AKMAJIBUL ISLAM	A S I	30-APR-2024	
THIRD ANGLE PROJECTION:				
				
TITLE: BRRI MINI RICE HULLER (BRRI RM2024B) DRG. NAME: WASHER - 1 DWG NO: SFMRA-S2.B-036 OUTSOURCING: VENDOR MATERIAL: Plain Carbon Steel SCALE: 1:2 SHEET 66				WEIGHT: 379.43 g
				REVISION: A

**NOTE:** DEBURR AND BREAK  
 SHARP EDGES ALL BENDS MIN.  
 RADIUS UNLESS SPECIFIED

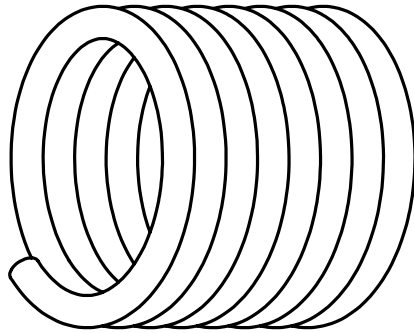

MAIN CIRCLE DIA: 45mm  
 PITCH: 6mm  
 REVOLUTION: 8  
 SPRING CIRCLE DIA: 5mm  
 FULL LENGTH: 54mm

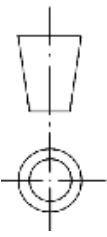
UNLESS OTHERWISE SPECIFIED: STD. TOLERANCE DIMENSIONS ARE IN MILLIMETER MILLIMETER: ±0.1, ANGULAR: ± 0.05° * DOES NOT APPLY TO HOLE SIZE				<b>BANGLADESH RICE RESEARCH INSTITUTE</b> SFMRA PROJECT, FMPHT DIVISION		DO NOT SCALE DRAWING	
DETAILS	NAME	SIGNATURE	DATE	TITLE: BRRI MINI RICE HULLER (BRRI RM2024B)			
DRAWN	ENGR. SHAFER JAHAN KHAN	S J K	04-MAR-2024	DRG. NAME: SPRING			
CHK'D	DR. MD. MOSHARRAF HOSSAIN	M M H	26-MAR-2024	DWG NO: SFMRA-S2.B-037			
APP'VD	DR. AKMA SAIFUL ISLAM	A S I	30-APR-2024	OUTSOURCING: VENDOR			
THIRD ANGLE PROJECTION:				MATERIAL: Plain Carbon Steel			
				WEIGHT: 173.35 g			
				SCALE: 1:1			
				SHEET 67			
				REVISION: A			

**NOTE:** DEBURR AND BREAK  
 SHARP EDGES ALL BENDS MIN.  
 RADIUS UNLESS SPECIFIED

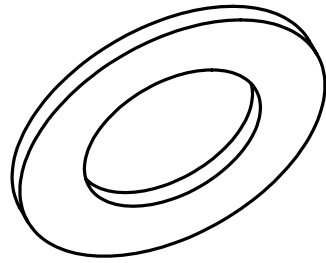

**WASHER**  
**OUTER DIA: 52mm**  
**INNER DIA: 30mm**  
**THICKNESS: 4mm**  
**QUANTITY: 01**

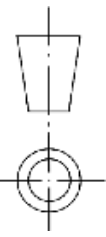
UNLESS OTHERWISE SPECIFIED: STD. TOLERANCE DIMENSIONS ARE IN MILLIMETER MILLIMETER: ±0.1, ANGULAR: ± 0.05° * DOES NOT APPLY TO HOLE SIZE		 <b>BANGLADESH RICE RESEARCH INSTITUTE</b> SFMRA PROJECT, FMPHT DIVISION		DO NOT SCALE DRAWING
DETAILS		SIGNATURE	DATE	FINISH: NONE
DRWN	ENGR. SHAFER JAHAN KHAN	S J K	04-MAR-2024	FIRST ISSUED: 17-FEB-2024
CHK'D	DR. MD. MOSHARRAF HOSSAIN	M M H	26-MAR-2024	
APP'VD	DR. AKMA SAIFUL ISLAM	A S I	30-APR-2024	
THIRD ANGLE PROJECTION:				
TITLE: BRR I MINI RICE HULLER (BRR I RM2024B)		DRG. NAME: WASHER - 2		
DWG NO: SFMRA-S2.B-038		OUTSOURCING: VENDOR		
MATERIAL: Plain Carbon Steel		SCALE: 1:1		
WEIGHT: 33.15 g		SHEET: 68		
REVISION: A		A4		

**NOTE:** DEBURR AND BREAK  
 SHARP EDGES ALL BENDS MIN.  
 RADIUS UNLESS SPECIFIED



BEARING HOUSING: UCP-205  
 QUANTITY: 02

UNLESS OTHERWISE SPECIFIED: STD. TOLERANCE DIMENSIONS ARE IN MILLIMETER MILLIMETER: ±0.1, ANGULAR: ± 0.05° * DOES NOT APPLY TO HOLE SIZE				<b>BANGLADESH RICE RESEARCH INSTITUTE</b> SFMRA PROJECT, FMPHT DIVISION		DO NOT SCALE DRAWING	
DETAILS		NAME	SIGNATURE	DATE	TITLE: BRRI MINI RICE HULLER (BRRI RM2024B)		
DRWN	ENGR. SHAFER JAHAN KHAN	S J K		04-MAR-2024	DRG. NAME: UCP-205		
CHK'D	DR. MD. MOSHARRAF HOSSAIN	M M H		26-MAR-2024	DWG NO: SFMRA-S2.B-038		
APP'VD	DR. AKMAJILUL ISLAM	A S I		30-APR-2024	OUTSOURCING: VENDOR		
THIRD ANGLE PROJECTION:							
MATERIAL: N/A		SCALE: 1:2		SHEET 69		REVISION: A	
WEIGHT: N/A g		A4					

**NOTE:** DEBURR AND BREAK  
 SHARP EDGES ALL BENDS MIN.  
 RADIUS UNLESS SPECIFIED

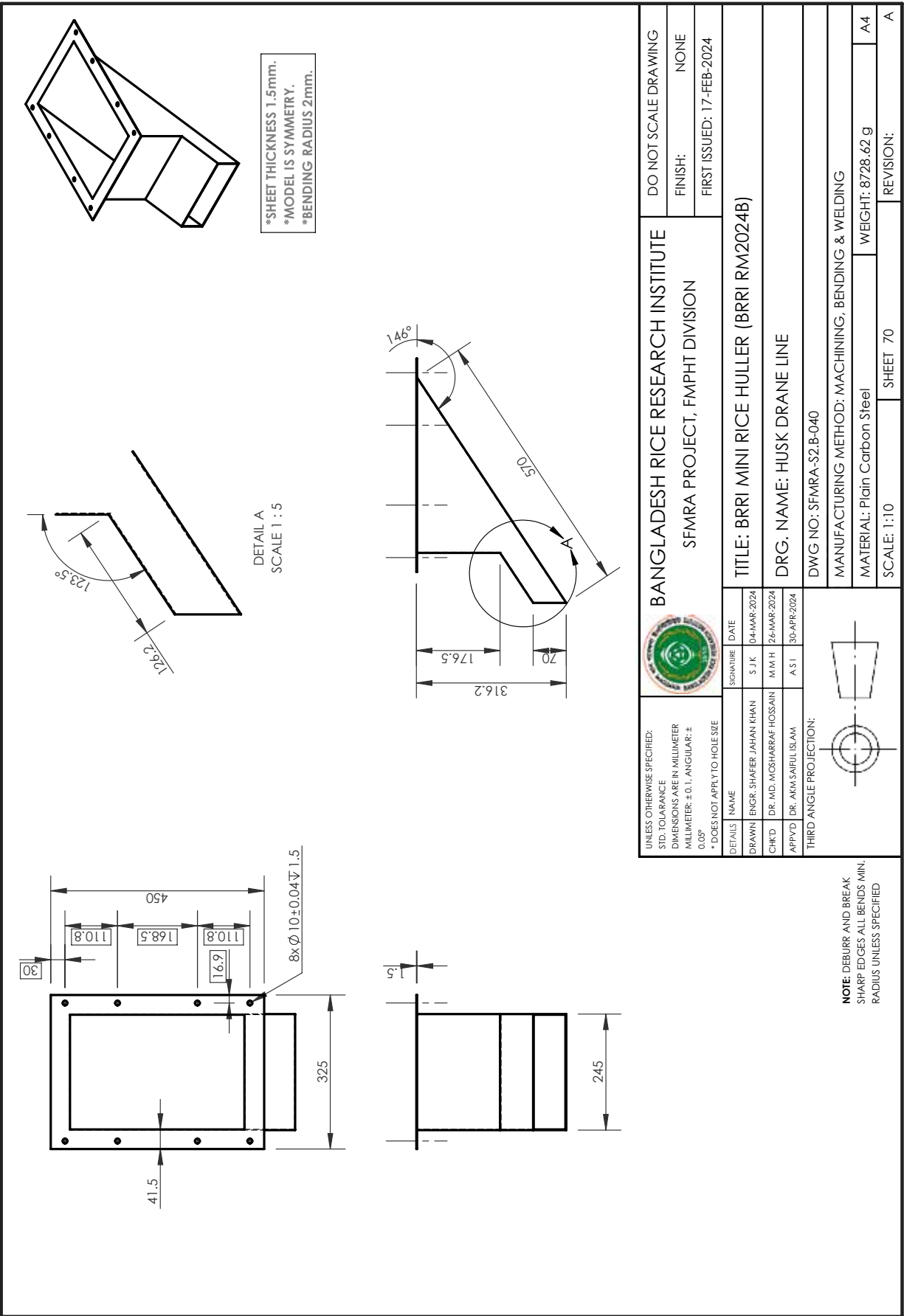

		<b>BANGLADESH RICE RESEARCH INSTITUTE</b> SFMRA PROJECT, FMPHT DIVISION		DO NOT SCALE DRAWING
TITLE: BRR MINI RICE HULLER (BRRM2024B)		DRG. NAME: HUSK DRANE LINE		FINISH: NONE
DWG NO: SFMRA-S2.B-040		MANUFACTURING METHOD: MACHINING, BENDING & WELDING		FIRST ISSUED: 17-FEB-2024
MATERIAL: Plain Carbon Steel		SCALE: 1:10		REVISION: A
WEIGHT: 8728.62 g		SHEET 70		A4

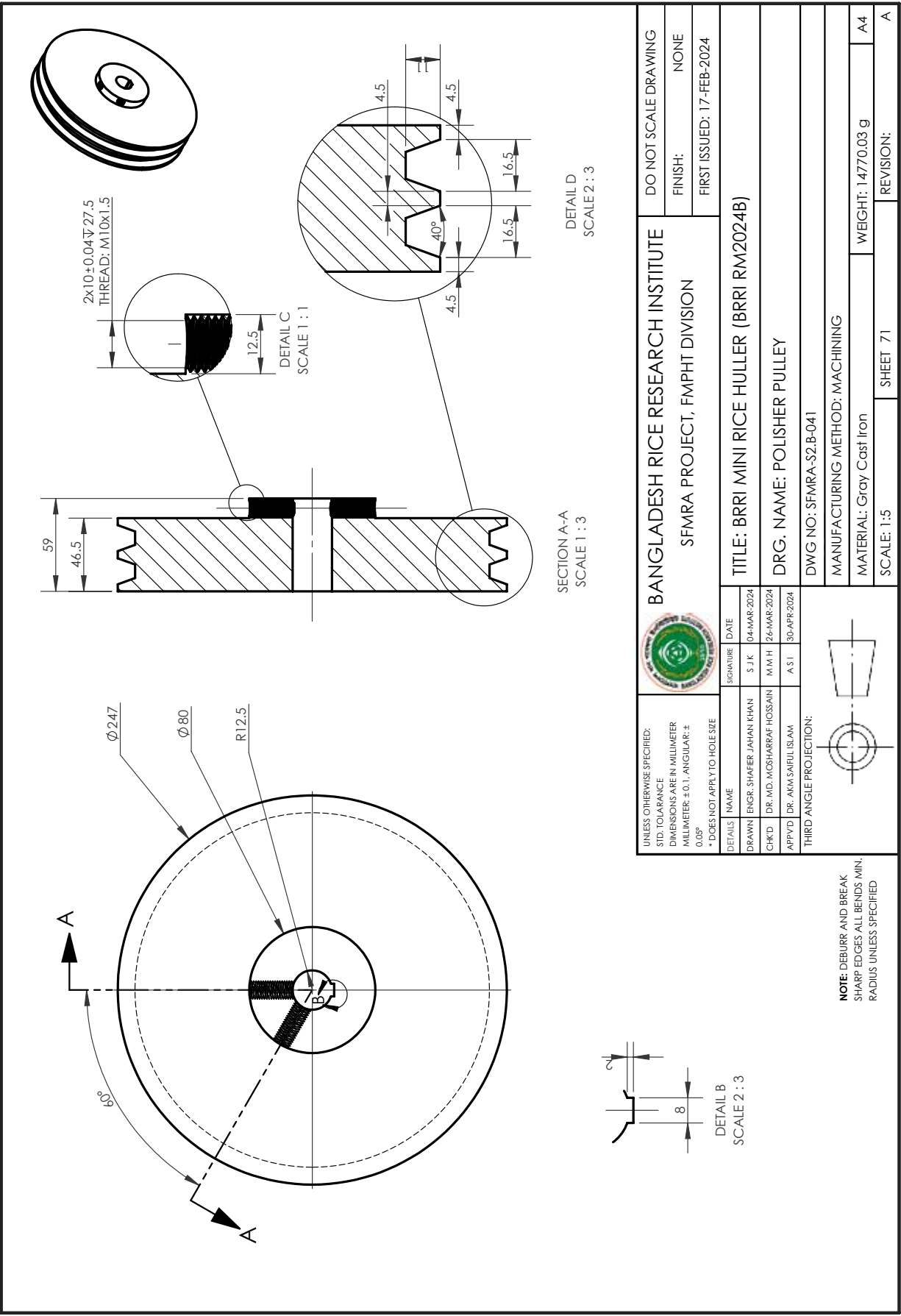

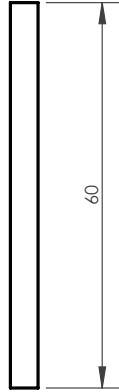
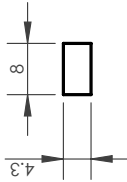
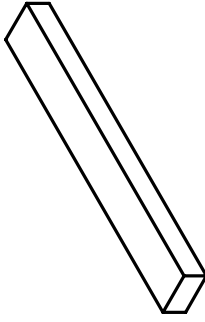

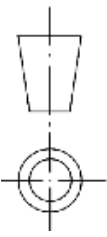
UNLESS OTHERWISE SPECIFIED: STD. TOLERANCE DIMENSIONS ARE IN MILLIMETER MILLIMETER: ±0.1, ANGULAR: ± 0.05° * DOES NOT APPLY TO HOLE SIZE				BANGLADESH RICE RESEARCH INSTITUTE SFMRA PROJECT, FMPHT DIVISION		DO NOT SCALE DRAWING	
DETAILS	NAME	SIGNATURE	DATE	TITLE: BRRI MINI RICE HULLER (BRRI RM2024B)		FINISH:	NONE
DRAWN	ENGR. SHAFER JAHAN KHAN	S J K	04-MAR-2024	DRG. NAME: SHAFT SLOT KEY		FIRST ISSUED: 17-FEB-2024	
CHK'D	DR. MD. MOSHARRAF HOSSAIN	M M H	26-MAR-2024	DWG NO: SFMRA-S2.B-042			
APP'VD	DR. AKMA SAIFUL ISLAM	A S I	30-APR-2024	MANUFACTURING METHOD: MACHINING			
THIRD ANGLE PROJECTION:						MATERIAL: Plain Carbon Steel	
				SCALE: 1:1		WEIGHT: 16.10 g	
				SHEET 72		REVISION: A	

**NOTE:** DEBURR AND BREAK SHARP EDGES ALL BENDS MIN. RADIUS UNLESS SPECIFIED

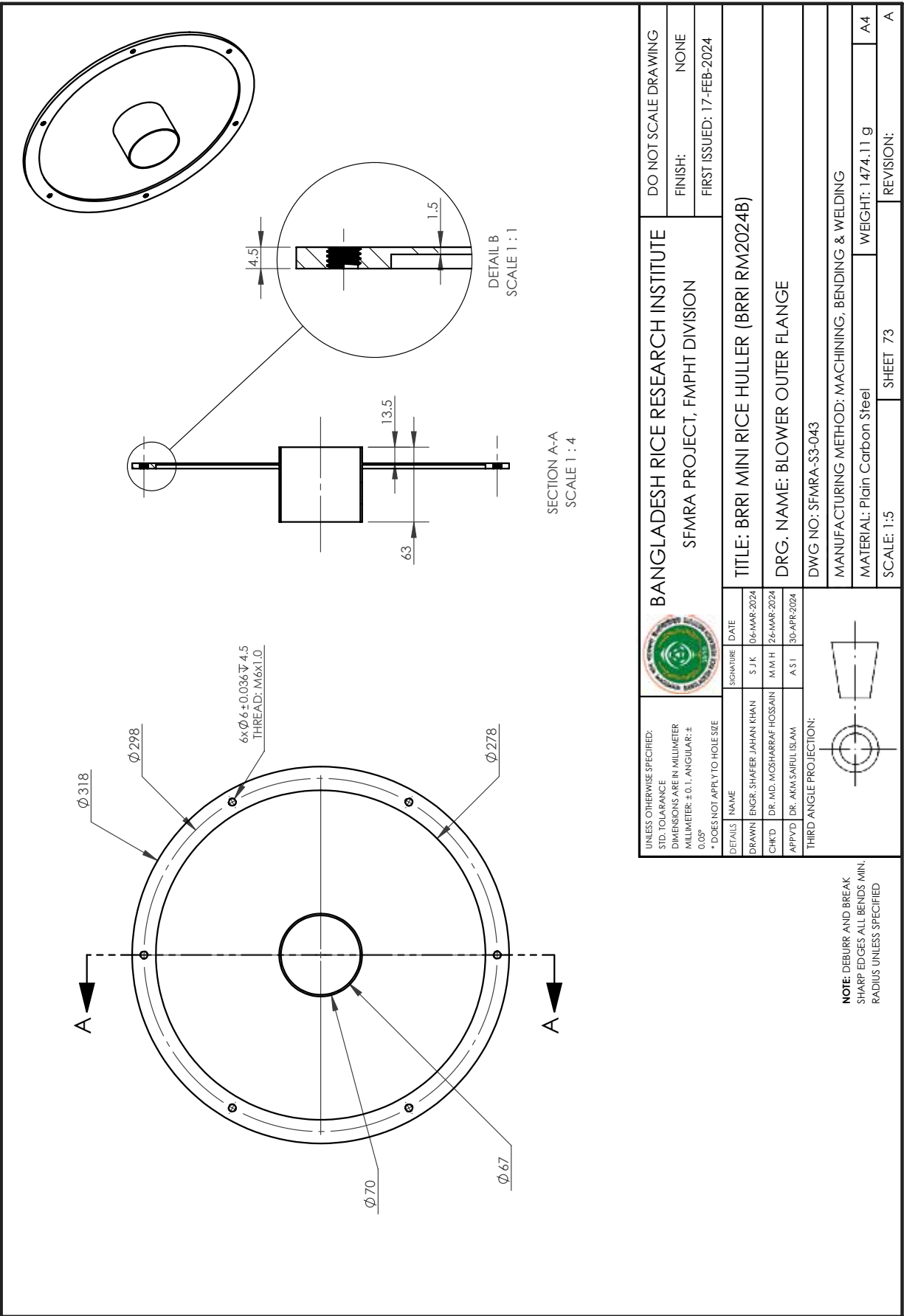

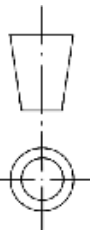
UNLESS OTHERWISE SPECIFIED: STD. TOLERANCE DIMENSIONS ARE IN MILLIMETER MILLIMETER: ±0.1, ANGULAR: ± 0.05° * DOES NOT APPLY TO HOLE SIZE				<b>BANGLADESH RICE RESEARCH INSTITUTE</b> SFMRA PROJECT, FMPHT DIVISION		DO NOT SCALE DRAWING	
DETAILS		NAME	SIGNATURE	DATE	FINISH: NONE		FIRST ISSUED: 17-FEB-2024
DRAWN	ENGR. SHAFER JAHAN KHAN	S J K	06-MAR-2024	TITLE: BRRI MINI RICE HULLER (BRRI RM2024B)			
CHK'D	DR. MD. MOSHARRAF HOSSAIN	M M H	26-MAR-2024	DRG. NAME: BLOWER OUTER FLANGE			
APP'VD	DR. AKMA SAIFUL ISLAM	A S I	30-APR-2024	DWG NO: SFMRA-S3-043			
THIRD ANGLE PROJECTION:							
MANUFACTURING METHOD: MACHINING, BENDING & WELDING							
MATERIAL: Plain Carbon Steel				WEIGHT: 1474.11 g			
SCALE: 1:5				SHEET 73		REVISION: A	

**NOTE:** DEBURR AND BREAK SHARP EDGES ALL BENDS MIN. RADIUS UNLESS SPECIFIED

UNLESS OTHERWISE SPECIFIED:  
 STD. TOLERANCE DIMENSIONS ARE IN MILLIMETER  
 MILLIMETER: ±0.1, ANGULAR: ±0.05°  
 \* DOES NOT APPLY TO HOLE SIZE

DETAILS	NAME	SIGNATURE	DATE
DRAWN	ENGR. SHAFER JAHAN KHAN	S J K	06-MAR-2024
CHK'D	DR. MD. MOSHARRAF HOSSAIN	M M H	26-MAR-2024
APP'VD	DR. AKMA SAIFUL ISLAM	A S I	30-APR-2024

THIRD ANGLE PROJECTION:

**NOTE:** DEBURR AND BREAK SHARP EDGES ALL BENDS MIN. RADIUS UNLESS SPECIFIED

**BANGLADESH RICE RESEARCH INSTITUTE**  
 SFMRA PROJECT, FMPHT DIVISION

**TITLE: BRRI MINI RICE HULLER (BRRI RM2024B)**  
 DRG. NAME: CYCLONE  
 DWG NO: SFMRA-53-044  
 MANUFACTURING METHOD: MACHINING, BENDING & WELDING  
 MATERIAL: Plain Carbon Steel  
 SCALE: 1:10  
 SHEET 74

DO NOT SCALE DRAWING  
 FINISH: NONE  
 FIRST ISSUED: 17-FEB-2024

WEIGHT: 8294.77 g  
 REVISION: A

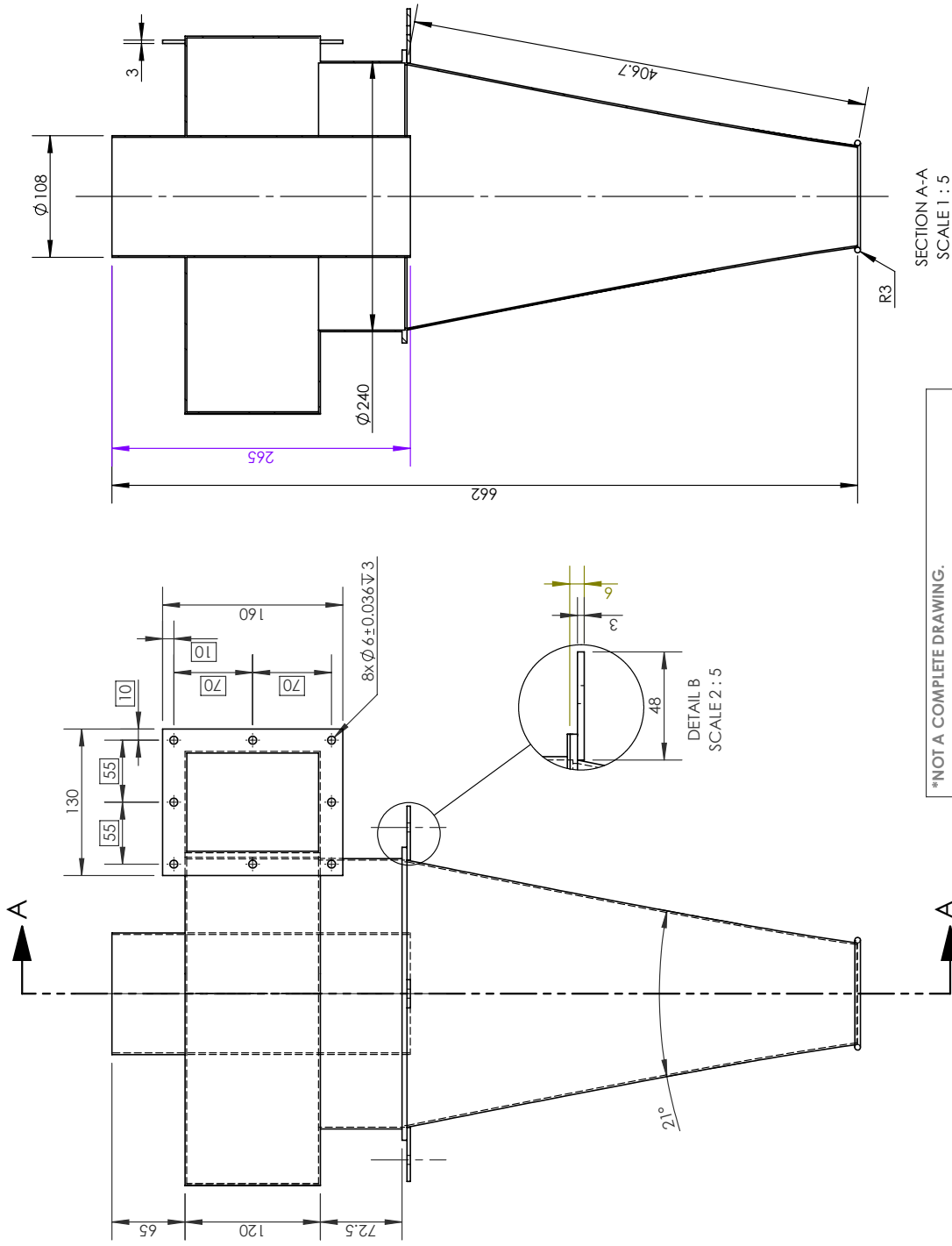
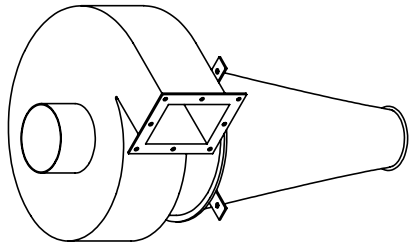

\*NOT A COMPLETE DRAWING.  
 \*ONLY FRONT VIEW DIMENSIONS HAS SHOWN HERE.  
 \*SHEET THICKNESS 1.5mm.  
 \*SCALE 1:5

DWG NO: SFMRA-S3-044  
 SHEET NO: 75

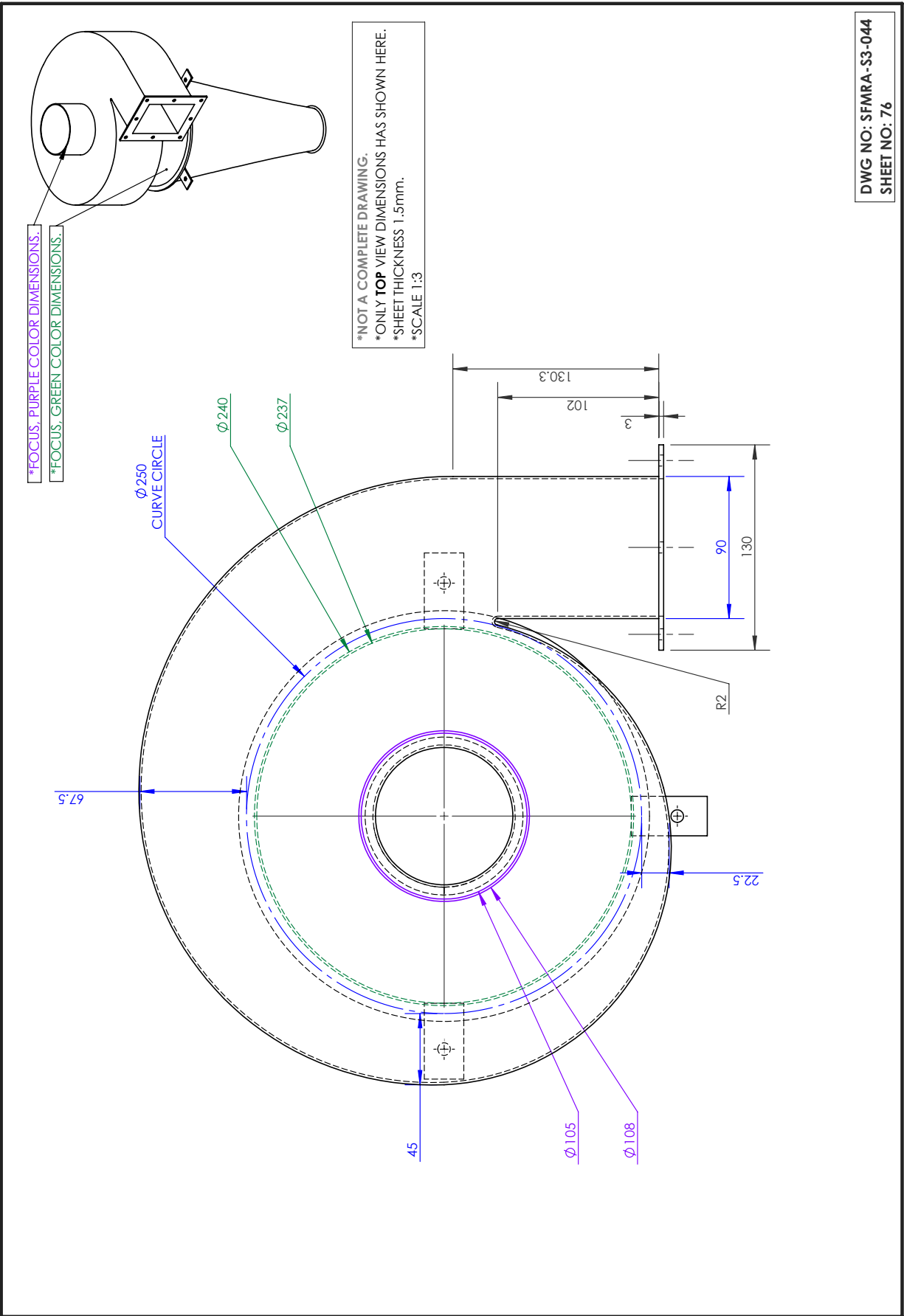

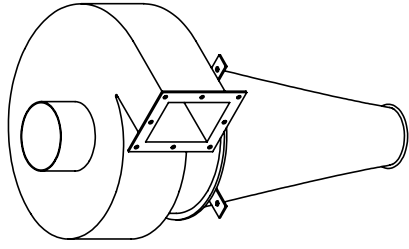

\*NOT A COMPLETE DRAWING.  
 \*ONLY **RIGHT VIEW** DIMENSIONS HAS SHOWN HERE.  
 \*SHEET THICKNESS 1.5mm.  
 \*SCALE 1:7

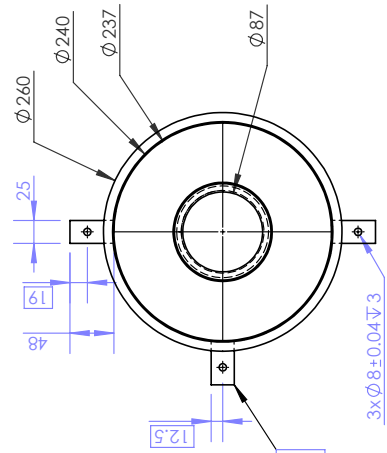
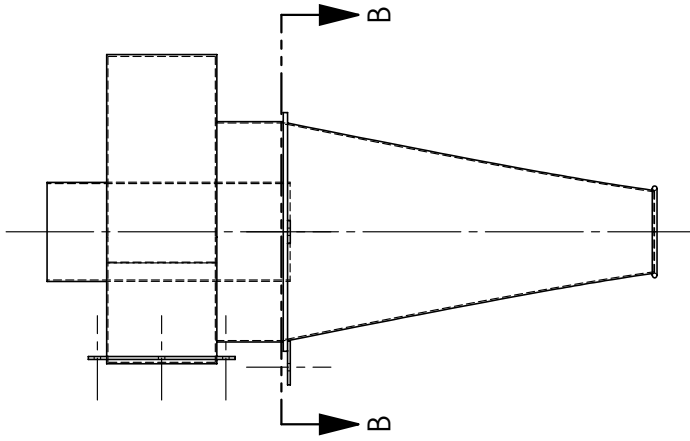

N.B: TOTAL 3 PART WILL BE WELDED HERE.  
 \*EQUAL DISTANCES.

SECTION B-B  
 SCALE 1 : 7

DWG NO: SFMRA-S3-044  
 SHEET NO: 77

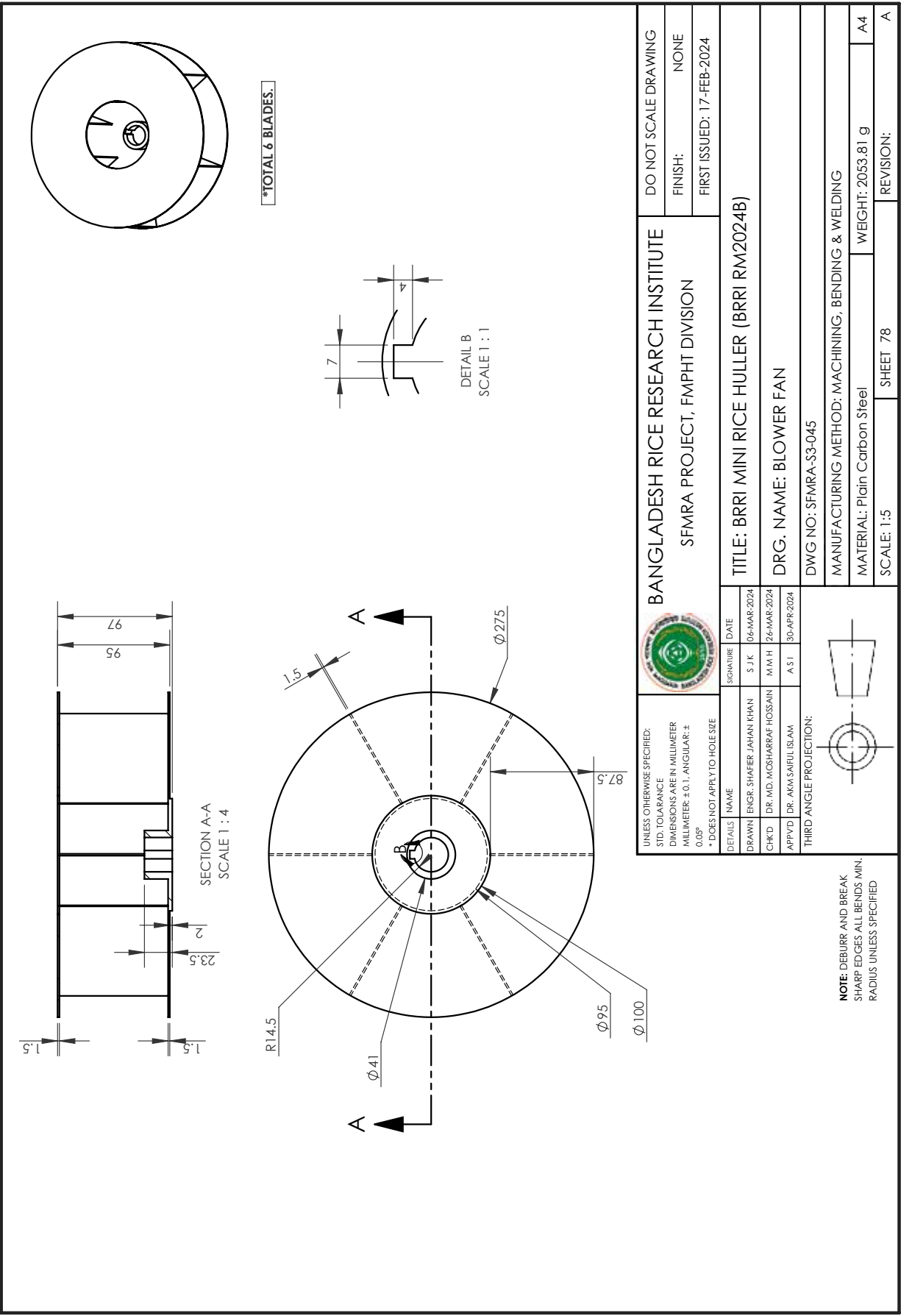

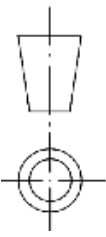
		<b>BANGLADESH RICE RESEARCH INSTITUTE</b> SFMRA PROJECT, FMPHT DIVISION		DO NOT SCALE DRAWING
UNLESS OTHERWISE SPECIFIED: STD. TOLERANCE DIMENSIONS ARE IN MILLIMETER MILLIMETER: ±0.1, ANGULAR: ±0.05° * DOES NOT APPLY TO HOLE SIZE		CHKD: DR. MD. MOSHARRAF HOSSAIN APPVD: DR. AKMASAIFUL ISLAM	DRAWN: ENGR. SHAFIEER JAHAN KHAN DATE: 06-MAR-2024	FINISH: NONE
DETAILS NAME: DR. MD. MOSHARRAF HOSSAIN DATE: 26-MAR-2024		TITLE: <b>BRR I MINI RICE HULLER (BRR I RM2024B)</b>		FIRST ISSUED: 17-FEB-2024
THIRD ANGLE PROJECTION: 		DRG. NAME: <b>BLOWER FAN</b>		
		DWG NO: SFMRA-S3-045		
		MANUFACTURING METHOD: MACHINING, BENDING & WELDING		
		MATERIAL: Plain Carbon Steel		
		SCALE: 1:5		
		WEIGHT: 2053.81 g		
		SHEET 78		
		REVISION:		A

**NOTE:** DEBURR AND BREAK SHARP EDGES ALL BENDS MIN. RADIUS UNLESS SPECIFIED

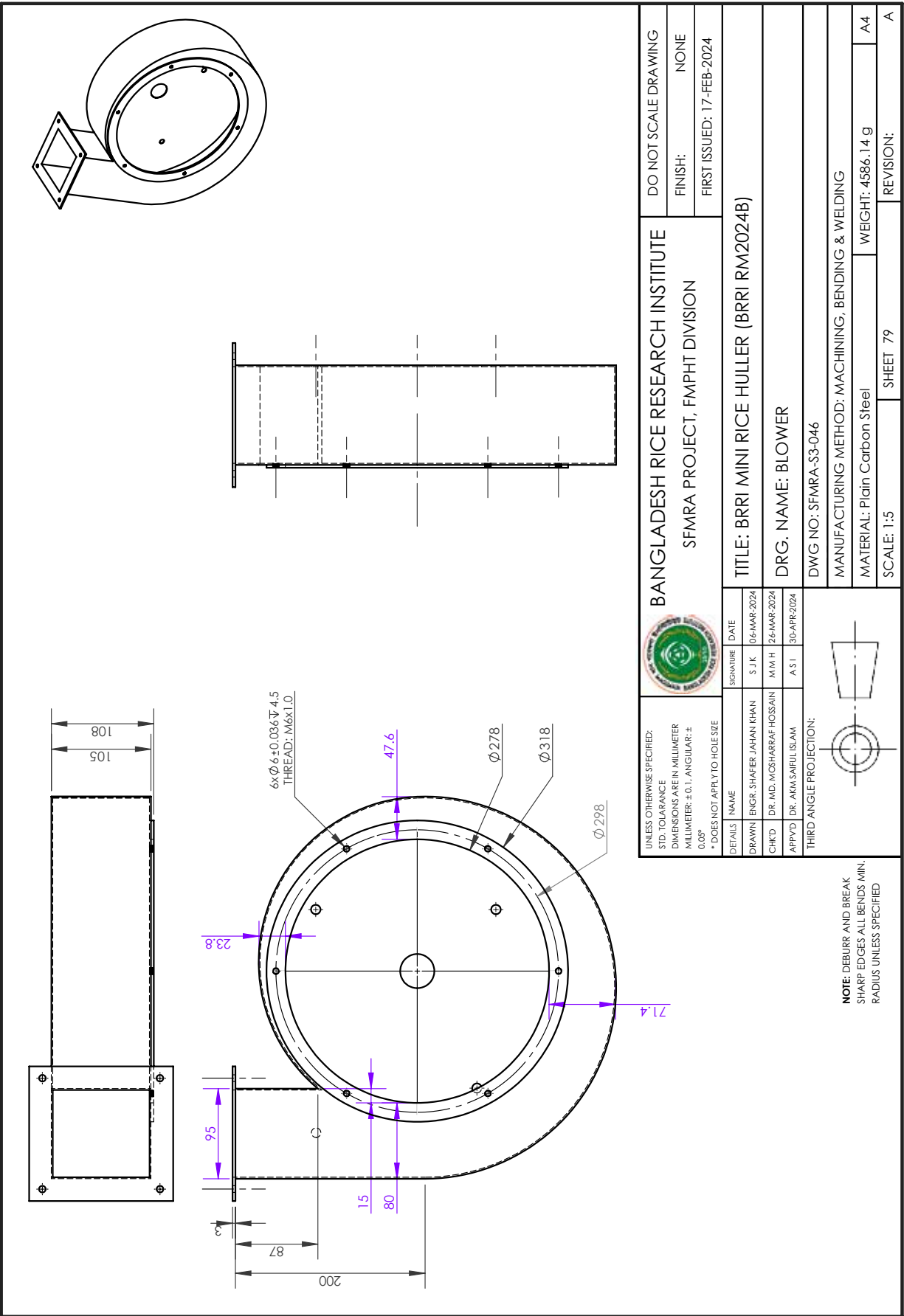

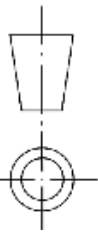
UNLESS OTHERWISE SPECIFIED: STD. TOLERANCE DIMENSIONS ARE IN MILLIMETER MILLIMETER: ±0.1, ANGULAR: ± 0.05° * DOES NOT APPLY TO HOLE SIZE				<b>BANGLADESH RICE RESEARCH INSTITUTE</b> SFMRA PROJECT, FMPHT DIVISION		DO NOT SCALE DRAWING	
DETAILS	NAME	SIGNATURE	DATE			FINISH: NONE	
DRAWN	ENGR. SHAFER JAHAN KHAN	S JK	06-MAR-2024			FIRST ISSUED: 17-FEB-2024	
CHK'D	DR. MD. MOSHARRAF HOSSAIN	M M H	26-MAR-2024				
APP'VD	DR. AKMA SAIFUL ISLAM	A S I	30-APR-2024				
THIRD ANGLE PROJECTION:							
				<b>TITLE: BRR I MINI RICE HULLER (BRR I RM2024B)</b>			
				<b>DRG. NAME: BLOWER</b>			
				DWG NO: SFMRA-S3-046			
				MANUFACTURING METHOD: MACHINING, BENDING & WELDING			
				MATERIAL: Plain Carbon Steel		WEIGHT: 4586.14 g	
				SCALE: 1:5		SHEET 79	
						REVISION: A	

**NOTE:** DEBURR AND BREAK SHARP EDGES ALL BENDS MIN. RADIUS UNLESS SPECIFIED

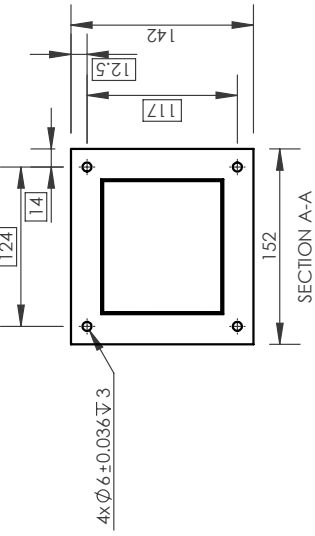

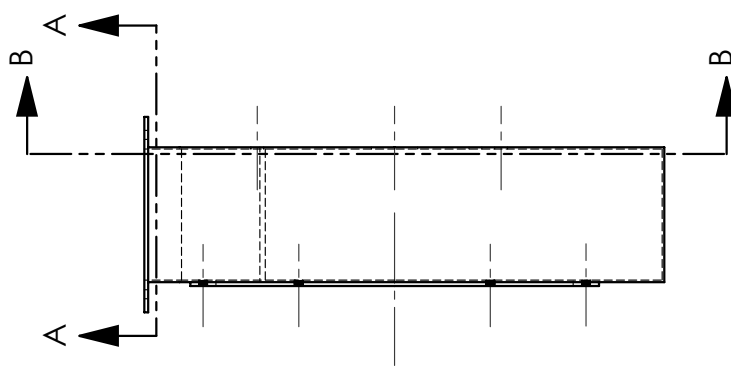
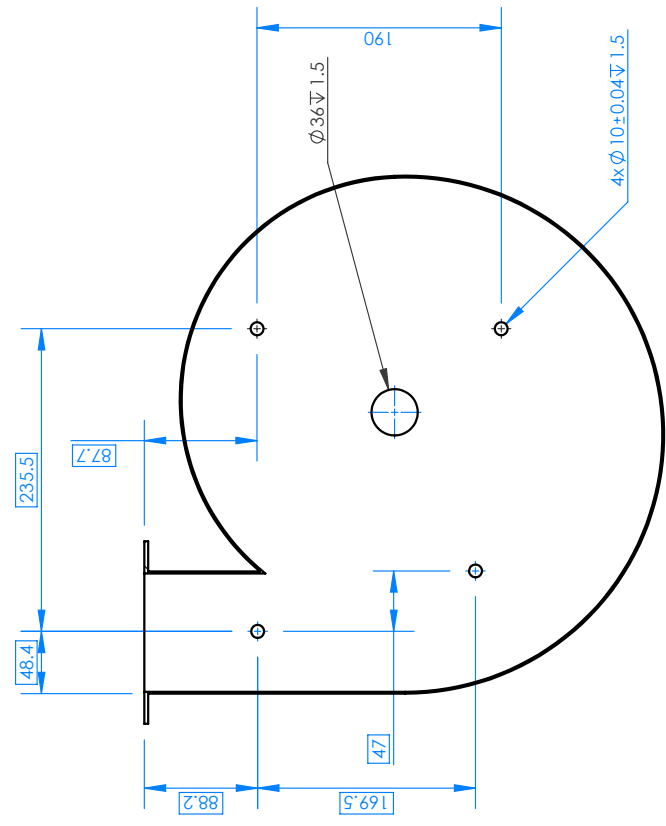
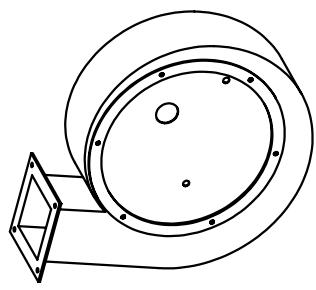

N.B: MODEL IS SYMMETRY FOR HOLES.  
 \*NOT A COMPLETE DRAWING.  
 \*ONLY **RIGHT VIEW** AND **SECTION FROM THE RIGHT VIEW**  
 DIMENSIONS HAS SHOWN IN THIS SHEET.  
 \*SHEET THICKNESS: 1.5mm  
 \*SCALE 1:5

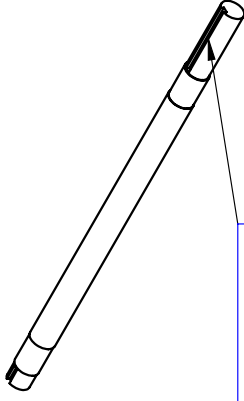



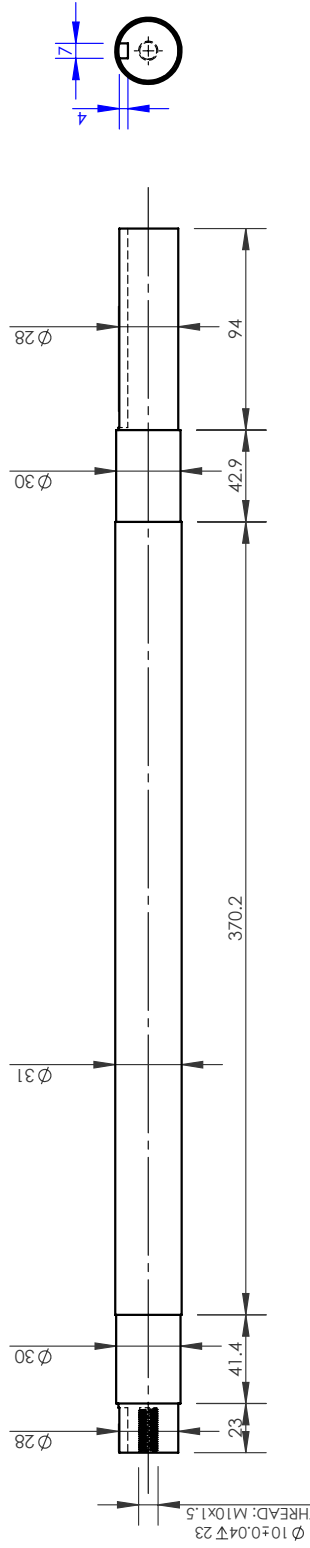

N.B BLUE COLOR DIMENSIONS FOR KEY SLOTS. 2 SLOTS SAME SIZE.

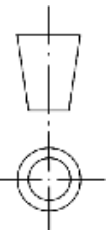

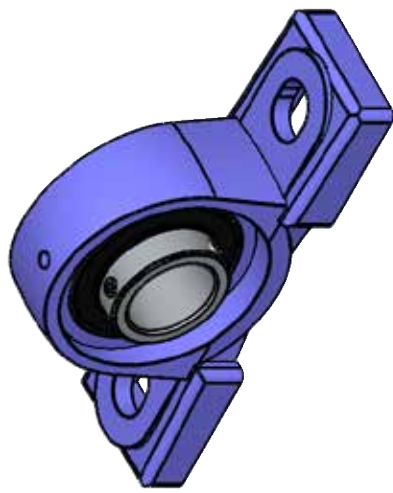
UNLESS OTHERWISE SPECIFIED: STD. TOLERANCE DIMENSIONS ARE IN MILLIMETER MILLIMETER: ±0.1, ANGULAR: ± 0.05° * DOES NOT APPLY TO HOLE SIZE				<b>BANGLADESH RICE RESEARCH INSTITUTE</b> SFMRA PROJECT, FMPHT DIVISION		DO NOT SCALE DRAWING	
DETAILS	NAME	SIGNATURE	DATE	<b>TITLE: BRRI MINI RICE HULLER (BRRI RM2024B)</b>		FINISH: NONE	
DRAWN	ENGR. SHAFIEE JAHAN KHAN	S J K	06-MAR-2024	<b>DRG. NAME: BLOWER SHAFT</b>		FIRST ISSUED: 17-FEB-2024	
CHK'D	DR. MD. MOSHARRAF HOSSAIN	M M H	26-MAR-2024	<b>DWG NO: SFMRA-S3-047</b>			
APP'VD	DR. AKMA SAIFUL ISLAM	A S I	30-APR-2024	<b>MANUFACTURING METHOD: MACHINING</b>			
THIRD ANGLE PROJECTION:							
<b>NOTE: DEBURR AND BREAK SHARP EDGES ALL BENDS MIN. RADIUS UNLESS SPECIFIED</b>				<b>MATERIAL: Plain Carbon Steel</b>		<b>WEIGHT: 3170.69 g</b>	
				<b>SCALE: 1:5</b>		<b>REVISION: A</b>	
				<b>SHEET 81</b>			

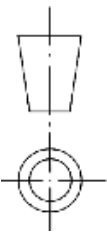

UCP-206  
QUANTITY: 02

UNLESS OTHERWISE SPECIFIED: STD. TOLERANCE DIMENSIONS ARE IN MILLIMETER MILLIMETER: ±0.1, ANGULAR: ± 0.05° * DOES NOT APPLY TO HOLE SIZE				BANGLADESH RICE RESEARCH INSTITUTE SFMRA PROJECT, FMPHT DIVISION		DO NOT SCALE DRAWING	
DETAILS		NAME	SIGNATURE	DATE	FINISH: NONE		
DRAWN		ENGR. SHAFER JAHAN KHAN	S J K	06-MAR-2024	FIRST ISSUED: 17-FEB-2024		
CHK'D		DR. MD. MOSHARRAF HOSSAIN	M M H	26-MAR-2024	TITLE: BRR I MINI RICE HULLER (BRR I RM2024B)		
APP'VD		DR. AKMA SAIFUL ISLAM	A S I	30-APR-2024	DRG. NAME: UCP206		
THIRD ANGLE PROJECTION:				DWG NO: SFMRA-S3-048			SHEET 82
NOTE: DEBURR AND BREAK SHARP EDGES ALL BENDS MIN. RADIUS UNLESS SPECIFIED		OUTSOURCING: VENDOR		MATERIAL: Cast Alloy Steel			WEIGHT: 1190.67g
		SCALE: 1:2		REVISION:			A

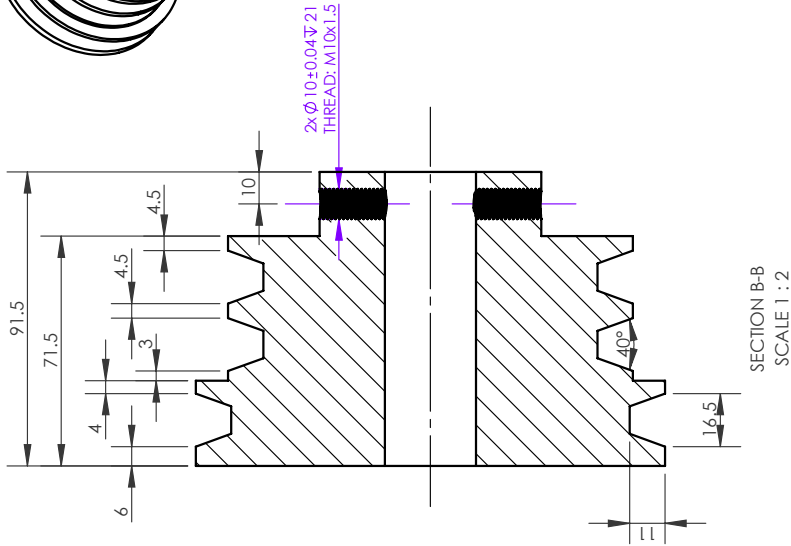
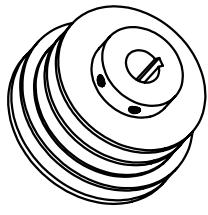

SECTION B-B  
SCALE 1 : 2

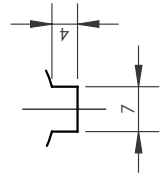
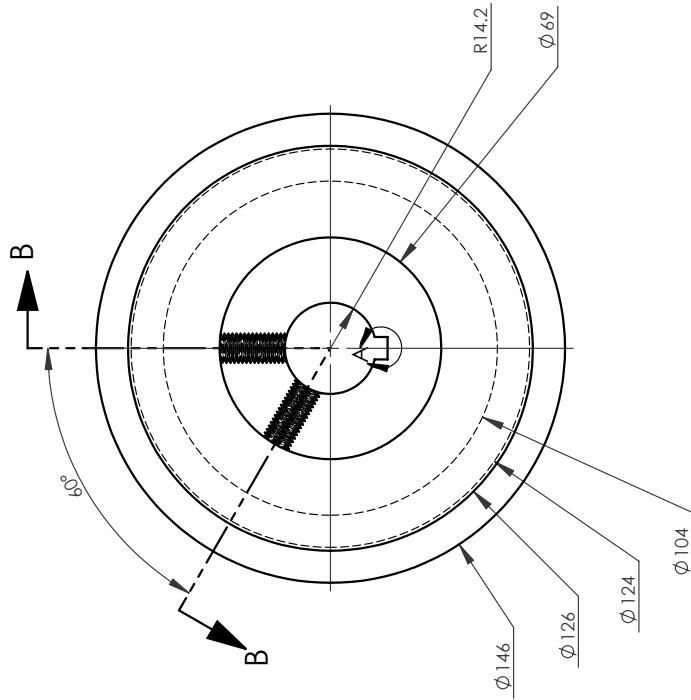

DETAIL A  
SCALE 1 : 1

**NOTE:** DEBURR AND BREAK SHARP EDGES ALL BENDS MIN. RADIUS UNLESS SPECIFIED

		<b>BANGLADESH RICE RESEARCH INSTITUTE</b> SFMRA PROJECT, FMPHT DIVISION		DO NOT SCALE DRAWING
UNLESS OTHERWISE SPECIFIED: STD. TOLERANCE DIMENSIONS ARE IN MILLIMETER MILLIMETER: ± 0.1, ANGULAR: ± 0.05° * DOES NOT APPLY TO HOLE SIZE		DRAWN: ENGR. SHAFEE JAHAN KHAN CHK'D: DR. MD. MOSHARRAF HOSSAIN APP'VD: DR. AKMAJIBUL ISLAM	DATE: 06-MAR-2024 DATE: 26-MAR-2024 DATE: 30-APR-2024	FINISH: NONE FIRST ISSUED: 17-FEB-2024
TITLE: <b>BRI MINI RICE HULLER (BRI RM2024B)</b>		DRG. NAME: <b>BLOWER PULLEY</b>		
DWG NO: SFMRA-53-049		MANUFACTURING METHOD: MACHINING		
MATERIAL: Gray Cast Iron		WEIGHT: 6175.34 g		
SCALE: 1:2		SHEET 83		
REVISION: A		REVISION: A		

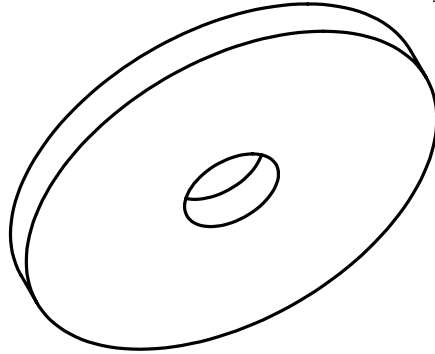

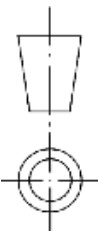

WASHER  
 OUTER DIA: 35mm  
 INNER DIA: 8mm  
 THICKNESS: 3mm

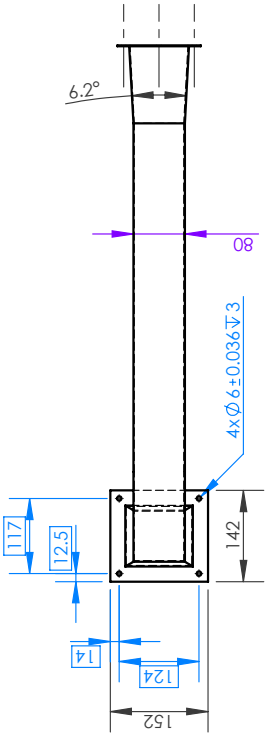
UNLESS OTHERWISE SPECIFIED: STD. TOLERANCE DIMENSIONS ARE IN MILLIMETER MILLIMETER: ±0.1, ANGULAR: ± 0.05° * DOES NOT APPLY TO HOLE SIZE				BANGLADESH RICE RESEARCH INSTITUTE SFMRA PROJECT, FMPHT DIVISION		DO NOT SCALE DRAWING	
DETAILS		NAME	SIGNATURE	DATE	FINISH: NONE		
DRAWN		ENGR. SHAFER JAHAN KHAN	S J K	06-MAR-2024	FIRST ISSUED: 17-FEB-2024		
CHK'D		DR. MD. MOSHARRAF HOSSAIN	M M H	26-MAR-2024	TITLE: BRRI MINI RICE HULLER (BRRI RM2024B)		
APP'VD		DR. AKMAJAIUL ISLAM	A S I	30-APR-2024	DRG. NAME: BLOWER WASHER		
THIRD ANGLE PROJECTION:				DWG NO: SFMRA-S3-050			
NOTE: DEBURR AND BREAK SHARP EDGES ALL BENDS MIN. RADIUS UNLESS SPECIFIED		MANUFACTURING METHOD: MACHINING, BENDING & WELDING		MATERIAL: Plain Carbon Steel			
		SCALE: 2:1		SHEET 84		REVISION: A	
		WEIGHT: 21.34 g		A4		A	

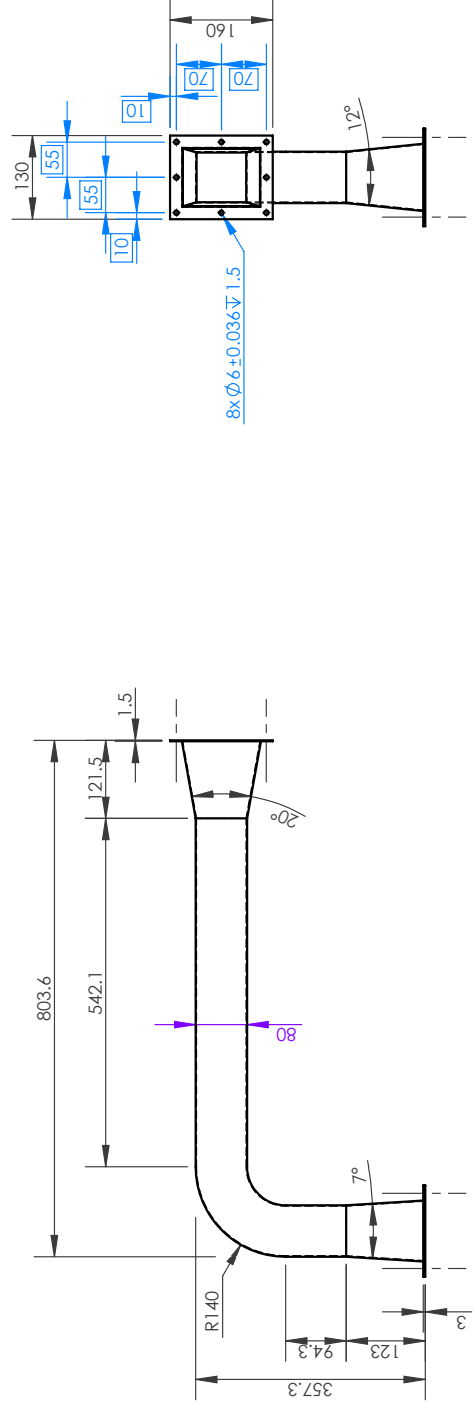
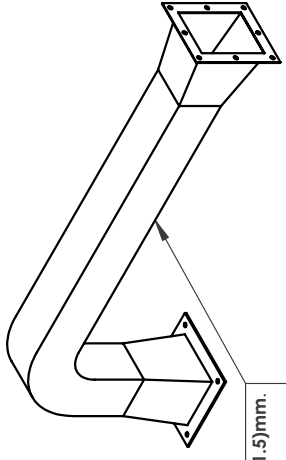

**N.B:** RECTANGULAR SHAPED (80x80x1.5)mm.  
\*SHEET THICKNESS: 1.5mm.



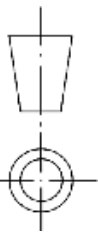

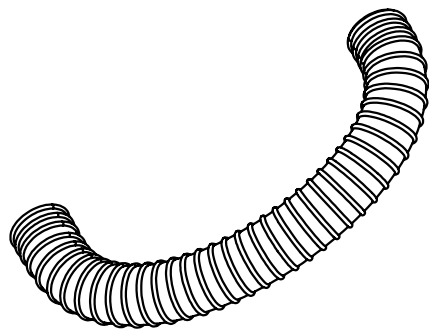
UNLESS OTHERWISE SPECIFIED: STD. TOLERANCE DIMENSIONS ARE IN MILLIMETER MILLIMETER: ±0.1, ANGULAR: ± 0.05° * DOES NOT APPLY TO HOLE SIZE				<b>BANGLADESH RICE RESEARCH INSTITUTE</b> SFMRA PROJECT, FMPHT DIVISION		DO NOT SCALE DRAWING	
DETAILS	NAME	SIGNATURE	DATE	TITLE: BRRI MINI RICE HULLER (BRRI RM2024B)		FINISH: NONE	
DRAWN	ENGR. SHAFER JAHAN KHAN	S J K	06-MAR-2024	DRG. NAME: BLOWER UPPER HOLD PART		FIRST ISSUED: 17-FEB-2024	
CHK'D	DR. MD. MOHARRAF HOSSAIN	M M H	26-MAR-2024	DWG NO: SFMRA-S3-051			
APP'VD	DR. AKMAJIBUL ISLAM	A S I	30-APR-2024	MANUFACTURING METHOD: MACHINING, BENDING & WELDING			
THIRD ANGLE PROJECTION:						MATERIAL: Plain Carbon Steel	
				SCALE: 1:10		WEIGHT: 4331.16 g	
				SHEET 85		REVISION: A	
<b>NOTE:</b> DEBURR AND BREAK SHARP EDGES ALL BENDS MIN. RADIUS UNLESS SPECIFIED							

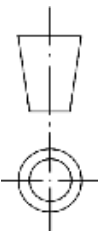

N.B: HOSE PIPE INNER DIA 70mm.

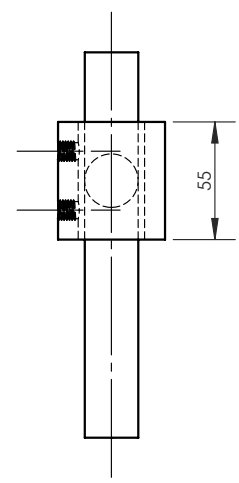
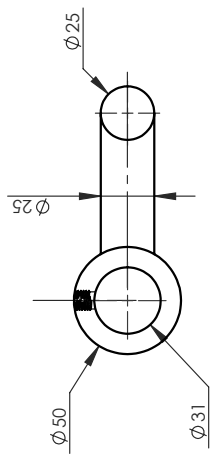
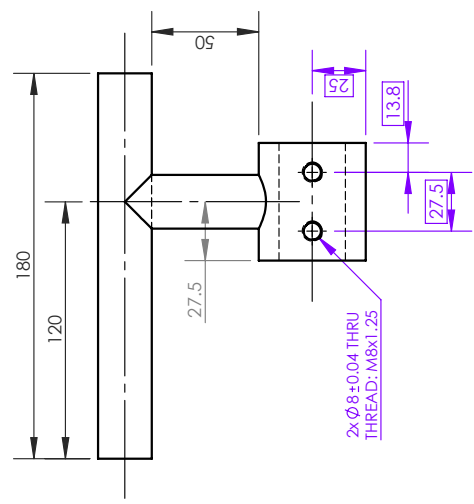
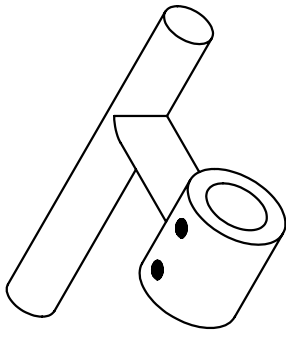
UNLESS OTHERWISE SPECIFIED: STD. TOLERANCE DIMENSIONS ARE IN MILLIMETER MILLIMETER: ±0.1, ANGULAR: ± 0.05° * DOES NOT APPLY TO HOLE SIZE				<b>BANGLADESH RICE RESEARCH INSTITUTE</b> SFMRA PROJECT, FMPHT DIVISION		DO NOT SCALE DRAWING	
DETAILS		NAME	SIGNATURE	DATE	FINISH: NONE		
DRAWN		ENGR. SHAFER JAHAN KHAN	S J K	06-MAR-2024	FIRST ISSUED: 17-FEB-2024		
CHK'D		DR. MD. MOSHARRAF HOSAIN	M M H	26-MAR-2024	TITLE: BRR MINI RICE HULLER (BRR RM2024B)		
APP'VD		DR. AKMA SAIFUL ISLAM	A S I	30-APR-2024	DRG. NAME: HOSE PIPE		
THIRD ANGLE PROJECTION:				DWG NO: SFMRA-33-052			REVISION: A
NOTE: DEBURR AND BREAK SHARP EDGES ALL BENDS MIN. RADIUS UNLESS SPECIFIED		OUTSOURCING: VENDOR		SCALE: 1:10			SHEET: 86
		MATERIAL: Silicon Rubber		WEIGHT: 615.52 g			A4

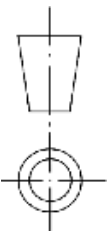

UNLESS OTHERWISE SPECIFIED: STD. TOLERANCE DIMENSIONS ARE IN MILLIMETER MILLIMETER: ±0.1, ANGULAR: ±0.05° * DOES NOT APPLY TO HOLE SIZE			<b>BANGLADESH RICE RESEARCH INSTITUTE</b> SFMRA PROJECT, FMPHT DIVISION		DO NOT SCALE DRAWING
	DETAILS	NAME	SIGNATURE	DATE	FINISH: NONE
DRAWN	ENGR. SHAFER JAHAN KHAN	S J K	08-MAR-2024	FIRST ISSUED: 17-FEB-2024	
CHK'D	DR. MD. MOSHARRAF HOSSAIN	M M H	26-MAR-2024	TITLE: BRR I MINI RICE HULLER (BRR I RM2024B)	
APP'VD	DR. AKMAJIBUL ISLAM	A S I	30-APR-2024	DRG. NAME: TENSION SHAFT - 2	
THIRD ANGLE PROJECTION:					
DWG NO: SFMRA-S4-053 DRG. NAME: TENSION SHAFT - 2 MANUFACTURING METHOD: MACHINING MATERIAL: Plain Carbon Steel SCALE: 1:3			WEIGHT: 1401.05 g REVISION: A		

**NOTE:** DEBURR AND BREAK SHARP EDGES ALL BENDS MIN. RADIUS UNLESS SPECIFIED

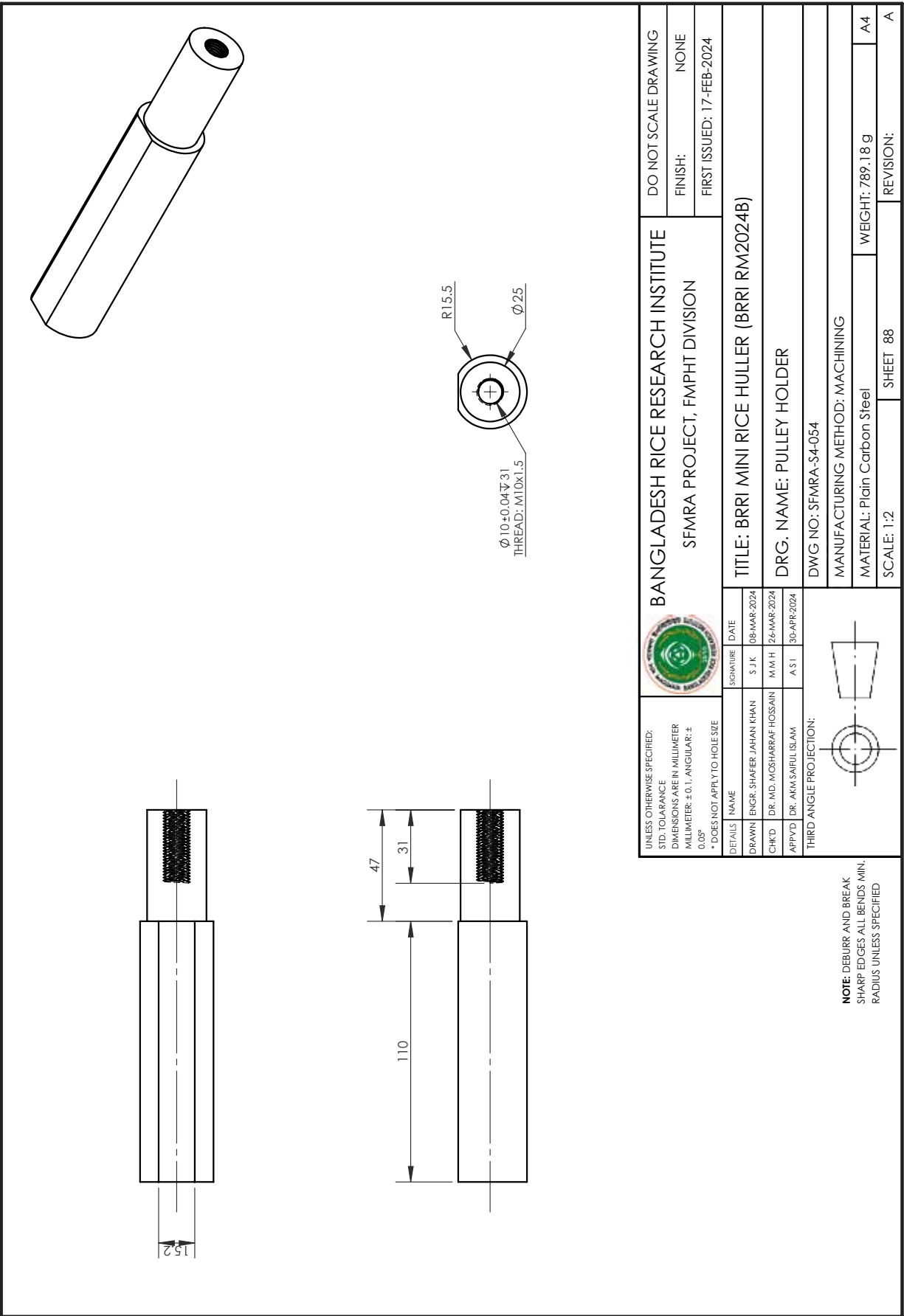

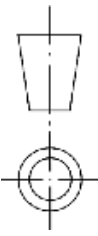
UNLESS OTHERWISE SPECIFIED: STD. TOLERANCE DIMENSIONS ARE IN MILLIMETER MILLIMETER: ±0.1, ANGULAR: ± 0.05° * DOES NOT APPLY TO HOLE SIZE		 <b>BANGLADESH RICE RESEARCH INSTITUTE</b> SFMRA PROJECT, FMPHT DIVISION		DO NOT SCALE DRAWING
DETAILS		SIGNATURE	DATE	FINISH: NONE
DRAWN	ENGR. SHAFER JAHAN KHAN	S J K	08-MAR-2024	FIRST ISSUED: 17-FEB-2024
CHK'D	DR. MD. MOSHARRAF HOSSAIN	M M H	26-MAR-2024	
APP'VD	DR. AKMAJIBUL ISLAM	A S I	30-APR-2024	
THIRD ANGLE PROJECTION:				
TITLE: <b>BRI MINI RICE HULLER (BRI RM2024B)</b> DRG. NAME: PULLEY HOLDER DWG NO: SFMRA-54-054 MANUFACTURING METHOD: MACHINING MATERIAL: Plain Carbon Steel SCALE: 1:2 WEIGHT: 789.18 g SHEET 88 REVISION: A				

**NOTE:** DEBURR AND BREAK SHARP EDGES ALL BENDS MIN. RADIUS UNLESS SPECIFIED

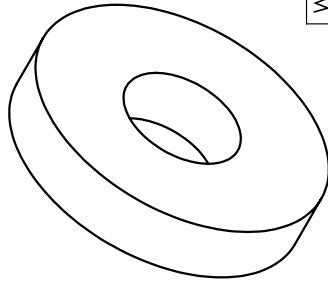

WASHER  
 OUTER DIA: 25mm  
 INNER DIA: 10mm  
 THICKNESS: 5mm

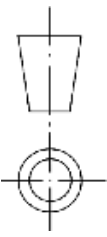
UNLESS OTHERWISE SPECIFIED: STD. TOLERANCE DIMENSIONS ARE IN MILLIMETER MILLIMETER: ±0.1, ANGULAR: ± 0.05° * DOES NOT APPLY TO HOLE SIZE		 <b>BANGLADESH RICE RESEARCH INSTITUTE</b> SFMRA PROJECT, FMPHT DIVISION		DO NOT SCALE DRAWING
DETAILS NAME SIGNATURE DATE DRAWN ENGR. SHAFIEE JAHAN KHAN S J K 08-MAR-2024 CHK'D DR. MD. MOSHARRAF HOSSAIN M M H 26-MAR-2024 APP'VD DR. AKMA SAIFUL ISLAM A S I 30-APR-2024		<b>TITLE: BRRI MINI RICE HULLER (BRRI RM2024B)</b>  DRG. NAME: WASHER DWG NO: SFMRA-54-055 SOURCING: VENDOR MATERIAL: Plain Carbon Steel SCALE: 2:1		FINISH: NONE FIRST ISSUED: 17-FEB-2024
THIRD ANGLE PROJECTION:				WEIGHT: 16.08 g
<b>NOTE: DEBURR AND BREAK SHARP EDGES ALL BENDS MIN. RADIUS UNLESS SPECIFIED</b>		SHEET 89		REVISION: A

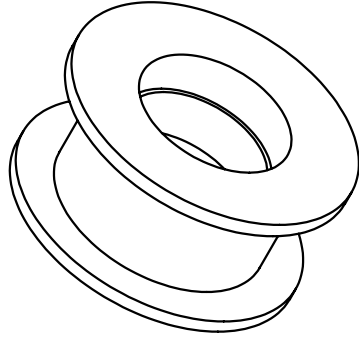
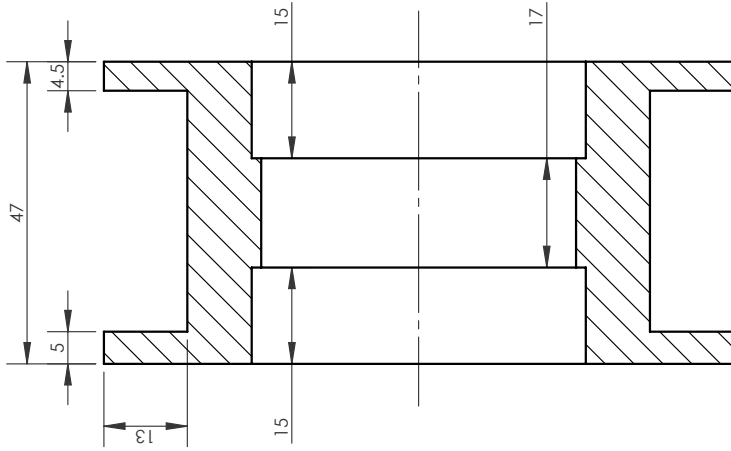
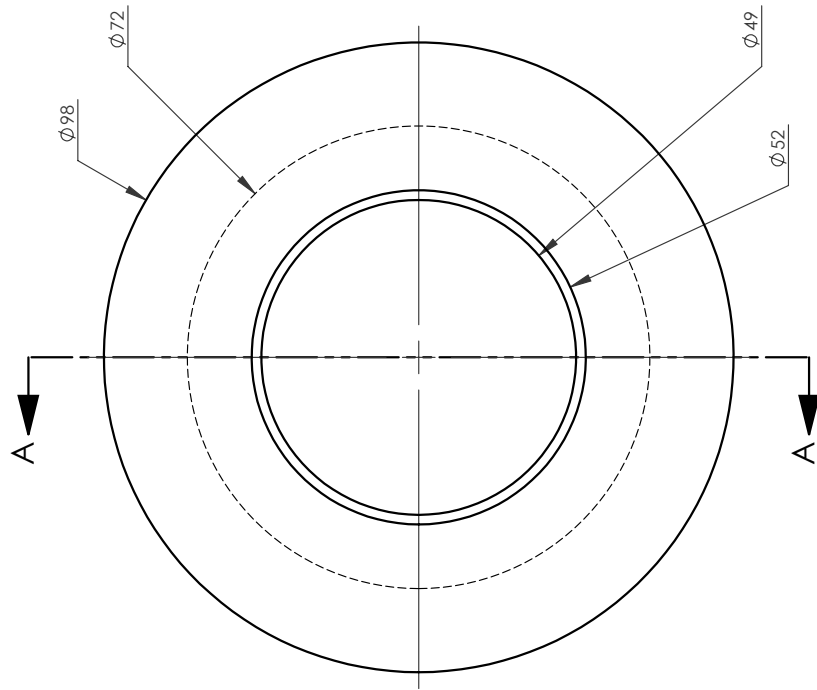

SECTION A-A  
SCALE 1 : 1

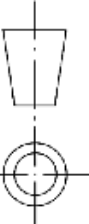
UNLESS OTHERWISE SPECIFIED: STD. TOLERANCE DIMENSIONS ARE IN MILLIMETER MILLIMETER: ±0.1, ANGULAR: ± 0.05° * DOES NOT APPLY TO HOLE SIZE		 <b>BANGLADESH RICE RESEARCH INSTITUTE</b> SFMRA PROJECT, FMPHT DIVISION		DO NOT SCALE DRAWING
DETAILS	NAME	SIGNATURE	DATE	FINISH: NONE
DRAWN	ENGR. SHAFER JAHAN KHAN	S J K	08-MAR-2024	FIRST ISSUED: 17-FEB-2024
CHK'D	DR. MD. MOHARRAF HOSSAIN	M M H	26-MAR-2024	
APP'VD	DR. AKMAJIBUL ISLAM	A S I	30-APR-2024	
THIRD ANGLE PROJECTION:				
TITLE: <b>BRRI MINI RICE HULLER (BRRI RM2024B)</b> DRG. NAME: TENSION PULLEY DWG NO: SFMRA-54-056 MANUFACTURING METHOD: MACHINING MATERIAL: Gray Cast Iron SCALE: 1:2 WEIGHT: 925.71 g SHEET 90 REVISION: A				

**NOTE:** DEBURR AND BREAK  
SHARP EDGES ALL BENDS MIN.  
RADIUS UNLESS SPECIFIED

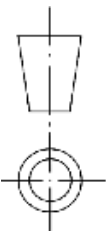

6205 BEARING  
QUANTITY: 02

UNLESS OTHERWISE SPECIFIED: STD. TOLERANCE DIMENSIONS ARE IN MILLIMETER MILLIMETER: ±0.1, ANGULAR: ± 0.05° * DOES NOT APPLY TO HOLE SIZE				<b>BANGLADESH RICE RESEARCH INSTITUTE</b> SFMRA PROJECT, FMPHT DIVISION		DO NOT SCALE DRAWING	
DETAILS		NAME	SIGNATURE	DATE	TITLE: BRR I MINI RICE HULLER (BRR RM2024B)		
DRAWN	ENGR. SHAFER JAHAN KHAN	S J K		08-MAR-2024	DRG. NAME: 6205 RS BEARING - USED IN TENSION		
CHK'D	DR. MD. MOSHARRAF HOSSAIN	M M H		26-MAR-2024	DWG NO: SFMRA-S4-057		
APP'VD	DR. AKMAJILUL ISLAM	A S I		30-APR-2024	OUTSOURCING: VENDOR		
THIRD ANGLE PROJECTION:							
NOTE: DEBURR AND BREAK SHARP EDGES ALL BENDS MIN. RADIUS UNLESS SPECIFIED				SCALE: 1:1			
				SHEET 91		REVISION: A	
				WEIGHT: N/A		A4	

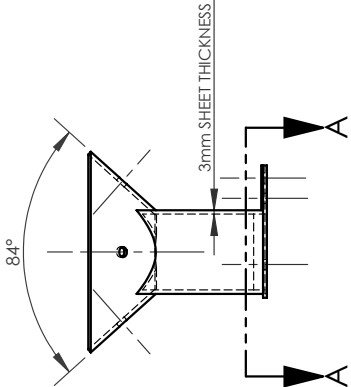
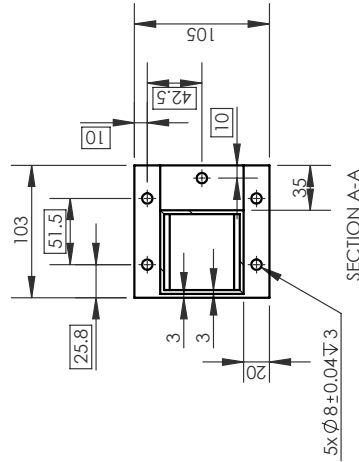
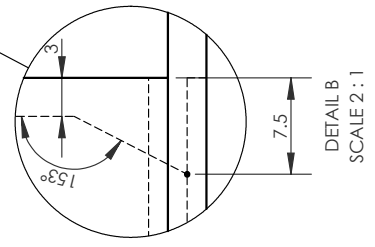
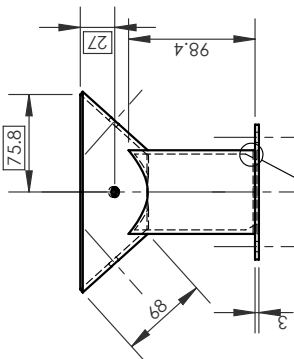
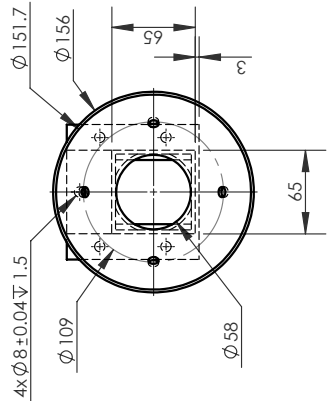
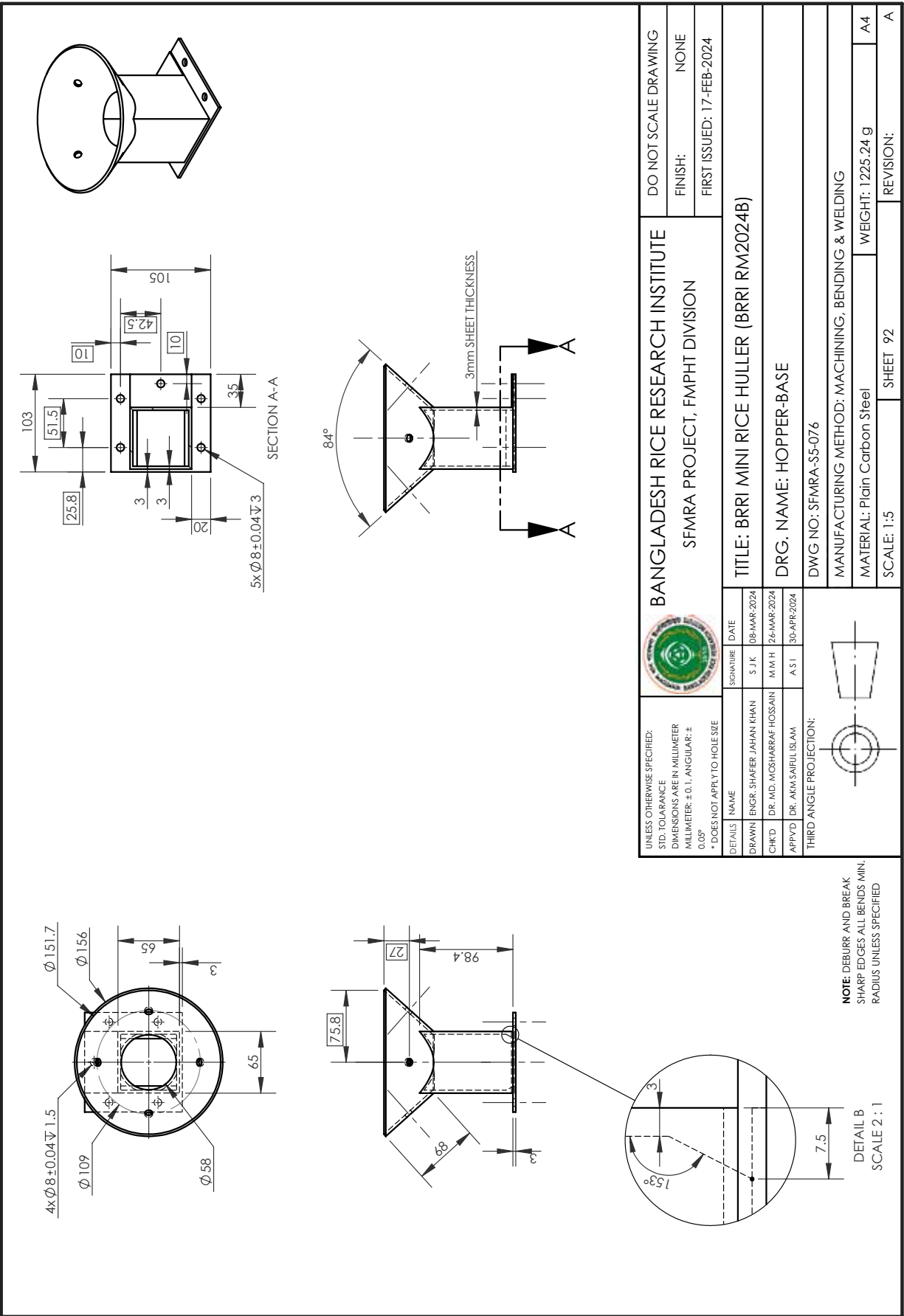

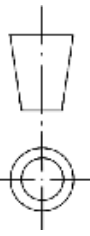
UNLESS OTHERWISE SPECIFIED: STD. TOLERANCE DIMENSIONS ARE IN MILLIMETER MILLIMETER: ±0.1, ANGULAR: ± 0.05° * DOES NOT APPLY TO HOLE SIZE				<b>BANGLADESH RICE RESEARCH INSTITUTE</b> SFMRA PROJECT, FMPHT DIVISION		DO NOT SCALE DRAWING	
DETAILS	NAME	SIGNATURE	DATE	TITLE: BRRI MINI RICE HULLER (BRRI RM2024B)		FINISH: NONE	
DRAWN	ENGR. SHAFIEE JAHAN KHAN	S. J.K.	08-MAR-2024	DRG. NAME: HOPPER-BASE		FIRST ISSUED: 17-FEB-2024	
CHK'D	DR. MD. MOSHARRAF HOSSAIN	M.M.H.	26-MAR-2024	DWG NO: SFMRA-55-076			
APP'VD	DR. AKMA SAIFUL ISLAM	A.S.I.	30-APR-2024	MANUFACTURING METHOD: MACHINING, BENDING & WELDING			
THIRD ANGLE PROJECTION:							
NOTE: DEBURR AND BREAK SHARP EDGES ALL BENDS MIN. RADIUS UNLESS SPECIFIED				MATERIAL: Plain Carbon Steel		WEIGHT: 1225.24 g	
				SCALE: 1:5		SHEET 92	
				REVISION: A		A4	

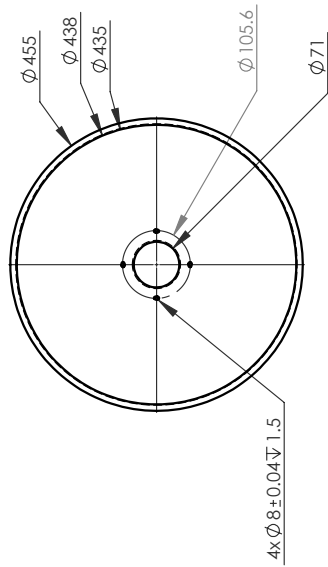

\*SHEET THICKNESS 1.5mm.

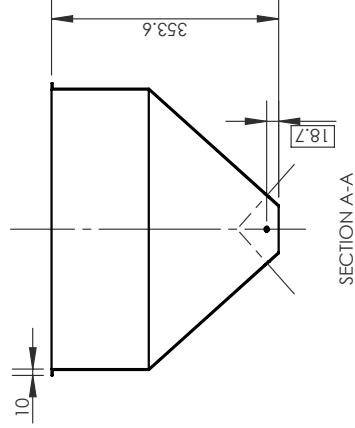
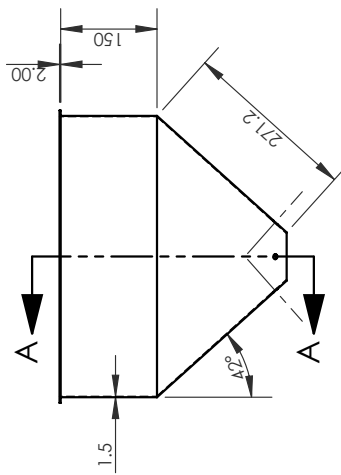
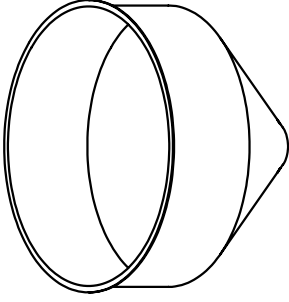

**BANGLADESH RICE RESEARCH INSTITUTE**  
 SFMRA PROJECT, FMPHT DIVISION

DO NOT SCALE DRAWING  
 FINISH: NONE  
 FIRST ISSUED: 17-FEB-2024

TITLE: BRRI MINI RICE HULLER (BRRI RM2024B)

DRG. NAME: HOPPER

DWG NO: SFMRA-SS-077

MANUFACTURING METHOD: MACHINING, BENDING & WELDING

MATERIAL: Plain Carbon Steel

WEIGHT: 5161.18 g

REVISION: A

A4

SHEET 93

SCALE: 1:10

UNLESS OTHERWISE SPECIFIED:  
 STD. TOLERANCE  
 DIMENSIONS ARE IN MILLIMETER  
 MILLIMETER:  $\pm 0.1$ , ANGULAR:  $\pm 0.05^\circ$   
 \* DOES NOT APPLY TO HOLE SIZE

DETAILS	NAME	SIGNATURE	DATE
DRAWN	ENGR. SHAFER JAHAN KHAN	S J K	08-MAR-2024
CHK'D	DR. MD. MOHAMMAD HOSSAIN	M M H	26-MAR-2024
APP'VD	DR. AKMAJIBUL ISLAM	A S I	30-APR-2024

THIRD ANGLE PROJECTION:

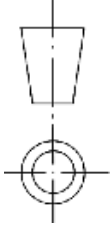

**NOTE:** DEBURR AND BREAK SHARP EDGES ALL BENDS MIN. RADIUS UNLESS SPECIFIED

UNLESS OTHERWISE SPECIFIED:  
 STD. TOLERANCE DIMENSIONS ARE IN MILLIMETER  
 MILLIMETER: ±0.1, ANGULAR: ±0.05°  
 \* DOES NOT APPLY TO HOLE SIZE

DETAILS	NAME	SIGNATURE	DATE
DRAWN	ENGR. SHAFER JAHAN KHAN	S J K	08-MAR-2024
CHK'D	DR. MD. MOHARRAF HOSSAIN	M M H	26-MAR-2024
APP'VD	DR. AKMA SAIFUL ISLAM	A S I	30-APR-2024

THIRD ANGLE PROJECTION:

**NOTE:** DEBURR AND BREAK SHARP EDGES ALL BENDS MIN. RADIUS UNLESS SPECIFIED

**BANGLADESH RICE RESEARCH INSTITUTE**  
 SFMRA PROJECT, FMPHT DIVISION

**TITLE: BRRI MINI RICE HULLER (BRRI RM2024B)**

DRG. NAME: HOPPER - PADDY SUPPLY CONTROLLER  
 DWG NO: SFMRA-SS-078  
 MANUFACTURING METHOD: MACHINING  
 MATERIAL: Plain Carbon Steel  
 SCALE: 1:2

DO NOT SCALE DRAWING  
 FINISH: NONE  
 FIRST ISSUED: 17-FEB-2024

WEIGHT: 57.71 g  
 SHEET 94  
 REVISION: A

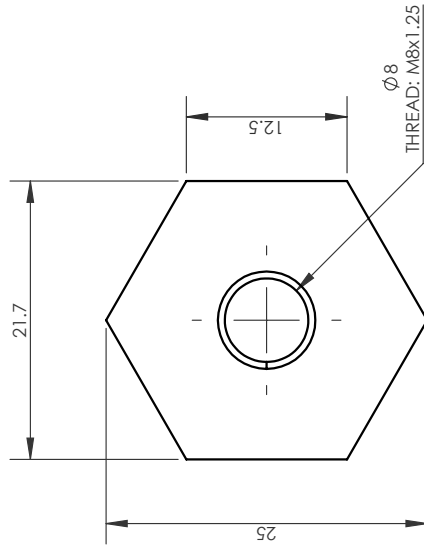
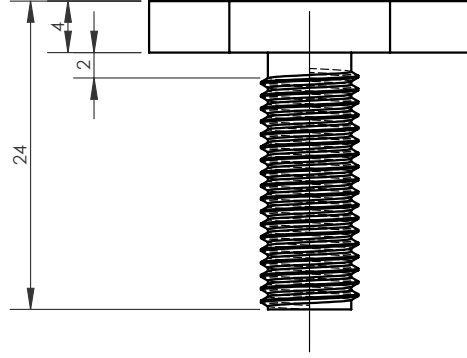
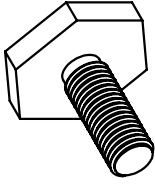

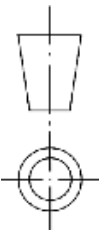
UNLESS OTHERWISE SPECIFIED: STD. TOLERANCE DIMENSIONS ARE IN MILLIMETER MILLIMETER: ±0.1, ANGULAR: ± 0.05° * DOES NOT APPLY TO HOLE SIZE				<b>BANGLADESH RICE RESEARCH INSTITUTE</b> SFMRA PROJECT, FMPHT DIVISION		DO NOT SCALE DRAWING	
DETAILS	NAME	SIGNATURE	DATE			FINISH:	NONE
DRAWN	ENGR. SHAFER JAHAN KHAN	S J K	08-MAR-2024			FIRST ISSUED:	17-FEB-2024
CHK'D	DR. MD. MOSHARRAF HOSSAIN	M M H	26-MAR-2024	<b>TITLE: BRRI MINI RICE HULLER (BRRI RM2024B)</b>			
APP'VD	DR. AKMA SAIFUL ISLAM	A S I	30-APR-2024	DRG. NAME: HOPPER THREAD KEY - M8 DWG NO: SFMRA-SS-079			
THIRD ANGLE PROJECTION:							
<b>NOTE: DEBURR AND BREAK SHARP EDGES ALL BENDS MIN. RADIUS UNLESS SPECIFIED</b>				MANUFACTURING METHOD: MACHINING MATERIAL: Plain Carbon Steel SCALE: 2:1		WEIGHT: 18.56 g REVISION: A	
				SHEET 95		A	

N.B: SHEET NO 109 & 110 ARE KEEPING SAME DRAWING, (MUST CHECK).  
 \*ONLY FRONT & RIGHT VIEWS HAS SHOWN HERE.  
 \*TOP VIEW IS IN THE NEXT SHEET.  
 \*SHEET THICK: 1.5mm.

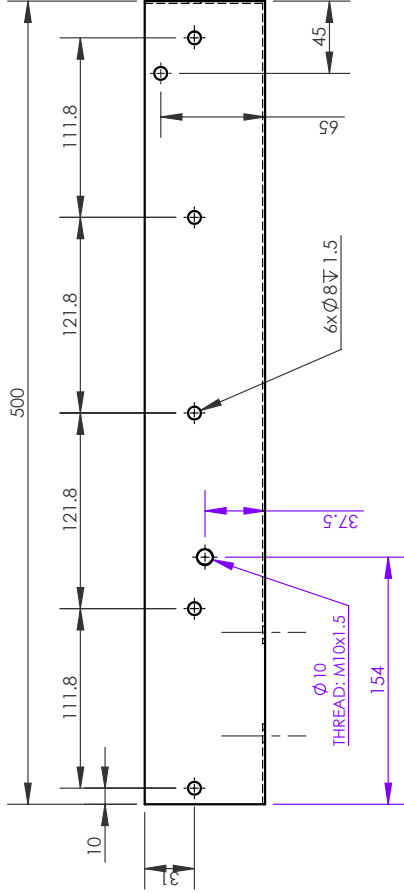
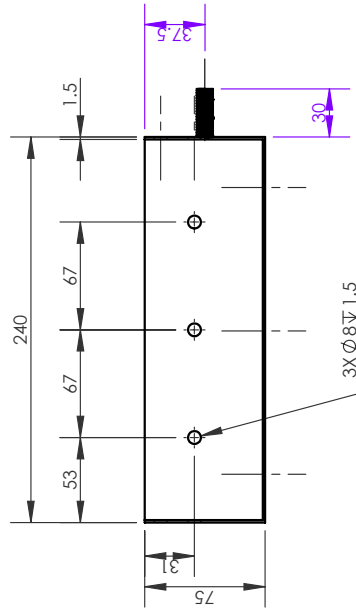
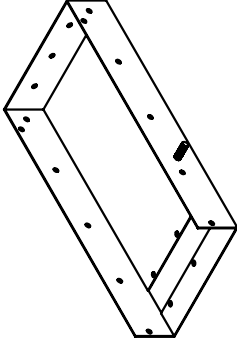

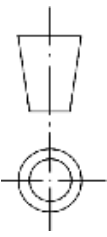
UNLESS OTHERWISE SPECIFIED: STD. TOLERANCE DIMENSIONS ARE IN MILLIMETER MILLIMETER: ±0.1, ANGULAR: ± 0.05° * DOES NOT APPLY TO HOLE SIZE			BANGLADESH RICE RESEARCH INSTITUTE SFMRA PROJECT, FMPHT DIVISION		DO NOT SCALE DRAWING
	DETAILS	NAME	SIGNATURE	DATE	FINISH: NONE
DRAWN	ENGR. SHAFER JAHAN KHAN	S J K	10-MAR-2024	FIRST ISSUED: 17-FEB-2024	
CHK'D	DR. MD. MOSHARRAF HOSSAIN	M M H	26-MAR-2024	TITLE: BRRI MINI RICE HULLER (BRRI RM2024B)	
APP'VD	DR. AKMA SAIFUL ISLAM	A S I	30-APR-2024	DRG. NAME: GRADER OUTER CASING	
THIRD ANGLE PROJECTION:					
NOTE: DEBURR AND BREAK SHARP EDGES ALL BENDS MIN. RADIUS UNLESS SPECIFIED			DWG NO: SFMRA-56-080		
MANUFACTURING METHOD: MACHINING, BENDING & WELDING			MATERIAL: Plain Carbon Steel WEIGHT: 2333.00 g		
SCALE: 1:5 SHEET 96			REVISION: A		

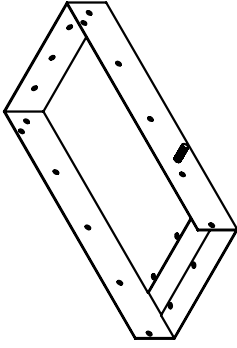

N.B: SHEET NO 109 & 110 ARE KEEPING SAME DRAWING.  
(MUST CHECK).  
\*TOP VIEW IS IN THE NEXT SHEET.  
\*SHEET THICK: 1.5mm.

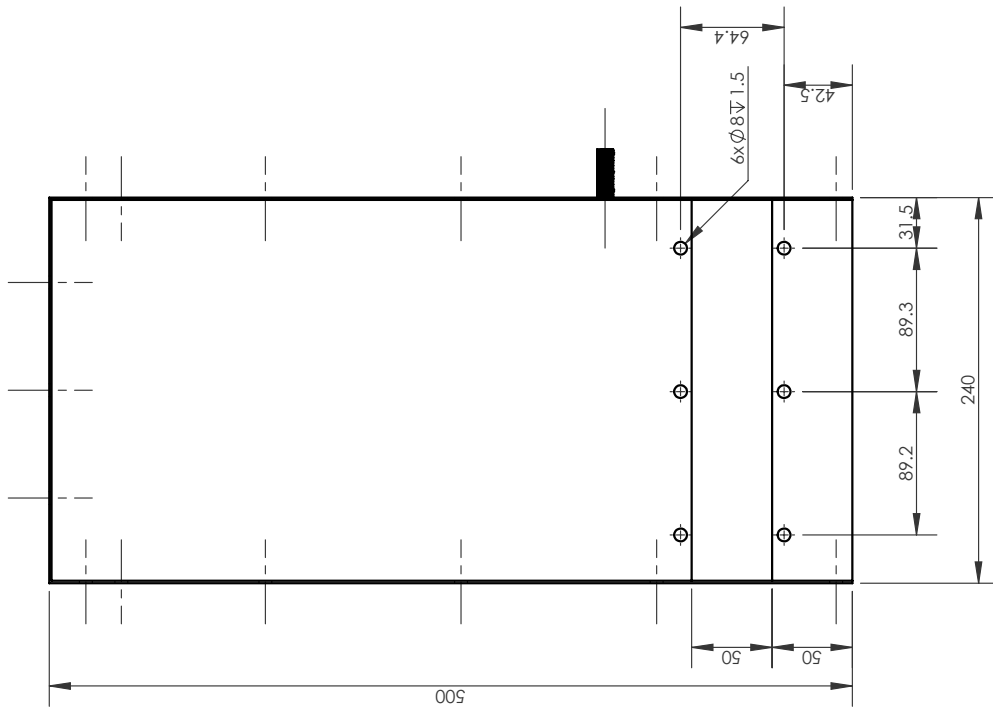

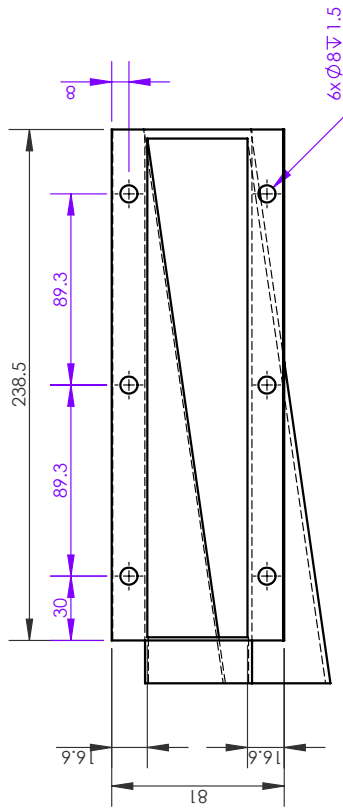

DWG NO: SFMIRA-S6-080  
SHEET NO: 97

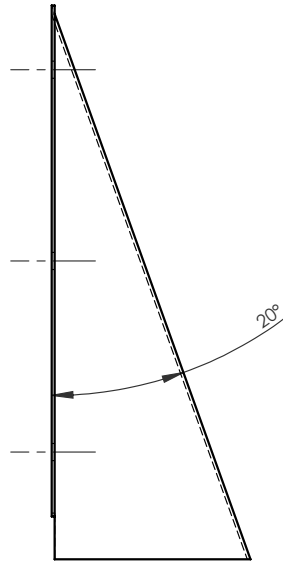
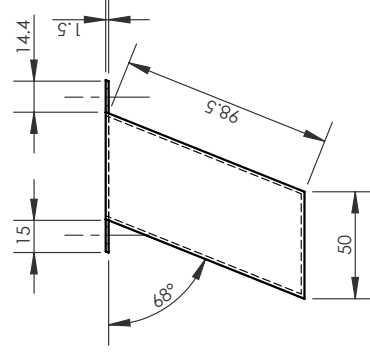
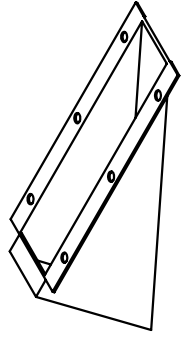

N.B: MODEL IS SYMMETRY FOR HOLES.

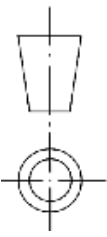

UNLESS OTHERWISE SPECIFIED: STD. TOLERANCE DIMENSIONS ARE IN MILLIMETER MILLIMETER: ±0.1, ANGULAR: ± 0.05° * DOES NOT APPLY TO HOLE SIZE			
DETAILS	NAME	SIGNATURE	DATE
DRAWN	ENGR. SHAFER JAHAN KHAN	S J K	10-MAR-2024
CHK'D	DR. MD. MOSHARRAF HOSSAIN	M M H	26-MAR-2024
APP'VD	DR. AKMA SAIFUL ISLAM	A S I	30-APR-2024
THIRD ANGLE PROJECTION:			
			
<b>NOTE:</b> DEBURR AND BREAK SHARP EDGES ALL BENDS MIN. RADIUS UNLESS SPECIFIED			
BANGLADESH RICE RESEARCH INSTITUTE SFMRA PROJECT, FMPHT DIVISION		DO NOT SCALE DRAWING FINISH: NONE FIRST ISSUED: 17-FEB-2024	
TITLE: BRRI MINI RICE HULLER (BRRI RM2024B)			
DRG. NAME: GRADER - BROKEN RICE LINE			
DWG NO: SFMRA-56-081			
MANUFACTURING METHOD: MACHINING, BENDING & WELDING			
MATERIAL: Plain Carbon Steel		WEIGHT: 517.48 g	
SCALE: 1:5		SHEET 98	
REVISION:		A	



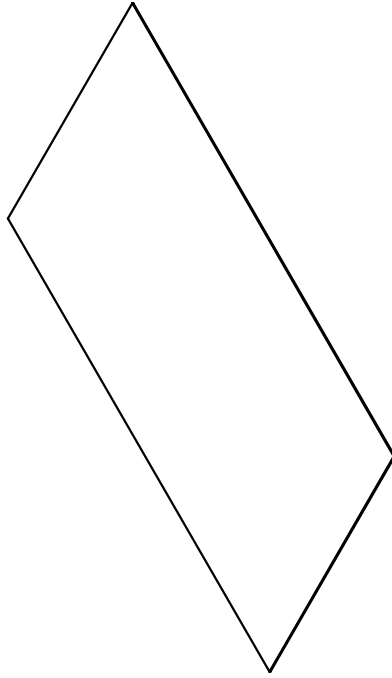

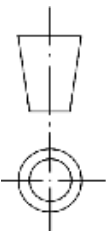

NET: SIZE 14

UNLESS OTHERWISE SPECIFIED: STD. TOLERANCE DIMENSIONS ARE IN MILLIMETER MILLIMETER: ±0.1, ANGULAR: ± 0.05° * DOES NOT APPLY TO HOLE SIZE				<b>BANGLADESH RICE RESEARCH INSTITUTE</b> SFMRA PROJECT, FMPHT DIVISION		DO NOT SCALE DRAWING	
DETAILS		NAME	SIGNATURE	DATE	TITLE: <b>BRR I MINI RICE HULLER (BRR RM2024B)</b>		
DRAWN	ENGR. SHAFER JAHAN KHAN	S J K		10-MAR-2024	DRG. NAME: GRADER NET		
CHK'D	DR. MD. MOSHARRAF HOSSAIN	M M H		26-MAR-2024	DWG NO: SFMRA-56-083		
APP'VD	DR. AKMAJIBUL ISLAM	A S I		30-APR-2024	MANUFACTURING METHOD: MACHINING, BENDING & WELDING		
THIRD ANGLE PROJECTION:							
MATERIAL: Plain Carbon Steel		WEIGHT: 921.53 g		SCALE: 1:5		REVISION: A	

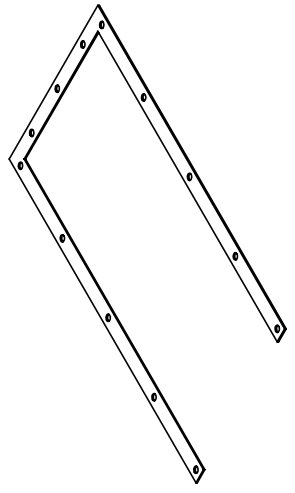
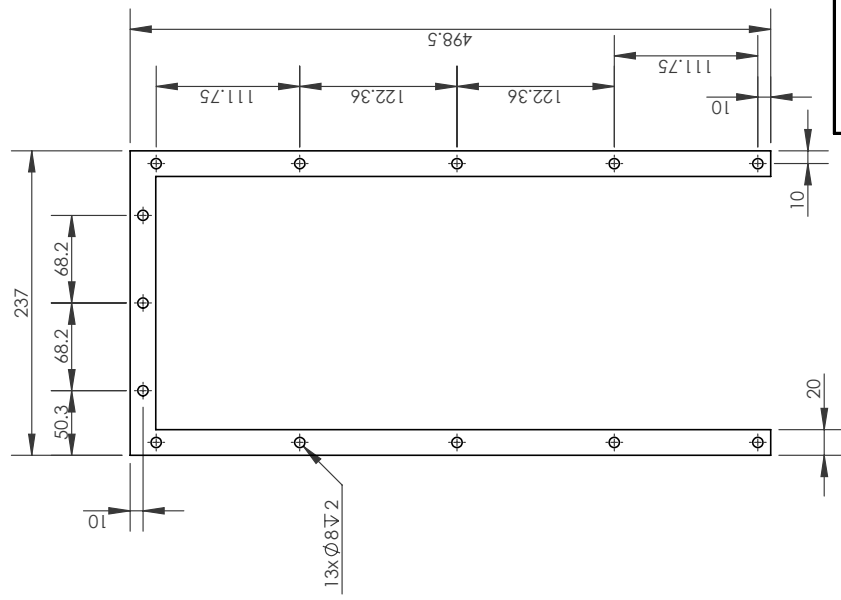
**NOTE:** DEBURR AND BREAK SHARP EDGES ALL BENDS MIN. RADIUS UNLESS SPECIFIED

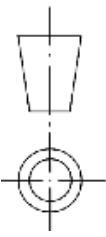
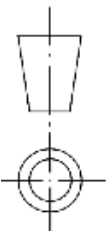

\*THICKNESS: 2mm.  
\*MODEL IS SYMMETRY.

UNLESS OTHERWISE SPECIFIED: STD. TOLERANCE DIMENSIONS ARE IN MILLIMETER MILLIMETER: ±0.1, ANGULAR: ±0.05° * DOES NOT APPLY TO HOLE SIZE				<b>BANGLADESH RICE RESEARCH INSTITUTE</b> SFMRA PROJECT, FMPHT DIVISION		DO NOT SCALE DRAWING	
DETAILS		NAME	SIGNATURE	DATE	FINISH: NONE		
DRAWN		ENGR. SHAFER JAHAN KHAN	S JK	10-MAR-2024	FIRST ISSUED: 17-FEB-2024		
CHK'D		DR. MD. MOSHARRAF HOSSAIN	M M H	26-MAR-2024	TITLE: BRRI MINI RICE HULLER (BRRI RM2024B)		
APP'VD		DR. AKMA SAIFUL ISLAM	A S I	30-APR-2024	DRG. NAME: GRADER NET FRAME - 1		
THIRD ANGLE PROJECTION:				DWG NO: SFMRA-56-084			
NOTE: DEBURR AND BREAK SHARP EDGES ALL BENDS MIN. RADIUS UNLESS SPECIFIED				MANUFACTURING METHOD: MACHINING, BENDING & WELDING			
		MATERIAL: Plain Carbon Steel		WEIGHT: 362.33 g		A4	
		SCALE: 1:5		SHEET 101		REVISION: A	

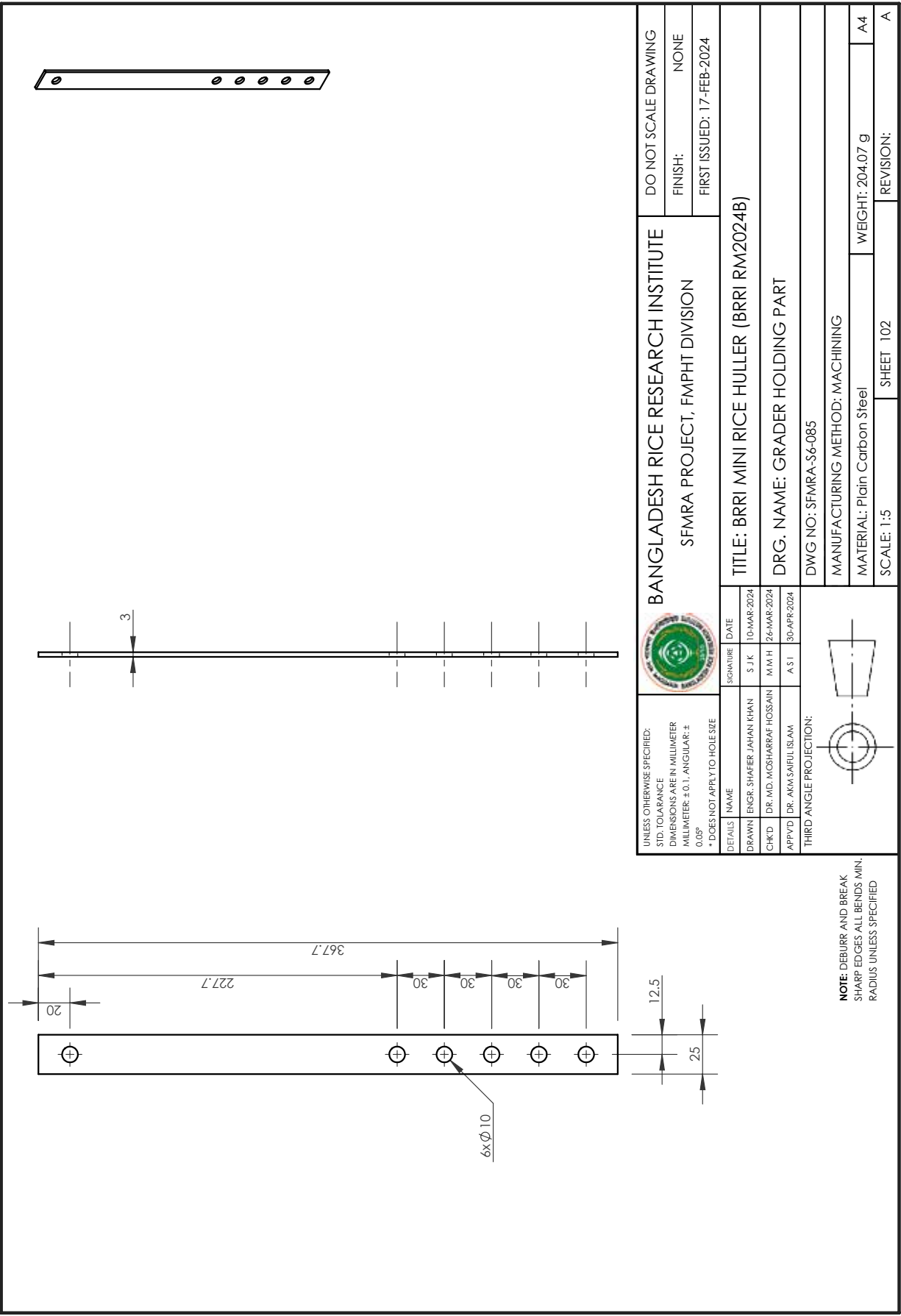

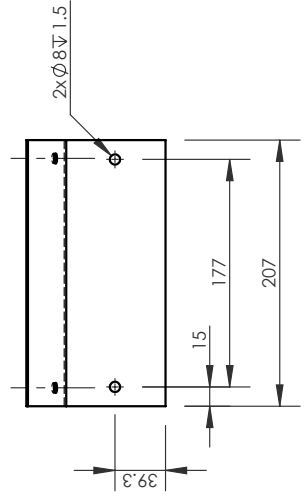
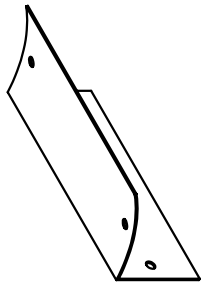
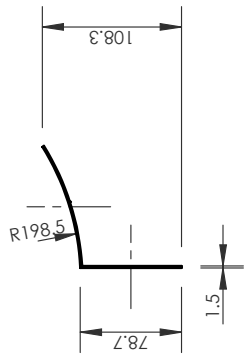
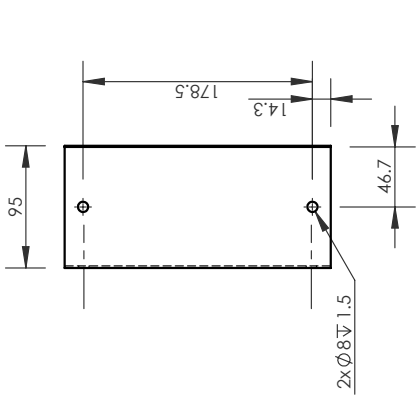

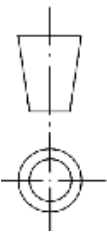
UNLESS OTHERWISE SPECIFIED: STD. TOLERANCE DIMENSIONS ARE IN MILLIMETER MILLIMETER: ±0.1, ANGULAR: ± 0.05° * DOES NOT APPLY TO HOLE SIZE				<b>BANGLADESH RICE RESEARCH INSTITUTE</b> SFMRA PROJECT, FMPHT DIVISION		DO NOT SCALE DRAWING	
DETAILS	NAME	SIGNATURE	DATE	TITLE: BRRI MINI RICE HULLER (BRRI RM2024B)		FINISH:	NONE
DRAWN	ENGR. SHAFER JAHAN KHAN	S JK	10-MAR-2024	DRG. NAME: POLISHER TO OUTPUT SIDE P ART-2		FIRST ISSUED: 17-FEB-2024	
CHK'D	DR. MD. MOSHARRAF HOSSAIN	M M H	26-MAR-2024	DWG NO: SFMRA-57-086			
APP'VD	DR. AKMA SAIFUL ISLAM	A S I	30-APR-2024	MANUFACTURING METHOD: MACHINING, BENDING & WELDING			
THIRD ANGLE PROJECTION:						MATERIAL: Plain Carbon Steel	
				SCALE: 1:5		WEIGHT: 427.35 g	
				SHEET 103		REVISION: A	

**NOTE:** DEBURR AND BREAK SHARP EDGES ALL BENDS MIN. RADIUS UNLESS SPECIFIED

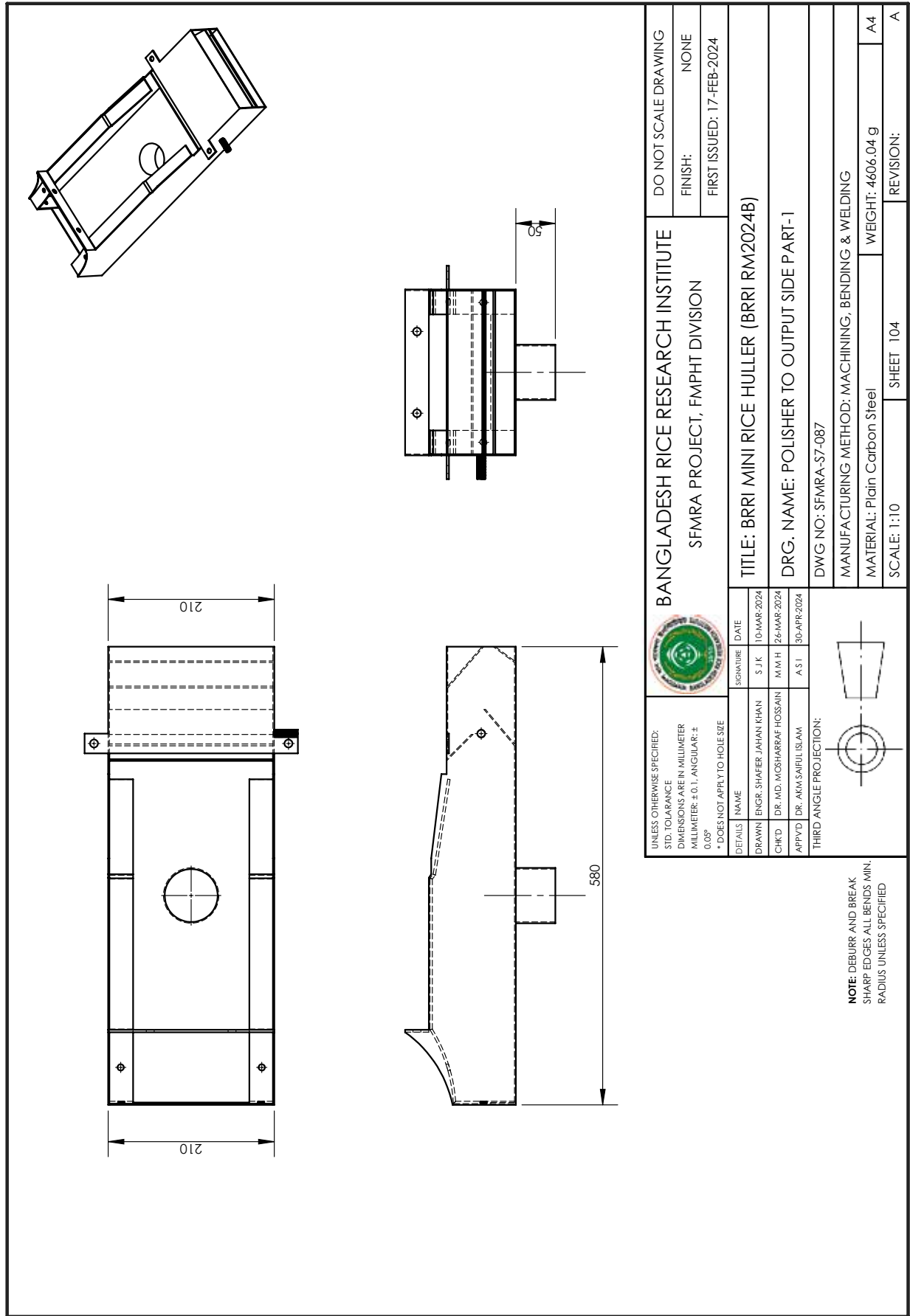

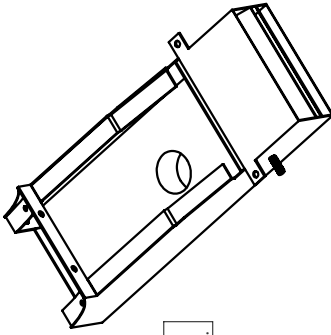

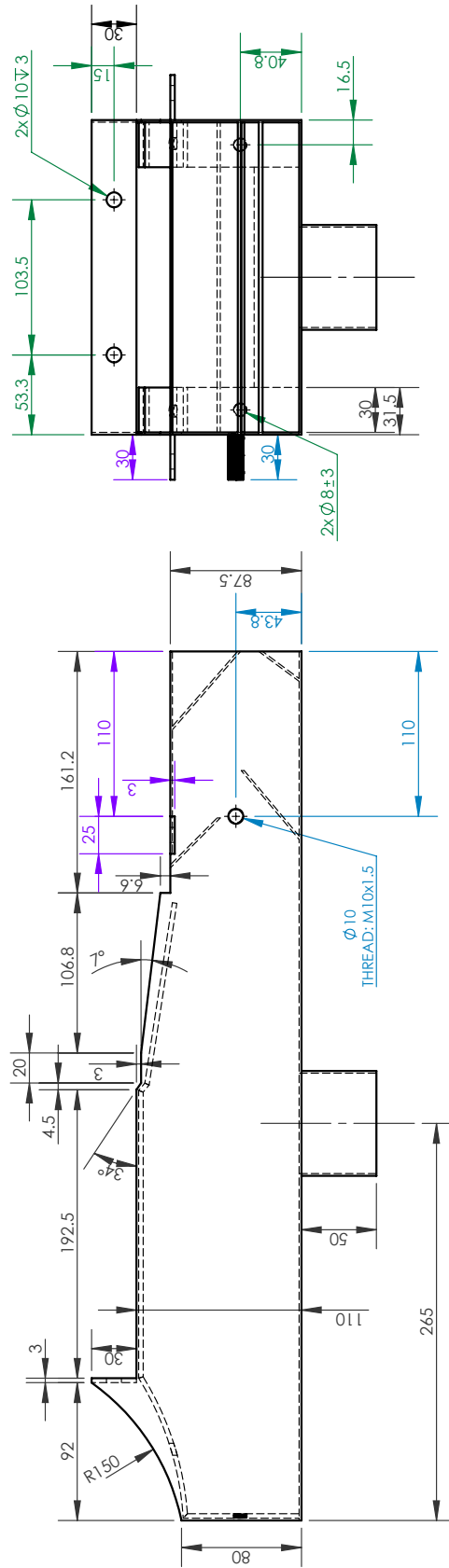

N.B: SHEET THICKNESS: 1.5mm.  
 \*ONLY FRONT & RIGHT VIEW HAS SHOWN HERE.

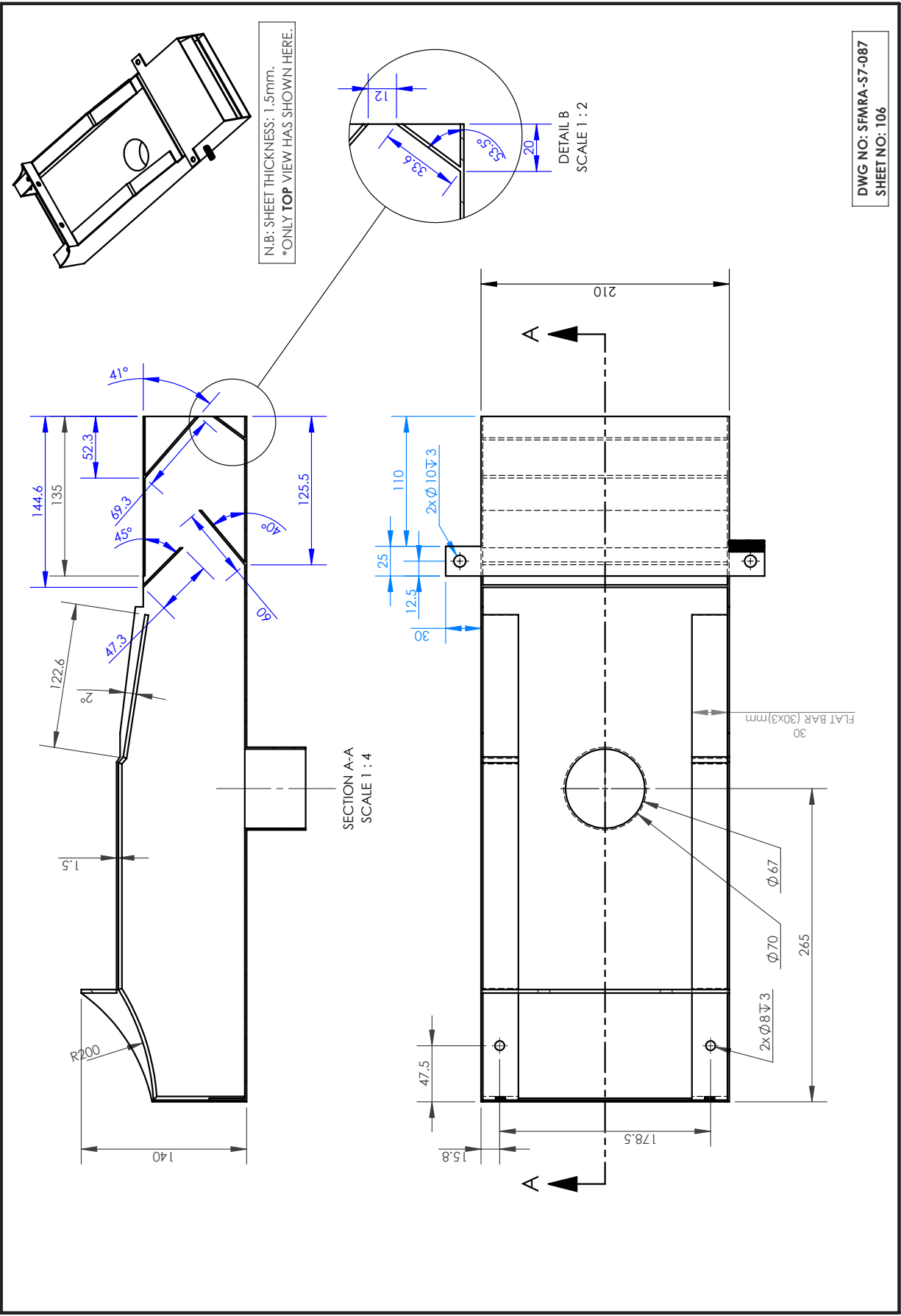

DWG NO: SFMRA-S7-087  
 SHEET NO: 105

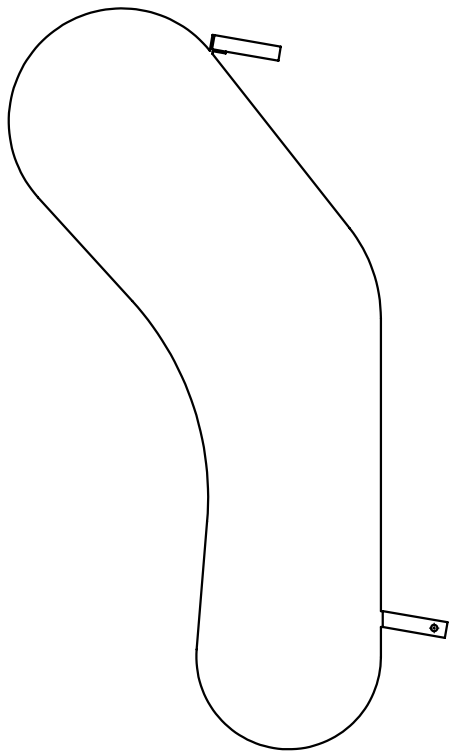
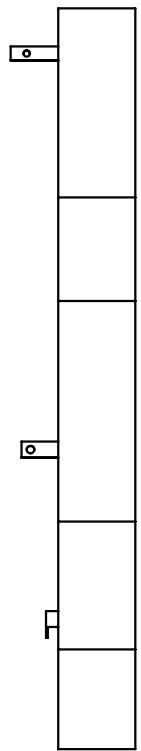
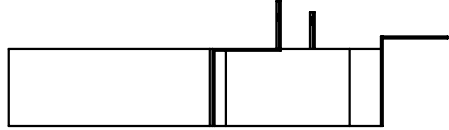

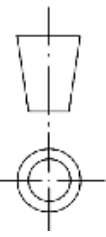

UNLESS OTHERWISE SPECIFIED: STD. TOLERANCE DIMENSIONS ARE IN MILLIMETER MILLIMETER: ±0.1, ANGULAR: ± 0.05° * DOES NOT APPLY TO HOLE SIZE				<b>BANGLADESH RICE RESEARCH INSTITUTE</b> SFMRA PROJECT, FMPHT DIVISION		DO NOT SCALE DRAWING	
DETAILS	NAME	SIGNATURE	DATE	<b>TITLE: BRRI MINI RICE HULLER (BRRI RM2024B)</b>		FINISH:	NONE
DRAWN	ENGR. SHAFER JAHAN KHAN	S J K	10-MAR-2024	<b>DRG. NAME: GUARD</b>		FIRST ISSUED: 17-FEB-2024	
CHK'D	DR. MD. MOSHARRAF HOSSAIN	M M H	26-MAR-2024	<b>DWG NO: SFMRA-088</b>			
APP'VD	DR. AKMAJIBUL ISLAM	A S I	30-APR-2024	<b>MANUFACTURING METHOD: MACHINING, BENDING &amp; WELDING</b>			
THIRD ANGLE PROJECTION:							
<b>NOTE: DEBURR AND BREAK SHARP EDGES ALL BENDS MIN. RADIUS UNLESS SPECIFIED</b>							
				MATERIAL: Plain Carbon Steel		WEIGHT: 8713.98 g	
				SCALE: 1:10		REVISION: A	
				SHEET 107		A	





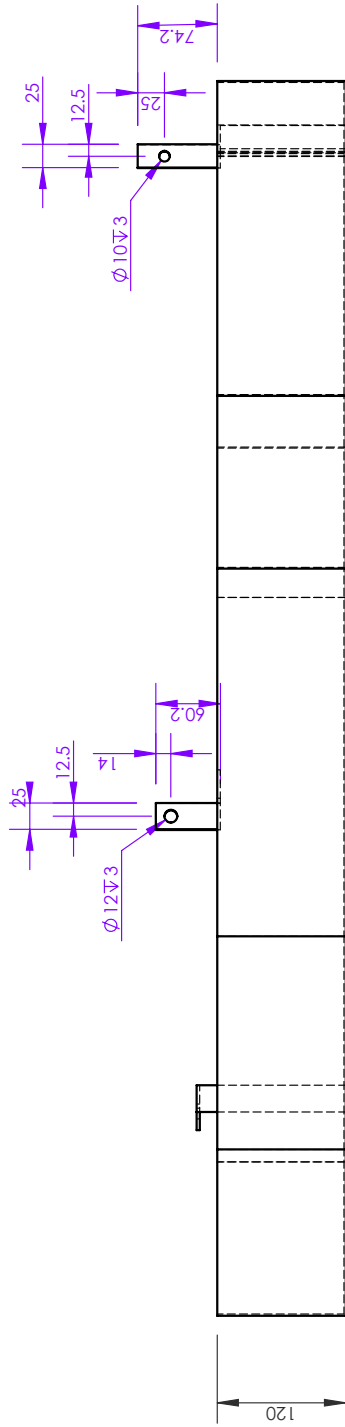

N.B: ONLY TOP VIEW.  
\*SHEET THICKNESS: 1.5mm.

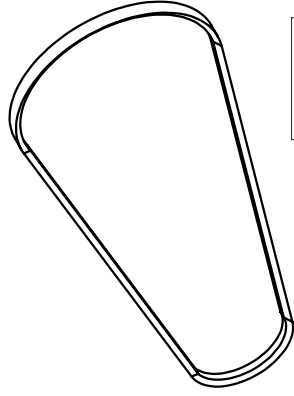

DRG. NO: SFMRA-088  
SHEET NO: 110

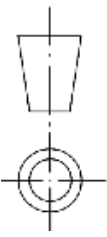

**TYPE B-64  
V-BELT**

UNLESS OTHERWISE SPECIFIED: STD. TOLERANCE DIMENSIONS ARE IN MILLIMETER MILLIMETER: ±0.1, ANGULAR: ± 0.05° * DOES NOT APPLY TO HOLE SIZE				<b>BANGLADESH RICE RESEARCH INSTITUTE</b> SFMRA PROJECT, FMPHT DIVISION		DO NOT SCALE DRAWING	
DETAILS		NAME	SIGNATURE	DATE			
CH'D	DR. MD. MOSHARRAF HOSSAIN	ENGR. SHAFER JAHAN KHAN	S J K	10-MAR-2024	TITLE: BRR I MINI RICE HULLER (BRR I RM2024B)		
APP'VD	DR. AKMA SAIFUL ISLAM	M M H	A S I	26-MAR-2024	DRG. NAME: V-BELT TYPE-B MODEL: B-64		
THIRD ANGLE PROJECTION:							
				DWG NO: SFMRA-089			
				OUTSOURCING: VENDOR			
				SCALE: 1:10		SHEET 111	
				MATERIAL: Rubber		WEIGHT: 150.17 g	
				A4		REVISION: A	

**NOTE:** DEBURR AND BREAK SHARP EDGES ALL BENDS MIN. RADIUS UNLESS SPECIFIED

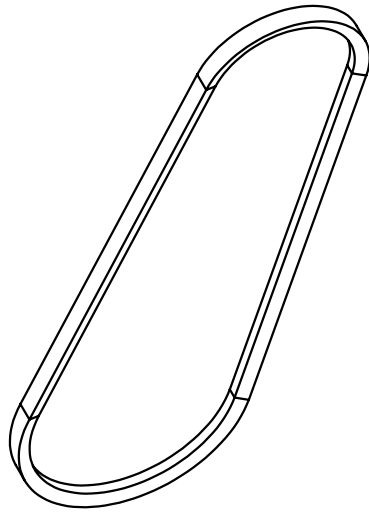

**TYPE B-48  
V-BELT**

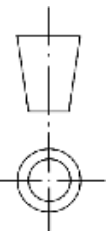
UNLESS OTHERWISE SPECIFIED: STD. TOLERANCE DIMENSIONS ARE IN MILLIMETER MILLIMETER: ±0.1, ANGULAR: ± 0.05° * DOES NOT APPLY TO HOLE SIZE				<b>BANGLADESH RICE RESEARCH INSTITUTE</b> SFMRA PROJECT, FMPHT DIVISION		DO NOT SCALE DRAWING	
DETAILS		NAME	SIGNATURE	DATE	TITLE: BRR I MINI RICE HULLER (BRR RM2024B)		
DRWN	ENGR. SHAFER JAHAN KHAN	S J K		10-MAR-2024	FINISH: NONE		
CHK'D	DR. MD. MOSHARRAF HOSSAIN	M M H		26-MAR-2024	FIRST ISSUED: 17-FEB-2024		
APP'VD	DR. AKMAJIBUL ISLAM	A S I		30-APR-2024	DRG. NAME: V-BELT TYPE-B MODEL: B-48		
THIRD ANGLE PROJECTION:							
NOTE: DEBURR AND BREAK SHARP EDGES ALL BENDS MIN. RADIUS UNLESS SPECIFIED				DWG NO: SFMRA-090			
				OUTSOURCING: VENDOR			
				SCALE: 1:5		SHEET 112	
				MATERIAL: Rubber		WEIGHT: 177.49 g	
				REVISION:		A4	
						A	