

Welcome

Prepared By:



Engr. Pabitra Kumar Halder

Chief Instructor & HoD
(MT)

Barishal Polytechnic Institute

27052-Mechanical Estimating & Costing

Chapter : 1

Semester : 5th

Department : Mechanical

Course : Diploma-in- Engineering

Lesson Declaration

Definition

&

Objectives

**At the end of this lesson
students can--**

- 1. Define Mechanical Estimating**
- 2. Explain importance and objectives of mechanical estimating.**
- 3. Explain function of mechanical estimating.**

Presentation of lesson

Definition of mechanical Estimating :

It is the calculation of a probable cost of an article before the manufacturing starts. It also includes pre-determination of the quality and quantity of material, labour required etc.

Continue

- Estimating requires highly technical knowledge about manufacturing methods and operation times.

Importance of Estimating :

- Accurate estimating is very necessary—
- - to compute the market.
- - to be sure whether the manufacturing of a particular article will be profitable or not.

Both over and under estimating are dangerous. Overestimating leads to increase cost and under estimating may leads to heavy losses to the concern.

Objectives of Estimating

- Deciding the manufacturing and selling policies.
- Filling up the tender enquires.
- Deciding the amount of overheads.
- Deciding the wage rates after time study.
- Deciding whether a particular material should be purchased from the market or to be manufactured.

Function of estimating

- To determine material cost.
- To determine labour cost.
- To determine cost of tools and equipments.
- To determine different overhead charges.
- To determine selling price after adding due profit .

continue

- To conduct Time and Motion study.
- To keep the previous records of estimate in a systematic way for future reference.
- To keep control over selling expenses.
- To find the most economical procedure for manufacturing.
- To help in modification of design.

Evaluation of lesson

ক)

- What do you mean by mechanical estimating?

খ)

- Why both the over and under estimating are dangerous?

গ)

- What are the functions of mechanical estimating?

Home Work



Write down the importance of mechanical estimating for an entrepreneur and submit it on the next class.

Next Class

Explaining of characteristics of a good estimator.

Good Luck



Welcome

Prepared By:



Engr. Pabitra Kumar Halder

Chief Instructor & HoD (MT)

Barishal Polytechnic Institute

27052-Mechanical Estimating & Costing

Chapter : 2

Semester : 5th

Department : Mechanical

Course : Diploma-in- Engineering



UNDERSTAND THE COSTING

Costing:

Cost is defined as "a systematic set of procedures for recording and reporting measurements of the cost of manufacturing goods and performing services in the aggregate and in detail.

Distinguishing between estimating and costing

Difference between Estimating and Costing

Although estimating and costing both are required to decide the price of the product, even then the two are different as explained below:

1. Estimation is aimed to calculate the probable cost of the product before the manufacturing starts, and while costing is the determination of actual cost of the product by adding various elements of expenses incurred.
2. Estimation requires a highly technical knowledge hence an estimator is basically an engineer and costing requires the knowledge of accounts and therefore costing is done by accountants.
3. Estimation forecasts about the probable cost and hence one can know before the manufacture that the manufacturing of the product shall be profitable or not, and whether one should manufacture it or not, but costing tells after the manufacture about the profitability of the product.

Standard cost

- A standard cost is described as a predetermined cost, an estimated future cost, an expected cost, a budgeted unit cost, a forecast cost, or as the "should be" cost. Standard costs are often an integral part of a manufacturer's annual profit plan and operating budgets.

Costing method of materials

1. Unit Costing – If production is made in different grades, costs are ascertained grade wise. Per unit cost is calculated on the basis of units produced. This method is applicable to steel production bricks etc.

2. Job Costing – This method is applicable where work is undertaken to customers. This method is used in repair shops printing press and interior decoration etc.

3. Contract Costing – Unit cost in a contract is of a long duration and it may continue for more than a year. It is most suitable in roads, bridge, shop building etc.

4. Process Costing – The method is used in mass production industries. The raw material passes through a number of processes up to a completion stage.

Costing method of materials

5. Service Costing – This method is used where services are provided such as hotels, cinemas, hospitals, transport etc.

6. Composite Costing – This method is used where a number of components are manufactured separately and then assembled in a final product such as in Scooters, Cars, Air Conditioners etc.

7. Batch Costing – The cost of a batch is ascertained and each batch is a cost unit. This method is used in readymade garments, shoes, and tubes etc.

8. Operation Costing – This system is followed where number of operations are involved.

Three elements that control the cost

- **Materials**
- **Labor**
- **Expenses**

Any Questions?



*Thank
you*



Welcome

Prepared By:



Engr. Pabitra Kumar Halder

Chief Instructor & HoD (MT)

Barishal Polytechnic Institute

27052-Mechanical Estimating & Costing

Chapter : 3

Semester : 5th

Department : Mechanical

Course : Diploma-in- Engineering

UNDERSTAND THE ELEMENTS OF COST

Explain the elements of cost

Materials

1. Direct materials,
2. Indirect materials.

Labor

1. Direct Labour:
2. Indirect Labour

Expense

1. Indirect Expenses,
2. Overhead,
3. Factory Overhead,
4. Administration Overhead.

Explain materials cost and direct and indirect materials

material cost.

- The amount of money invested in the production of a product.

Direct material

- Direct material cost is the cost of the raw materials and components used to create a product.

Indirect Material Cost.

- It is an expense, which is included in Overhead Cost of manufacturing cost, and consists of subsidiary material cost, shop supplies cost, perishable tools and equipment cost.

Direct labor cost

- Direct labor cost is the total cost of employing workers that work directly on a manufacturing product.

Indirect labor

- is the cost of any labor that supports the production process, but which is not directly involved in the active conversion of materials into finished products.

Time study

Time study is a structured process of directly observing and measuring human work using a timing device to establish the time required for completion of the work by a qualified worker when working at a defined level of performance

Motion study

Motion study is a systematic way of determining the best method of doing the work by scrutinizing the motions made by the worker or the machine. As per Gilbreath it is the science of eliminating the wastefulness due to unnecessary motions.

Direct expense

- Direct expense is an expense incurred that varies directly with changes in the volume of a cost object. A cost object is any item for which you are measuring expenses, such as products, product lines, services, sales regions, employees, and customers.

Indirect expense

- Indirect expenses are those expenses that are incurred to operate a business as a whole or a segment of a business, and so cannot be directly associated with a cost object, such as a product, service, or customer.

Fixed overheads

Fixed overhead costs are the same amount every month. These overhead costs do not fluctuate with business activity. Fixed costs include rent and mortgage payments, some utilities, insurance, property taxes, depreciation of assets, annual salaries, and government fees.

Variables overheads

Variable overhead is the cost of operating a business, which fluctuates with manufacturing activity.

As production output increases or decreases, variable overhead moves in tandem. Examples of variable overhead include production supplies, utilities for the equipment, wages for handling, and shipping of the product.

Idleness

Idleness is a lack of motion or energy,

In describing a person or machine, idle means the act of nothing or no work (for example: "John Smith is an idle person").

This is a person who spends his days doing nothing could be said to be "idly passing his days." (For example: Mary has been idle on her instant messenger account for hours.)

Any Questions?



*Thank
you*



Welcome

Prepared By:



Engr. Pabitra Kumar Halder

Chief Instructor & HoD (MT)

Barishal Polytechnic Institute

27052–Mechanical Estimating & Costing

Chapter : 4

Semester : 5th

Department : Mechanical

Course : Diploma–in– Engineering

UNDERSTAND THE COMPONENTS OF COST

Components of cost

The four main components of costs are:

- (a) Prime Cost,
- (b) Works Cost,
- (c) Office Cost and
- (d) Total Cost.

PrimeCost

- ▶ A prime cost is the total direct costs, which may be fixed or variable, of manufacturing an item for sale. Businesses use prime costs as a way of measuring the total cost of the production inputs needed to create a given output.
- ▶ $\text{Prime Cost} = \text{Raw Materials cost} + \text{Direct Labor cost}$.

Works Cost,

Cost of the Work means all costs of completing the Work, including the Contractor's fees, design fees, demolition costs, permit fees and any applicable taxes.

The formula used to calculate costs is $FC + VC(Q) = TC$, where FC is fixed costs, VC is variable costs, Q is quantity, and TC is total cost.

Office cost

- ▶ An expense incurred in controlling and directing an organization, but not directly identifiable with financing, marketing, or production operations. ...
Administrative **costs** are related to the organization as a whole as opposed to expenses related to individual departments. Also called administrative expenses.

Total cost

The formula to calculate total cost is the following:

$$TC \text{ (total cost)} = TFC \text{ (total fixed cost)} + TVC \text{ (total variable cost)}$$

Steps for calculating selling price:

- ▶ Price and Markup. Start with the gross margin percentage your business needs to cover overhead and profit. ...
 - ▶ Find the Cost Percentage of a Good. ...
 - ▶ Compute the Markup Percentage. ...
 - ▶ Set the Price. ...
 - ▶ Choosing Gross Margin Percentage. ...
 - ▶ Informal Pricing: The Tag Sale.
- 

Any Questions?



*Thank
you*



Welcome

Prepared By:



Engr. Pabitra Kumar Halder

Chief Instructor & HoD (MT)

Barishal Polytechnic Institute

27052-Mechanical Estimating & Costing

Chapter : 5

Semester : 5th

Department : Mechanical

Course : Diploma-in- Engineering

Understand the methods of determining depreciation

Depreciation

In accounting terms, depreciation is defined as the reduction of recorded cost of a fixed asset in a systematic manner until the value of the asset becomes zero or negligible.

An example of Depreciation –

If a delivery truck is purchased a company with a cost of Rs. 100,000 and the expected usage of the truck are 5 years, the business might depreciate the asset under depreciation expense as Rs. 20,000 every year for a period of 5 years.

What is the difference between depreciation and obsolescence?

- Depreciation means reduction of value of an asset due to wear and tear. It happens over the life of an asset.
- Obsolescence means reduction of value as the asset is outdated.
- For example, consider a machine with useful life of 10 years. It will be depreciated over the period of 10 years as there will be physical deterioration and wear and tear of the machinery.
- Assume, after 6 years, a new technology has come up, due to which the organization/company no longer use this machinery. Then it is obsolescence.
- Floppy discs and video cassette recorders (VCRs) can be good examples for obsolescence.

Explain the cause of depreciation

1. Wear And Tear

wear and tear refer to a decline in the efficiency of asset due to its constant use. This is true in case of tangible assets like plant and machinery, building, furniture, tools and equipment used in the factory.

2. Effusion Of Time

The value of asset may decrease due to the passage of time even if it is not in use.

- **3. Exhaustion**

An asset may loss its value because of exhaustion too.

4. Obsolescence

Changes in fashion are external factors which are responsible for throwing out of assets even if those are in good condition. For example black and white televisions have become obsolete with the introduction of color TVs,

5. Other Causes

Market value and accident of an asset are other causes of depreciation which decrease in the value of assets.

Different methods of determining depreciation.

The most common depreciation methods include:

- Straight-line.
- Double declining balance.
- Units of production.
- Sum of years digits.
- Sinking fund method.

Straight-line depreciation method

- This is the simplest method of all. It involves simple allocation of an even rate of depreciation every year over the useful life of the asset. The formula for straight line depreciation is:
- Annual Depreciation expense = (Asset cost – Residual Value) / Useful life of the asset
- **Example**
- Suppose a manufacturing company purchases a machinery for Rs. 100,000 and the useful life of the machinery are 10 years and the residual value of the machinery is Rs. 20,000
- **Annual Depreciation expense**
= $(100,000 - 20,000) / 10 = \text{Rs. } 8,000$

Unit of Production method

- This is a two-step process, unlike straight line method. Here, equal expense rates are assigned to each unit produced. This assignment makes the method very useful in assembly for production lines. Hence, the calculation is based on output capability of the asset rather than the number of years.

Unit of Production method

- **Example:** ABC company purchases a printing press to print flyers for Rs. 40,000 with a useful life of 1,80,000 units and residual value of Rs. 4000. It prints 4000 flyers.
-
- **Step 1:** Per unit Depreciation = $(40,000 - 4000) / 180,000 = \text{Rs. } 0.2$
- **Step 2:** Total Depreciation expense = $\text{Rs. } 0.2 * 4000 \text{ flyers} = \text{Rs. } 800$

Double declining method

- This is one of the two common methods a company uses to account for the expenses of a fixed asset. This is an accelerated depreciation method. As the name suggests, it counts expense twice as much as the book value of the asset every year.
- The formula is:
- $\text{Depreciation} = 2 * \text{Straight line depreciation percent} * \text{book value at the beginning of the accounting period.}$

Double declining method

- **Example:**
- On April 1, 2012, company X purchased an equipment for Rs. 100,000. This is expected to have 5 useful life years. The salvage value is Rs. 14,000. Company X considers depreciation expense for the nearest whole month. Calculate the depreciation expenses for 2012, 2013, 2014 using a declining balance method.
- Useful life = 5
- Straight line depreciation percent = $1/5 = 0.2$ or 20% per year
- Depreciation rate = $20\% * 2 = 40\%$ per year
- Depreciation for the year 2012 = $\text{Rs. } 100,000 * 40\% * 9/12 = \text{Rs. } 30,000$
- Depreciation for the year 2013 = $(\text{Rs. } 100,000 - \text{Rs. } 30,000) * 40\% * 12/12 = \text{Rs. } 28,000$
- Depreciation for the year 2014 = $(\text{Rs. } 100,000 - \text{Rs. } 30,000 - \text{Rs. } 28,000) * 40\% * 9/12 = \text{Rs. } 16,800$

The sum of years' digits method

- The sum of years' digits method is a form of accelerated depreciation that is based on the assumption that the productivity of the asset decreases with the passage of time. Under this method, a fraction is computed by dividing the remaining useful life of the asset on a particular date by the sum of the year's digits.

Sinking fund method

- $$D = \frac{R (C-S)}{(1+R)^N - 1}$$

Sinking fund method

1. In order to have Php800,000 in 5 years, Shane deposits an amount each year in a sinking fund earning 6% effective. Find the annual deposit and construct the sinking fund schedule.

$$\begin{aligned} D &= \frac{S_k i_s}{(1 + i_s)^k - 1} \\ &= \frac{(800,000)(.06)}{1.06^5 - 1} \\ &= \text{P}41,917.12 \end{aligned}$$

Any Questions?



Thank
you



Welcome

Prepared By:



Engr. Pabitra Kumar Halder

Chief Instructor & HoD
(MT)

Barishal Polytechnic Institute

27052-Mechanical Estimating & Costing

Chapter : 6

Semester : 5th

Department : Mechanical

Course : Diploma-in- Engineering

Surface Area and Volume

A faint, stylized illustration of a hand holding a pen is visible in the background, rendered in a lighter shade of the teal background color. The hand is positioned as if writing, with the pen tip pointing towards the right.

Day 1 - Surface Area of Prisms

Surface Area = The total area of the surface of a three-dimensional object

(Or think of it as the amount of paper you'll need to wrap the shape.)

Prism = A solid object that has two identical ends and all flat sides.

We will start with 2 prisms – a rectangular prism and a triangular prism.

Rectangular Prism

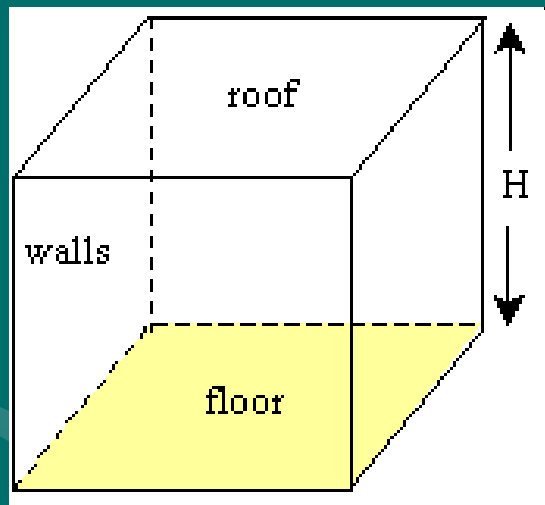

Triangular Prism

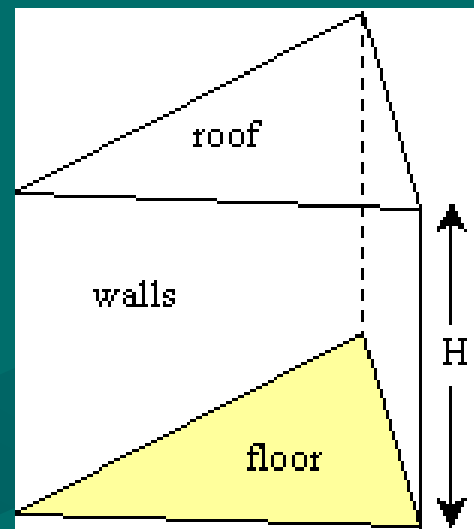

Surface Area (SA) of a Rectangular Prism

Like dice, there are six sides (or 3 pairs of sides)

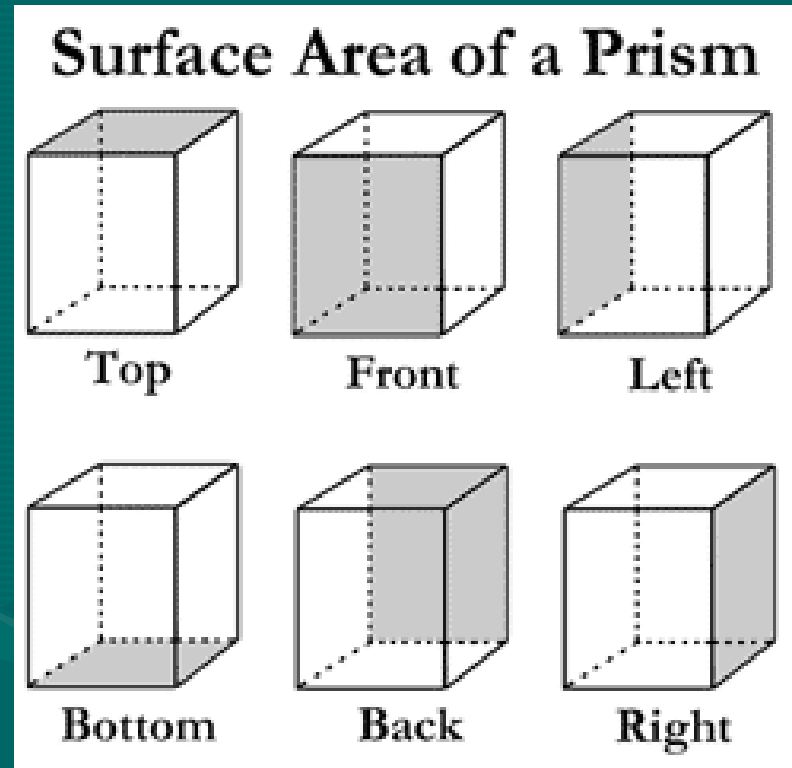

Prism net - unfolded

Rectangular Prism

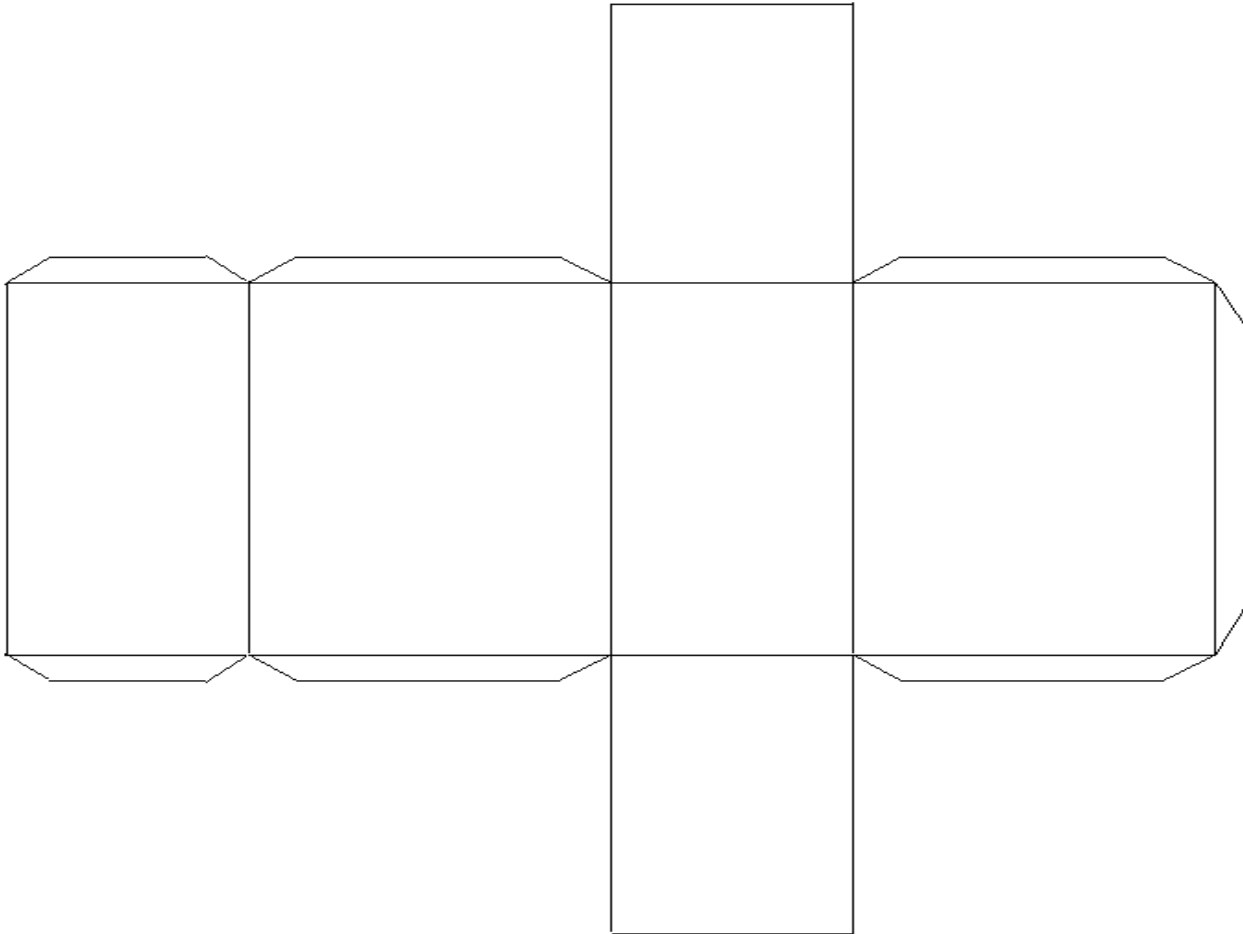

- Add the area of all 6 sides to find the Surface Area.

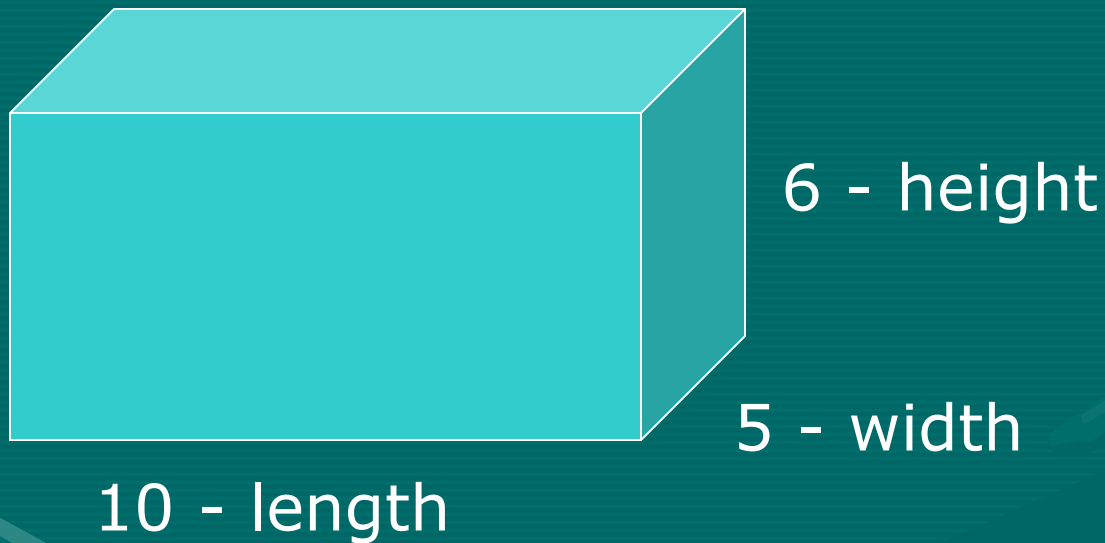

$$SA = 2lw + 2lh + 2wh$$

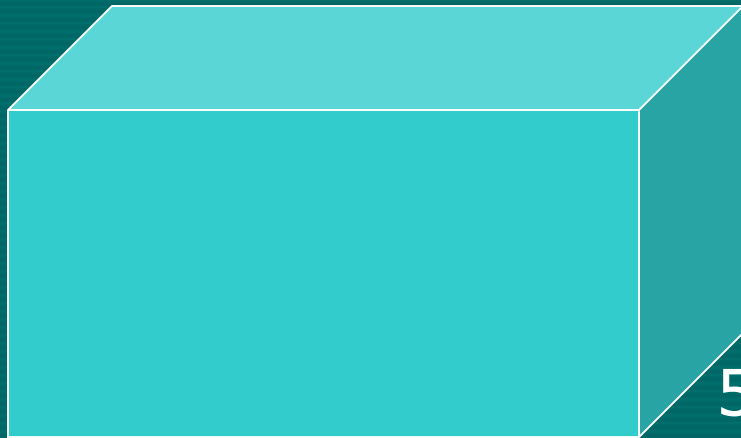

6 - height

5 - width

10 - length

$$SA = 2lw + 2lh + 2wh$$

$$SA = 2(10 \times 5) + 2(10 \times 6) + 2(5 \times 6)$$

$$= 2(50) + 2(60) + 2(30)$$

$$= 100 + 120 + 60$$

$$= 280 \text{ units squared}$$

Practice

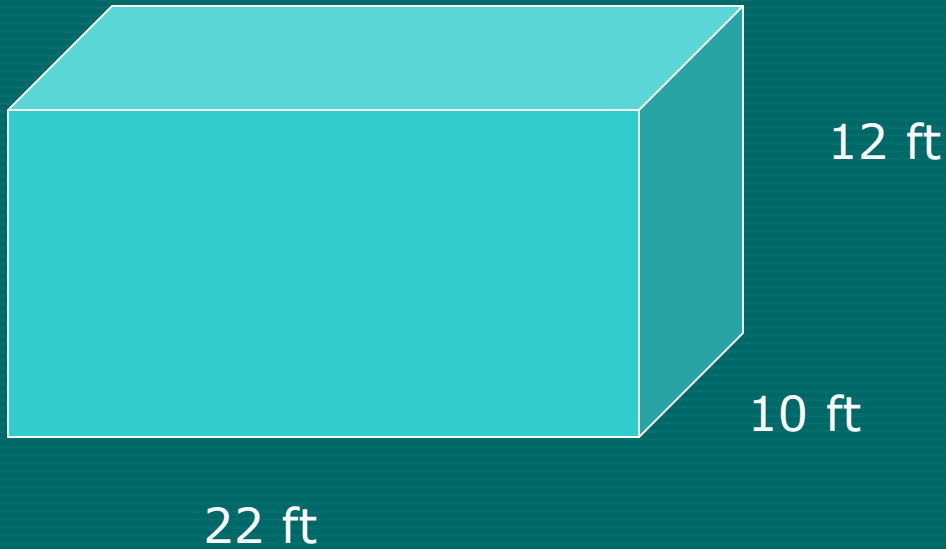

$$\begin{aligned} SA &= 2lw + 2lh + 2wh \\ &= 2(22 \times 10) + 2(22 \times 12) + 2(10 \times 12) \\ &= 2(220) + 2(264) + 2(120) \\ &= 440 + 528 + 240 \\ &= \mathbf{1208 \text{ ft squared}} \end{aligned}$$

Surface Area of a Triangular Prism

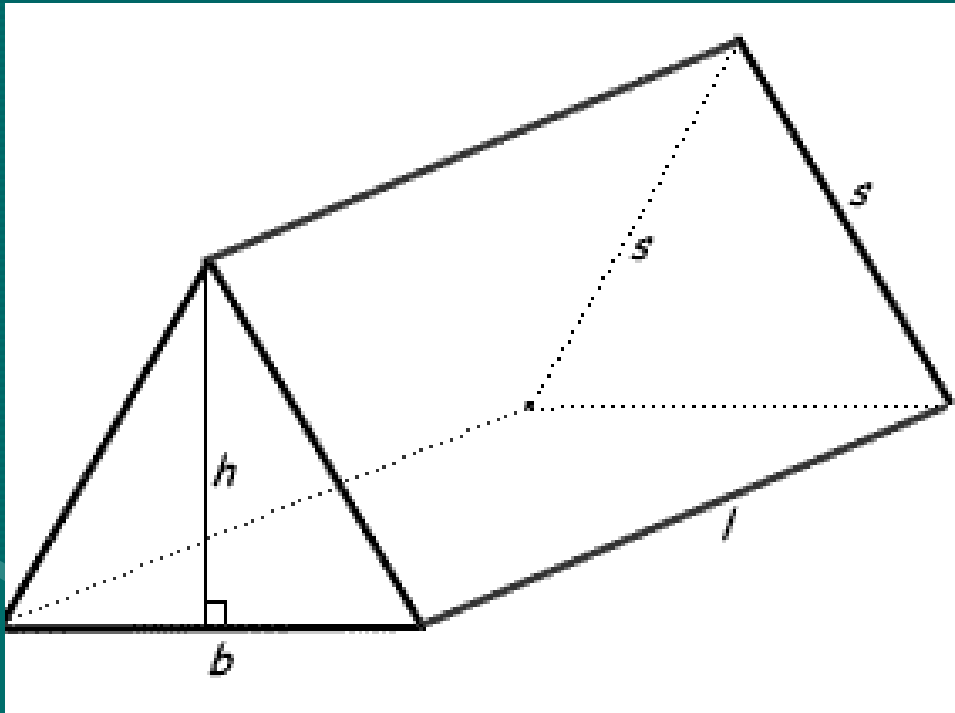

- 2 bases (triangular)
- 3 sides (rectangular)

Unfolded net of a triangular prism

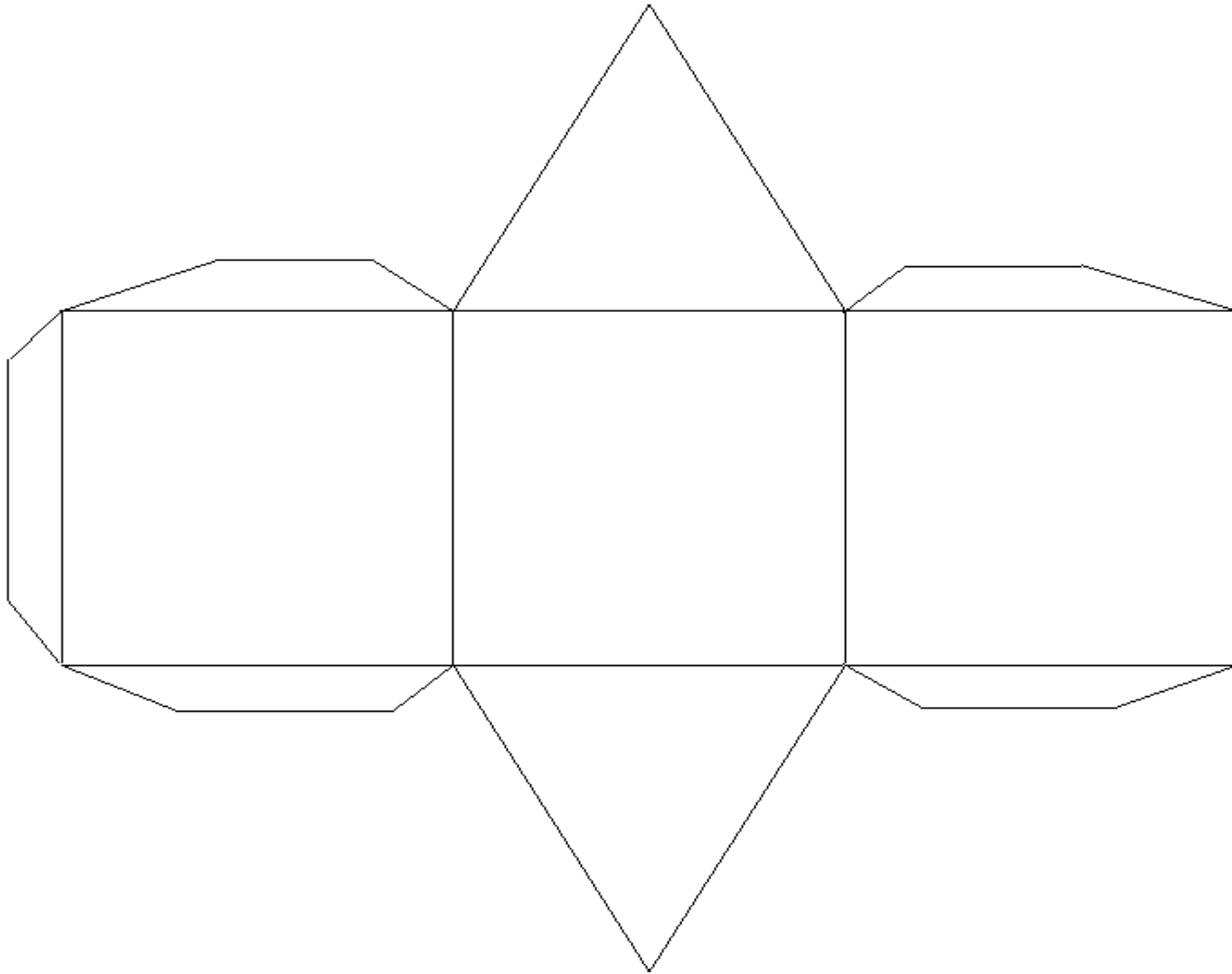

Triangular prism

2(area of triangle) + Area of rectangles

$$\begin{aligned}\text{Area Triangles} &= \frac{1}{2} (b \times h) \\ &= \frac{1}{2} (12 \times 15) \\ &= \frac{1}{2} (180) \\ &= 90\end{aligned}$$

$$\begin{aligned}\text{Area Rect. 1} &= b \times h \\ &= 12 \times 25 \\ &= 300\end{aligned}$$

$$\begin{aligned}\text{Area Rect. 2} &= 25 \times 20 \\ &= 500\end{aligned}$$

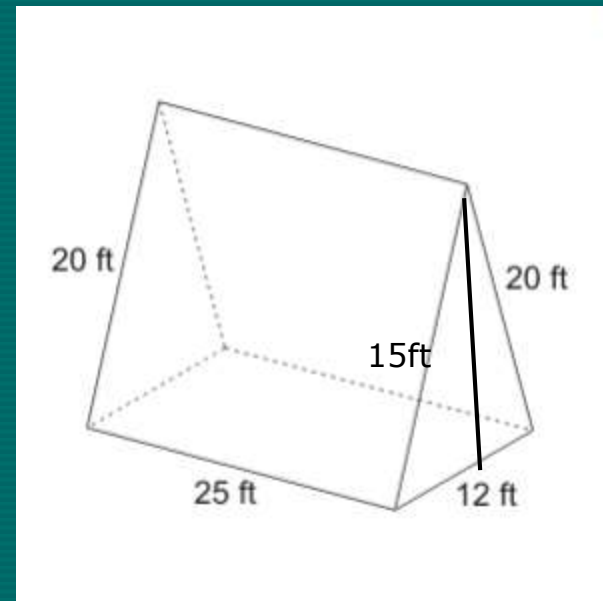

$$\text{SA} = 90 + 90 + 300 + 500 + 500$$

$$\text{SA} = 1480 \text{ ft squared}$$

Practice

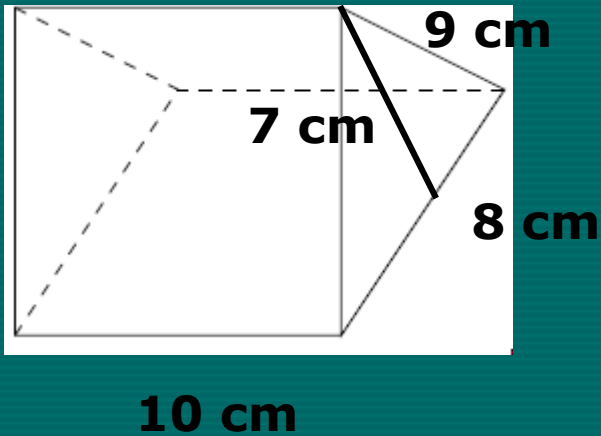

$$\text{Triangles} = \frac{1}{2} (b \times h)$$

$$= \frac{1}{2} (8 \times 7)$$

$$= \frac{1}{2} (56)$$

$$= 28 \text{ cm}$$

$$\text{Rectangle 1} = 10 \times 8$$

$$= 80 \text{ cm}$$

$$\text{Rectangle 2} = 9 \times 10$$

$$= 90 \text{ cm}$$

Add them all up

$$\text{SA} = 28 + 28 + 80 + 90 + 90$$

$$\text{SA} = \mathbf{316 \text{ cm squared}}$$

DAY 2

Surface Area of a Cylinder

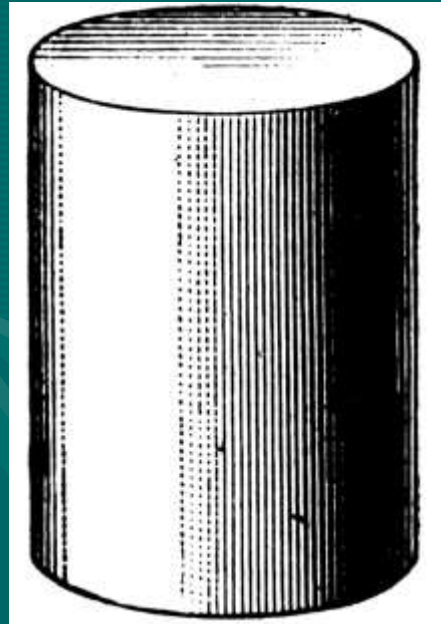

Review

- Surface area is like the amount of paper you'll need to wrap the shape.
- You have to "take apart" the shape and figure the area of the parts.
- Then add them together for the Surface Area (SA)

Parts of a cylinder

A cylinder has 2 main parts.

A **rectangle**

and

A **circle** – well, 2 circles really.

Put together they make a cylinder.

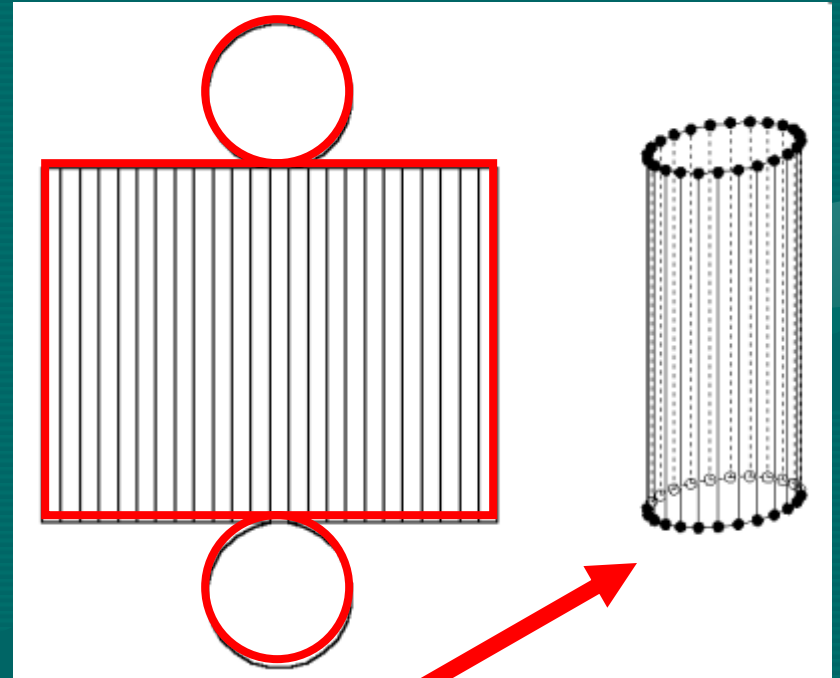

The Soup Can

Think of the Cylinder as a soup can.

You have the top and bottom lid
(**circles**) and you have the label (a
rectangle – wrapped around the
can).

The lids and the label are related.

The circumference of the lid is the
same as the length of the label.



Area of the Circles

Formula for Area of Circle

$$\begin{aligned}A &= \pi r^2 \\ &= 3.14 \times 3^2 \\ &= 3.14 \times 9 \\ &= 28.26\end{aligned}$$

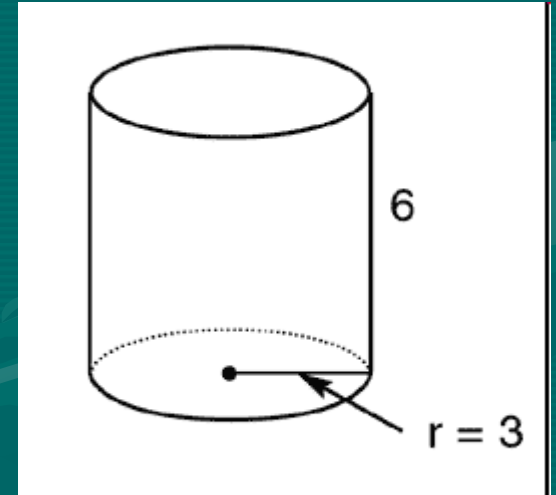

But there are 2 of them so

$$28.26 \times 2 = 56.52 \text{ units squared}$$

The Rectangle

This has 2 steps. To find the area we need base and height. Height is given (6) but the base is not as easy.

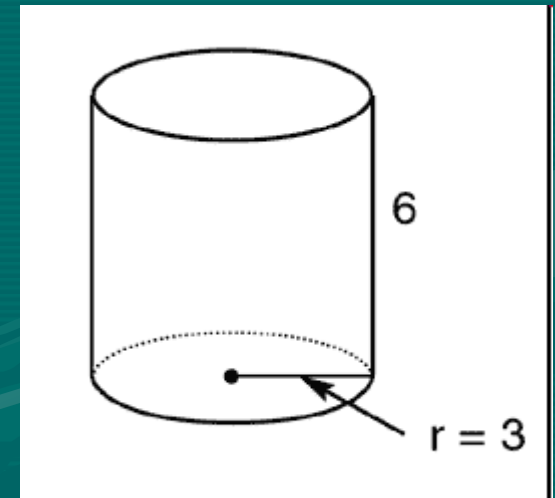

Notice that the base is the same as the distance around the circle (or the Circumference).

Find Circumference

Formula is

$$C = \pi \times d$$

$$= 3.14 \times 6 \text{ (radius doubled)}$$

$$= 18.84$$

Now use that as your base.

$$A = b \times h$$

$$= 18.84 \times 6 \text{ (the height given)}$$

$$= 113.04 \text{ units squared}$$

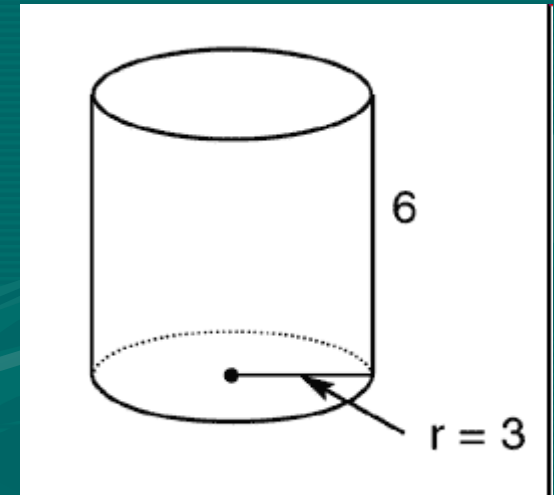

Add them together

Now add the area of the circles and the area of the rectangle together.

$$56.52 + 113.04 = 169.56 \text{ units squared}$$

The total Surface Area!

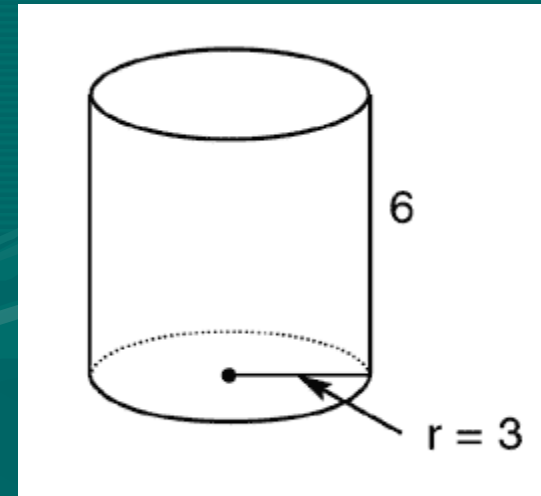

Formula

$$SA = (\pi d \times h) + 2 (\pi r^2)$$

Label

Lids (2)

Area of Rectangle

Area of Circles

Practice

Be sure you know the difference between a radius and a diameter!

$$\begin{aligned} SA &= (\pi d \times h) + 2 (\pi r^2) \\ &= (3.14 \times 22 \times 14) + 2 (3.14 \times 11^2) \\ &= (367.12) + 2 (3.14 \times 121) \\ &= (367.12) + 2 (379.94) \\ &= (367.12) + (759.88) \\ &= \underline{1127 \text{ cm}^2} \end{aligned}$$

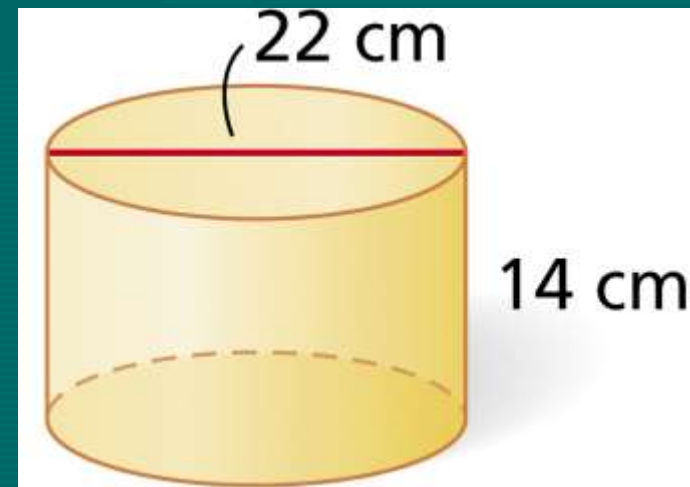

More Practice!

$$\begin{aligned} SA &= (\pi d \times h) + 2 (\pi r^2) \\ &= (3.14 \times 11 \times 7) + 2 (3.14 \times 5.5^2) \\ &= (241.78) + 2 (3.14 \times 30.25) \\ &= (241.78) + 2 (3.14 \times 94.99) \\ &= (241.78) + 2 (298.27) \\ &= (241.78) + (596.54) \\ &= \underline{838.32 \text{ cm}^2} \end{aligned}$$

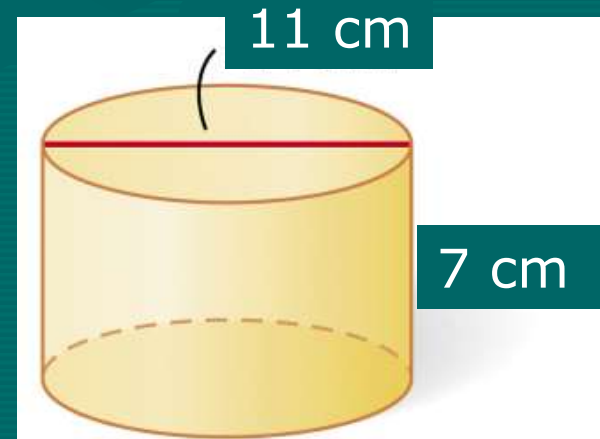

End of Day 2

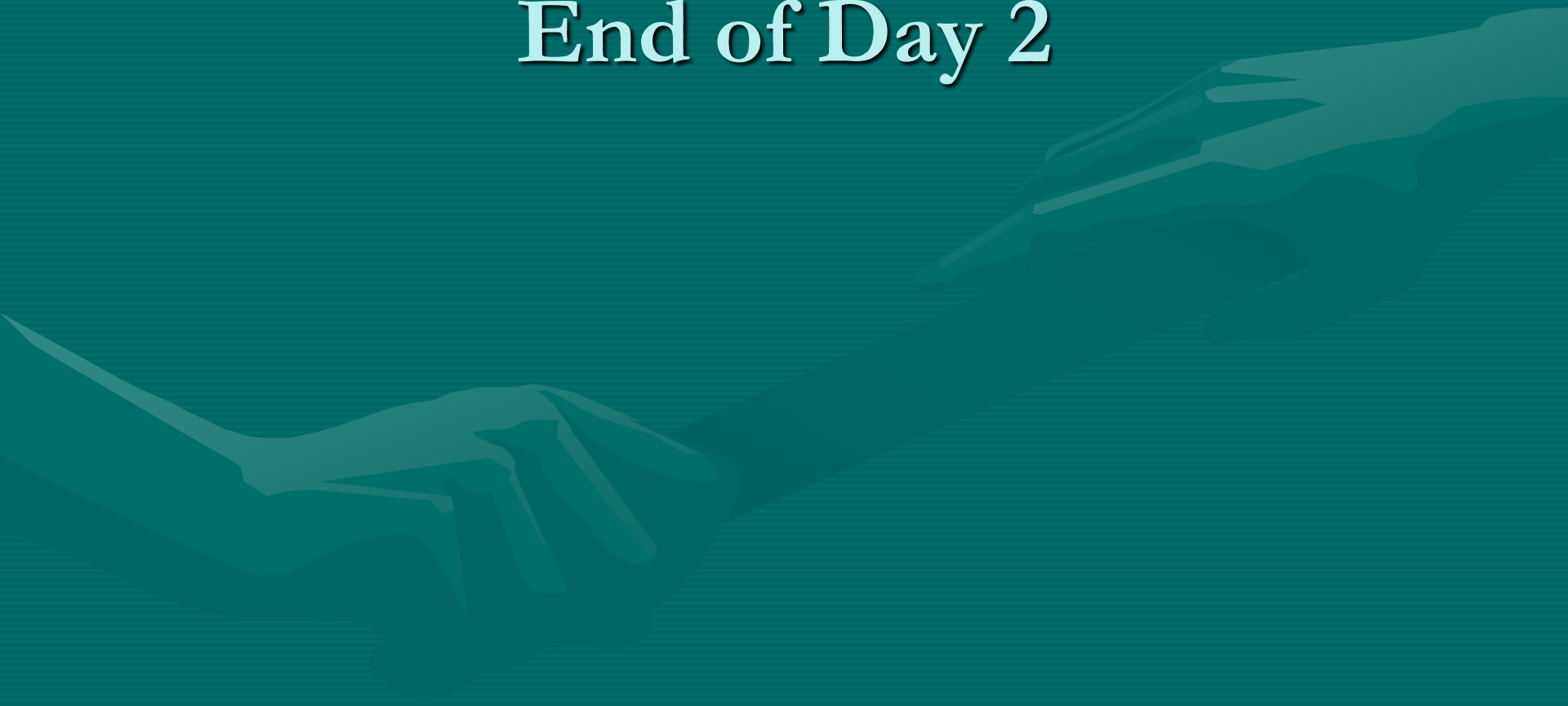

Day 3

Surface Area of a Pyramid

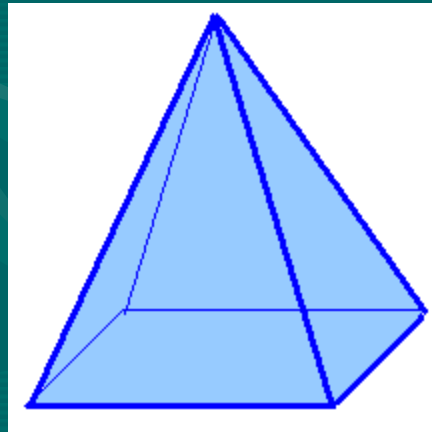

Pyramid Nets

A pyramid has 2
shapes:

One (1) square
&

Four (4) triangles

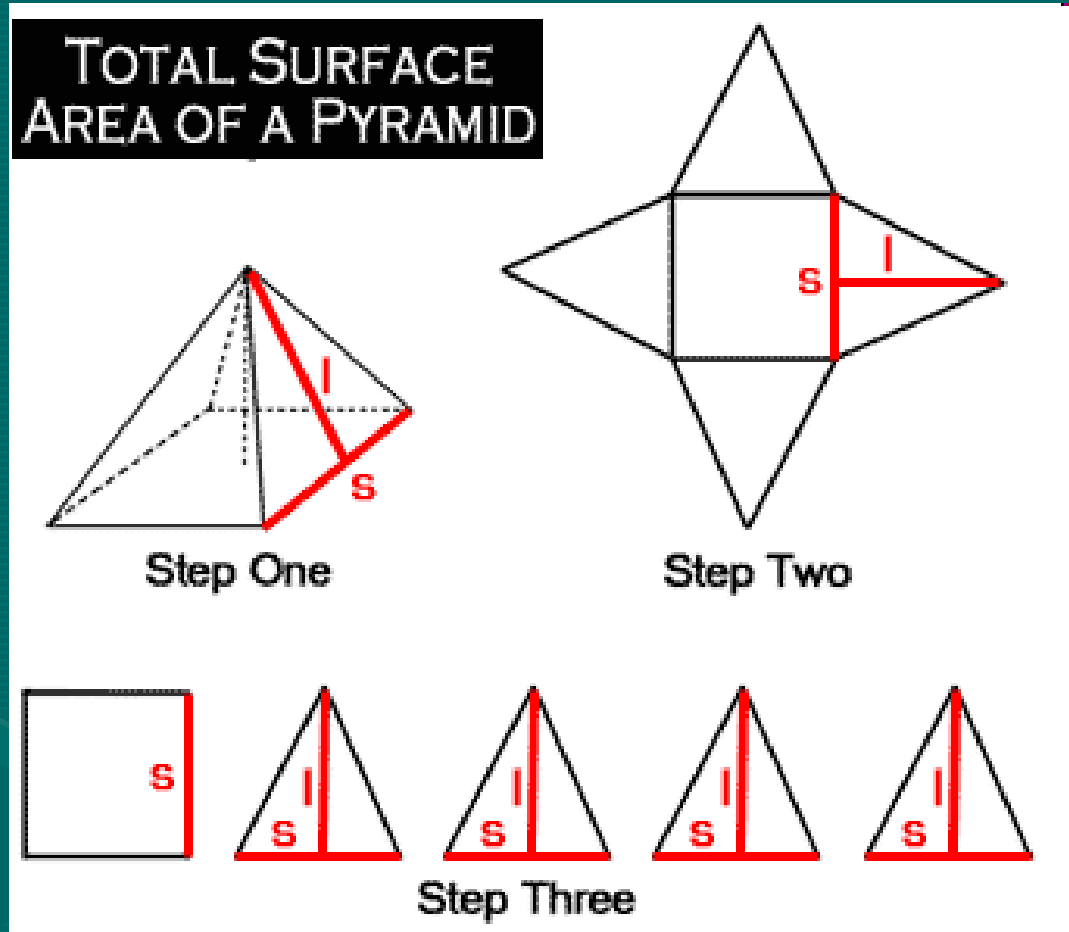

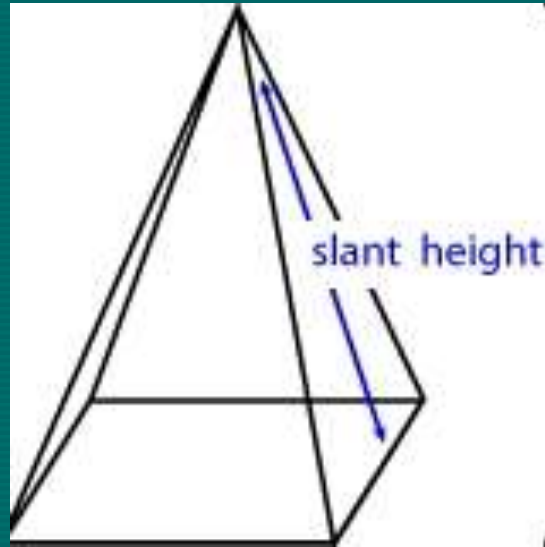

Since you know how to find the areas of those shapes and add them.

Or...

you can use a formula...

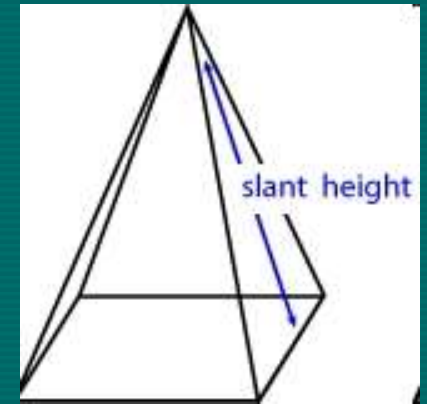

$$SA = \frac{1}{2} lp + B$$

Where l is the Slant Height and

p is the perimeter and

B is the area of the Base

$$SA = \frac{1}{2} lp + B$$

$$\text{Perimeter} = (2 \times 7) + (2 \times 6) = 26$$

$$\text{Slant height } l = 8 ;$$

$$SA = \frac{1}{2} lp + B$$

$$= \frac{1}{2} (8 \times 26) + (7 \times 6)$$

$$= \frac{1}{2} (208) + (42)$$

$$= 104 + 42$$

$$= \underline{146 \text{ units}^2}$$

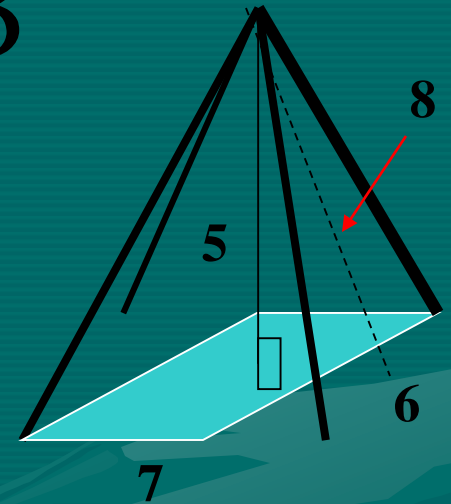

area of the base

Practice

$$SA = \frac{1}{2} lp + B$$

$$= \frac{1}{2} (18 \times 24) + (6 \times 6)$$

$$= \frac{1}{2} (432) + (36)$$

$$= 216 + 36$$

$$= \underline{252 \text{ units}^2}$$

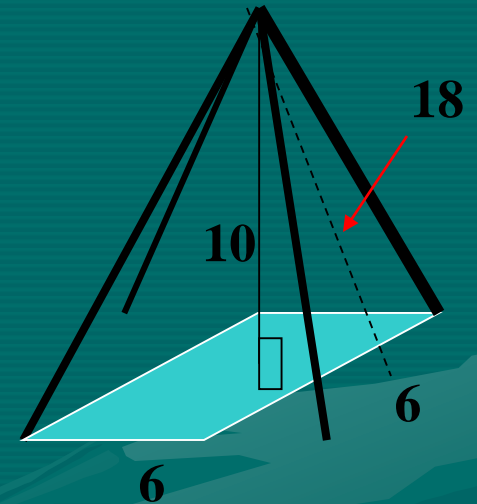

Slant height = 18

Perimeter = $6 \times 4 = 24$

What is the extra information in the diagram?

End Day 3



Day 4

Volume of Prisms and Cylinders

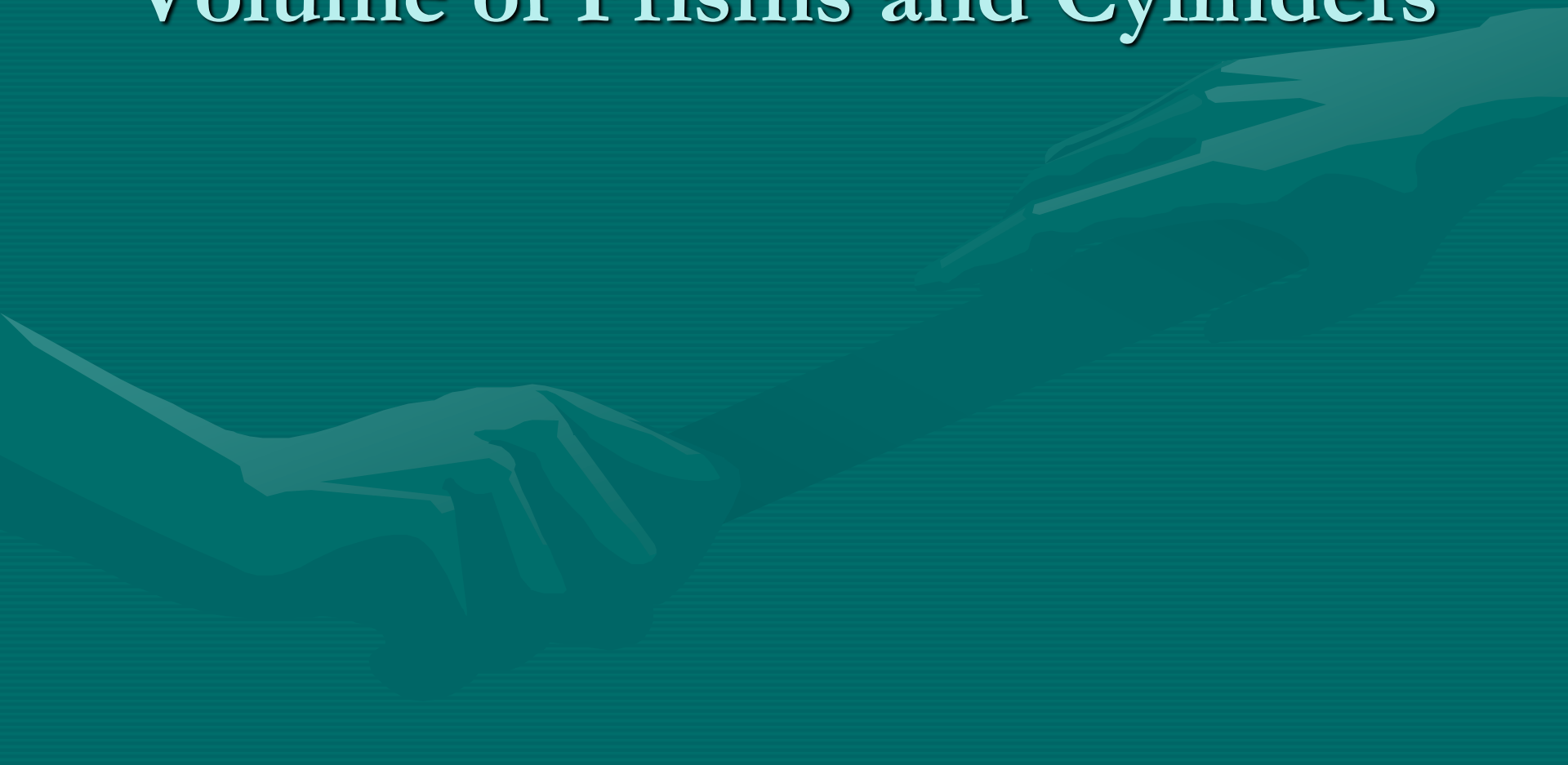

Volume

- The number of cubic units needed to fill the shape.

Find the volume of this prism by counting how many cubes tall, long, and wide the prism is and then multiplying.

- There are 24 cubes in the prism, so the volume is 24 cubic units.

$$2 \times 3 \times 4 = 24$$

2 – height

3 – width

4 – length

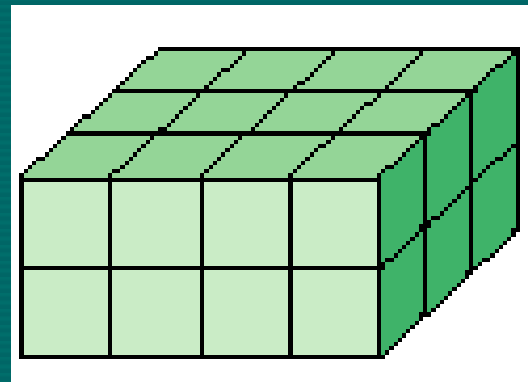

Formula for Prisms

VOLUME OF A PRISM

The volume V of a prism is the area of its base B times its height h .

$$V = Bh$$

Note – the capital letter stands for the AREA of the BASE not the linear measurement.

Try It

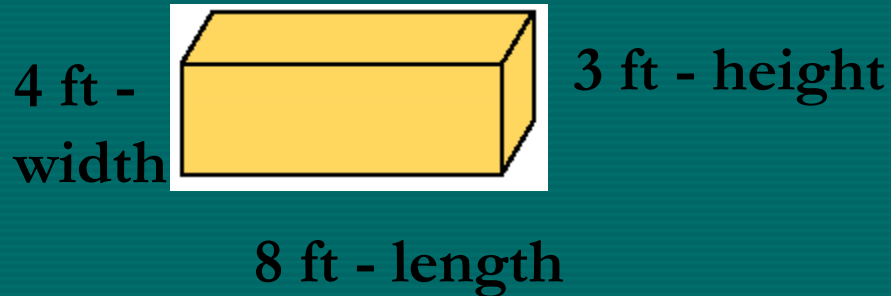

$$V = Bh$$

Find area of the base

$$= (8 \times 4) \times 3$$

$$= (32) \times 3$$

Multiply it by the height

$$= \underline{96 \text{ ft}^3}$$

Practice

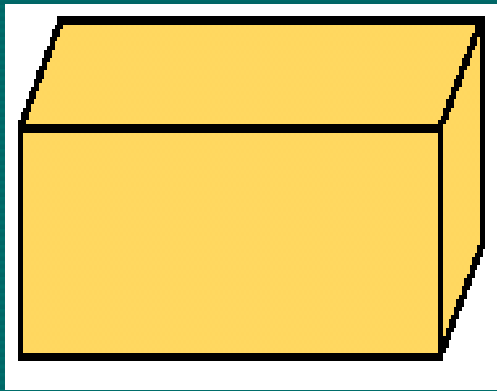

22 cm

12 cm

10 cm

$$\begin{aligned} V &= Bh \\ &= (22 \times 10) \times 12 \\ &= (220) \times 12 \\ &= \underline{2640 \text{ cm}^3} \end{aligned}$$

Cylinders

VOLUME OF A CYLINDER

The volume V of a cylinder is the area of its base, πr^2 , times its height h .

$$V = \pi r^2 h$$

Notice that πr^2 is the formula for area of a circle.

Try It

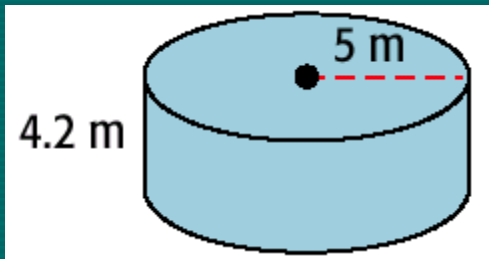

$$V = \pi r^2 h$$

The radius of the cylinder is 5 m, and the height is 4.2 m

$$V = 3.14 \cdot 5^2 \cdot 4.2$$

Substitute the values you know.

$$V = \underline{329.7}$$

Practice

13 cm - radius



7 cm - height

$$V = \pi r^2 h$$

Start with the formula

$$V = 3.14 \times 13^2 \times 7$$

Substitute what you know

$$= 3.14 \times 169 \times 7$$

Solve using order of Ops.

$$= \underline{3714.62 \text{ cm}^3}$$

Lesson Quiz

Find the volume of each solid to the nearest tenth. Use 3.14 for π .

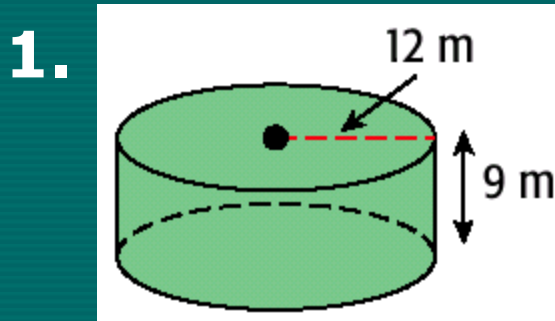

$$4,069.4 \text{ m}^3$$

2.

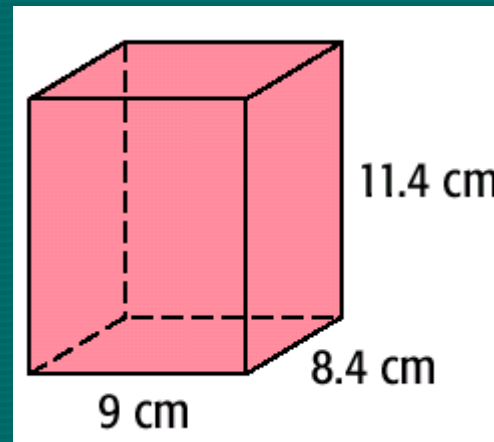

$$861.8 \text{ cm}^3$$

3. triangular prism: base area = 24 ft^2 , height = 13 ft
 312 ft^3

End of Day 4



Day 5

Volume of Pyramids

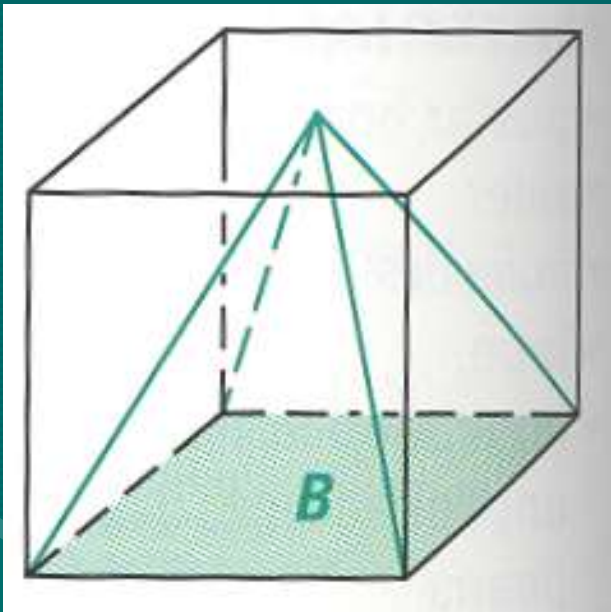

Remember that Volume of a Prism is $B \times h$ where b is the area of the base.

You can see that Volume of a pyramid will be less than that of a prism.

How much less? Any guesses?

If you said $2/3$ less, you win!

Volume of a Pyramid:

$V = (1/3)$ Area of the Base \times height

$V = (1/3) Bh$

Volume of a Pyramid = $1/3 \times$ Volume of a Prism

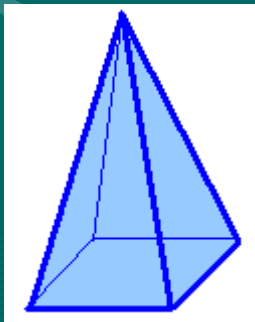

+

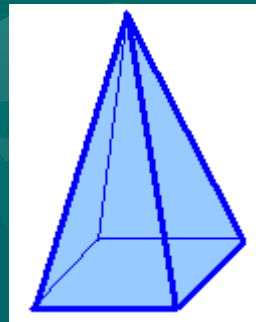

+

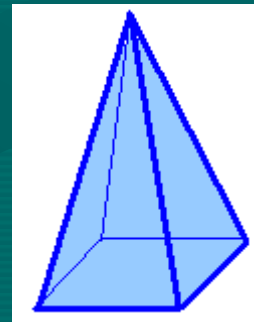

=

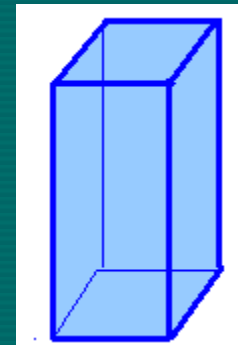

Find the volume of the square pyramid with base edge length 9 cm and height 14 cm.

The base is a square with a side length of 9 cm, and the height is 14 cm.

$$\begin{aligned} V &= \frac{1}{3} Bh \\ &= \frac{1}{3} (9 \times 9)(14) \\ &= \frac{1}{3} (81)(14) \\ &= \frac{1}{3} (1134) \\ &= \underline{378 \text{ cm}^3} \end{aligned}$$

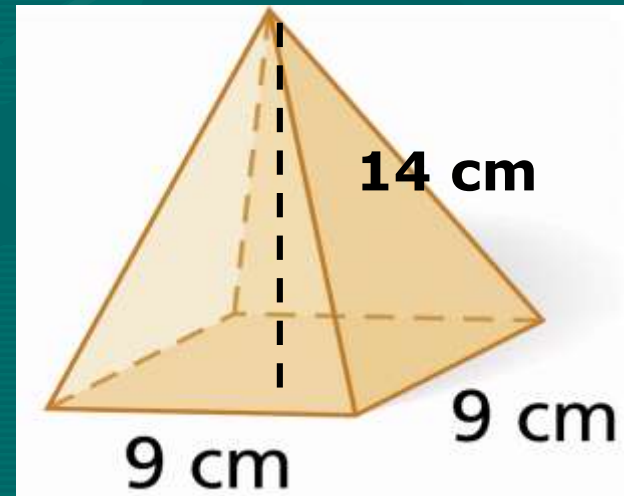

Practice

$$\begin{aligned} V &= \frac{1}{3} Bh \\ &= \frac{1}{3} (5 \times 5) (10) \\ &= \frac{1}{3} (25)(10) \\ &= \frac{1}{3} 250 \\ &= \underline{83.33 \text{ units}^3} \end{aligned}$$

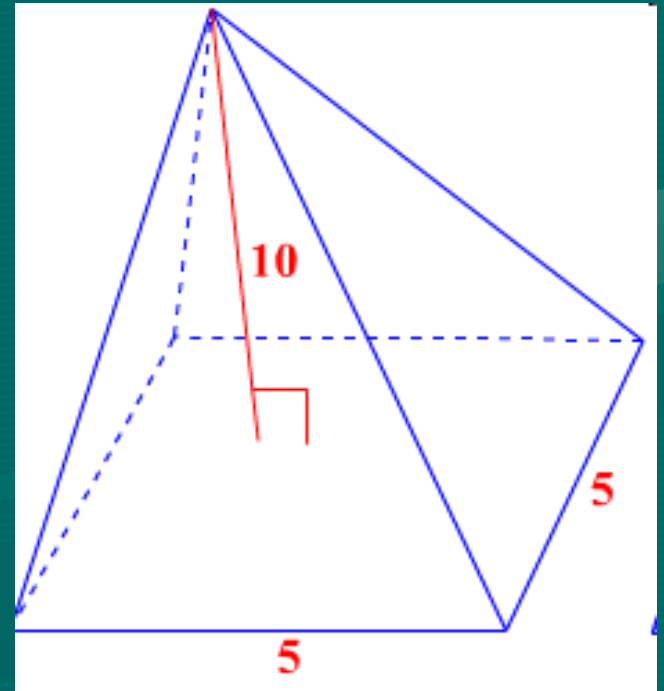

STEPS OF DETERMINING VOLUME AND WEIGHT OF ENGINEERING PARTS

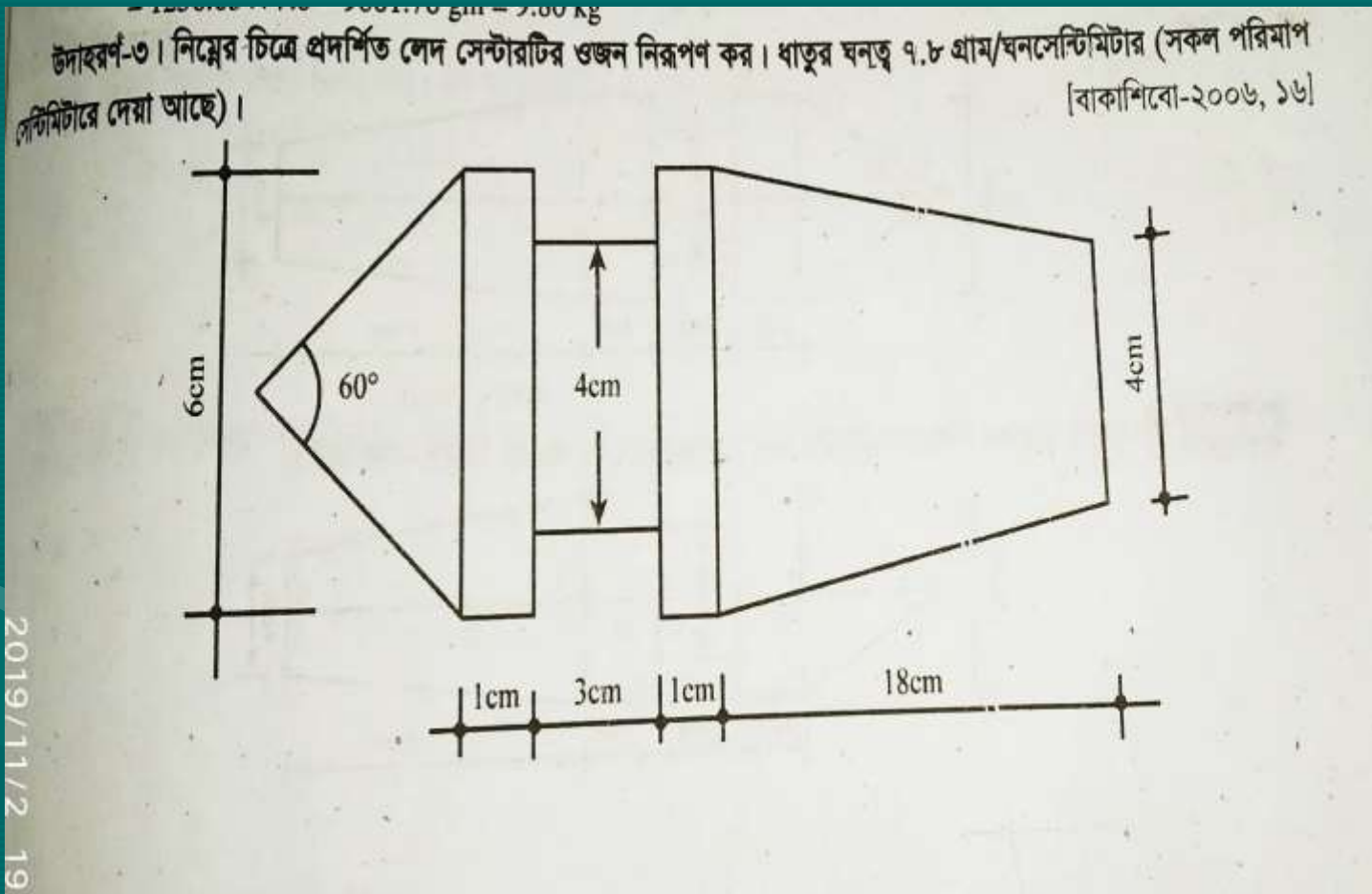

DETERMENT AREA AND VOLUME OF DIFFERENT ENGINEERING PARTS

উদাহরণ-১২। চিত্রে প্রদর্শিত বস্তুটির আয়তন নির্ণয় কর।

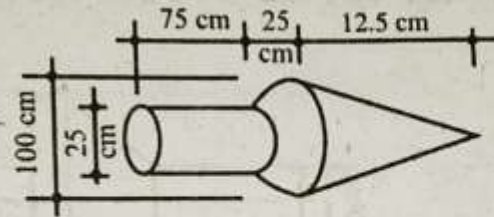

সমাধান। প্রথমে আয়তন নির্ণয়ের সুবিধার জন্য আলাদাভাবে অংশগুলো চিহ্নিত করে নিই।

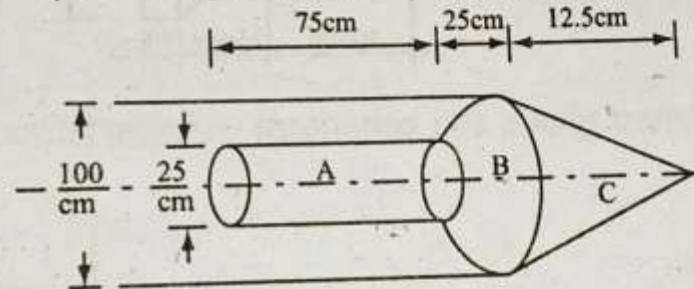

$$A \text{ অংশের আয়তন, } = \frac{\pi \times D^2}{4} \times L = \frac{\pi \times 25^2}{4} \times 75 = 36816.53 \text{ cm}^3$$

$$B \text{ অংশের আয়তন, } = \frac{\pi h}{3} (R^2 + r^2 + R.r) = \frac{\pi \times 25}{3} (50^2 + 12.5^2 + 50 \times 12.5) = 85902.92 \text{ cm}^3$$

$$C \text{ কোণকের আয়তন, } = \frac{1}{3} \pi r^2 L = \frac{1}{3} \times \pi \times (50)^2 \times 12.5 = 327249.23 \text{ cm}^3$$

$$\therefore \text{ মোট আয়তন } = A + B + C = 36815.53 + 85902.92 + 327249.23 = 449967.68 \text{ cm}^3$$

Quiz

Find the volume of each figure.

1. a rectangular pyramid with length 25 cm, width 17 cm, and height 21 cm

2975 cm^3

2. a triangular pyramid with base edge length 12 in. a base altitude of 9 in. and height 10 in.

360 in^3

End of Day 5

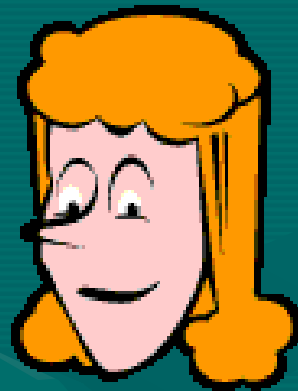

Welcome

Prepared By:



Engr. Pabitra Kumar Halder

Chief Instructor & HoD (MT)

Barishal Polytechnic Institute

27052-Mechanical Estimating & Costing

Chapter : 7

Semester : 5th

Department : Mechanical

Course : Diploma-in- Engineering

UNDERSTAND THE METHODS OF
ESTIMATION OF FITTING SHOP

Estimate the material cost of divider, wrench ,
bucket, funnel,mug

Estimate the material cost of funnel

ফাটং শপের জবের প্রাক্কলন

উদাহরণ-৭। চিত্র অনুযায়ী 20 গেজি জি.আই শিট হতে একটি ফানেল তৈরি করতে শিটের পরিমাণ ও মূল্য নির্ণয় কর।
এক্ষেত্রে শিটের অপচয় 10% এবং প্রতি বর্গমিটার শিটের মূল্য 200 টাকা।

[বাকশিবো-২০১৩, ১৬]

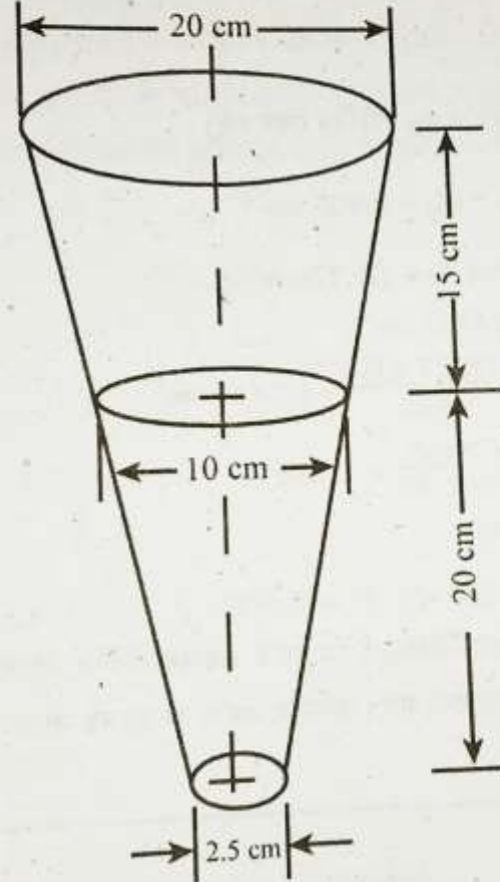

Estimate the material cost of divider

ডিভাইডার (Divider) :

প্রয়োজনীয় মালামাল :

(i) পা তৈরি করার জন্য প্রয়োজনীয় একখণ্ড ইস্পাত দ্রব্যের পরিমাপ
= $2.5\text{cm} \times 0.64\text{cm} \times 16.25\text{cm}$.

(ii) জোড়ার জন্য একটি ইস্পাতের রিভেট

পা তৈরির পদার্থের পরিমাপ

= $(2.5 \times 0.64 \times 16.25) = 26\text{ cm}^3$

কাটার জন্য মোট মালামালের ৫% অতিরিক্ত ধরলে

সর্বমোট মালামাল এর আয়তন

= $26 \times \frac{105}{100} = 27.3\text{cm}^3$

প্রতি ঘন সেমি ইস্পাতের ওজন = 7.8 গ্রাম হলে

মোট ওজন = আয়তন \times ঘনত্ব

= $27.3 \times 7.8 = 213\text{ gm}$.

1 কেজি বা 1000 মস ইস্পাতের মূল্য 20 টাকা হলে

মোট মূল্য = $\frac{213 \times 20}{1000} = 4.26$ টাকা।

একটি 0.50 সেমি ব্যাস এবং 1.25 cm লম্বা একটি এমএস রিভেটের আনুমানিক মূল্য = 0.14 টাকা

\therefore মোট প্রয়োজনীয় মালামালের মূল্য = $4.26 + 0.14 = 4.40$ টাকা।

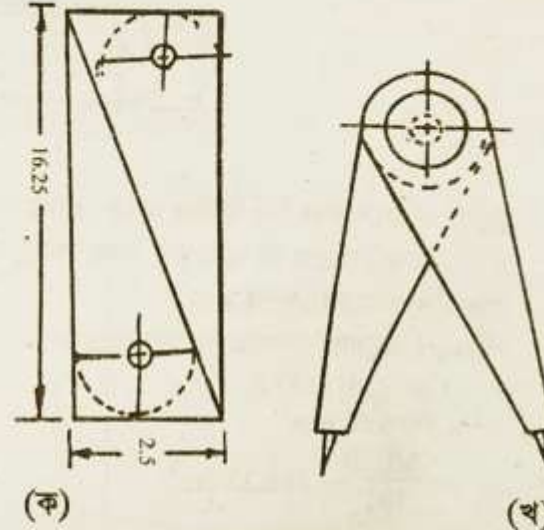

চিত্র : ডিভাইডার

Estimate the material cost of wrench

(খ) রেঞ্চ (Wrench) :

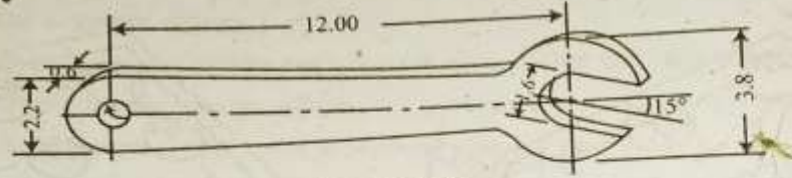

চিত্র : ৭.১১ রেঞ্চ

● রেঞ্চ এর প্রয়োজনীয় মালামাল খরচ নির্ণয় :

চিত্র অনুযায়ী একটি রেঞ্চ তৈরি করতে $3.8 \times 0.6 \times 15$ (সেমি) এর একটি ইস্পাতের পাত প্রয়োজন। উক্ত পাতের মোট আয়তন

$$= 3.8 \times 0.6 \times 15 = 34.20 \text{ ঘন সেমি}$$

প্রতি ঘন সেমি ইস্পাতের ওজন 7.8 গ্রাম ধরে মোট ওজন

$$= 34.20 \times 7.8 = 266.76 \text{ গ্রাম}$$

প্রতি কেজি ইস্পাতের মূল্য 15.00 টাকা হলে 266.76 গ্রাম ইস্পাতের মূল্য

$$= 4.00 \text{ টাকা।}$$

মজুরি বাবদ খরচ নির্ণয় (Labour cost) :

মজুরি ব্যয় প্রত্যক্ষ মালামাল খরচের 20% ধরলে মোট মজুরি খরচের পরিমাণ

$$= 4.00 \times \frac{20}{100} = 0.80 \text{ টাকা}$$

অন্যান্য খরচ নির্ণয় :

অন্যান্য খরচ প্রত্যক্ষ মালামাল খরচের 10% ধরে মোট অন্যান্য খরচ

$$= 4 \times \frac{10}{100} = 0.40 \text{ টাকা।}$$

রেঞ্চ এর মোট উৎপাদন ব্যয় নির্ণয় :

মোট উৎপাদন ব্যয় = প্রত্যক্ষ মালামাল খরচ + মজুরি + অন্যান্য খরচ

$$= 4.00 + 0.80 + 0.40 = 5.20 \text{ টাকা}$$

Estimate the material cost of mug

(ঙ) মগ (Mug) :

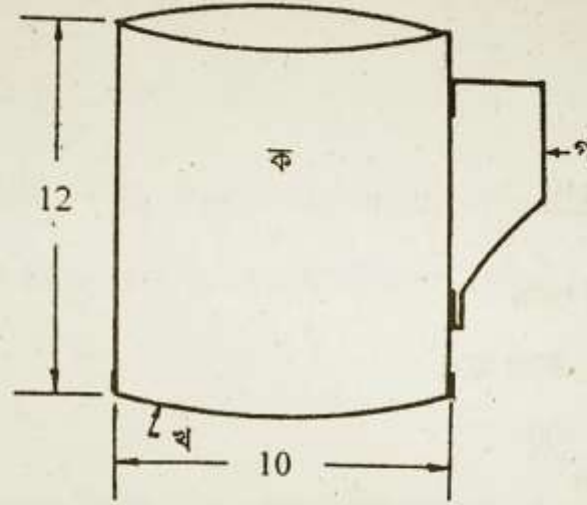

চিত্র : ৭.১৯ মগ

মগের জন্য প্রয়োজনীয় মালামালের মূল্য নিরূপণ :

মগটি 28 গেজি জি.আই শিট দ্বারা প্রস্তুত করতে হবে। একটি মগ প্রস্তুত করতে নিম্নলিখিত মালামাল প্রয়োজন।

-জি.আই শিট,

- রিভেট

Formula of total cost

- The formula to calculate total cost is the following:
- $TC \text{ (total cost)} = TFC \text{ (total fixed cost)} + TVC \text{ (total variable cost)}$.



*Thank
you*



Welcome

Prepared By:



Engr. Pabitra Kumar Halder

Chief Instructor & HoD (MT)

Barishal Polytechnic Institute

27052-Mechanical Estimating & Costing

Chapter : 8

Semester : 5th

Department : Mechanical

Course : Diploma-in- Engineering

UNDERSTAND THE METHODS OF ESTIMATION OF MACHINE SHOP JOB

Estimate the material cost of

1. Ball peen hammer,
2. Vee-block,
3. Center punch

Ball peen hammer

Find the material cost of below ball peen hammer

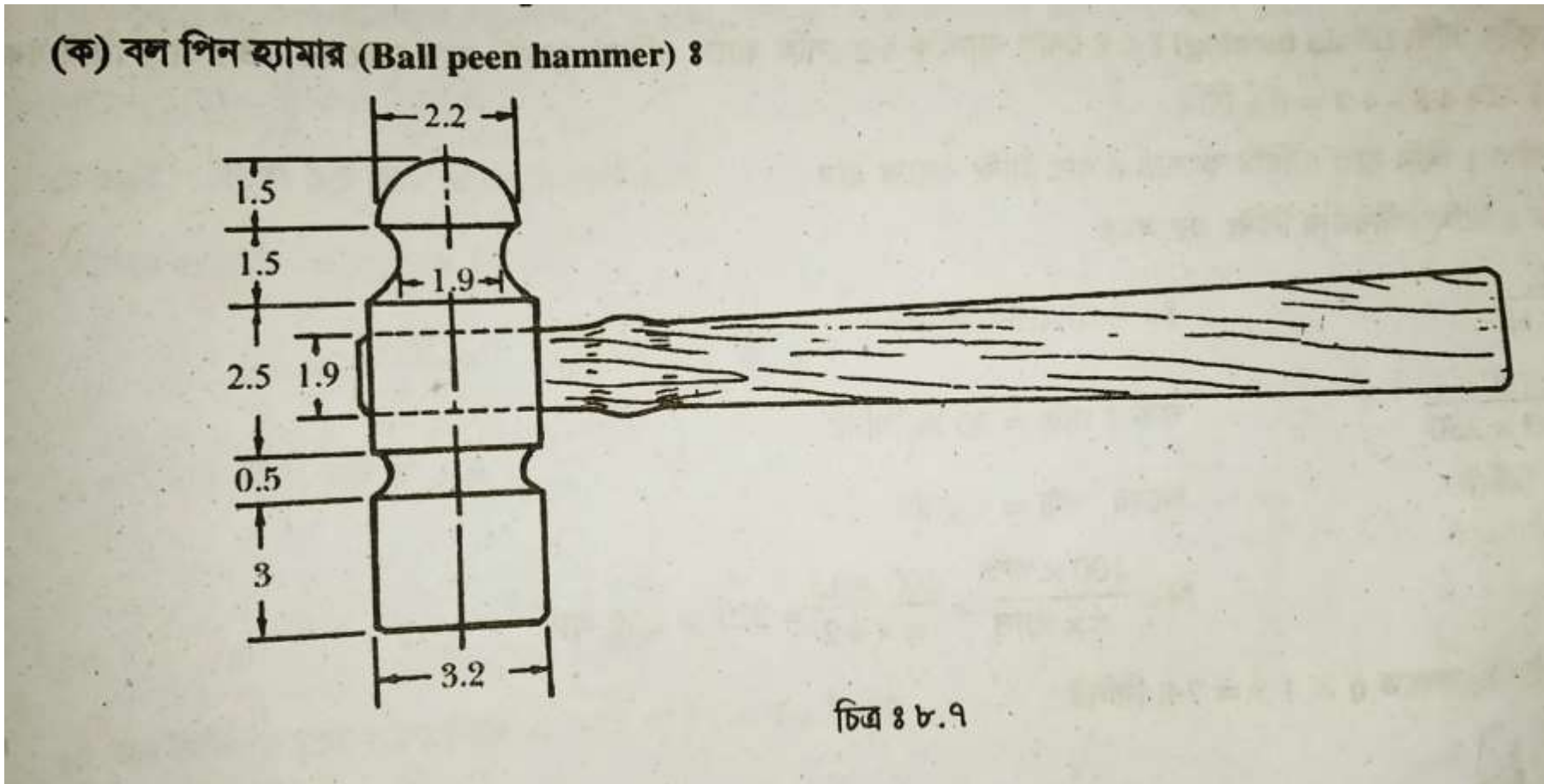

Vee-block

Find the material cost of below vee-block

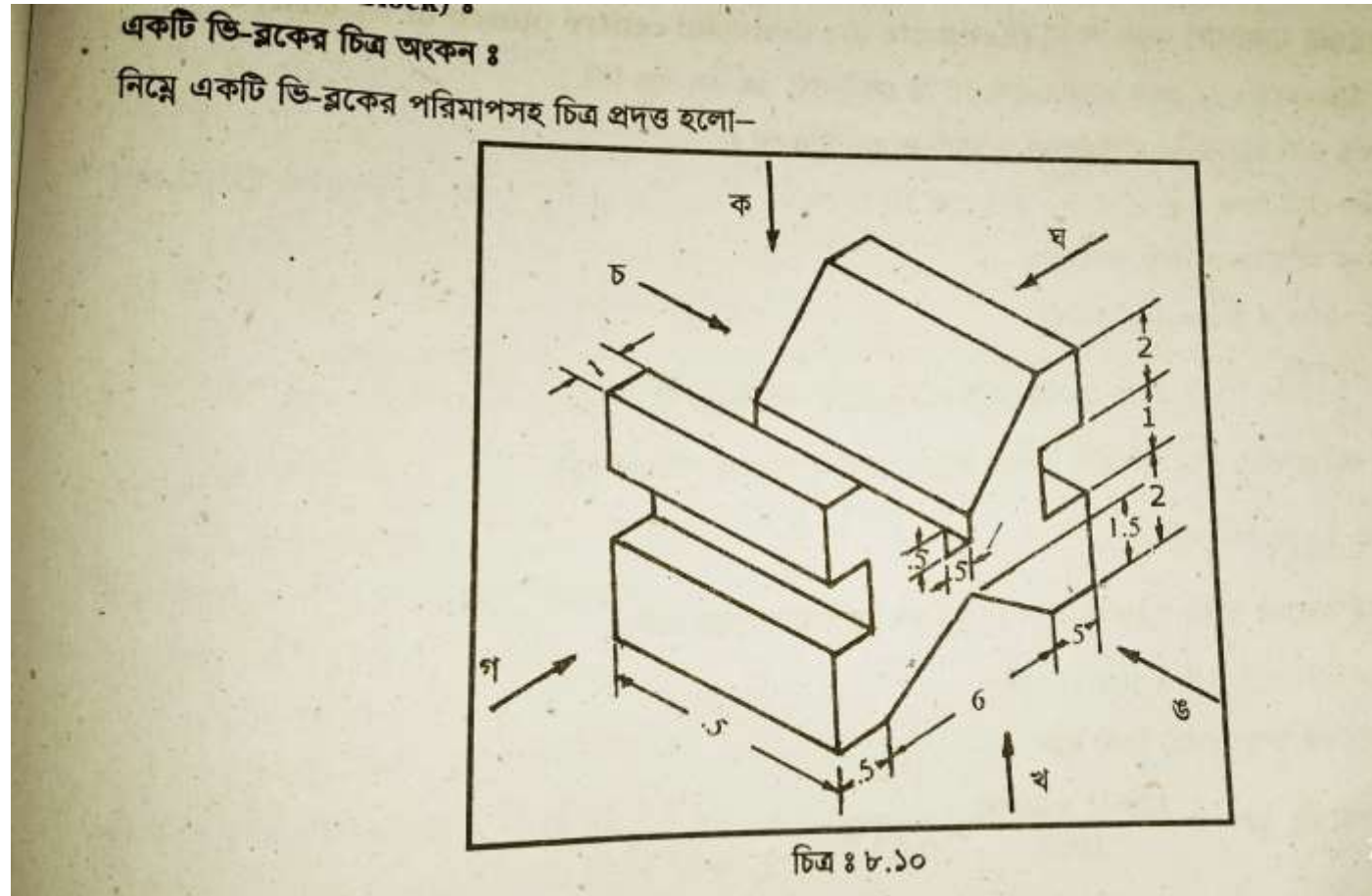

Center punch

Find the material cost of below center punch

প্রশ্ন-১০। নিম্নের চিত্রে প্রদত্ত সেন্টার পাঞ্চ তৈরির মজুরি ও সময় ব্যয় নিরূপণ কর।

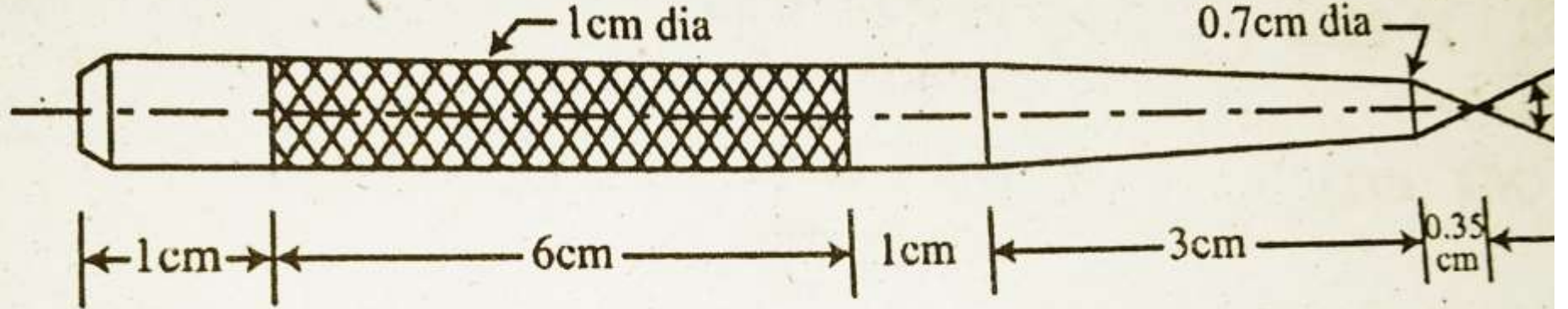

সেন্টার পাঞ্চের মালামাল খরচ নির্ণয় (Estimate the material centre punch)

Estimate the labor cost of the job

- Estimating labor costs
- Determining the Construction Labor Cost
- Crew's hourly rate X 3 (amount of workers) X 6 (number of weeks) X 40 (hours per week) = Cost of the project. This formula will give you the labor cost of a project for your crew.

Estimate the over head

- Calculate the overhead rate, divide the indirect costs by the direct costs and multiply by 100. If your overhead rate is 20%, it means the business spends 20% of its revenue on producing a good or providing services. A lower overhead rate indicates efficiency and more profits.

How to determine the total cost of the job?

- $(\text{Average fixed cost} + \text{Average variable cost}) \times \text{Number of units} = \text{Total cost}.$
- For example, a company is incurring \$10,000 of fixed costs to produce 1,000 units (for an average fixed cost per unit of \$10), and its variable cost per unit is \$3. At the 1,000-unit production level, the total cost of the production is:
- $(\$10 \text{ Average fixed cost} + \$3 \text{ Average variable cost}) \times 1,000 \text{ Units} = \$13,000 \text{ Total cost}$

Any Questions?



Thank
you



Welcome

Prepared By:



Engr. Pabitra Kumar Halder

Chief Instructor & HoD (MT)

Barishal Polytechnic Institute

27052-Mechanical Estimating & Costing

Chapter : 9

Semester : 5th

Department : Mechanical

Course : Diploma-in- Engineering

UNDERSTAND THE METHODS OF ESTIMATION OF WELDING SHOP JOB

Estimate the material cost of,

- 1.Lap welding job,
- 2.Butt welding job,
- 3.Pipe welding job.

Estimate the material cost of

Lap welding job

নিম্নে ল্যাপ, বাট এবং পাইপ ওয়েল্ডিং এর মালামাল খরচ, শ্রম বাবদ খরচ, উপরি খরচ, মোট ব্যয় নির্ণয় পদ্ধতি উদাহরণের মাধ্যমে দেখানো হলো।

উদাহরণ-১। দুটি ৪০ মিমি লম্বা ৬ মিমি পুরুত্ব এম.এস গ্রেটকে ল্যাপ জোড় দিতে হবে। [বাকাশিবো-২০১৩(পরি)]

নিম্নের তথ্যাদির সাহায্যে ওয়েল্ডিং খরচ বের কর।

ব্যবহৃত বিদ্যুৎ	= ২৬০ অ্যাম্পিয়ার
ব্যবহৃত ভোল্টেজ	= ৩০ ভোল্ট
ওয়েল্ডিং গতি	= ২ মি/ঘন্টা
প্রয়োজনীয় ইলেকট্রোড	= ০.৪ কেজি/মি ওয়েল্ডিং
ইলেকট্রোড খরচ	= ১০০ টাকা/কেজি
শ্রম খরচ	= ১০ টাকা/ঘন্টা
বিদ্যুৎ খরচ	= ২ টাকা/কিলোওয়াট
মেশিনের দক্ষতা	= ০.৫০%
ইলেকট্রোডের ব্যাস	= ৬ মিমি
উপরি খরচ ইলেকট্রোডে খরচের ১০%	

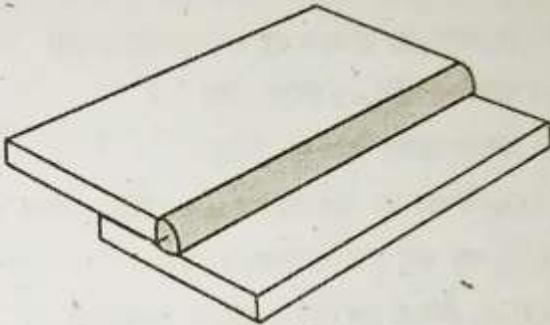

Estimate the material cost of

Butt welding job

উদাহরণ-৩। 10 মিমি পুরুত্ব প্লেট থেকে 2.5×1 মি ৭টি সিলিন্ড্রিক্যাল বয়লার ড্রাম তৈরি করতে হবে। উভয় প্রান্তের মুখ গোলাকৃত প্লেট দ্বারা ঢেকে সিলিন্ডারের ভিতর ও বাহিরে সিম ওয়েল্ডিং হবে। নিম্নের তথ্যাদির সাহায্যে ওয়েল্ডিং ব্যয় বের কর।

- ১। ওয়েল্ডিং গতি 3 মি/ঘন্টা (ভিতরে) 3.5 মি/ঘন্টা (বাহিরে)
- ২। ইলেকট্রোড প্রয়োজন = 1.5 মিটার/মিটার ওয়েল্ডিং
- ৩। ইলেকট্রোড খরচ = 2 টাকা/মিটার
- ৪। বিদ্যুৎ প্রয়োজন = 5 কিলোওয়াট/মিটার ওয়েল্ডিং
- ৫। বিদ্যুৎ খরচ = 1 টাকা/কিলোওয়াট
- ৬। শ্রম বাবদ খরচ = 10 টাকা/ঘন্টা
- ৭। উপরি খরচ = মুখ্য ব্যয় এর 100%
- ৮। স্থাপন ও ক্লাস্ট্রির বাবদ ওয়েল্ডিং সময়ের ৫%

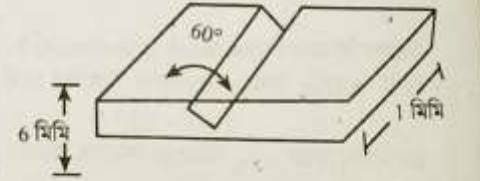

Estimate the material cost of

Pipe welding job.

উদাহরণ-৩। 10 মিমি পুরুত্ব প্লেট থেকে 2.5×1 মি ৭টি সিলিন্ড্রিক্যাল বয়লার ড্রাম তৈরি করতে হবে। উভয় প্রান্তের মুখ গোলাকৃত প্লেট দ্বারা ঢেকে সিলিন্ডারের ভিতর ও বাহিরে সিম ওয়েল্ডিং হবে। নিম্নের তথ্যাদির সাহায্যে ওয়েল্ডিং ব্যয় বের কর।

- ১। ওয়েল্ডিং গতি 3 মি/ঘন্টা (ভিতরে) 3.5 মি/ঘন্টা (বাহিরে)
- ২। ইলেকট্রোড প্রয়োজন = 1.5 মিটার/মিটার ওয়েল্ডিং
- ৩। ইলেকট্রোড খরচ = 2 টাকা/মিটার
- ৪। বিদ্যুৎ প্রয়োজন = 5 কিলোওয়াট/মিটার ওয়েল্ডিং
- ৫। বিদ্যুৎ খরচ = 1 টাকা/কিলোওয়াট
- ৬। শ্রম বাবদ খরচ = 10 টাকা/ঘন্টা
- ৭। উপরি খরচ = মুখ্য ব্যয় এর 100%
- ৮। স্থাপন ও ক্রান্তির বাবদ ওয়েল্ডিং সময়ের ৫%

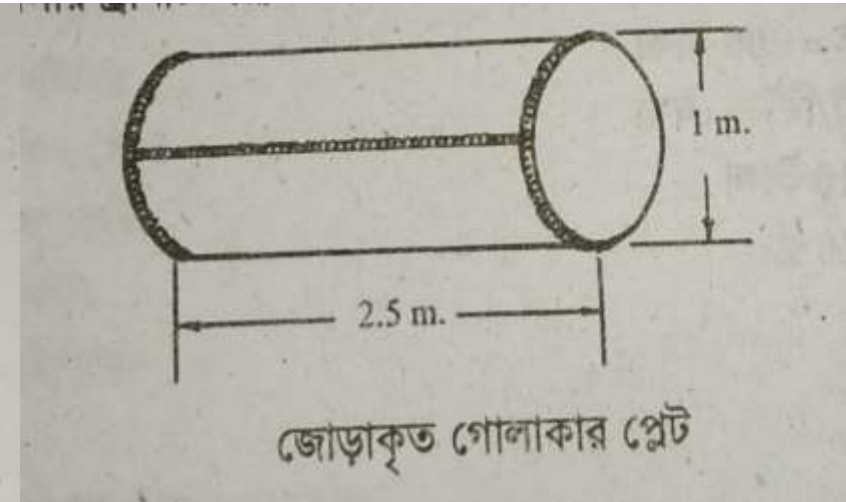

Estimate the labor cost

- To calculate the number, multiply the direct labor hourly rate by the number of direct labor hours required to complete one unit.
- For example, if the direct labor hourly rate is \$10 and it takes five hours to complete one unit, the direct labor cost per unit is \$10 multiplied by five hours, or \$50.

Estimate the overhead cost

Steps of overhead cost

- List the expense,
- Add the overhead cost,
- Calculate the overhead rate,
- Compare to sales,
- Compare the labor cost.

Estimate the total cost of the job

- List the expense
- Add the overhead cost
- Calculate the overhead rate
- Compare to sales
- Compare the labor cost

Any Questions?



*Thank
you*



Welcome

Prepared By:



Engr. Pabitra Kumar Halder

Chief Instructor & HoD (MT)

Barishal Polytechnic Institute

27052-Mechanical Estimating & Costing

Chapter : 10

Semester : 5th

Department : Mechanical

Course : Diploma-in- Engineering

UNDERSTAND THE METHODS OF ESTIMATION OF THE PATTERN SHOP AND WELDING SHOP JOB

Estimate the pattern cost of

1.Pully.

2.Flange ,

3.Bracket.

Estimate the pattern cost of pulley.

উদাহরণ-১৪। চিত্রে প্রদত্ত মাইল্ড স্টিল দিয়ে তৈরি জবটির মোট মেশিনিং বাবদ খরচ নির্ণয় কর। সকল প্রয়োজনীয় তথ্য আদর্শ মান ও বাজার মূল্য অনুযায়ী বিবেচনা কর। [বাকাশিবো-২০০৮]

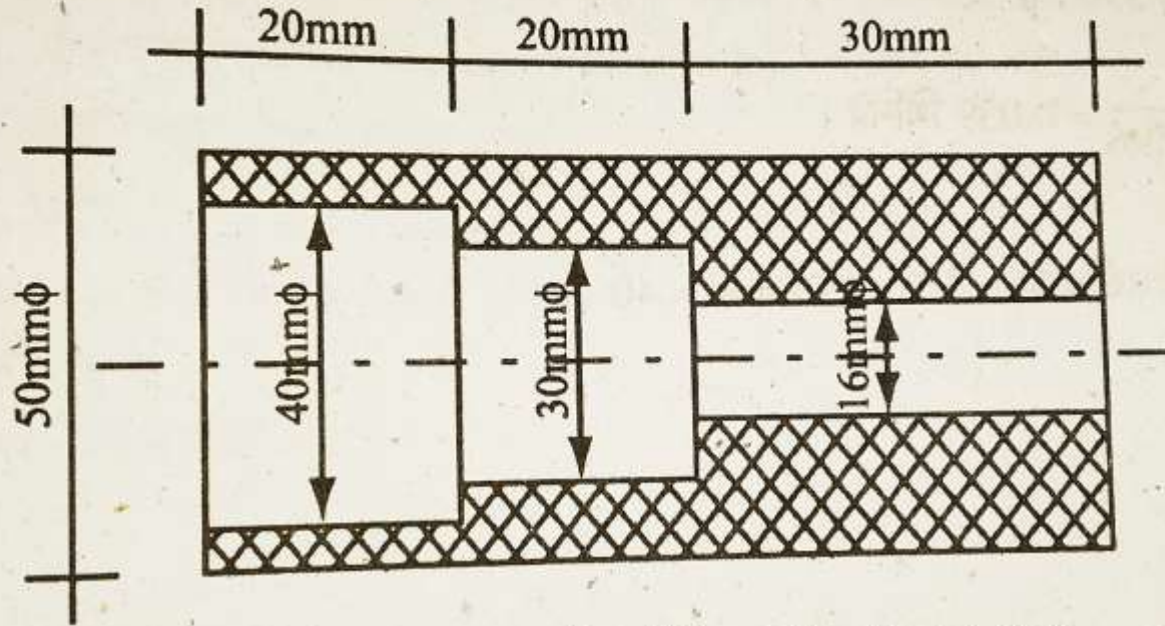

মোট মেশিনিং বাবদ খরচ নির্ণয় কর।

Estimate the pattern cost of flange

১০.১.৪ একটি ফ্লেঞ্জ-এর চিত্র অঙ্কন :

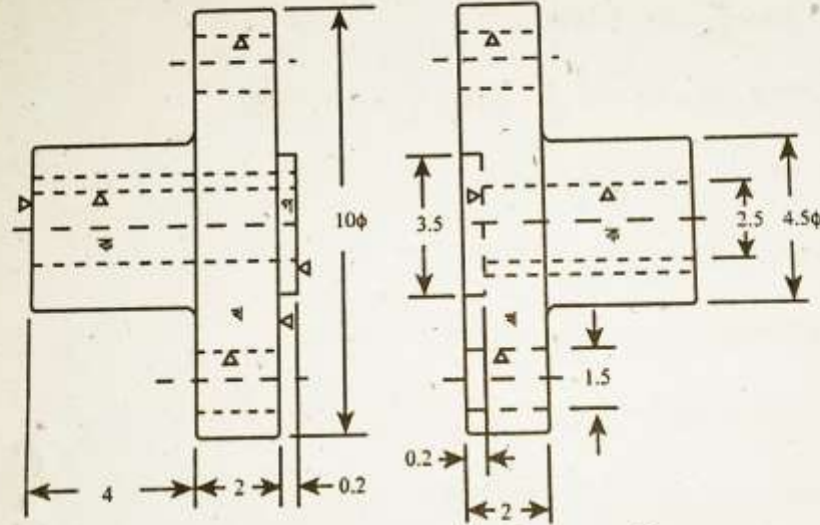

উপরোক্ত ফ্লেঞ্জ কাপলিংটি কাস্ট আয়রন দ্বারা প্রস্তুত করতে প্রাক্কলিত ব্যয় নিরূপণ কর। (প্যাটার্নটি প্রস্তুত বাবদ খরচও বিবেচনা করতে হবে) প্রতি ঘনমিটার গামারি কার্ভের মূল্য 13,500/00 টাকা। প্রতিজন শ্রমিকের দৈনিক মজুরি 80.00। প্যাটার্নটি তৈরি করতে একজন শ্রমিকের ৮ ঘণ্টা সময় লাগে। [সকল পরিমাপ সেমি]

Estimate the over head cost

calculate the overhead rate, divide the indirect costs by the direct costs and multiply by 100. If your overhead rate is 20%, it means the business spends 20% of its revenue on producing a good or providing services. A lower overhead rate indicates efficiency and more profits.

Estimate the total cost of the job

- The formula of average total cost is very simple and it is calculated by dividing the total cost of production by the number of goods produced.

Formula

The formula to calculate total cost is the following:

$TC \text{ (total cost)} = TFC \text{ (total fixed cost)} + TVC \text{ (total variable cost)}$

$\text{Average fixed cost} = \text{Total fixed cost} / \text{Quantity of units produced.}$

$\text{Average variable cost} = \text{Total variable cost} / \text{Quantity of units produced.}$



*Thank
you*



Welcome

Prepared By:



Engr. Pabitra Kumar Halder

Chief Instructor & HoD (MT)

Barishal Polytechnic Institute

27052-Mechanical Estimating & Costing

Chapter : 11

Semester : 5th

Department : Mechanical

Course : Diploma-in- Engineering

UNDERSTAND THE PROJECT PLANNING

Concept of project planning

Project planning is a discipline for stating how to complete a project within a certain timeframe, usually with defined stages, and with designated resources. One view of project planning divides the activity into: Setting objectives (these should be measurable) . Planning the schedule. Making supporting plans.

Steps of project planning

- Create and Analyze Business Case.
- Identify and Meet Stakeholders for Approval.
- Define Project Scope.
- Set Goals and Objectives.
- Determine Deliverables.
- Create Project Schedule and Milestones.
- Assignment of Tasks.
- Carry Out Risk Assessment.

Analysis of break-even point

- The break-even analysis lets you determine what you need to sell, monthly or annually, to cover your costs of doing business—your break-even point. The break-even analysis table calculates a break-even point based on fixed costs, variable costs per unit of sales, and revenue per unit of sales.

Diagram of break-even point

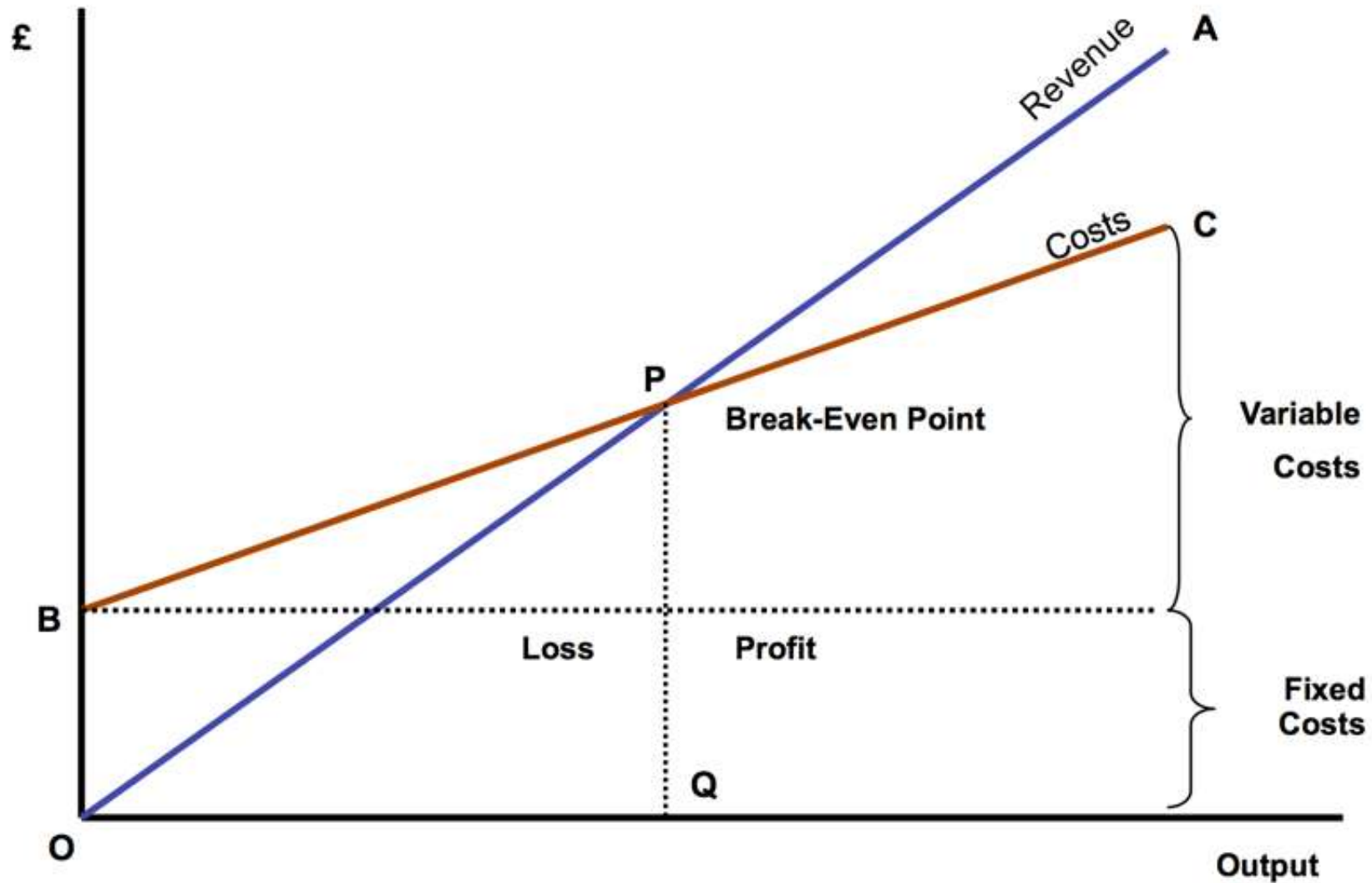



*Thank
you*



Welcome

Prepared By:



Engr. Pabitra Kumar Halder

Chief Instructor & HoD (MT)

Barishal Polytechnic Institute

27052-Mechanical Estimating & Costing

Chapter : 12

Semester : 5th

Department : Mechanical

Course : Diploma-in- Engineering

UNDERSTAND THE MATERIAL COST ECONOMY

Define material cost economy

Material cost is the cost of materials used to manufacture a product or provide a service. Excluded from the material cost is all indirect materials, such as cleaning supplies used in the production process . Add the standard amount of scrap associated with manufacturing one unit.

Explain the role of material cost

1. materials(net amount),
2. Standard materials,
3. Update materials handling,
4. Inspection and inventory,
5. Materials indirect cost,
6. Uses of materials,
7. Assembly product and parts,

Steps of materials cost economy

1. Substitute Lower Cost Materials Where Possible
2. Reduce Waste
3. Eliminate Unnecessary Product Features
4. Negotiate, Negotiate, Negotiate
5. Buy Need, Not Potential
6. Transform Buyers Into Suppliers
7. Provide Warehouse and Distribution Services
8. Offer Quick Payment for Lower Prices

Estimate the selling price of a cast iron gear.

The following steps should follow to estimate the selling price of cast iron.

1. Check purchasing practice,
2. Value analysis,
3. Standardize materials,
4. update-old ideas,
5. Analyze cost and usage,
6. Analyze profit quality.



Fig: cast iron gear



*Thank
you*

